

## Project Report Appendices

The following section contains the appendices as listed in the Delaware Valley 2015 LiDAR Project Report.

## Appendix A

# GPS/IMU Processing Statistics Flight Logs Base Station Logs

There were twenty-one total lifts. Graph reports generated from processing software are found on the following pages.

Apr 12, 2015-A (N22GE, SN8239) .....	2	Apr 22, 2015-B (N269JE, SN7234) .....	149
Flight Log.....	8	Flight Log.....	155
Base Station Log.....	10	Base Station Log.....	159
Apr 12, 2015-B (N22GE, SN8239) .....	12	Apr 24, 2015-A (N269JE, SN7234) CrossKeys	
Flight Log.....	18	and KWAY.....	161
Base Station Log.....	20	Flight Log.....	167
Apr 13, 2015-A (N22GE, SN8239) .....	22	Base Station Log.....	171
Flight Log.....	28	Apr 25, 2015-A (N269JE, SN7234) .....	173
Base Station Log.....	30	Flight Log.....	179
Apr 14, 2015-A (N22GE, SN8239) .....	32	Base Station Log.....	183
Flight Log.....	37	May 23, 2015-A (N22GE, SN8239) .....	185
Base Station Log.....	39	Flight Log.....	191
Apr 14, 2015-B (N22GE, SN8239) .....	41	Nov 25, 2015-A (N22GE, SN7178).....	193
Flight Log.....	47	Flight Log.....	199
Base Station Log.....	49	Base Station Log.....	201
Apr 16, 2015-A (N22GE, SN8239) .....	51		
Flight Log.....	57		
Base Station Log.....	59		
Apr 16, 2015-B (N22GE, SN8239) .....	61		
Flight Log.....	67		
Apr 18, 2015-A (N262AS, SN7178).....	70		
Flight Log.....	75		
Apr 18, 2015-A (N22GE, SN8239) .....	77		
Flight Log.....	83		
Base Station Log.....	86		
Apr 19, 2015-A (N262AS, SN7178).....	88		
Flight Log.....	94		
Apr 19, 2015-B (N262AS, SN7178).....	96		
Flight Log.....	101		
Base Station Log.....	104		
Apr 19, 2015-A (N269JE, SN7234) .....	106		
Flight Log.....	112		
Base Station Log.....	116		
Apr 19, 2015-A (N22GE, SN8239) .....	118		
Flight Log.....	124		
Base Station Log.....	126		
Apr 19, 2015-B (N22GE, SN8239) .....	128		
Flight Log.....	134		
Apr 22, 2015-A (N269JE, SN7234) .....	137		
Flight Log.....	143		
Base Station Log.....	147		

# Apr 12, 2015-A (N22GE, SN8239)

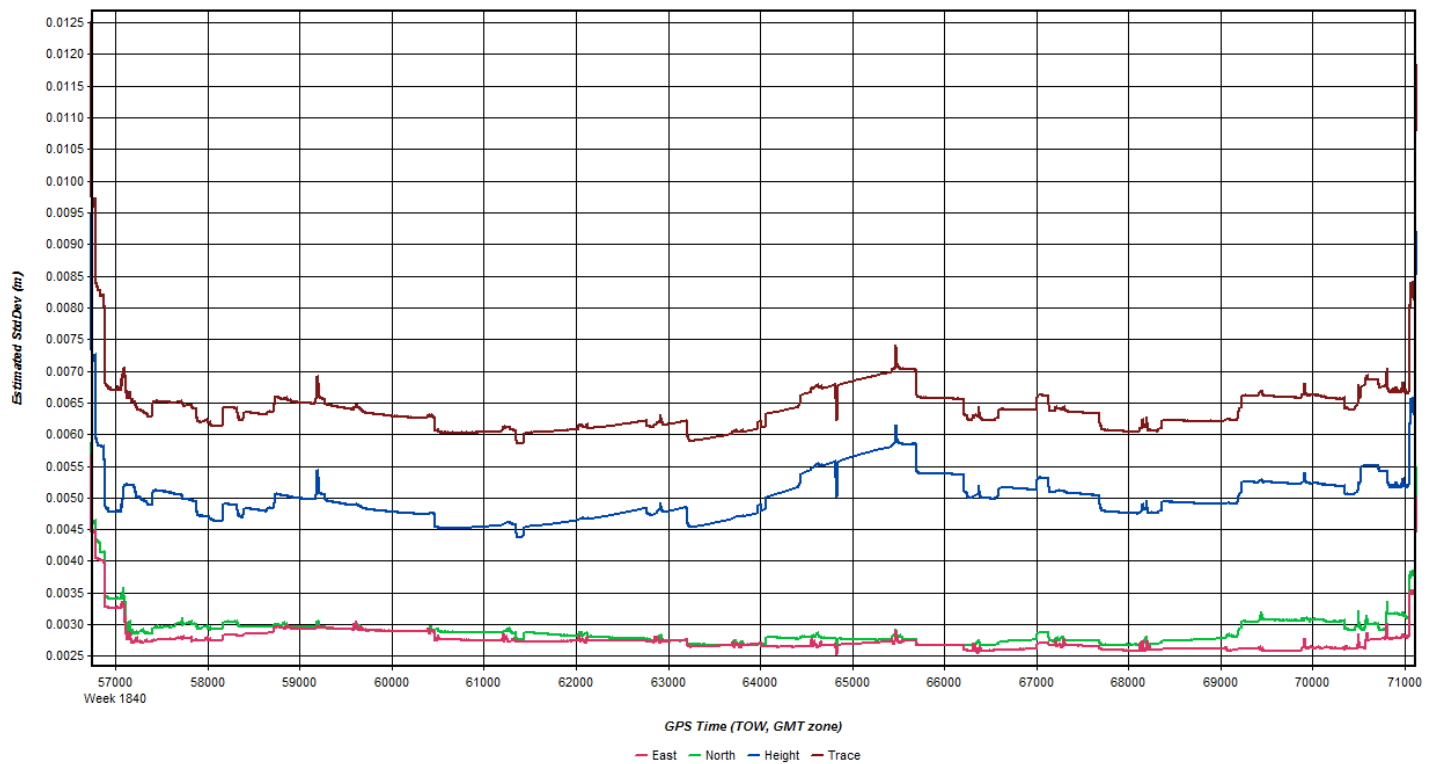
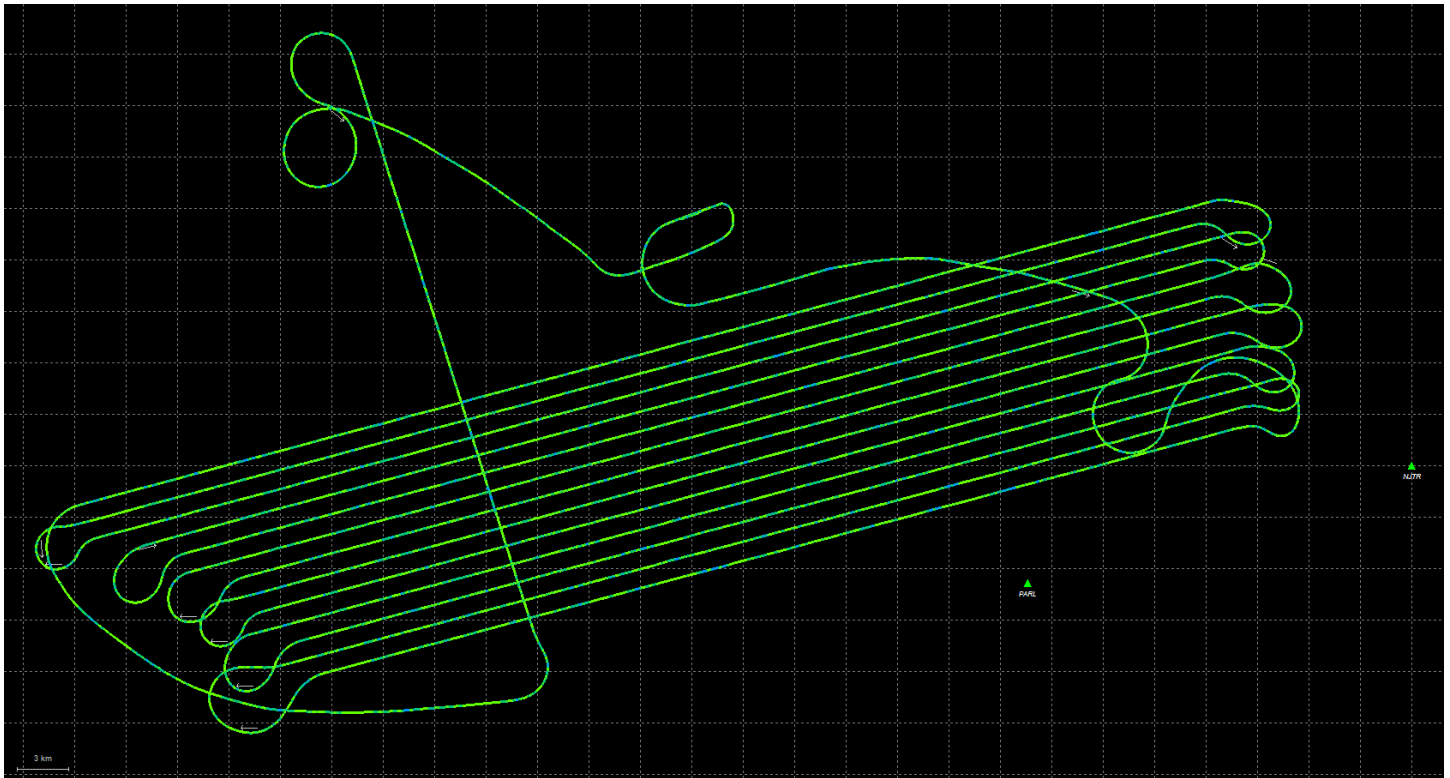

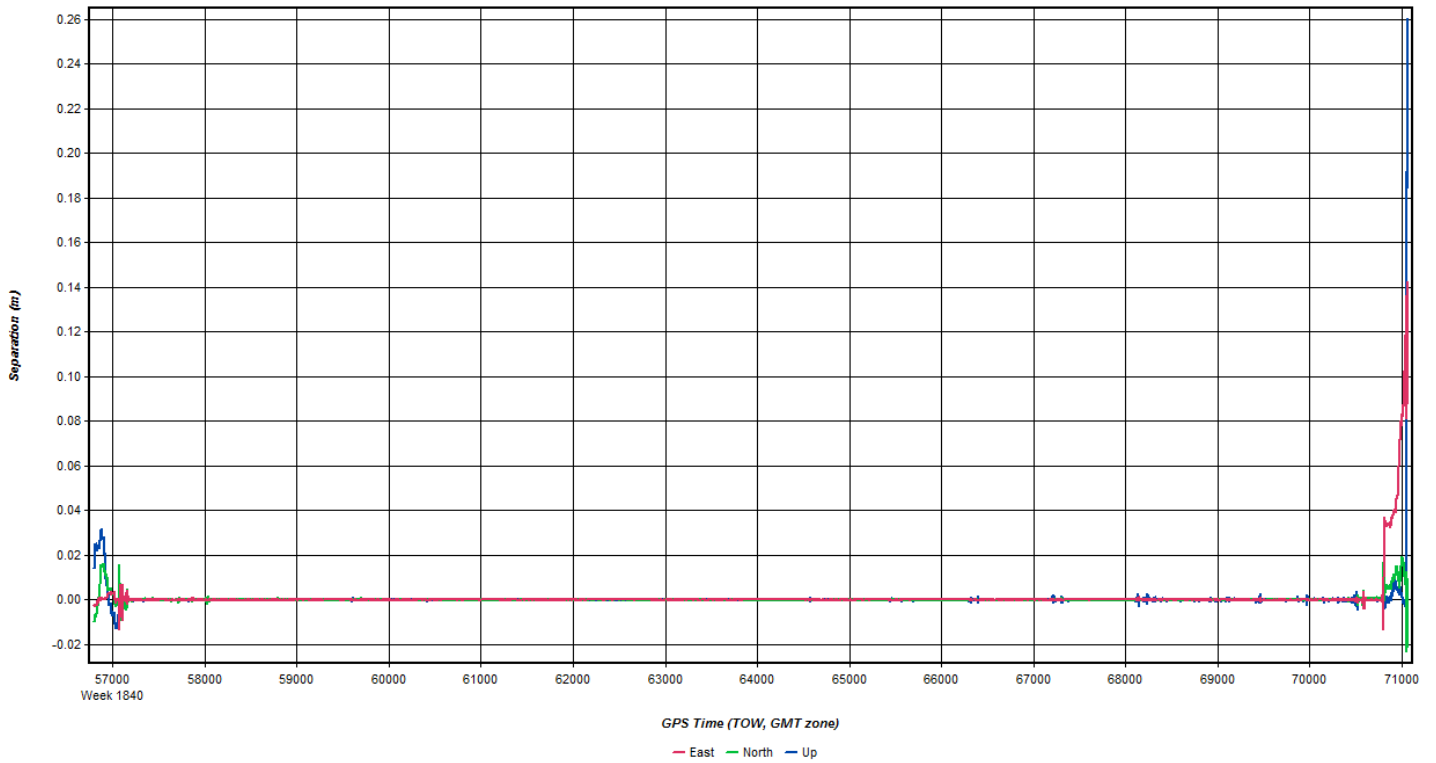
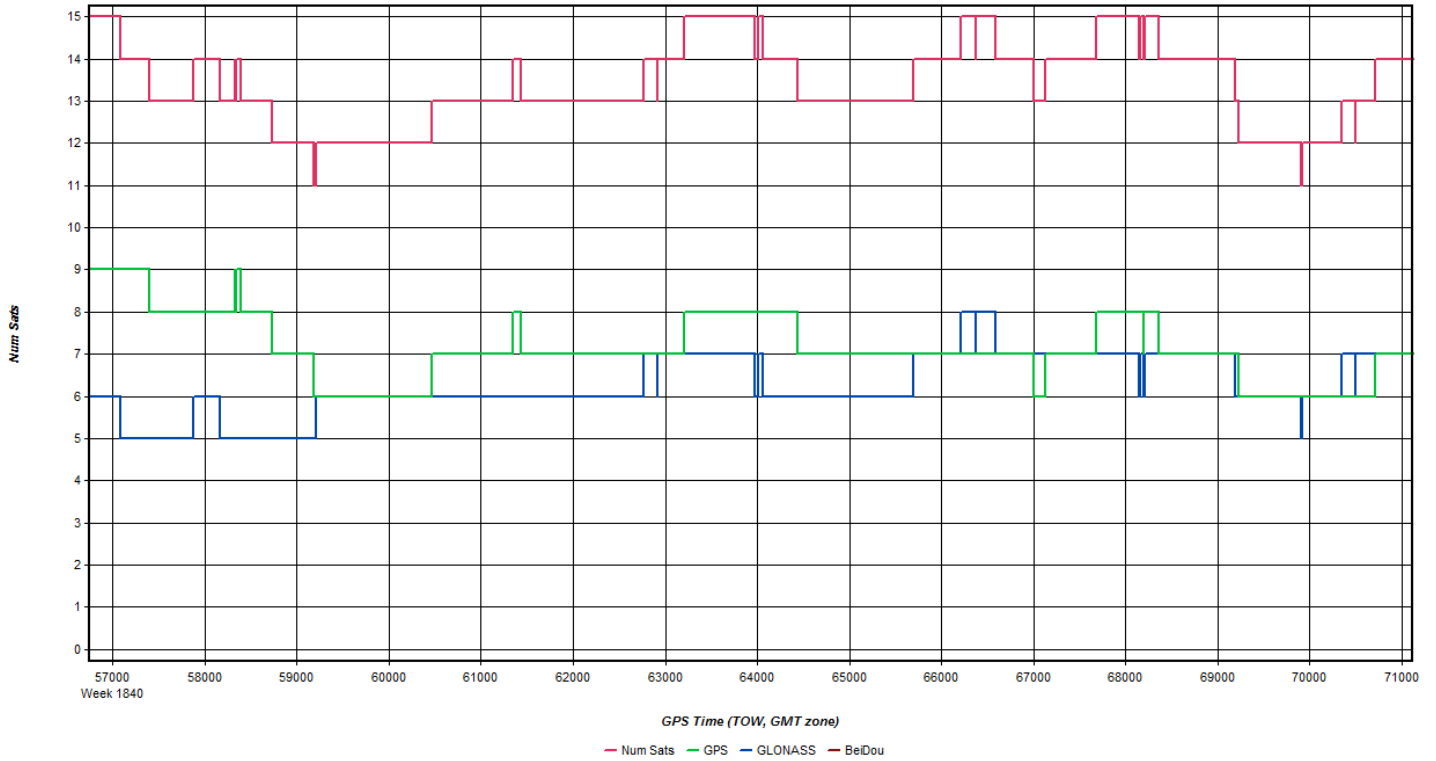

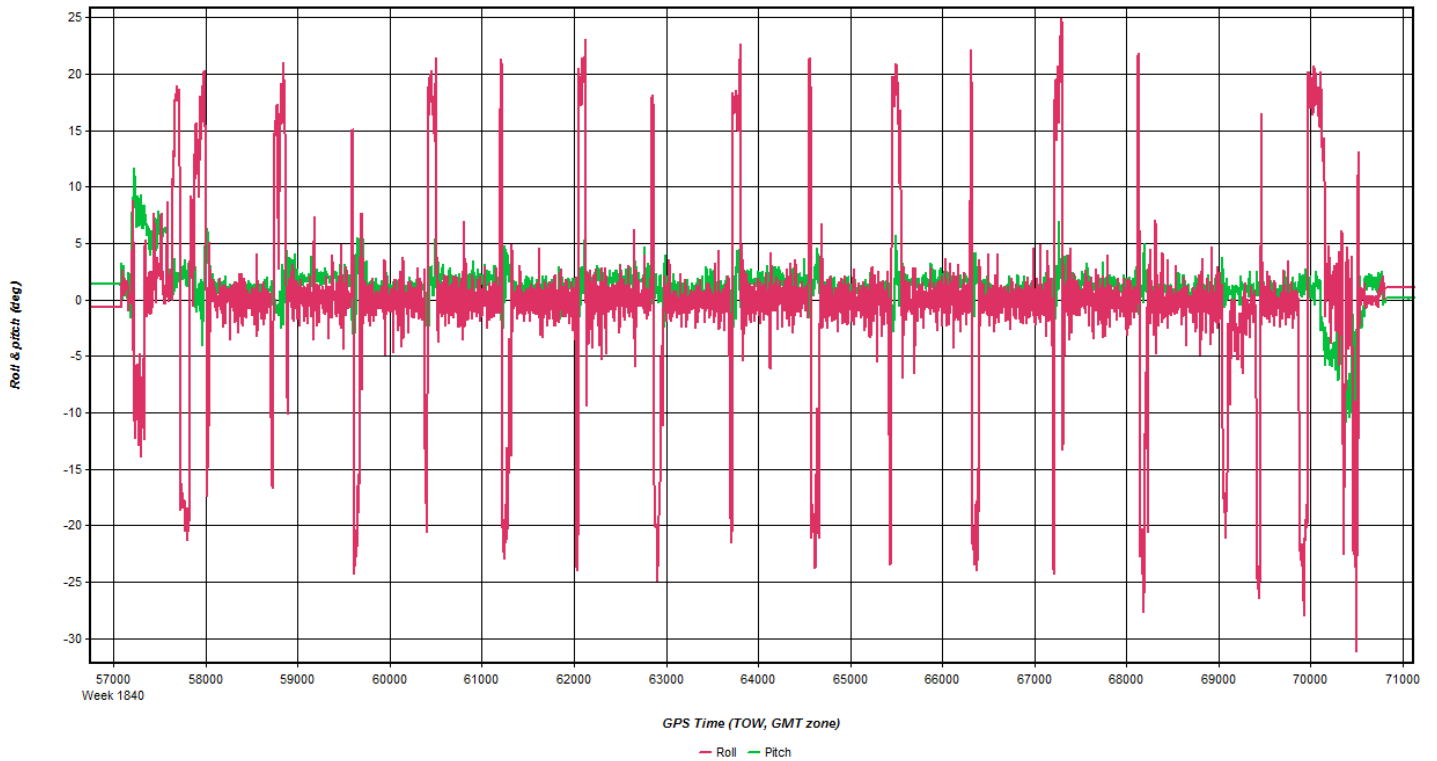
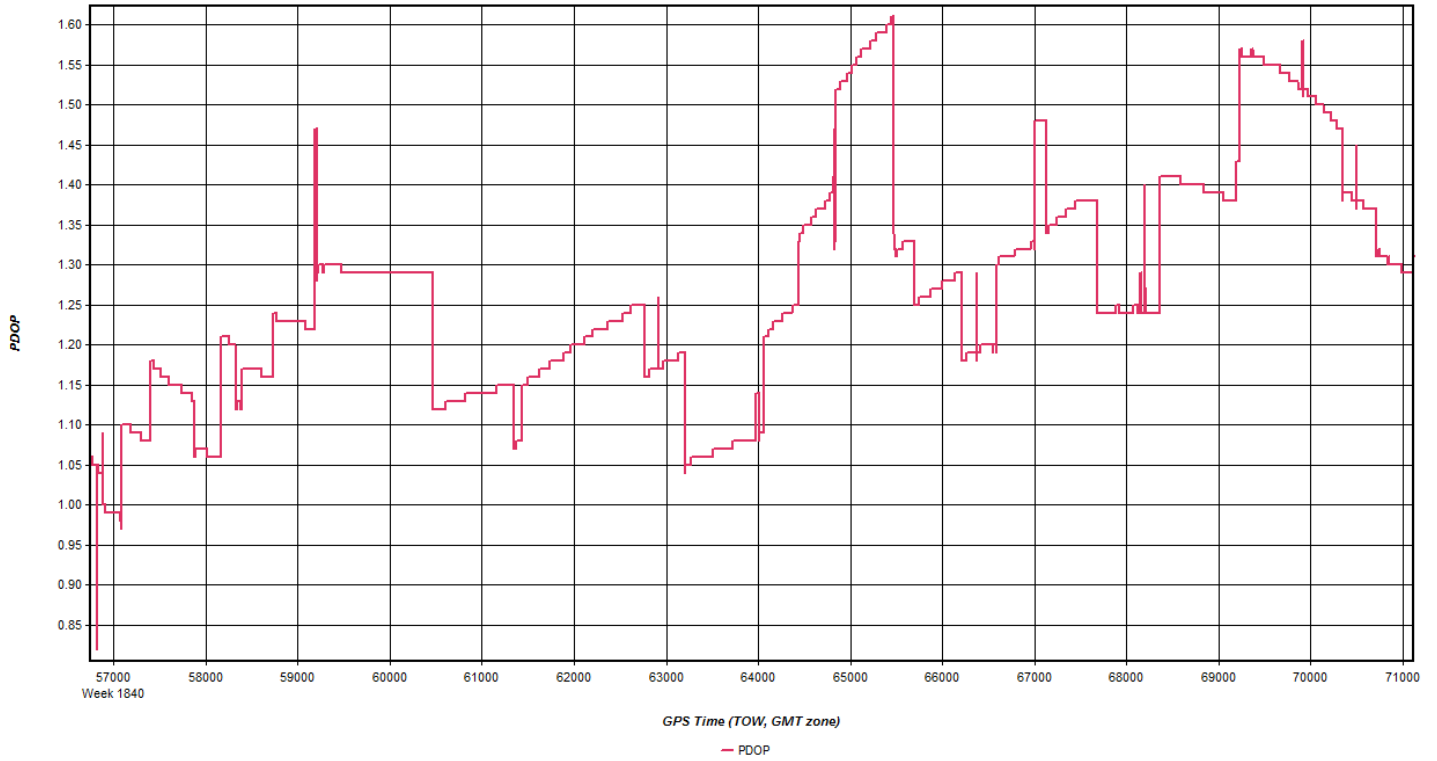

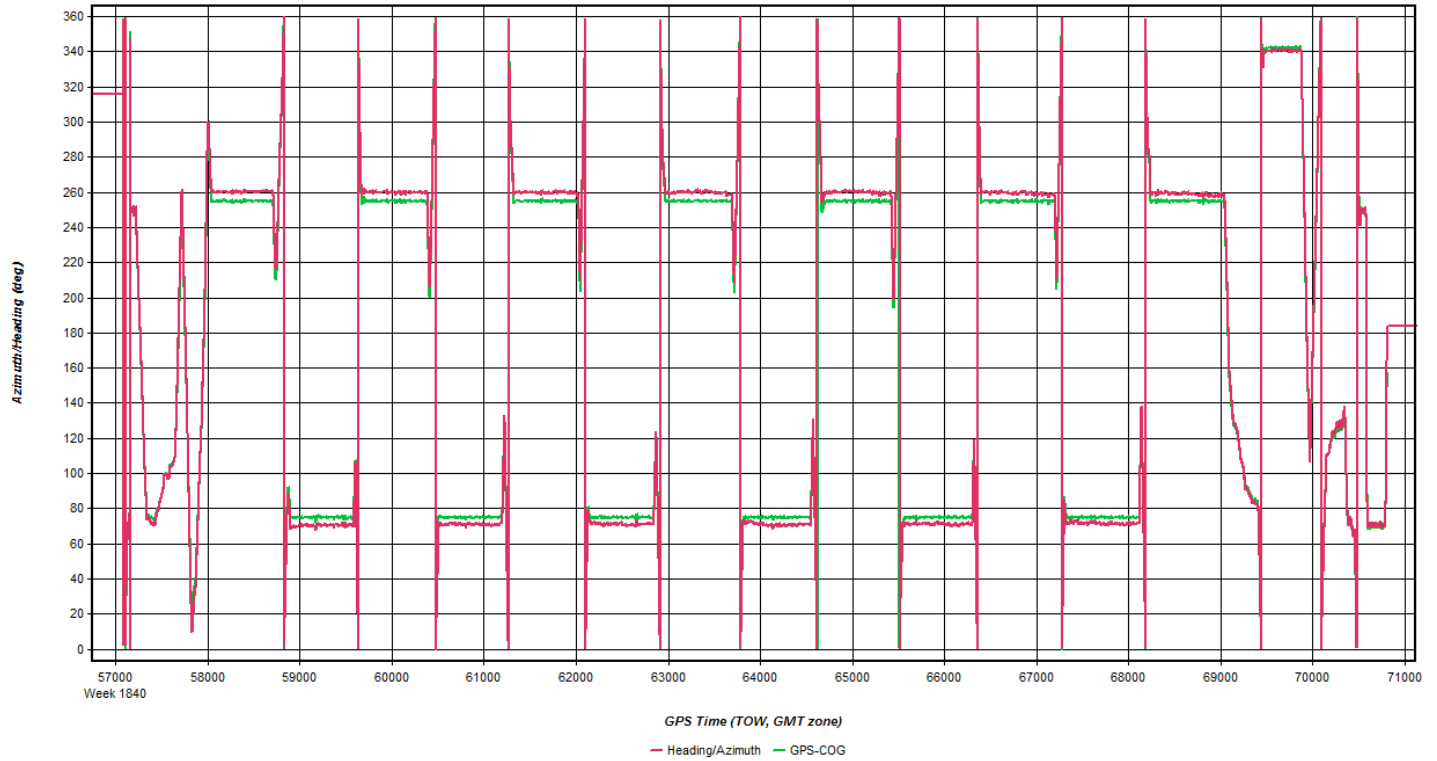

**Coordinate/Antenna Settings**

Master Remote

Base Station  
 1: NJTR Name: NJTR  Disabled  
 File: D:\Proc\26236\_DVRPC\8303\20150412\_154338\njtr1020.gpb

Coordinates  
 Latitude: North 40 15 27.46254   
 Longitude: West 74 47 48.07181   
 Ellipsoidal height: 41.271 m   
 Datum: NAD83(2011)

Antenna Height  
 From station file: LEIAR10, NONE   
 Antenna profile: LEIAR10   
 Measured height: 0.000 m  
 ARP to L1 offset: 0.089 m  
 Applied height: 0.089 m  
 Measured to:  
 ARP  
 L1 Phase Centre



Coordinate/Antenna Settings

Master Remote

Base Station  
2: PARL Name: PARL  Disabled  
File: D:\Proc\26236\_DVRPC\8303\20150412\_154338\par1020.gpb

Coordinates  
Latitude: North 40 11 46.22401   
Longitude: West 75 03 35.66418   
Ellipsoidal height: 76.548 m   
Datum: NAD83(2011)

Antenna Height  
From station file: TRM57971.00, NONE   
Antenna profile: TRM57971.00   
Measured height: 0.000 m  
ARP to L1 offset: 0.067 m  
Applied height: 0.067 m  
Measured to:  
 ARP  
 L1 Phase Centre

OK Cancel

# Flight Log

8228.1 → 8231.8

**OPERATORS FLIGHT LOG**

MISSION: S		YYYYMMDD_TIME(GPS)		OPERATOR:		DATE:		LEICA ALS-70		
PROJECT NUMBER		LINE NO. & Hdg		GND SPEED (KTS)		FREQ Hz		AIRCRAFT: N226E		
PROJECT NUMBER		LINE NO. & Hdg		GND SPEED (KTS)		FREQ Hz		AIRCRAFT: N226E		
PROJECT NUMBER	LINE NO. & Hdg	GND SPEED (KTS)	FREQ Hz	SCAN ANGLE	PRF KHZ	FIXED GAIN	ALT (m)	TIME START	TIME STOP	REMARKS
26236								15:45	15:50	Static Start
								15:53		T/O
	1040	268	52	40	352	N/A	7.4K	16:07	16:18	Figure 8 @ 16:00z
	1039	87						16:21	16:32	
	1038	268					7.5K	16:34	16:46	needs reflight
	1037	87						16:48	16:59	
	1036	268						17:02	17:13	
	1035	87						17:15	17:27	
	1034	268						17:29	17:41	
	1033	87						17:43	17:55	
	1032	268						17:58	18:10	
	1031	87						18:12	18:24	
	1030	268						18:26	18:39	
	1029	87					7.4K	18:41	18:55	
	1028	268						18:57	19:10	
	1040	355						19:17	19:24	Figure 8 @ 19:24
								19:35		LAND
								19:40	19:45	Static Stop
STATUS	TOTAL LINES	FLOWN	LEFT	SITE	AIRCRAFT FERRY	STATIC	START	STOP	NOTES:	
○ 26236	42	14	29	3.3	.4	✓	15:45	19:45		
○						WX				
○										

AERO-METRIC, INC. N.6216 Resource Drive Sheboygan Falls, WI. 53085 PHONE: 920-467-2655 FAX: 888-253-6695 E-Mail: amepphoto@aerometric.com

# Base Station Log

### GPS OBSERVATION LOG

Station ID	ROXBORO KV5970	Date	4/12/2015
Project Number	<del>25481</del> 26236	Julian Date	<del>1721/2015</del>
Project Name	HELIDAR USGS DVRPL	Start Time	7:43 AM
Revr. Type	TRIMBLE R8 Navatel DL-V3	Stop Time	7:32 AM
Revr. S/N	<del>5329440824</del> NBV1213007	Rcvr. File Name	<del>08240210</del>
Antenna Type	Navatel 702-66	Observer	ZEKE INGRAM Dae Rolfes
Antenna S/N	NAE12110034		

New or Existing  
 Mon. New  
 Existing  
 Photo Taken:  
 Yes No  
 Monument Type:  
 Spike PK Nail  
 AM Washer  
 Other NAIL SET

Height Readings:  
 (Top of Monument to Bottom of Ground Plane)

Start	2.0	M.	Ft.
Stop	2.0	M.	Ft.
Mean	2.0	M.	Ft.

Monument Sketch and Notes:

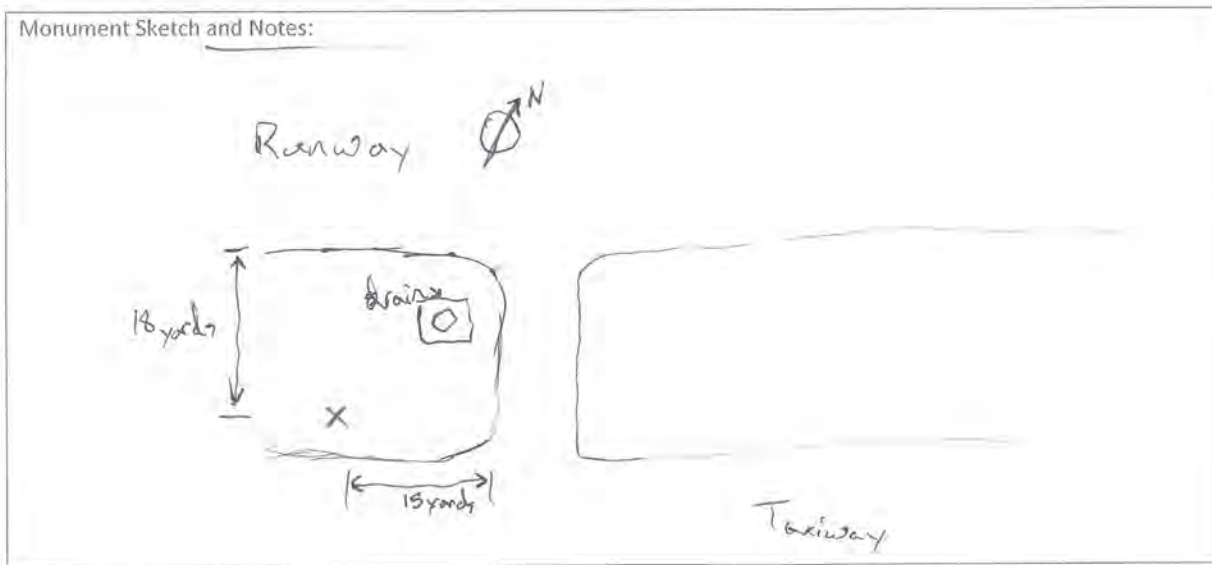

**Apr 12, 2015-B  
(N22GE, SN8239)**

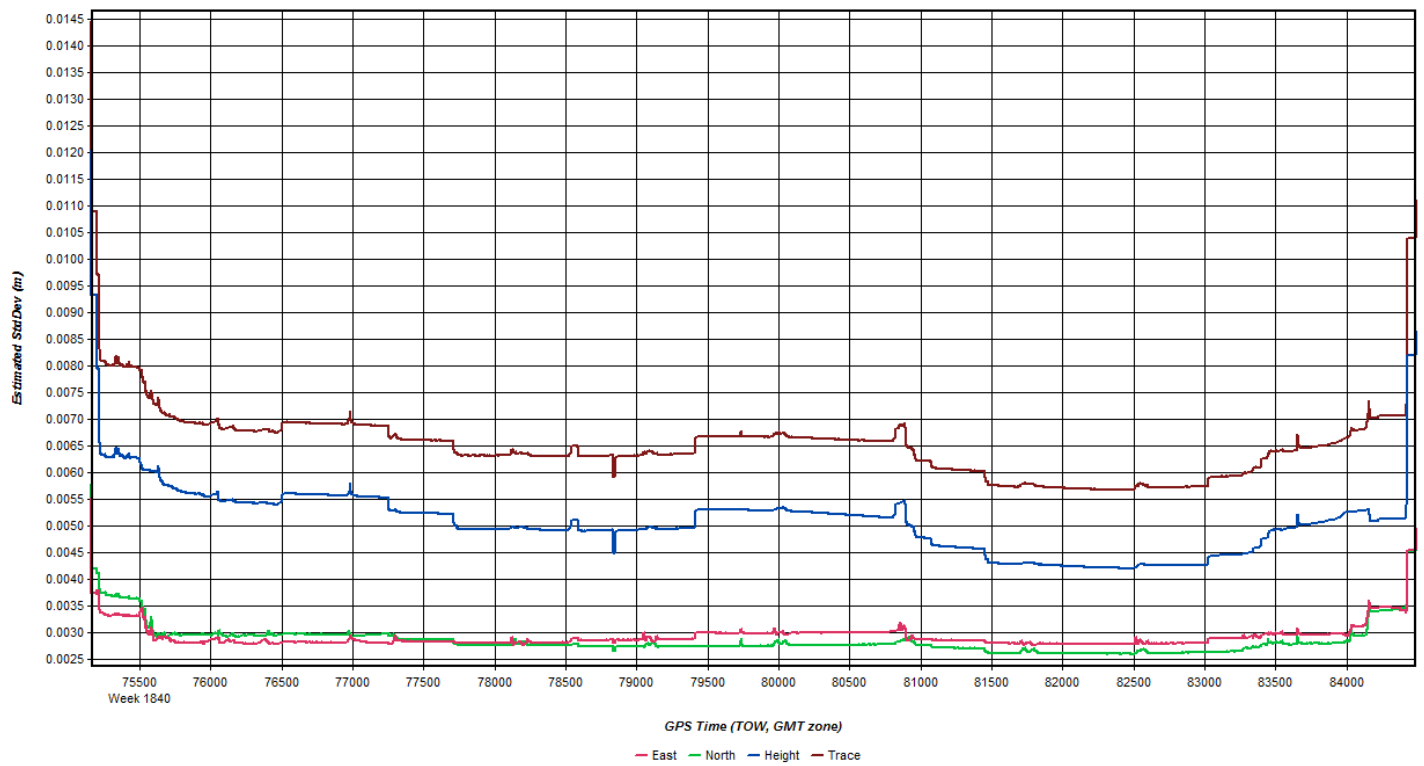
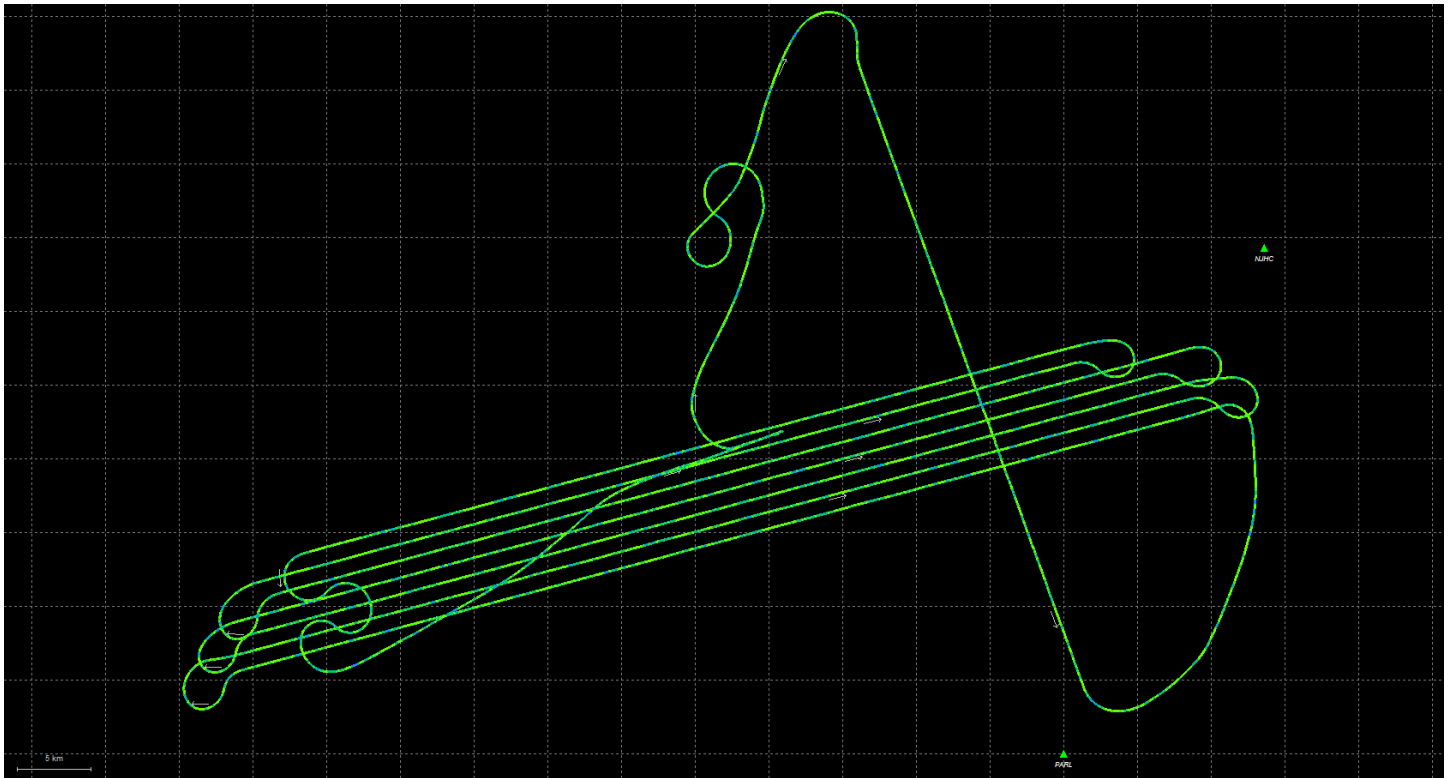

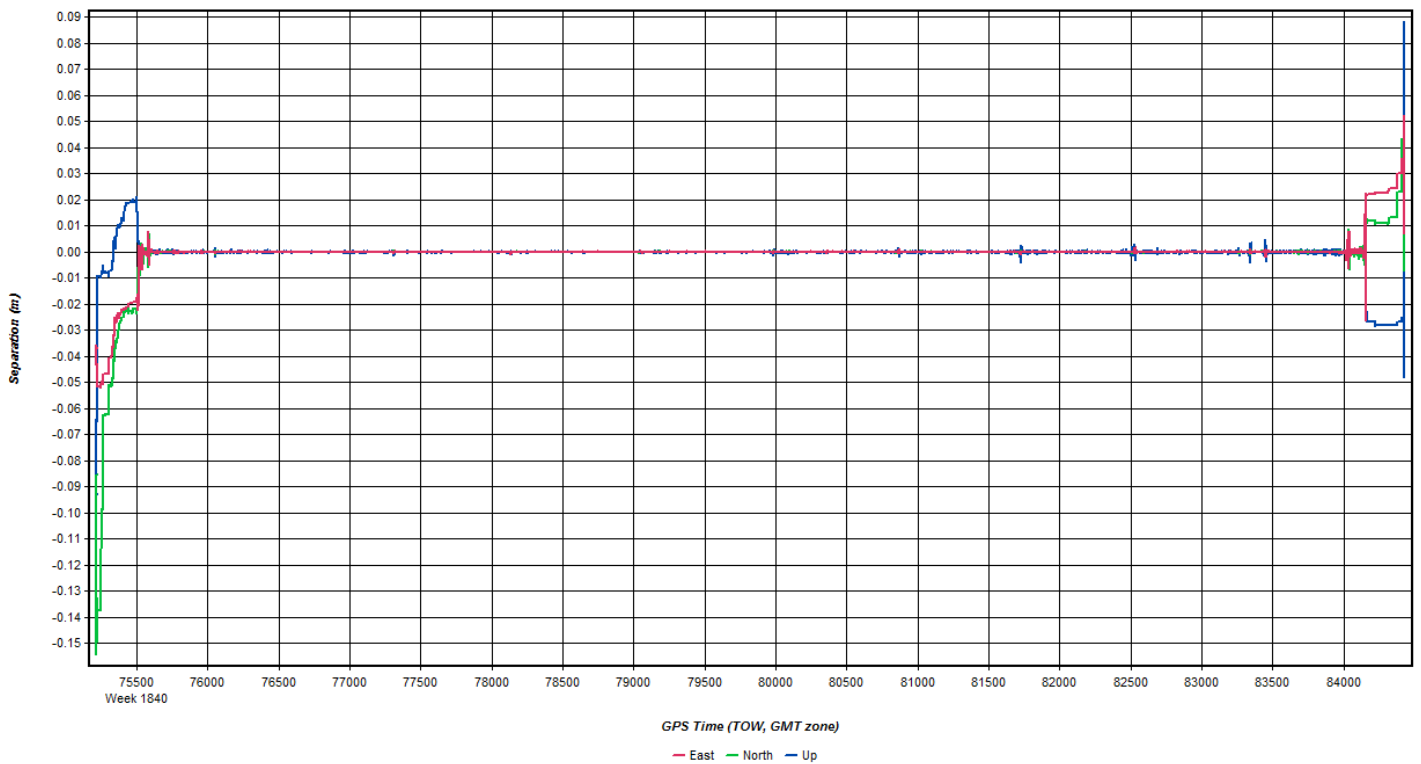
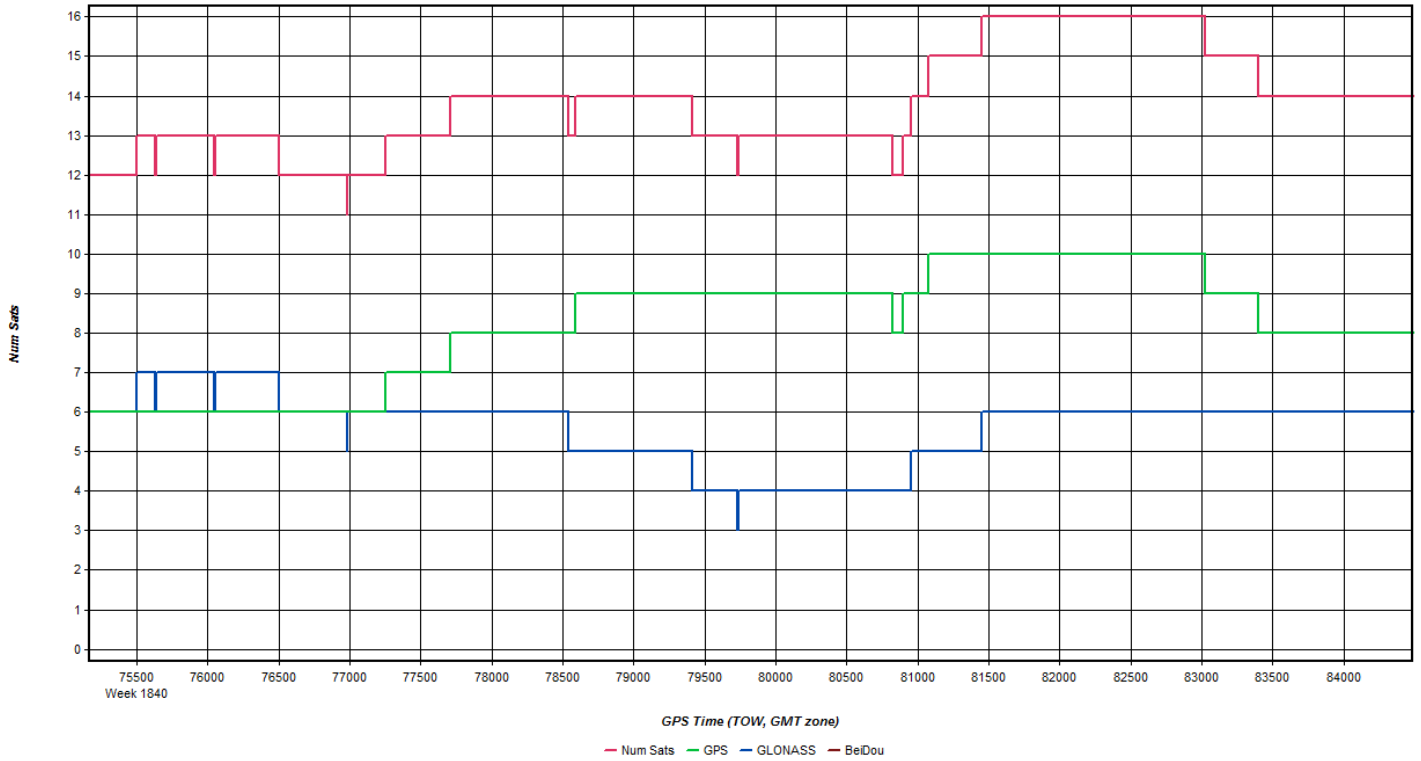



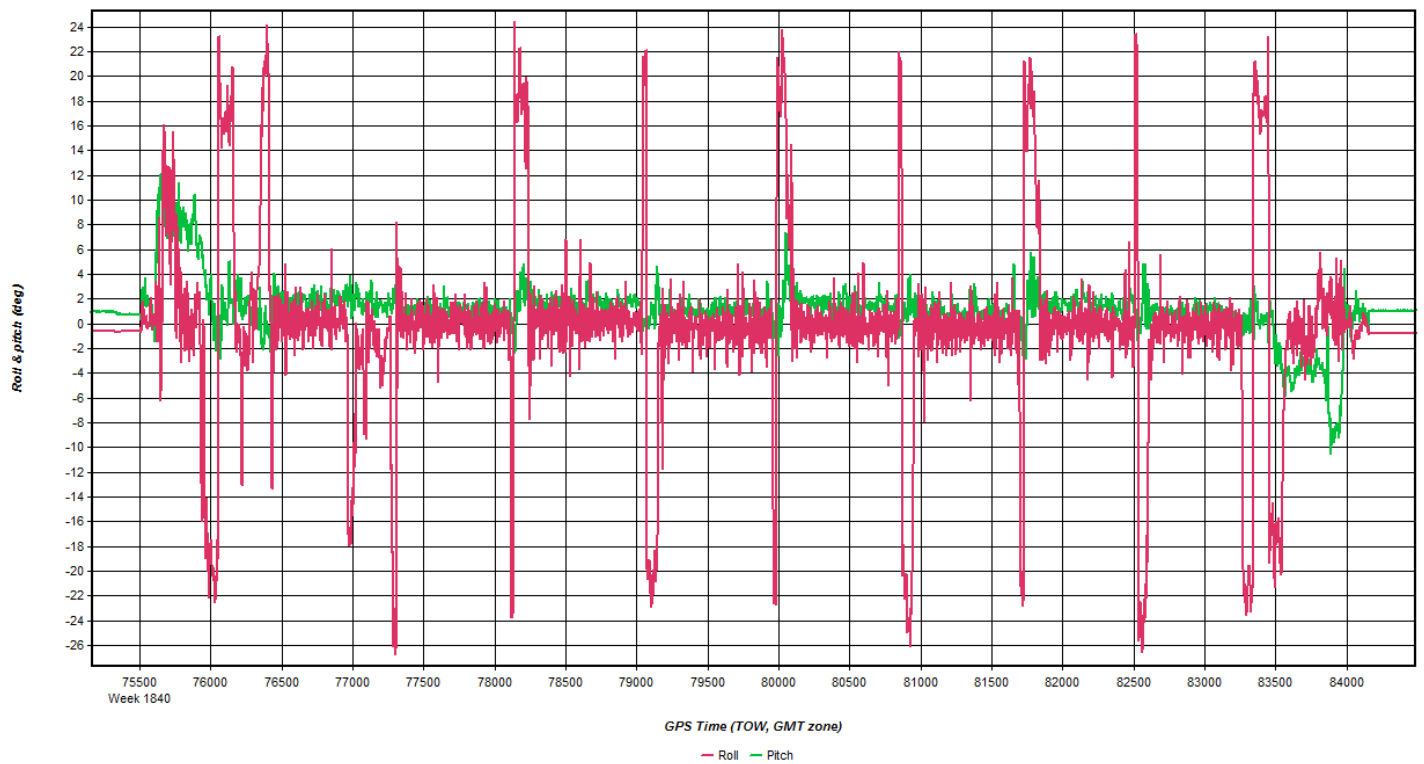

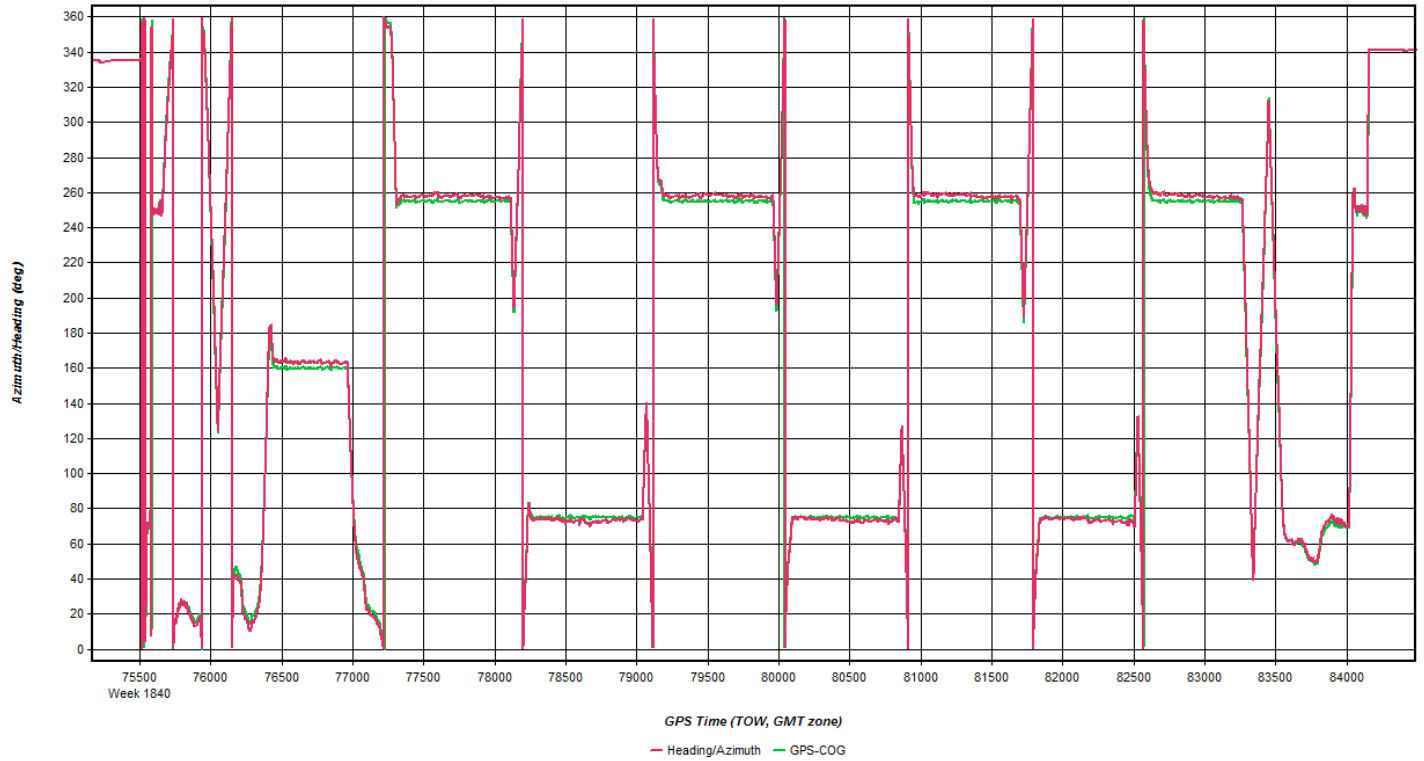

**Coordinate/Antenna Settings**

Master Remote

Base Station  
 2: NJHC Name: NJHC  Disabled  
 File: D:\Proc\26236\_DVRPC\RHD2\20150412\_205046\vnjhc1020.gpb

Coordinates  
 Latitude: North 40 30 05.80472   
 Longitude: West 74 54 04.01548   
 Ellipsoidal height: 95.918 m   
 Datum: NAD83(2011)

Antenna Height  
 From station file: LEIAT504GG, LEIS   
 Antenna profile: LEIAT504GG, LEIS   
 Measured height: 0.000 m  
 ARP to L1 offset: 0.087 m  
 Applied height: 0.087 m  
 Measured to:  
 ARP  
 L1 Phase Centre

Coordinate/Antenna Settings

Master Remote

Base Station  
1: PARL Name: PARL  Disabled  
File: D:\Proc\26236\_DVRPC\RHD2\20150412\_205046\parl1020.gpb

Coordinates  
Latitude: North 40 11 46.22401   
Longitude: West 75 03 35.66418   
Ellipsoidal height: 76.548 m   
Datum: NAD83(2011)

Antenna Height  
From station file: TRM57971.00, NONE   
Antenna profile: TRM57971.00   
Measured height: 0.000 m  
ARP to L1 offset: 0.067 m  
Applied height: 0.067 m  
Measured to:  
 ARP  
 L1 Phase Centre

# Flight Log

Scanned by CamScanner

8231.8 → 8234.2

**OPERATORS FLIGHT LOG**

MISSION: S		V563 DVRPL		DATE: 4/12/15		LEICA ALS-70		
PILOT: Yoma		OPERATOR: Rofcus		AIRCRAFT: N226E		MNR70 DRIVE		
LINE NO. & Hdg	GND.SPEED (KTS)	FREQ Hz	SCAN ANGLE	PRF KHz	FIXED GAIN	ALT (m)	TIME START STOP	REMARKS
26236							20:53 20:58	Static Start
							21:00	T/O
1041 172	164	52	40	352	N/A	7.6k	21:13 21:22	Figure 8 @ 21:05
1027 265	161					7.5k	21:23 21:41	
1026 87	164						21:44 21:57	
1025 265	165						21:59 22:12	
1024 87	163						22:15 22:27	
1023 265	168						22:30 22:41	
1022 87	164						22:44 22:54	
1021 268	166						22:57 23:07	Figure 8 @ 23:07
							23:14	Low
							23:22 23:27	Static Stop
<b>STATUS</b>		<b>TOTAL LINES</b>		<b>AIRCRAFT</b>		<b>NOTES:</b>		
○	26236	FLOWN	LEFT	SITE	FERRY	STATIC	START STOP	
○				1.9	.5	✓	20:53	
○						W/K		

AERO-METRIC, INC. N.6216 Resource Drive Sheboygan Falls, WI. 53085 PHONE: 920-467-2655 FAX: 888-253-6695 E-Mail: amphoto@aerometric.com

# Base Station Log

### GPS OBSERVATION LOG

4/12/2015

Station ID	ROXBORO KV5970	Date	<del>4/12/2015</del>
Project Number	<del>25481</del> 26236	Julian Date	7 <del>43</del> 102
Project Name	LiDAR USGS DVRPL	Start Time	7:43 AM
Revr. Type	PRIMBLE R-8 Navatel DLVS	Stop Time	7:52 AM
Revr. S/N	<del>5329440824</del> NDU1213007	Revr. File Name	<del>08240234</del>
Antenna Type	Navatel 702-66	Observer	JEFF HOFFMAN Dan Hoffes
Antenna S/N	NAE12110034		

New or Existing  
 New  
 Existing  
 Photo Taken  
 Yes  No  
 Monument Type  
 Spike  PK Nail  
 AM Washer  
 Other **NAE SET**

Height Readings:  
 (Top of Monument to Bottom of Ground Plane)

Start	2.0	M.	Ft.
Stop	2.0	M.	Ft.
Mean	2.0	M.	Ft.

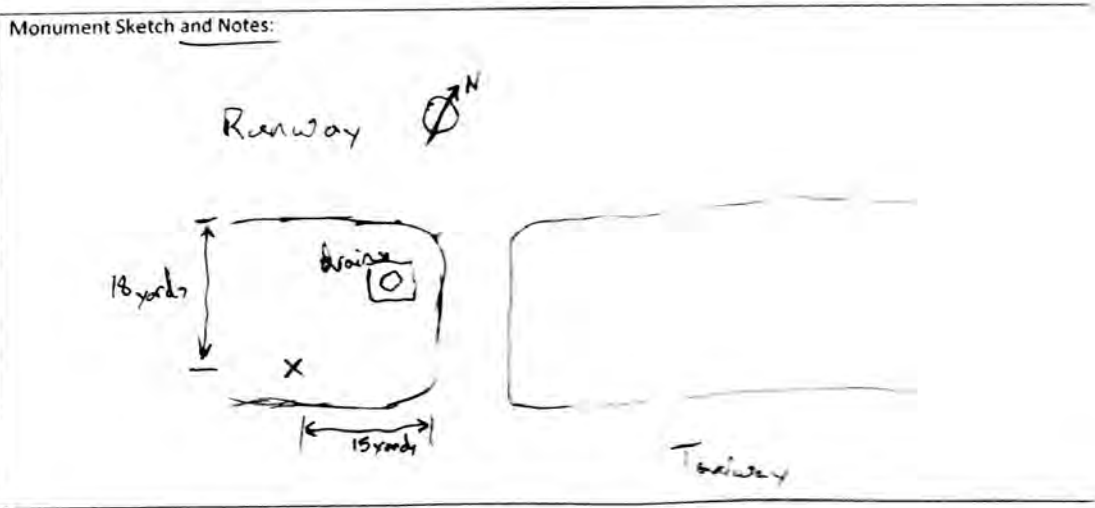

Scanned by CamScanner

**Apr 13, 2015-A  
(N22GE, SN8239)**



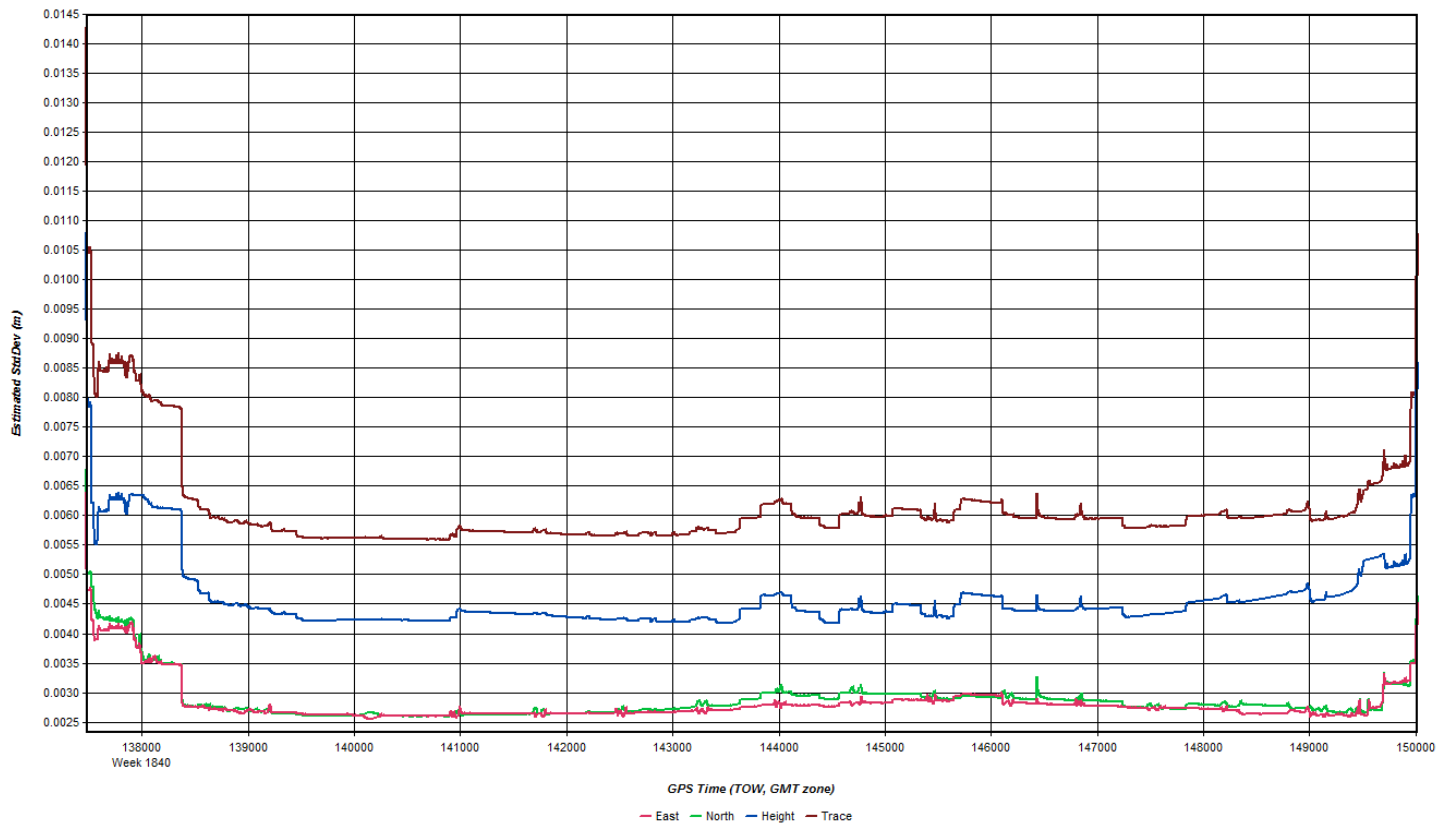
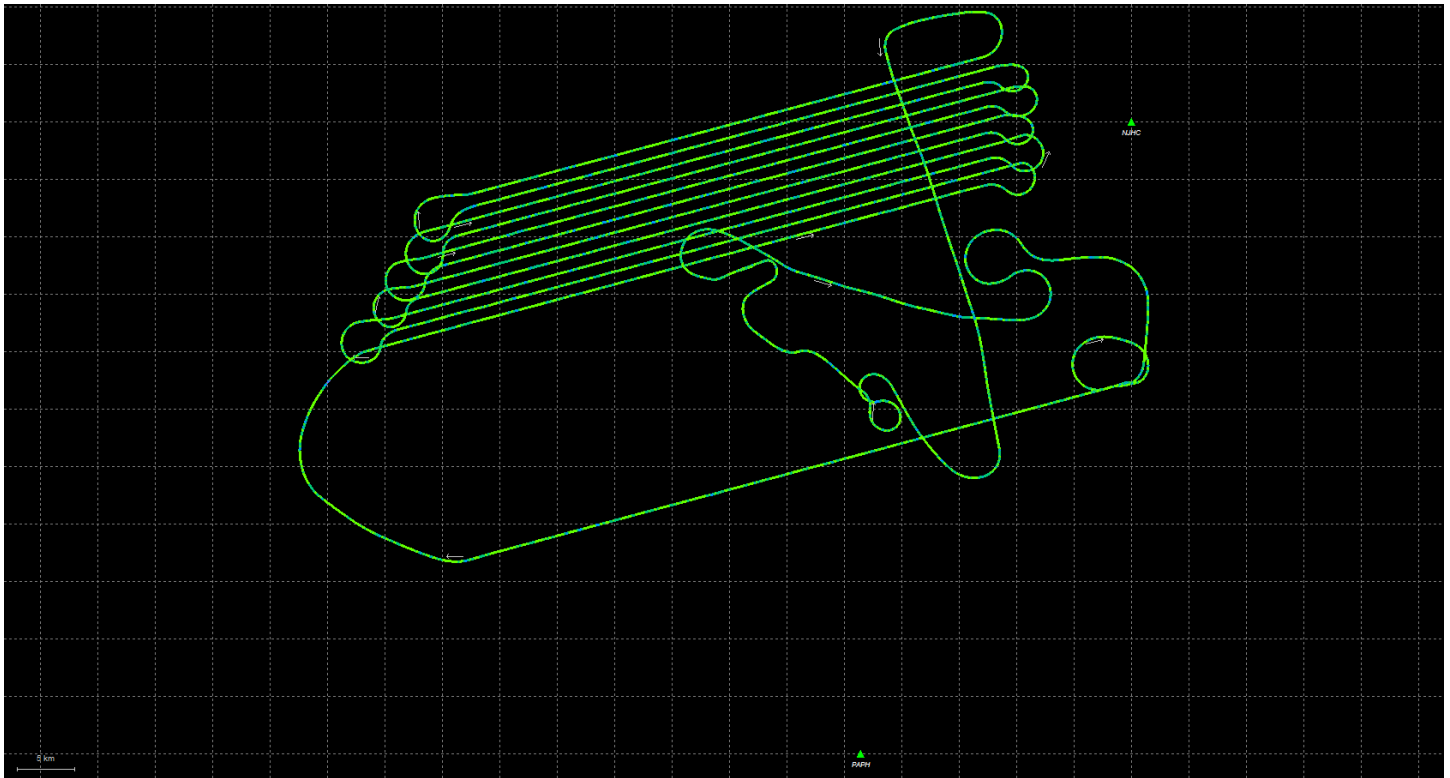

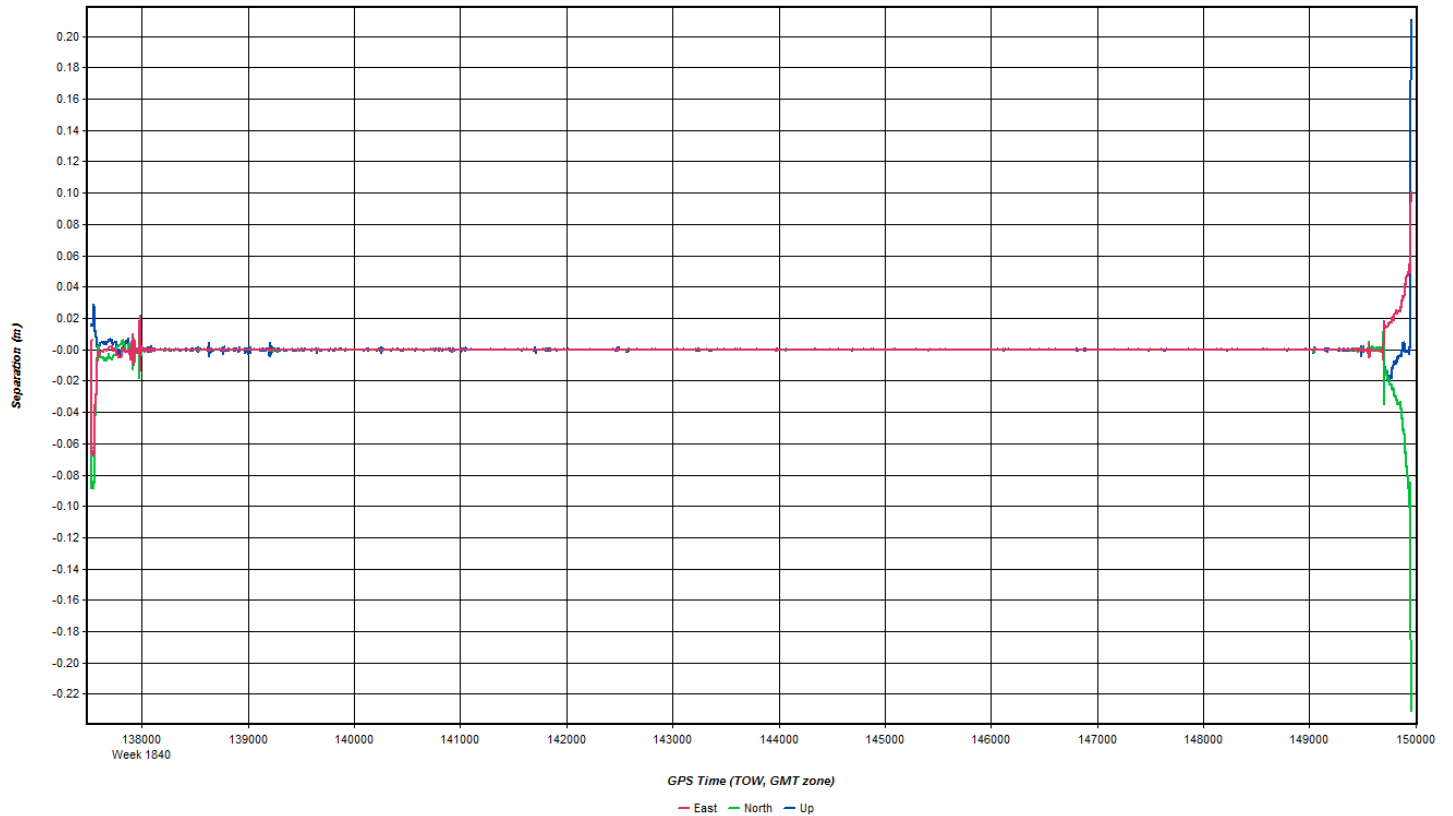
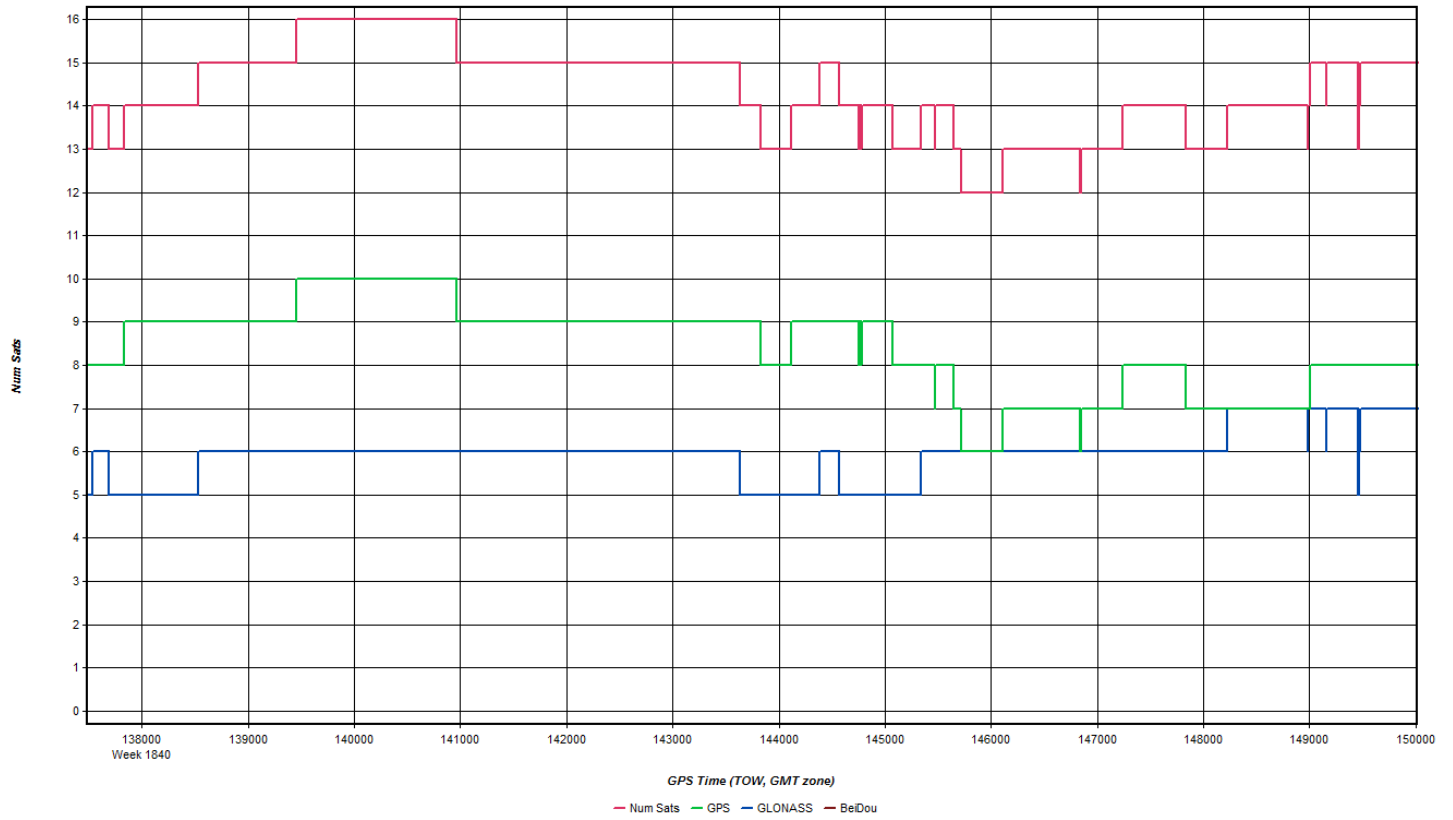

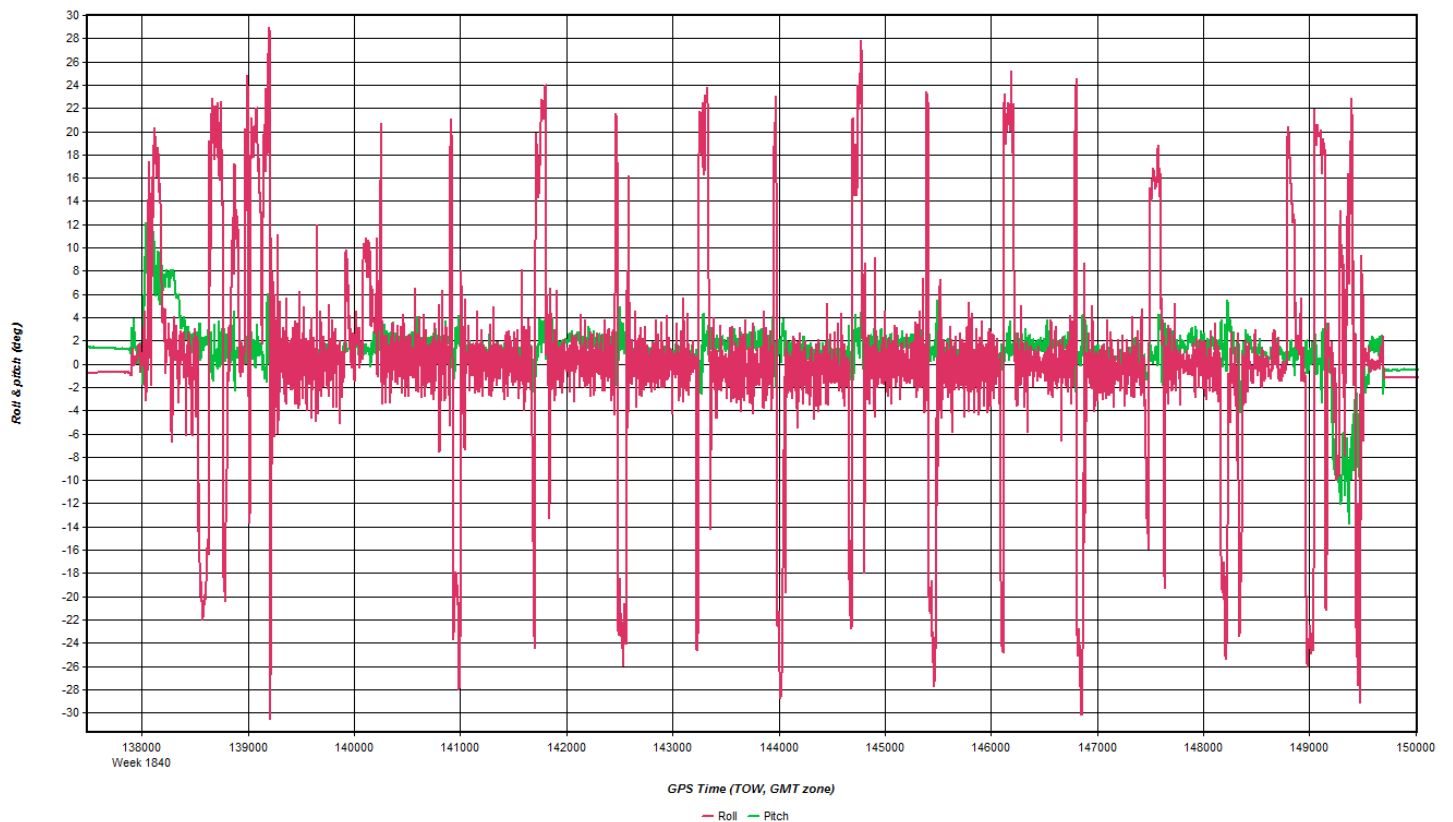
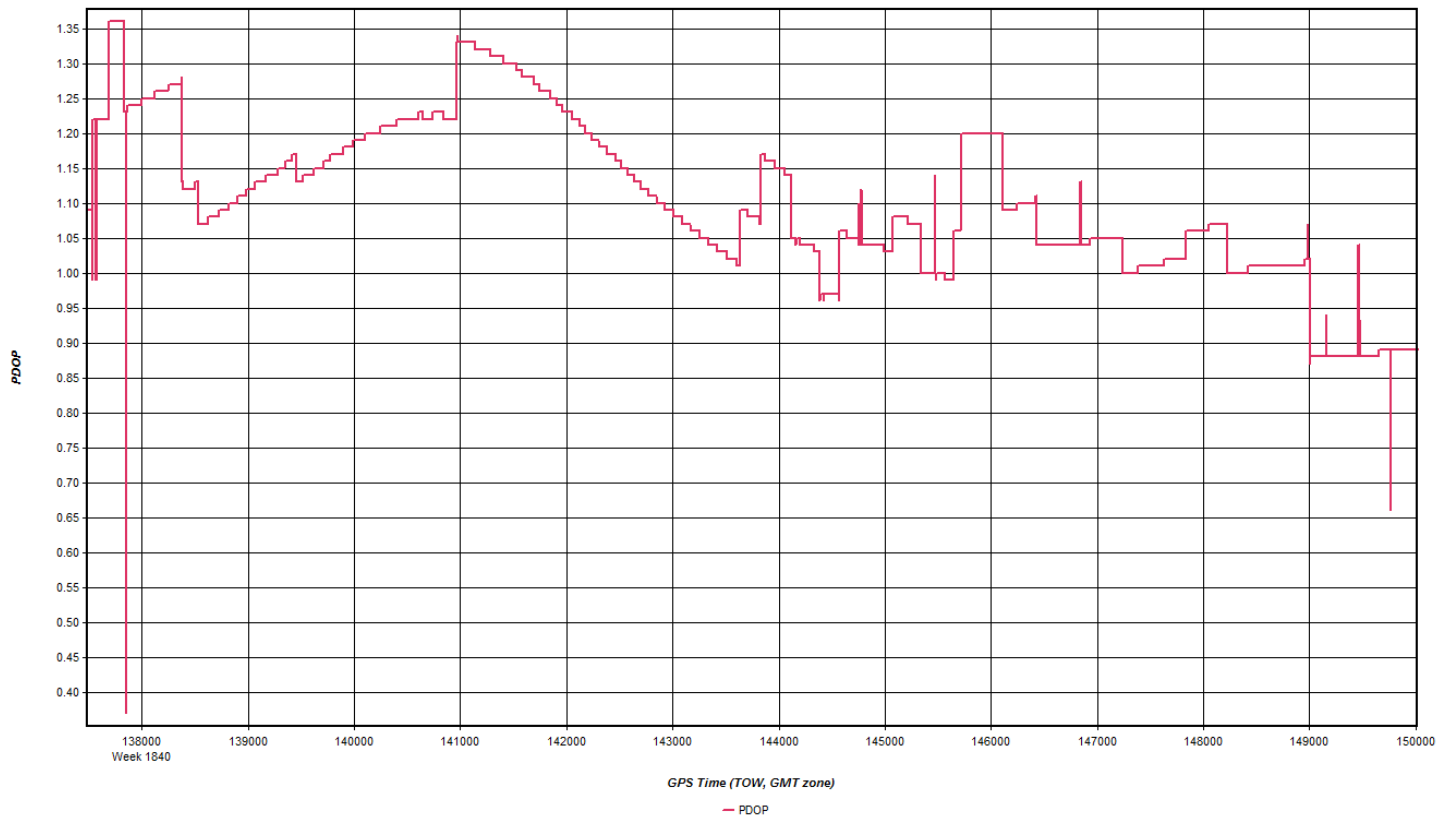

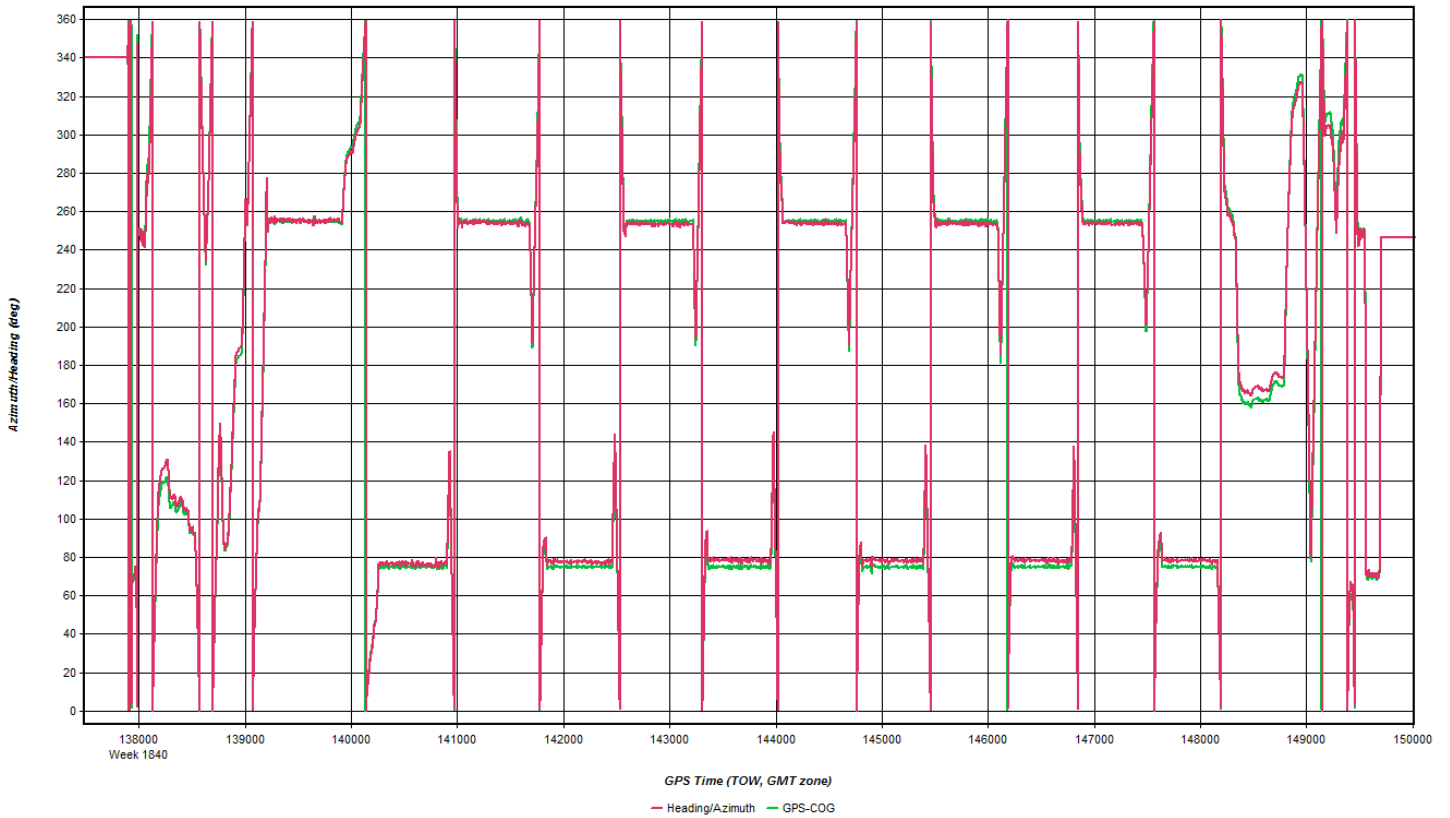

**Coordinate/Antenna Settings**

Master Remote

Base Station  
 1: NJHC Name: NJHC  Disabled  
 File: D:\Proc\26236\_DVRPC\3P60\20150413\_140918\njhc1030.gpb

Coordinates  
 Latitude: North 40 30 05.80472   
 Longitude: West 74 54 04.01548   
 Ellipsoidal height: 95.918 m   
 Datum: NAD83(2011)

Antenna Height  
 From station file: LEIAT504GG, LEIS   
 Antenna profile: LEIAT504GG, LEIS   
 Measured height: 0.000 m  
 ARP to L1 offset: 0.087 m  
 Applied height: 0.087 m  
 Measured to:  
 ARP  
 L1 Phase Centre

Coordinate/Antenna Settings

Master Remote

Base Station  
2: PAPH Name: PAPH  Disabled  
File: D:\Proc\26236\_DVRPC\3P60\20150413\_140918\paph1030.gpb

Coordinates  
Latitude: North 40 00 47.34854 Compute from PPP  
Longitude: West 75 10 34.78766 Enter Grid Values  
Ellipsoidal height: 27.809 m Enter MSL Height  
Datum: NAD83(2011) Datum Options  
Select From Favorites Add To Favorites Use Average Position

Antenna Height  
From station file: LEIAX1202GG, NONE View STA File  
Antenna profile: LEIAX1202GG Info

Measured height: 0.000 m  
ARP to L1 offset: 0.063 m  
Applied height: 0.063 m

Measured to  
 ARP  
 L1 Phase Centre  
Compute From Slant

OK Cancel

# Flight Log

Scanned by CamScanner

6234.2 → 8237.4

OPERATORS FLIGHT LOG

MISSION: S 0565 DVRPC		DATE: 4/13/15		LEICA ALS-70						
PILOT: 26236 Young		OPERATOR: Rolles		AIRCRAFT: N226E						
PROJECT NUMBER	LINE NO. & Hdg	GND SPEED (KTS)	FREQ Hz	SCAN ANGLE	PRF kHz	FIXED GAIN	ALT (m)	START TIME	STOP TIME	REMARKS
26236								14:11	14:16	Static Start
								14:20		T/O
re	1038 268	166	52	40	352	N/A	7.6K	14:50	14:51	Figure 9 @ 14:23z
	1020 87	165						14:57	15:08	
	1019 268	160						15:10	15:21	
	1018 87	167						15:24	15:33	
	1017 268	163						15:36	15:40	
	1016 87	167						15:49	15:59	
	1015 268	163						16:01	16:11	
	1014 87	166						16:13	16:23	
	1013 268	164						16:25	16:34	
	1012 87	165						16:37	16:46	
	1011 268	166						16:48	16:57	
	1010 87	172						17:00	17:09	Figure 8 @ 17:22
	file 172	159						17:12	17:20	Land
								17:31		Stabic Stop
								17:35	17:40	
<b>STATUS</b>		<b>TOTAL LINES</b>		<b>FLOWN</b>		<b>LEFT</b>		<b>RIGHT</b>		<b>NOTES:</b>
○	26236	42	12	9	2.7	.5	✓	14:11	17:40	
○							WKK			
○										

AERO-METRIC, INC. N 6216 Resource Drive Sheboygan Falls, WI 53085 PHONE: 920-467-2655 FAX: 888-253-6695 E-Mail: ainephoto@aerometric.com

# Base Station Log



### GPS OBSERVATION LOG

Station ID	KV5970	Date	4 / 13 / 15
Project Number	26236	Julian Date	103
Project Name	USGS DVRPC	Start Time	9 : 37 : 25 AM
Rcvr. Type	NovAtel DL-V3-L1L2	Stop Time	3 : 48 : 43 PM
Rcvr. S/N	7-0141418	Rcvr. File Name	00071030.PDC
Antenna Type	NovAtel	Observer	Dan Ro/tes
Antenna S/N	NAE12110035		

New or Existing  
 Mon.  New  
 Existing  
 Photo Taken:  
 Yes  No  
 Monument Type:  
 Spike  PK Nail  
 AM Washer  
 Other

Height Readings:  
 (Top of Monument to Bottom of Ground Plane)

Start	2	M.	Ft.
Stop	2	M.	Ft.
Mean	2	M.	Ft.

Monument Sketch and Notes:

Scanned by CamScanner

**Apr 14, 2015-A  
(N22GE, SN8239)**

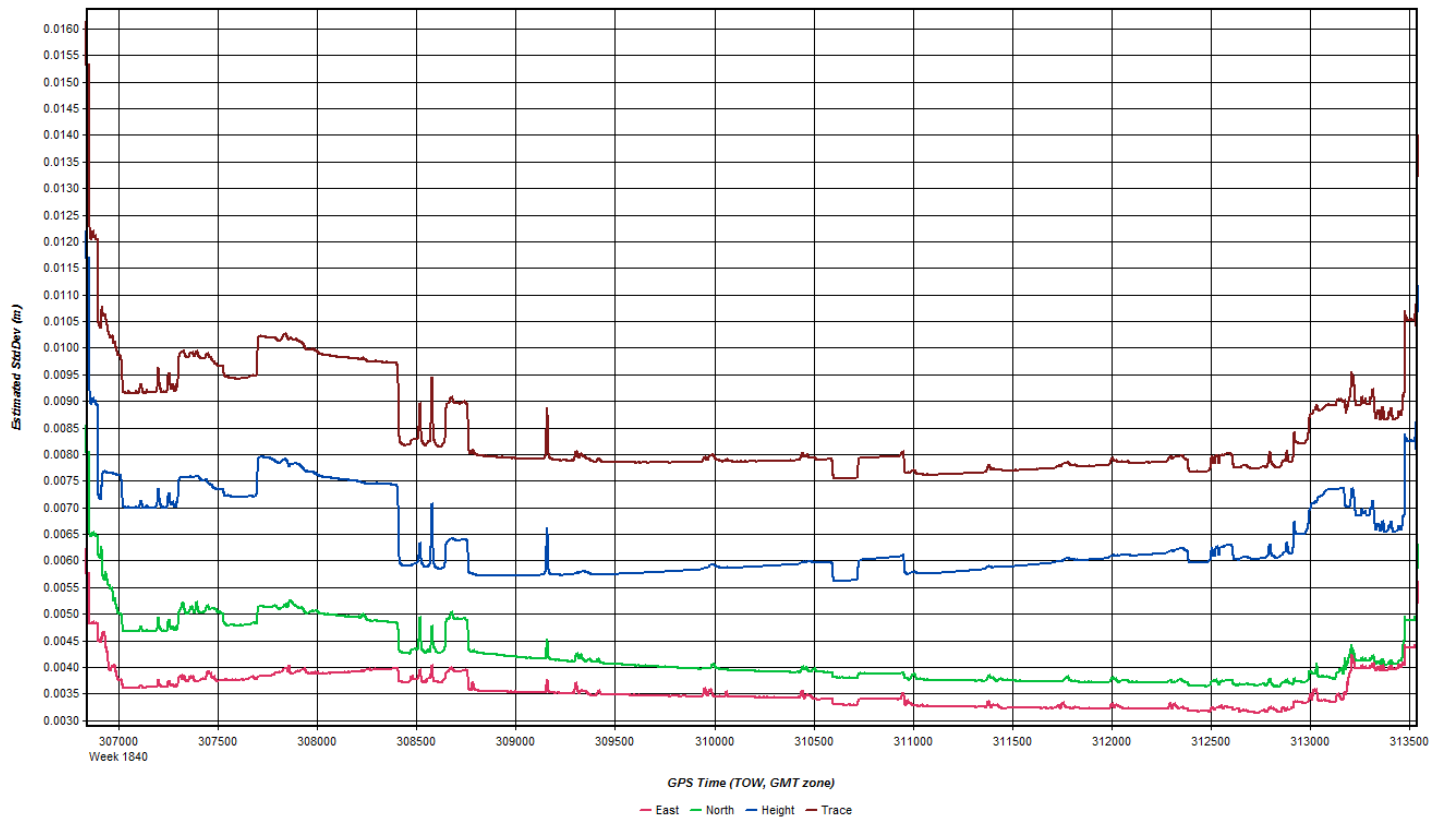
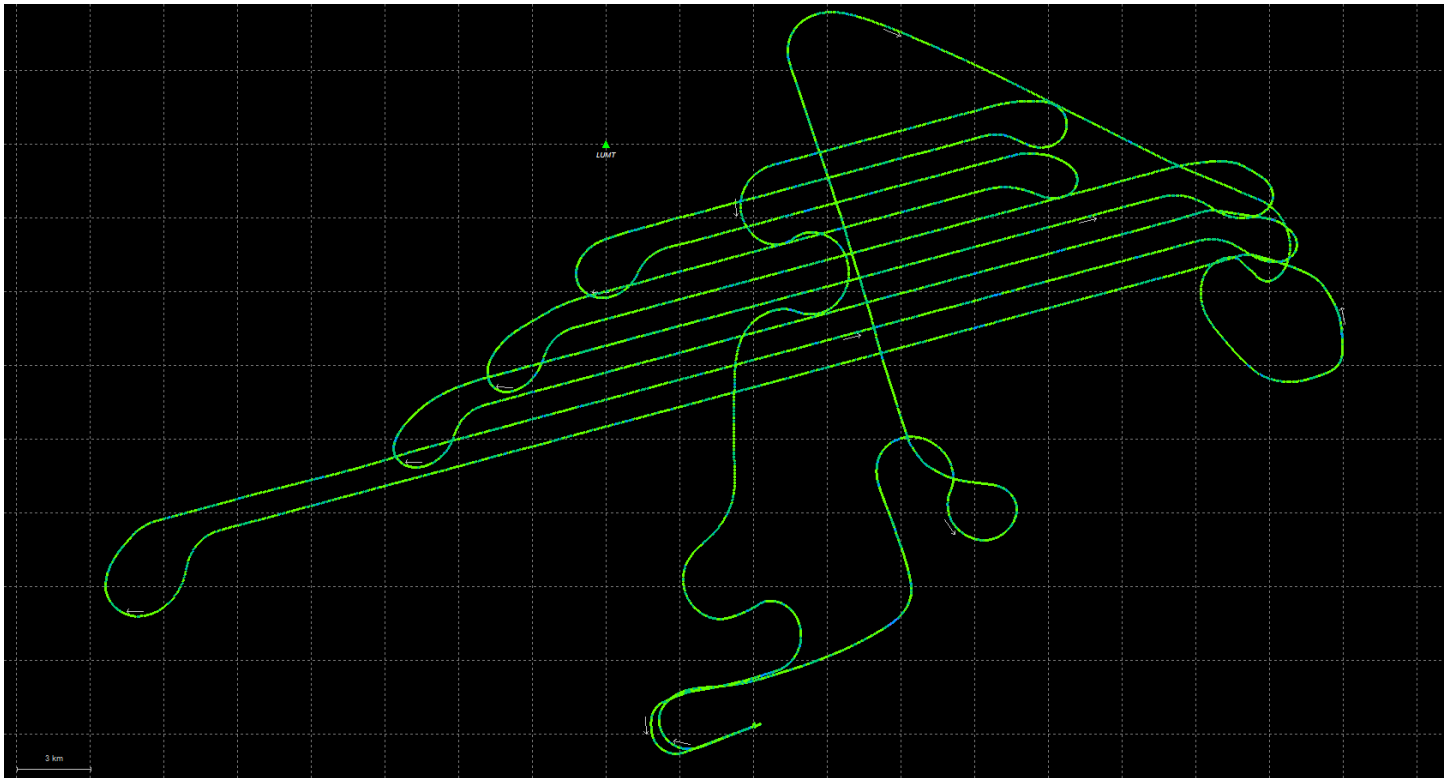

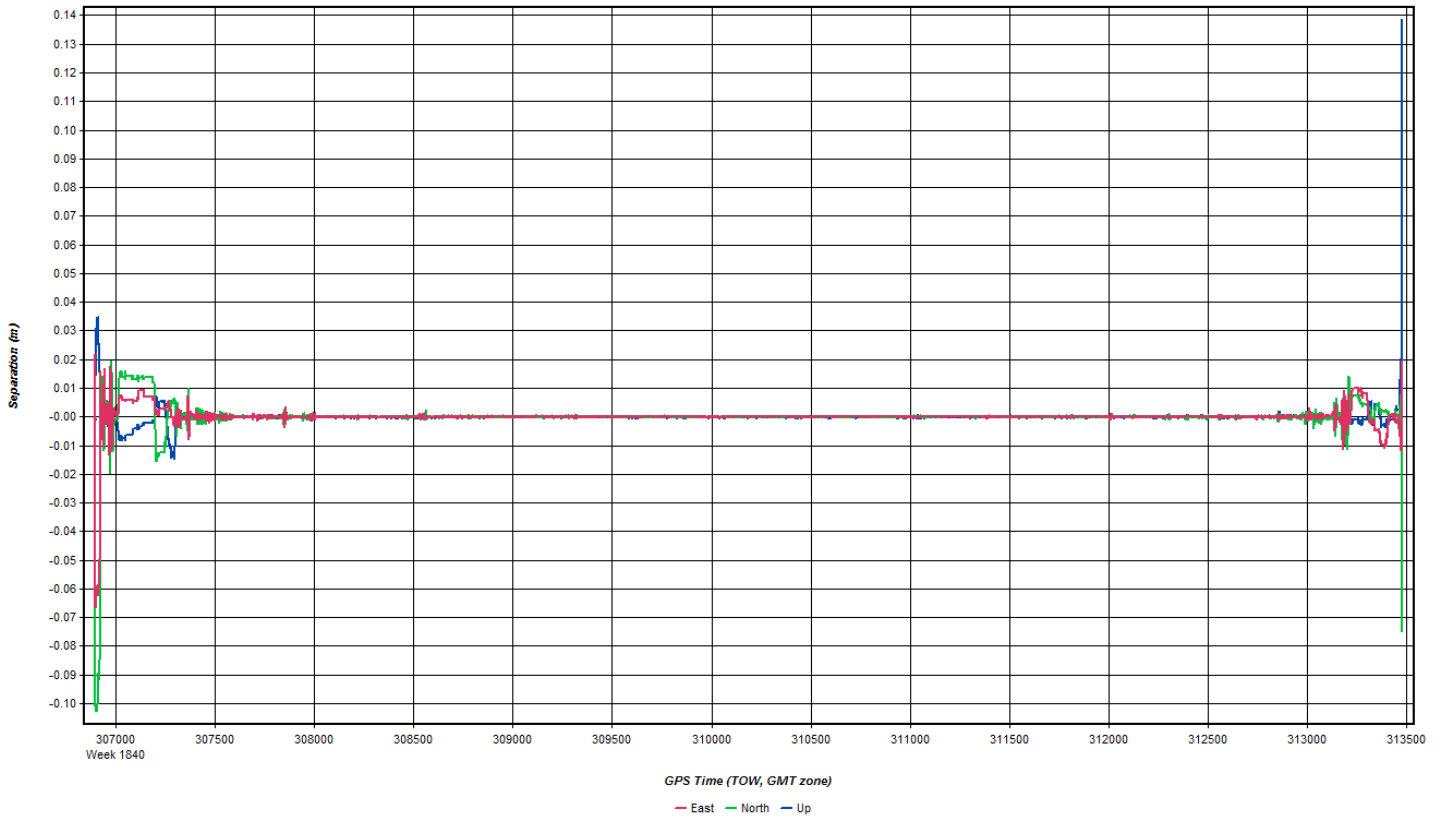
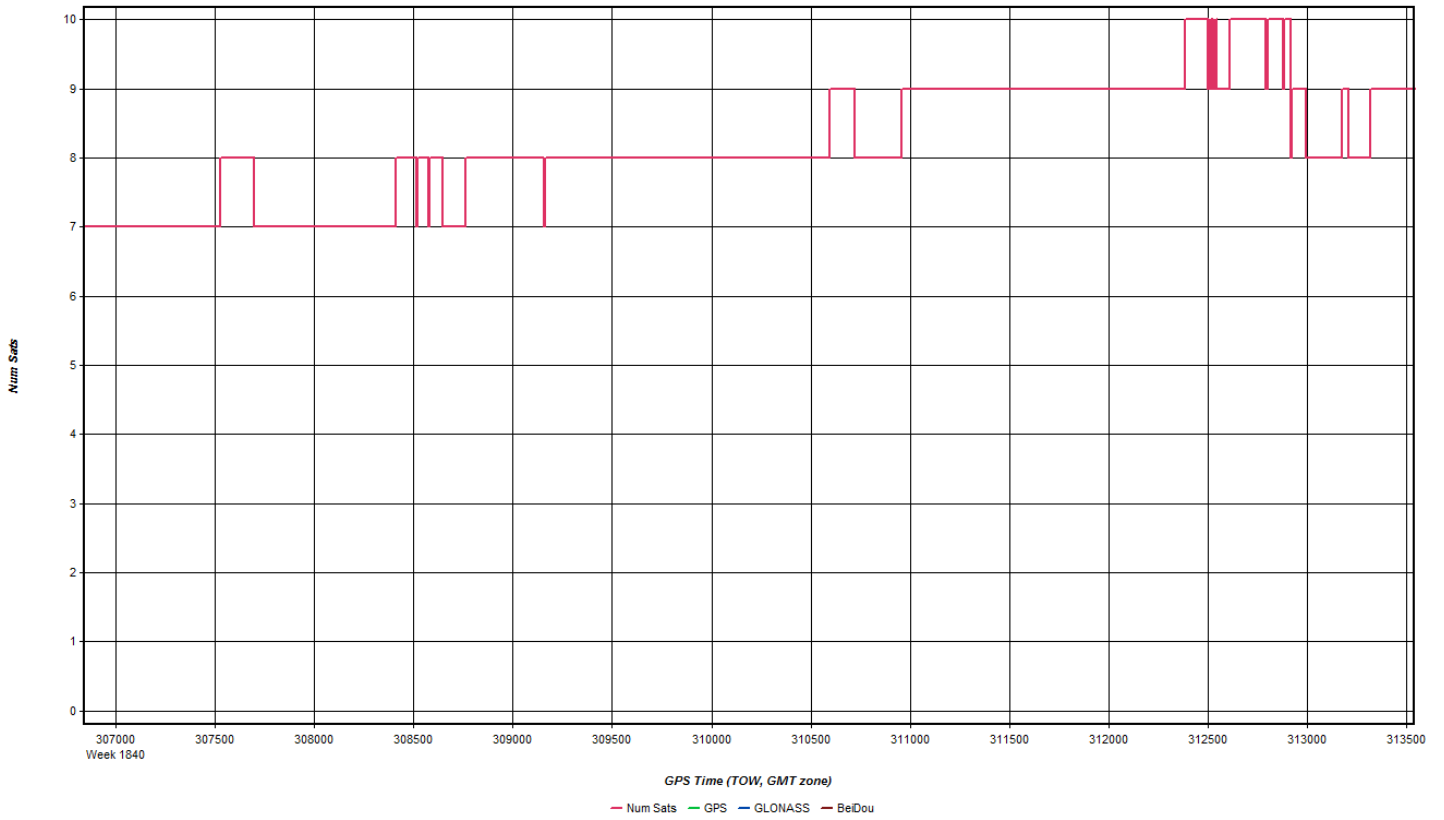

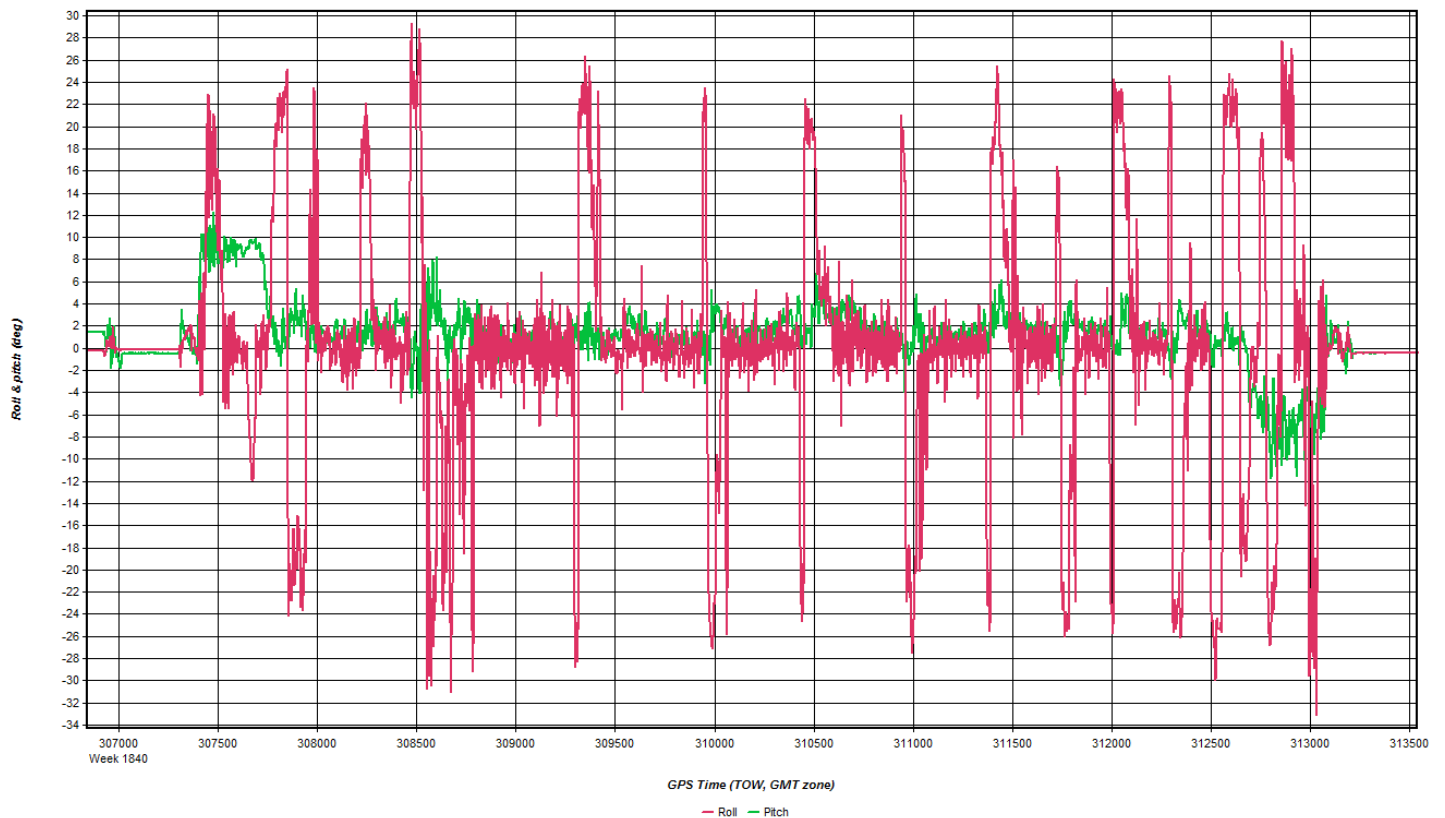
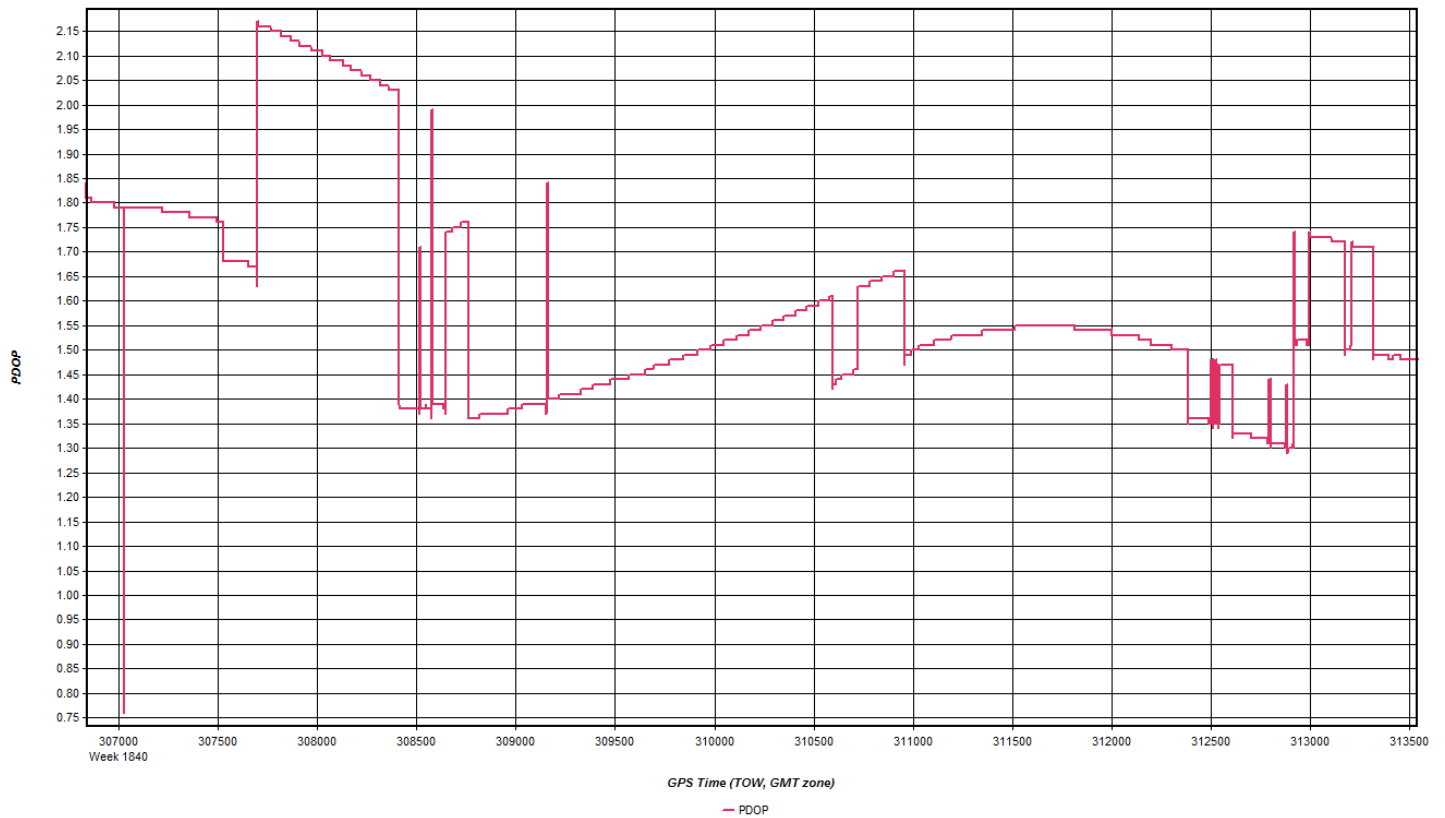

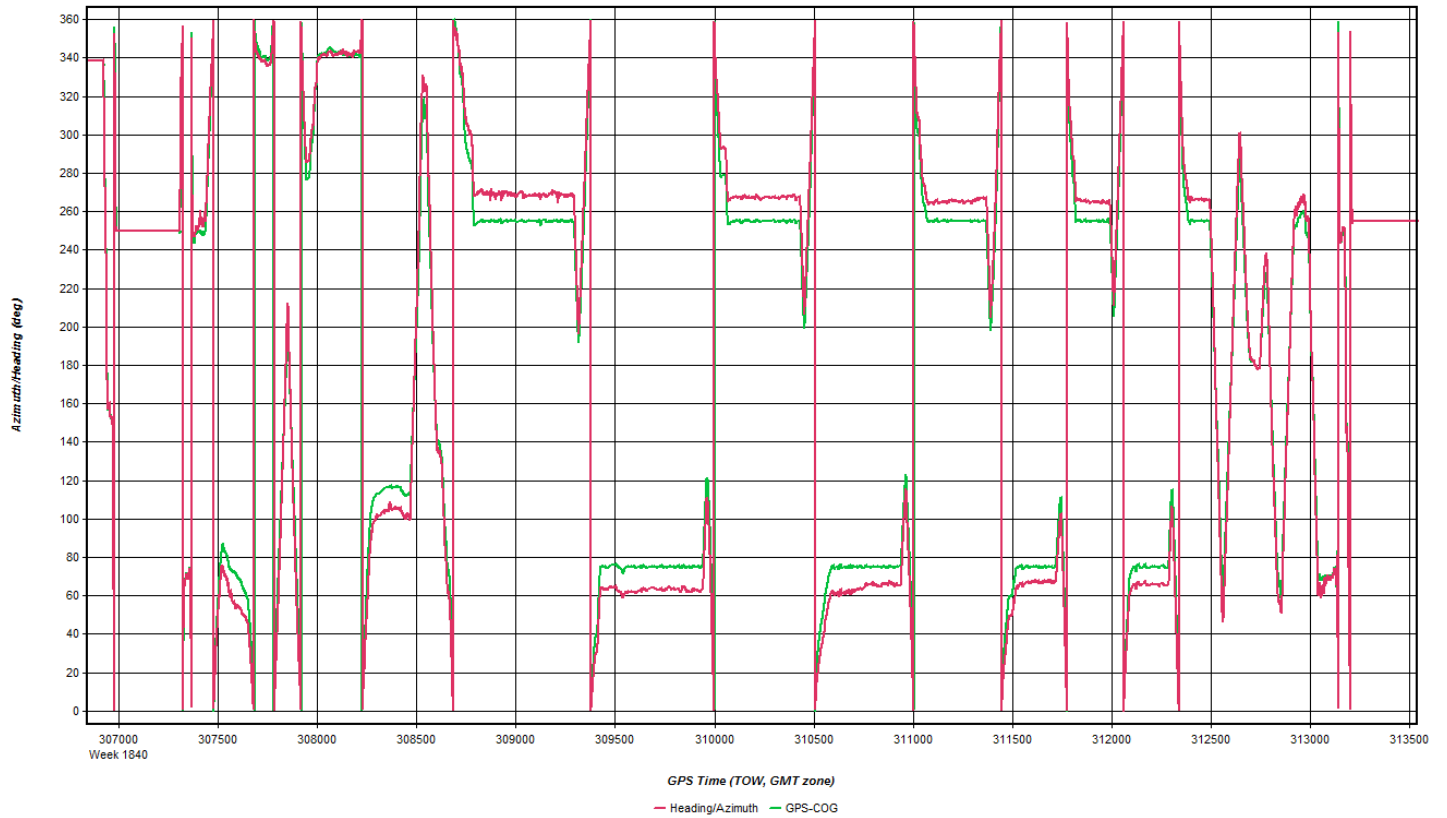

**Coordinate/Antenna Settings**

Master Remote

Base Station  
 1: LUMT Name: LUMT  Disabled  
 File: D:\Proc\26236\_DVRPC\NS6R\20150415\_131203\DVRPC\_KCK

Coordinates  
 Latitude: North 40 36 05.74811   
 Longitude: West 75 21 27.13397   
 Ellipsoidal height: 251.338 m   
 Datum: NAD83(2011)

Antenna Height  
 From station file: TRM29659.00, NONE   
 Antenna profile: TRM29659.00   
 Measured height: 0.000 m  
 ARP to L1 offset: 0.091 m  
 Applied height: 0.091 m  
 Measured to:  
 ARP  
 L1 Phase Centre

# Flight Log





# Base Station Log

### GPS OBSERVATION LOG

Station ID KV5970  
 Project Number 26236  
 Project Name USGS DVRPC QL2  
 Rcvr. Type NovAtel DL-V3-L1L2  
 Rcvr. S/N 7-0141418  
 Antenna Type NovAtel  
 Antenna S/N NAE12110035

Date 4 / 15 / 2015  
 Julian Date 105  
 Start Time 8 : 39 : 21 AM  
 Stop Time 11 : 15 : 38 AM  
 Rcvr. File Name 00071050.PDC  
 Observer Dan Rolfes

New or Existing  
 Mon.  New  
 Existing  
 Photo Taken:  
 Yes  No  
 Monument Type:  
 Spike  PK Nail  
 AM Washer  
 Other

Height Readings:  
 (Top of Monument to Bottom of Ground Plane)  
 Start 2 M. Ft.  
 Stop 2 M. Ft.  
 Mean 2 M. Ft.

Monument Sketch and Notes:

**Apr 14, 2015-B  
(N22GE, SN8239)**

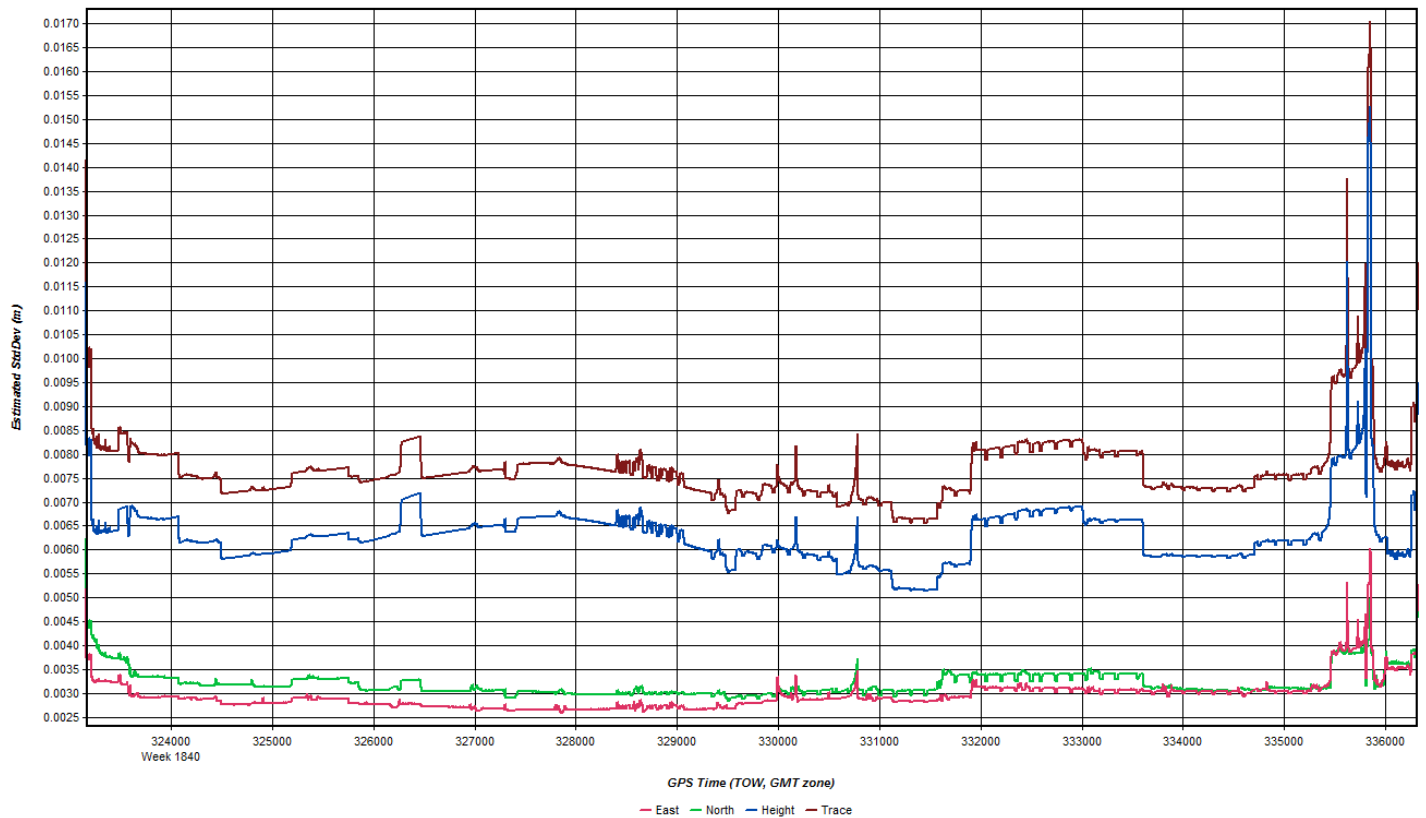
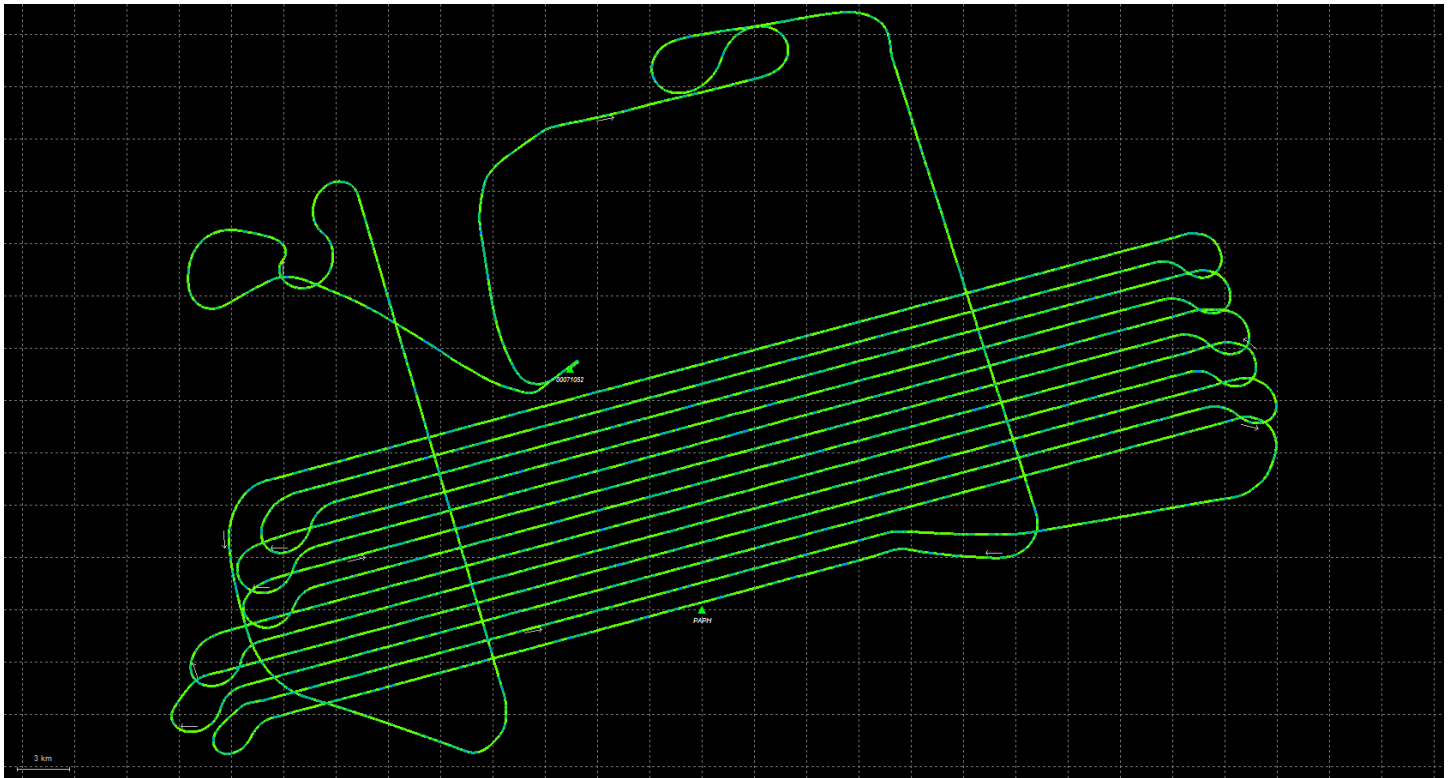

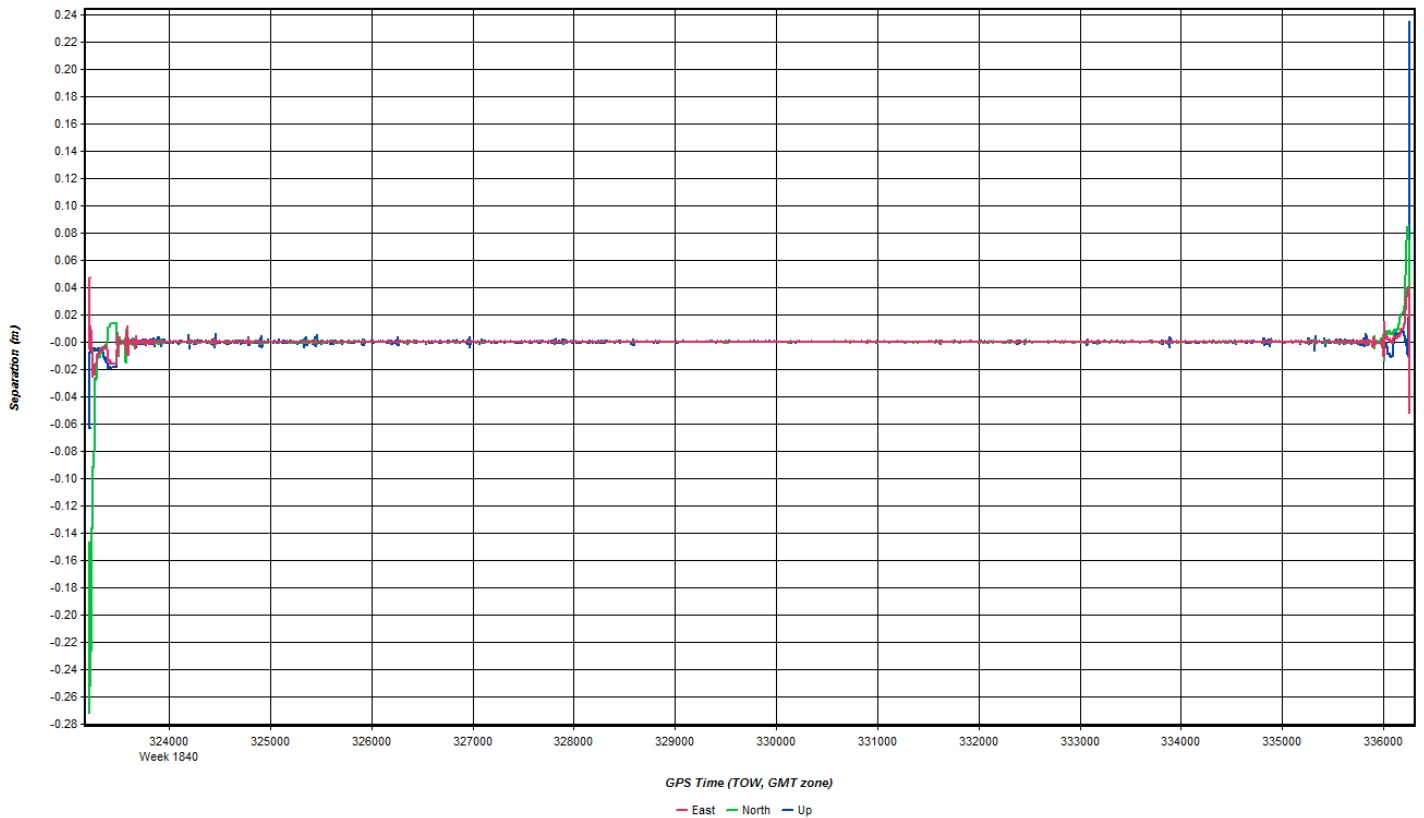
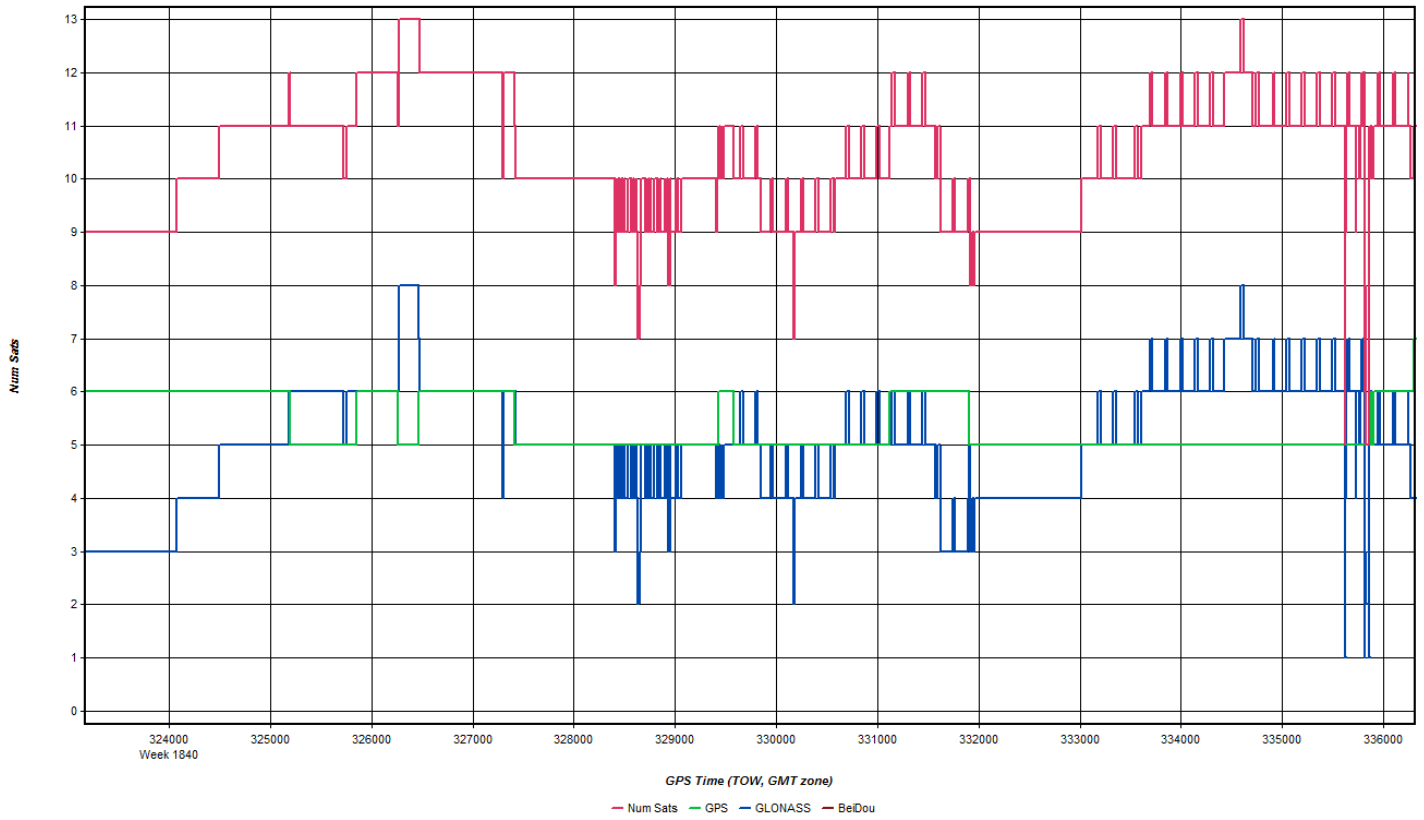

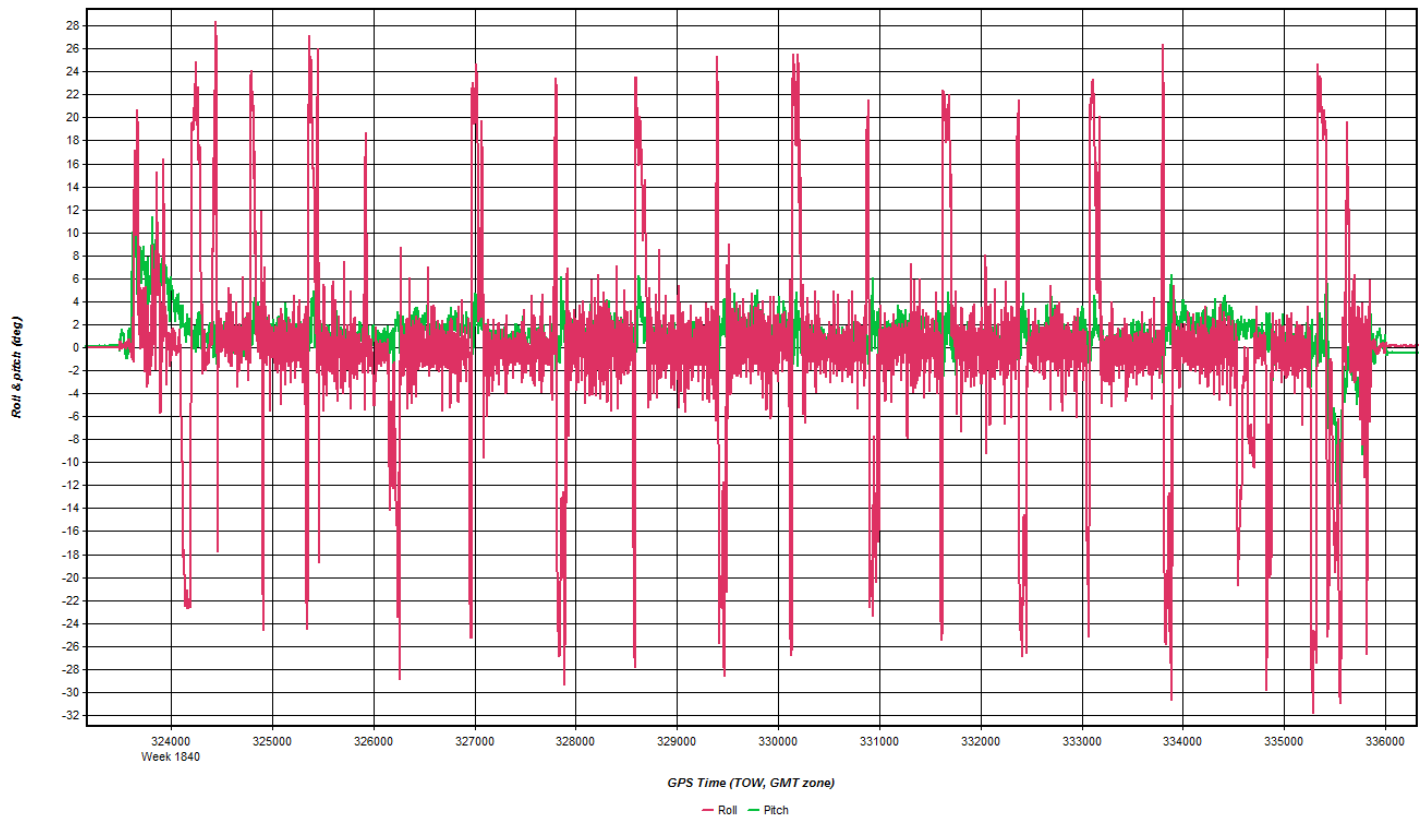
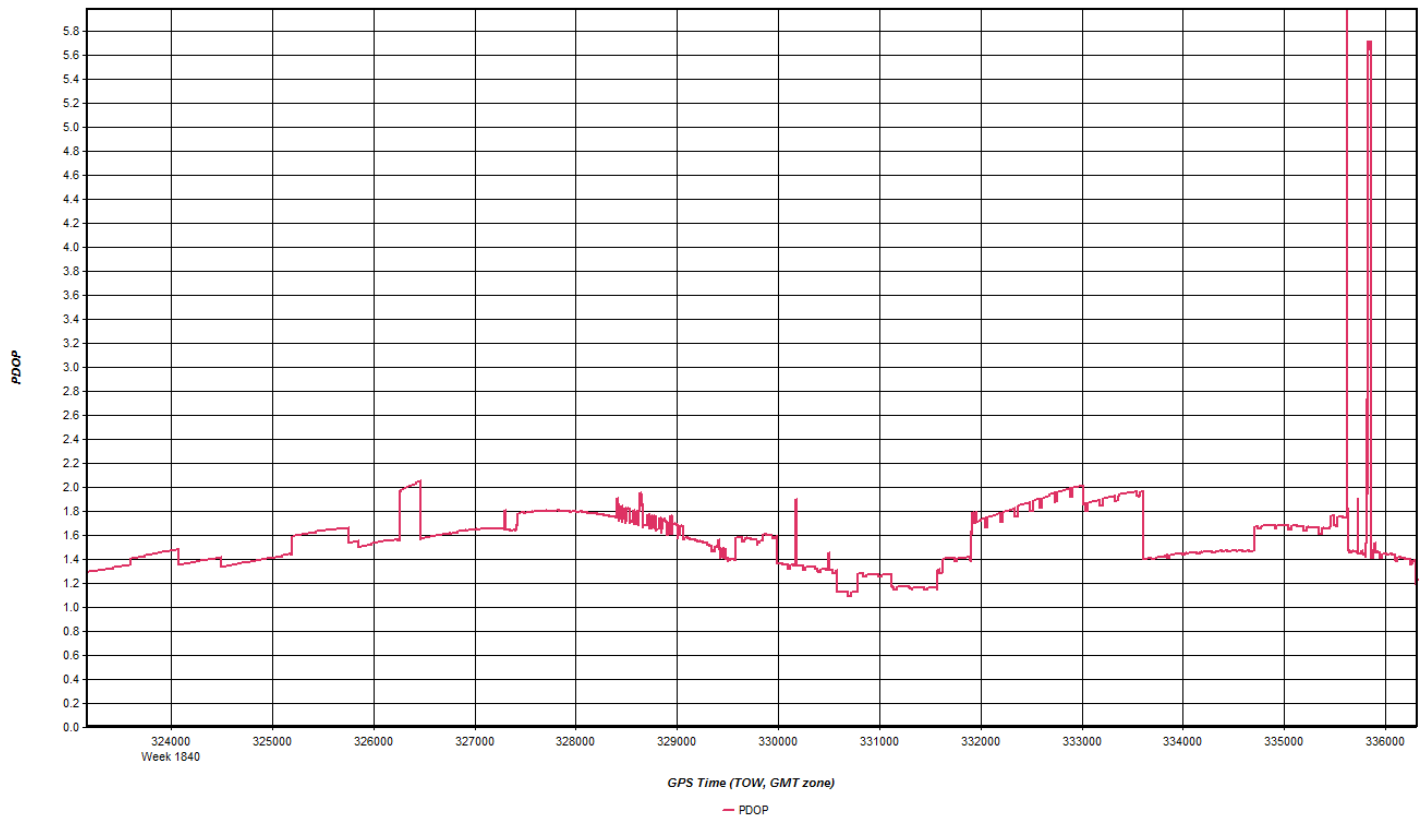

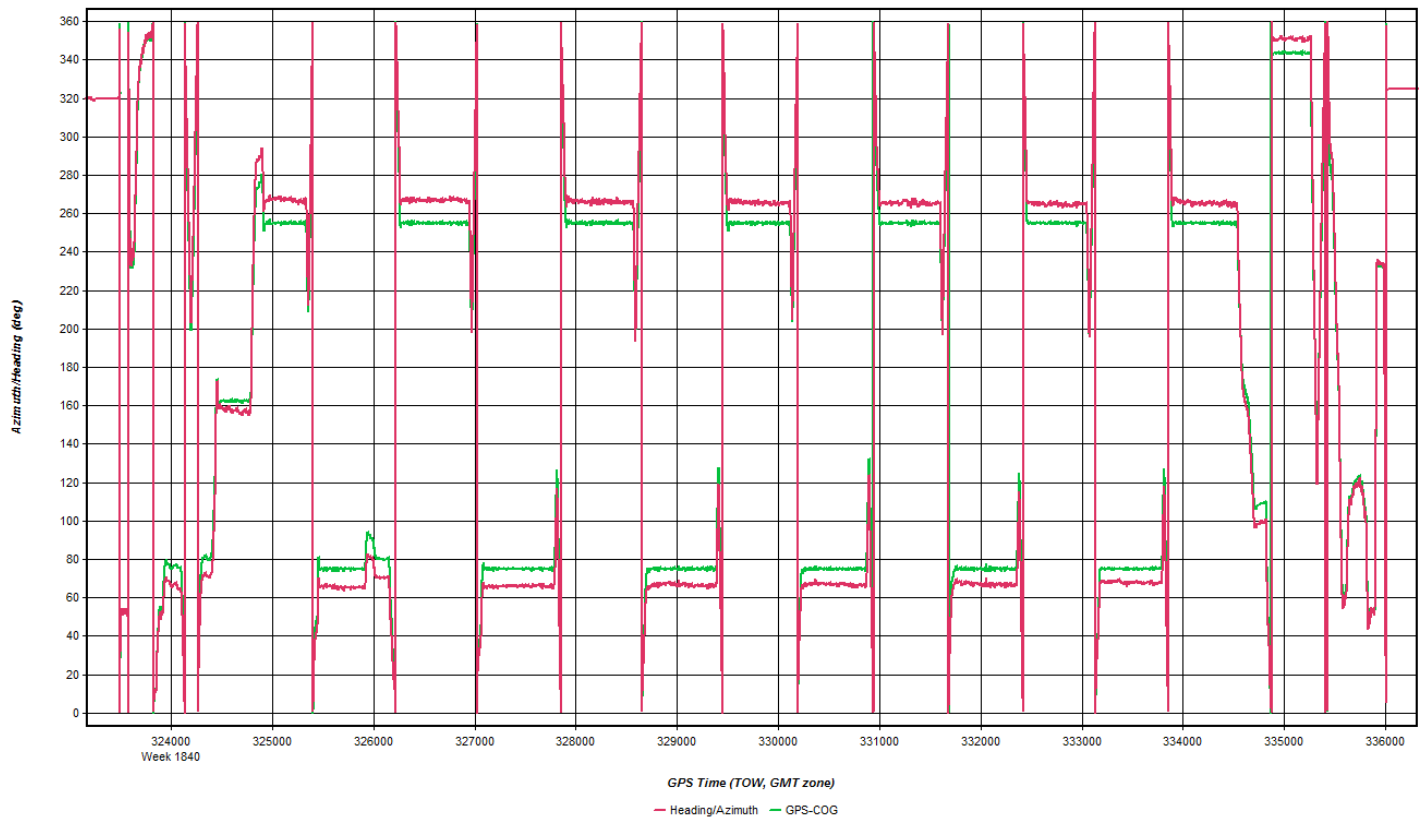

**Coordinate/Antenna Settings**

Master Remote

Base Station  
 Name: 00071052  Disabled  
 File: D:\Proc\26236\_DVRPC\NS6R\20150415\_174406\Base\000710

Coordinates  
 Latitude: North 40 08 11.65176   
 Longitude: West 75 15 51.95986   
 Ellipsoidal height: 54.132 m   
 Datum: NAD83(2011)

Antenna Height  
 From station file: N/A   
 Antenna profile: NOV702GG   
 Measured height: 2.000 m  
 ARP to L1 offset: 0.067 m  
 Applied height: 2.067 m  
 Measured to:  
 ARP  
 L1 Phase Centre

Coordinate/Antenna Settings

Master Remote

Base Station  
1: PAPH Name: PAPH  Disabled  
File: D:\Proc\26236\_DVRPC\NS6R\20150415\_174406\DVRPC\_KLO

Coordinates  
Latitude: North 40 00 47.34854 Compute from PPP  
Longitude: West 75 10 34.78766 Enter Grid Values  
Ellipsoidal height: 27.809 m Enter MSL Height  
Datum: NAD83(2011) Datum Options  
Select From Favorites Add To Favorites Use Average Position

Antenna Height  
From station file: LEIAX1202GG, NONE View STA File  
Antenna profile: LEIAX1202GG Info

Measured height: 0.000 m  
ARP to L1 offset: 0.063 m  
Applied height: 0.063 m

Measured to  
 ARP  
 L1 Phase Centre  
Compute From Slant

OK Cancel



# Flight Log

8139.4 → 8242.4  
OPERATORS FLIGHT LOG

YYYYMMDD\_TIME(GPS)

MISSION: S 1366 DVRPC Q12		DATE: 4/15/15 B		AIRCRAFT: LEICA ALS-70						
PILOT: Younga		OPERATOR: Rofes		M70 DRIVE						
PROJECT NUMBER	LINE NO. & Hdg	GND SPEED (KTS)	FREQ Hz	SCAN ANGLE	PRF KHZ	FIXED GAIN	ALT (m)	TIME START	TIME STOP	REMARKS
26236								17:46	17:51	Static Start
								17:53		T/O
	2026	175	52	40	352	N/A	7.4k	18:07	18:12	Figure 8 @ 18:02 z
	2024	267						18:15	18:22	
	2023	87						18:24	18:30	
	2022	267						18:37	18:44	
	2021	87						18:51	19:02	
	2020	267						19:05	19:15	
	2019	87						19:18	19:29	
	2018	267						19:31	19:41	
	2017	87						19:44	19:54	
	2016	267						19:56	20:06	
	2015	87						20:09	20:19	
	2014	267					7.2K	20:21	20:30	
	2013	87						20:33	20:42	
	2012	267						20:45	20:55	
	2025	356					7.3K	21:01	21:07	Figure 8 @ 21:08 z
								21:17		
								21:20	21:25	Static Stop
STATUS	TOTAL LINES	FLOWN	AIRCRAFT		FERRY	STATIC	START	STOP	NOTES:	
			LEFT	SITE						
○	23	15	8	3.0	0.4	✓	17:46	21:25		
○						WXX				
○										

AERO-METRIC, INC., N.6216 Resource Drive Sheboygan Falls, WI. 53085 PHONE: 920-467-2655 FAX: 888-253-6695 E-Mail: amphoto@aerometric.com

# Base Station Log

### GPS OBSERVATION LOG

Station ID	<u>KLOM airport</u>	Date	<u>9/15/2015</u>
Project Number	<u>26236</u>	Julian Date	<u>105</u>
Project Name	<u>USGS DURPC Q12</u>	Start Time	<u>1:33:53 PM</u>
Rcvr. Type	<u>Novatel-DLV3-L112</u>	Stop Time	<u>5:29:23 PM</u>
Rcvr. S/N	<u>7-0141149</u>	Rcvr. File Name	<u>00071052.PDC</u>
Antenna Type	<u>Novatel GPS-202-66</u>	Observer	<u>Don Rolles</u>
Antenna S/N	<u>NAE12110034</u>		

New or Existing  
 Mon.  New  
 Existing  
 Photo Taken:  
 Yes  No  
 Monument Type:  
 Spike  PK Nail  
 AM Washer  
 Other

Height Readings:  
 (Top of Monument to Bottom of Ground Plane)

Start	<u>2</u> M.	Ft.
Stop	<u>2</u> M.	Ft.
Mean	<u>2</u> M.	Ft.

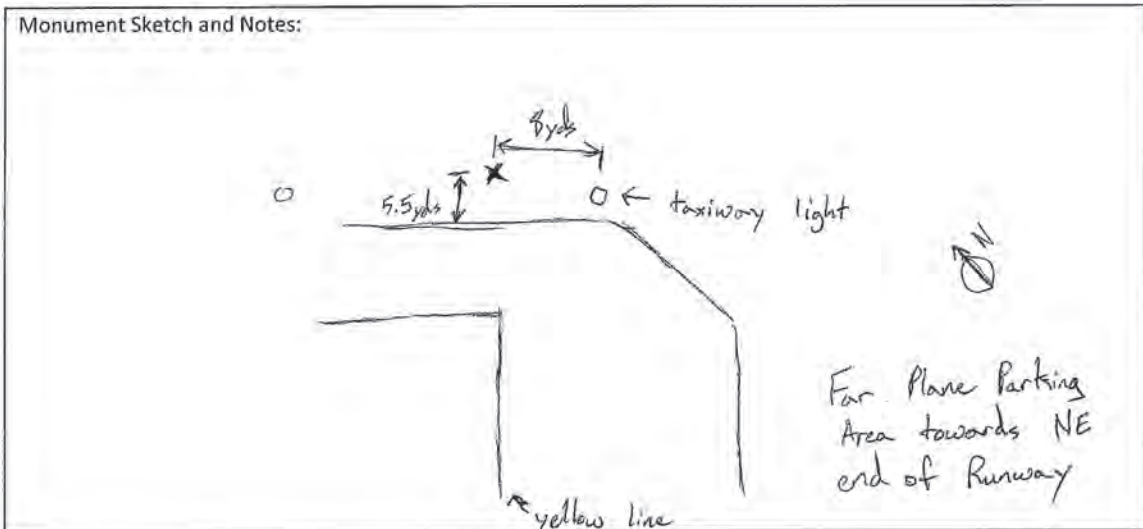

**Apr 16, 2015-A  
(N22GE, SN8239)**

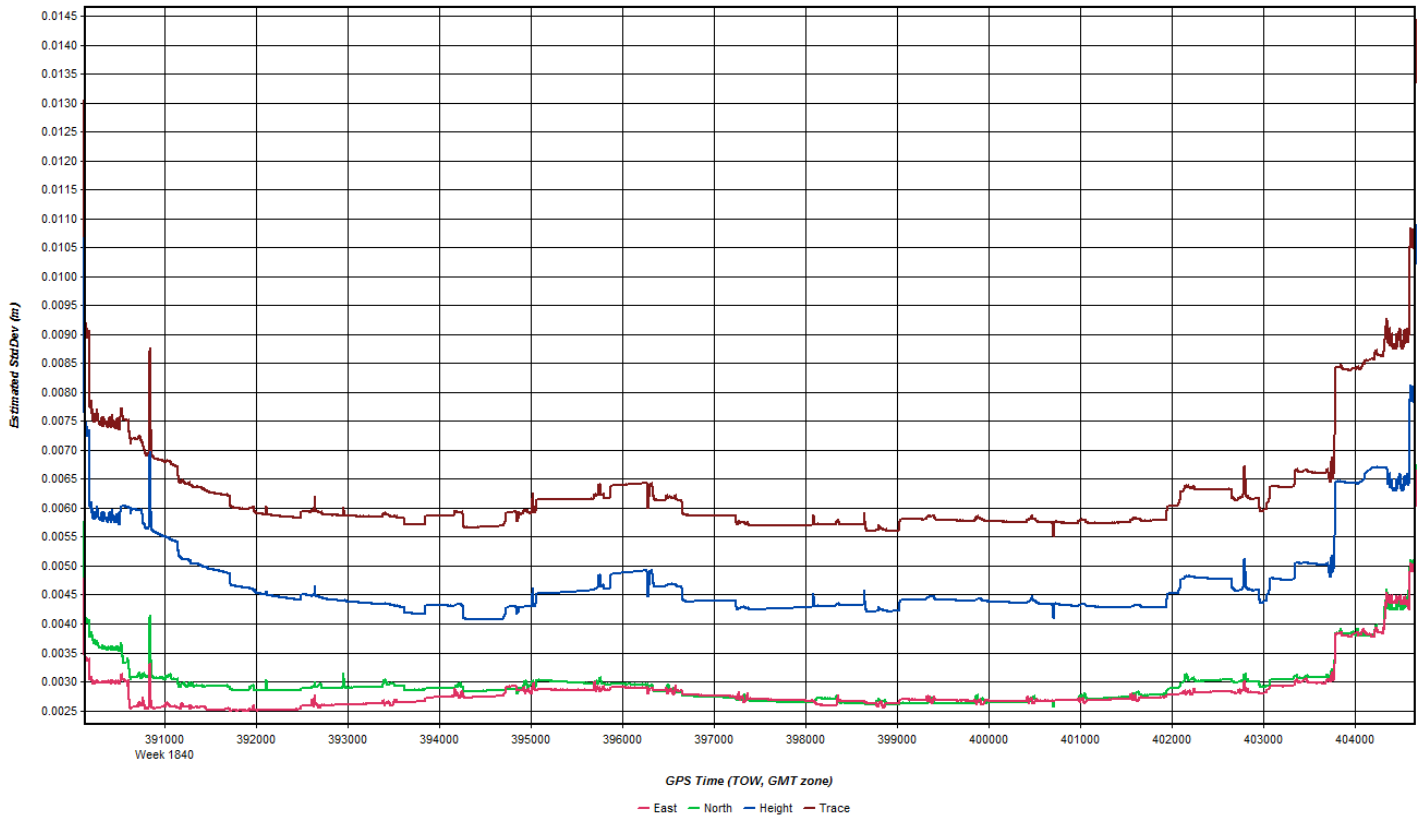
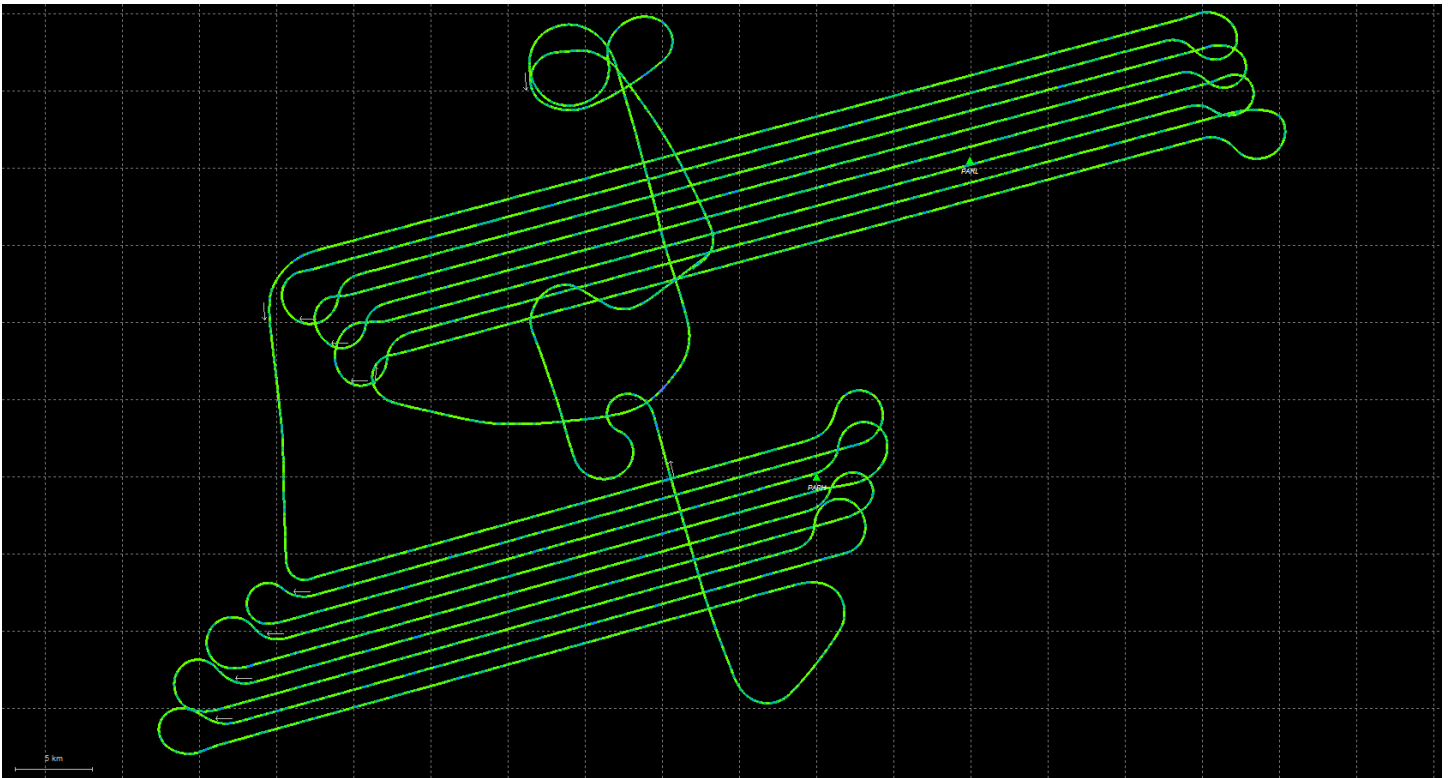

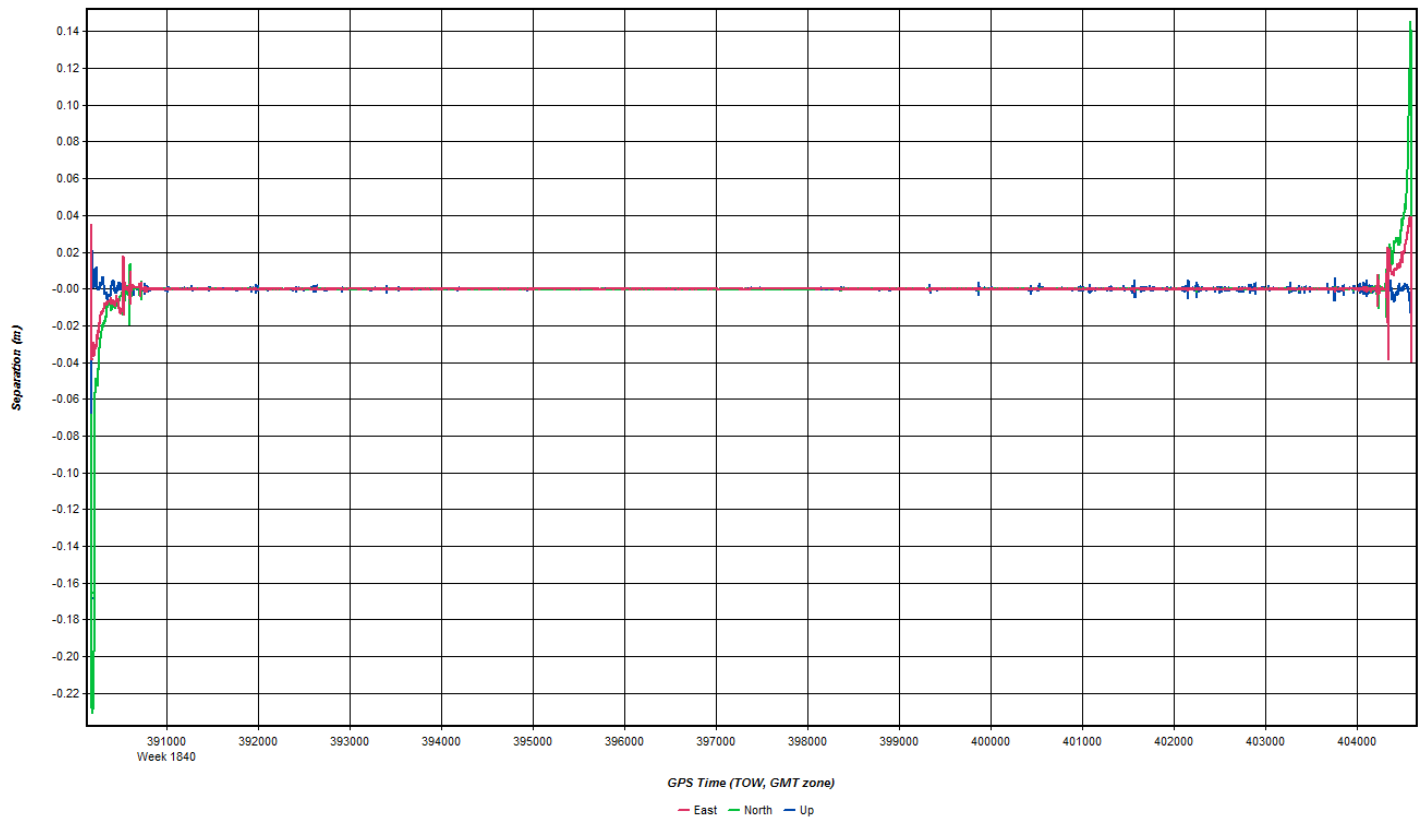
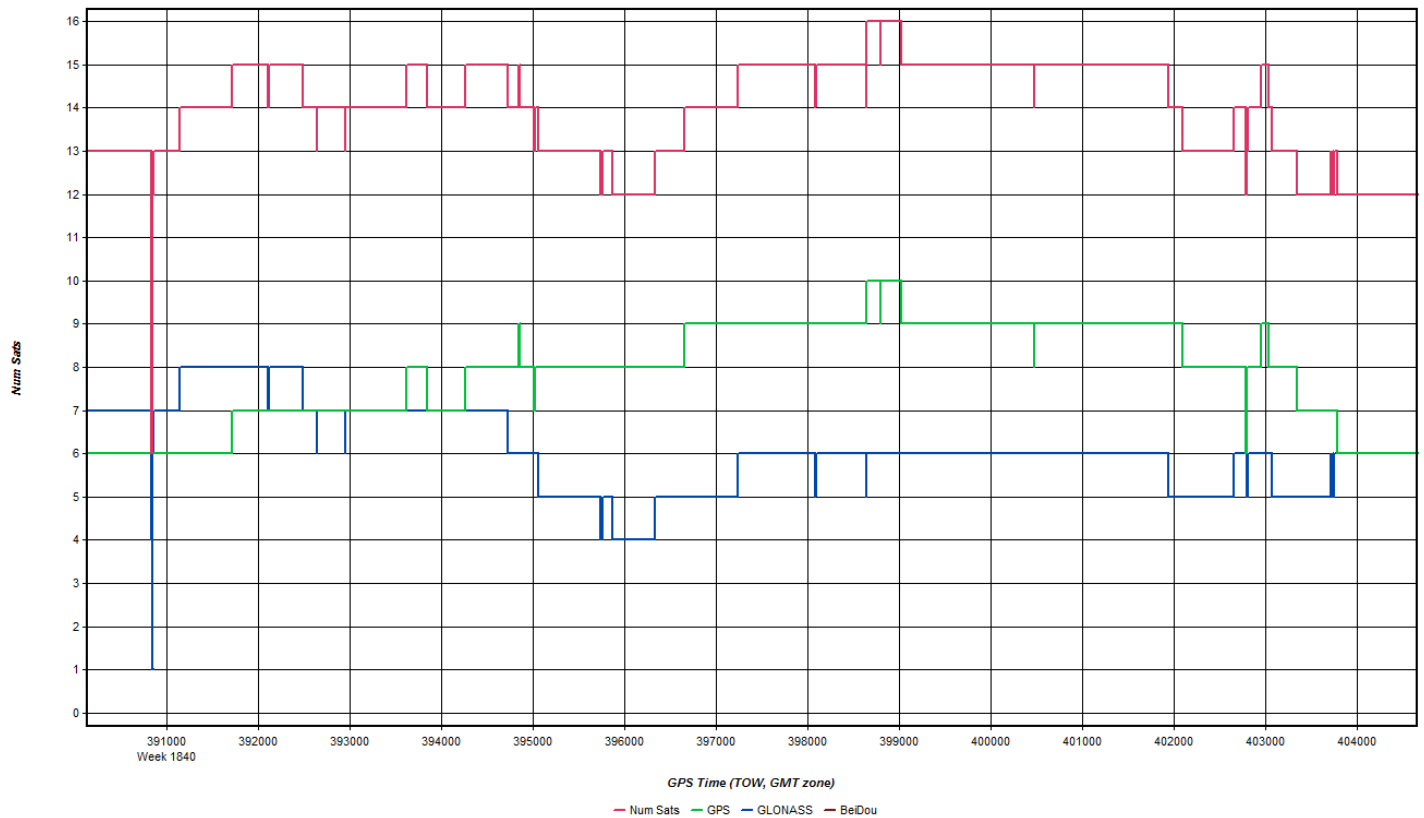

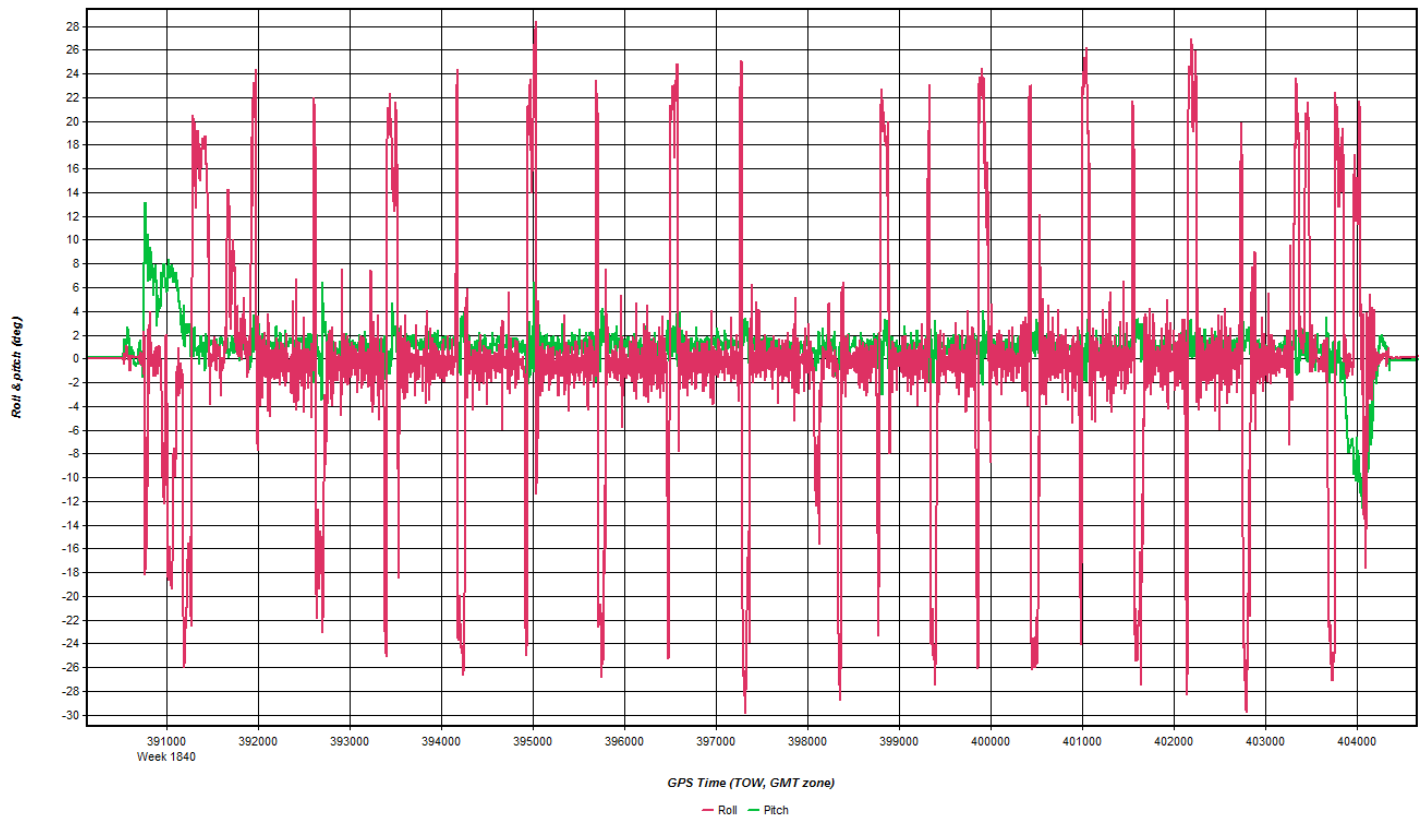
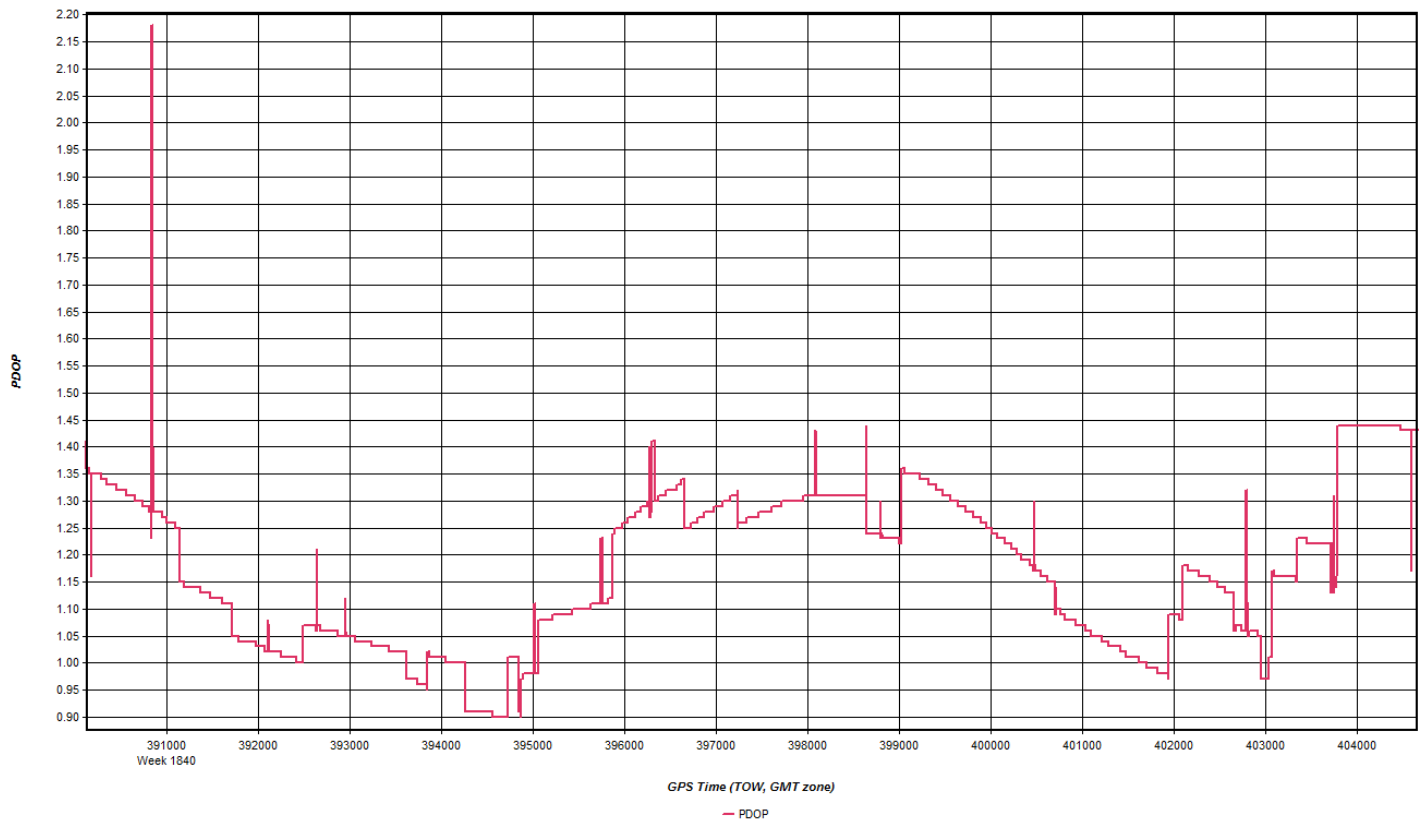



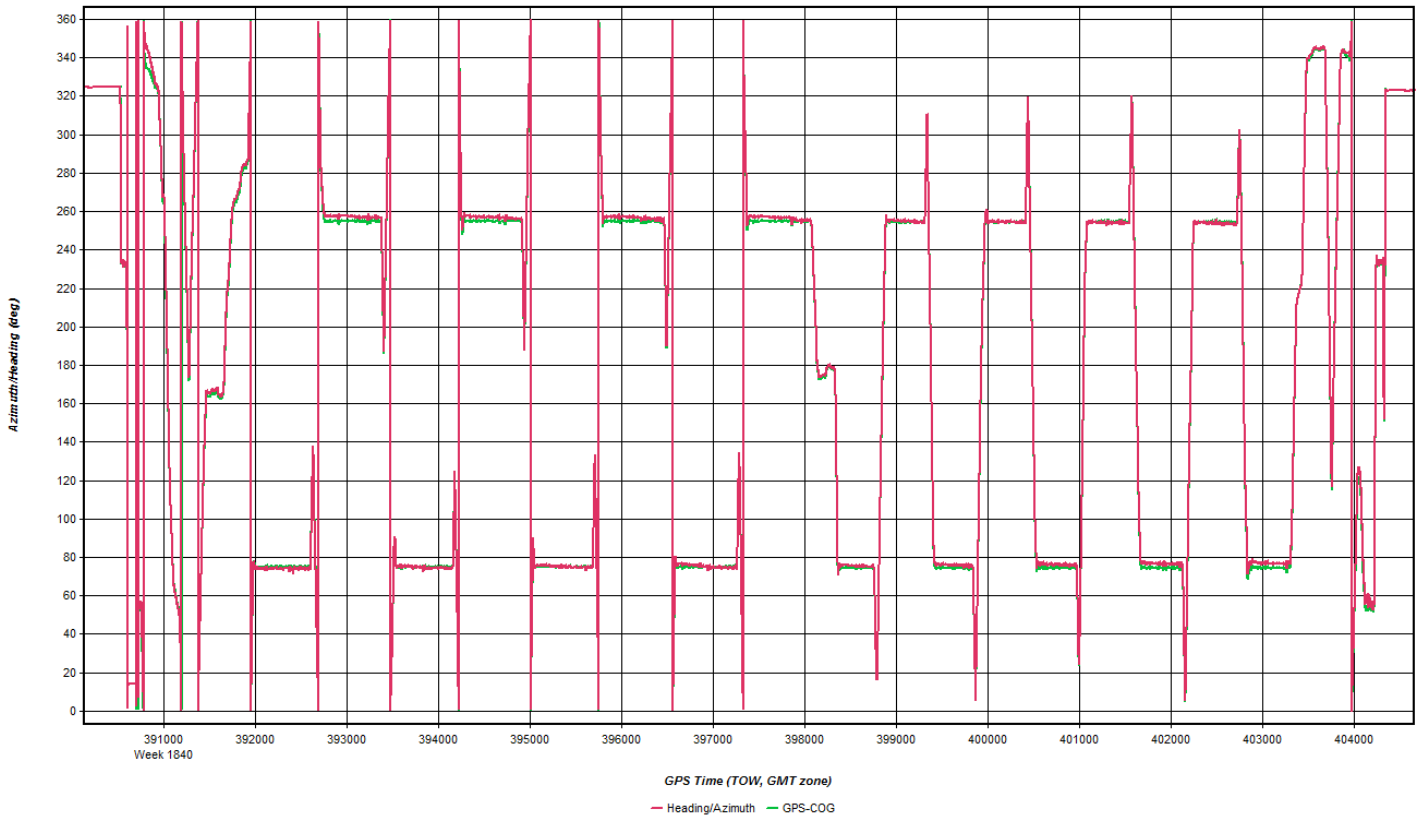

**Coordinate/Antenna Settings**

Master Remote

Base Station  
 1: PAPH Name: PAPH  Disabled  
 File: D:\Proc\26236\_DVRPC\NS6R\20150416\_122006\paph1060.gpt

Coordinates  
 Latitude: North 40 00 47.34854   
 Longitude: West 75 10 34.78766   
 Ellipsoidal height: 27.809 m   
 Datum: NAD83(2011)

Antenna Height  
 From station file: LEIAX1202GG, NONE   
 Antenna profile: LEIAX1202GG   
 Measured height: 0.000 m  
 ARP to L1 offset: 0.063 m  
 Applied height: 0.063 m  
 Measured to:  
 ARP  
 L1 Phase Centre

Coordinate/Antenna Settings

Master Remote

Base Station  
2: PARL Name: PARL  Disabled  
File: D:\Proc\26236\_DVRPC\NS6R\20150416\_122006\par1060.gpb

Coordinates  
Latitude: North 40 11 46.22401   
Longitude: West 75 03 35.66418   
Ellipsoidal height: 76.548 m   
Datum: NAD83(2011)

Antenna Height  
From station file: TRM57971.00, NONE   
Antenna profile: TRM57971.00   
Measured height: 0.000 m  
ARP to L1 offset: 0.067 m  
Applied height: 0.067 m  
Measured to:  
 ARP  
 L1 Phase Centre

OK Cancel

# Flight Log

8242.8 → 8246.5

**OPERATORS FLIGHT LOG**

MISSION: S USGS DURPC QLZ		DATE: 4/16/15A		LEICA ALS-70							
PILOT: Young		OPERATOR: Rolles		AIRCRAFT: N226E							
PROJECT NUMBER	LINE NO. & Hdg	GND SPEED (KTS)	FREQ Hz	SCAN ANGLE	PRF KHZ	FIXED GAIN	ALT (m)	TIME START	TIME STOP	MM70 DRIVE	REMARKS
26236								12:22	12:27		Static Start
								12:32			T/O
Witness FOI	tie	179	52	40	352	N/A	741K	12:44	12:47		Figure 8 @ 12:40
		2011						12:53	12:03		
		2010						13:06	13:15		
		2009						13:18	13:24		
		2008						13:31	13:41		
		2007						13:44	13:54		
		2006						13:57	14:07		
		2005						14:10	14:20		
		2004						14:23	14:34		
Bandywine API	4001	87						14:39	14:45		
	4002	267						14:48	14:54		
	4003	87						14:57	16:03		
	4004	267						15:06	15:13		
	4005	87						15:15	15:22		
	4006	267						15:25	15:32		
	4007	87						15:34	15:42		
	4008	267						15:44	16:51		
STATUS	TOTAL LINES	FLOWN	LEFT	SITE	AIRCRAFT FERRY	STATIC	START	STOP	NOTES:		
○ 26236 LOM	23	8	0	1.8	0.2	✓	12:22	16:24			
○ 26236 OLA	25	9	16	1.5	0.2	WAX					
○											

AERO-METRIC, INC., N.6216 Resource Drive Sheboygan Falls, WI. 53085 PHONE: 920-467-2655 FAX: 888-253-6695 E-Mail: amphoto@aerometric.com

# Base Station Log

### GPS OBSERVATION LOG

Station ID	<u>KLOM airport</u>	Date	<u>4 / 16 / 2015</u>
Project Number	<u>26236</u>	Julian Date	<u>106</u>
Project Name	<u>USGS DVRPC</u>	Start Time	<u>4 : 12 : 23 : AM</u>
Rcvr. Type	<u>Novatel DL-V3-L1L2</u>	Stop Time	<u>4 : 57 : 00 : PM</u>
Rcvr. S/N	<u>7-0141149</u>	Rcvr. File Name	<u>00071060.PDC</u>
Antenna Type	<u>Novatel GPS-702-66</u>	Observer	<u>Dan Rolfes</u>
Antenna S/N	<u>NAE12110034</u>		

New or Existing  
 Mon.  New  
 Existing  
 Photo Taken:  
 Yes  No  
 Monument Type:  
 Spike  PK Nail  
 AM Washer  
 Other

Height Readings:  
 (Top of Monument to Bottom of Ground Plane)

Start	2 M.		Ft.
Stop	2 M.		Ft.
Mean	2 M.		Ft.

Monument Sketch and Notes:

**Apr 16, 2015-B  
(N22GE, SN8239)**

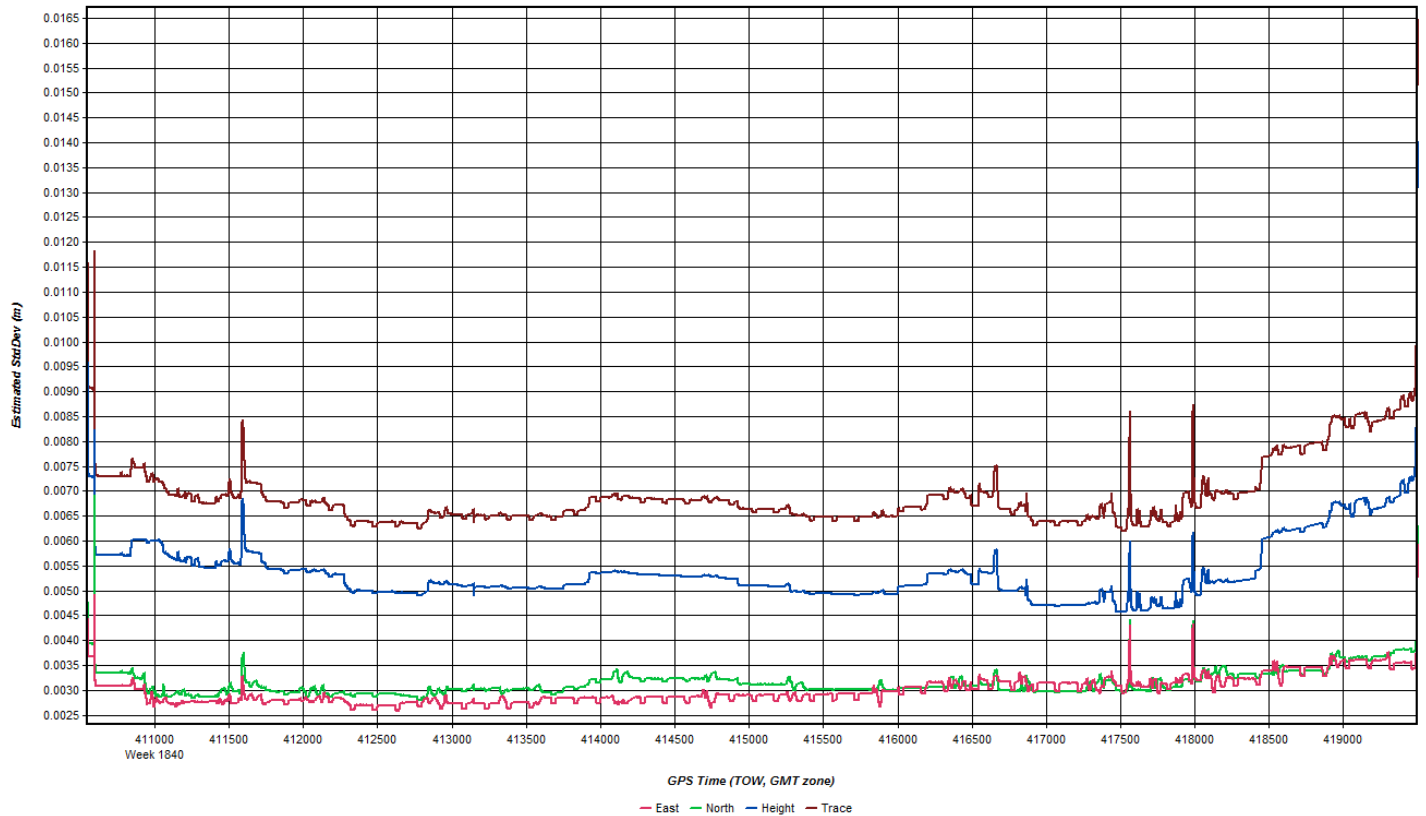
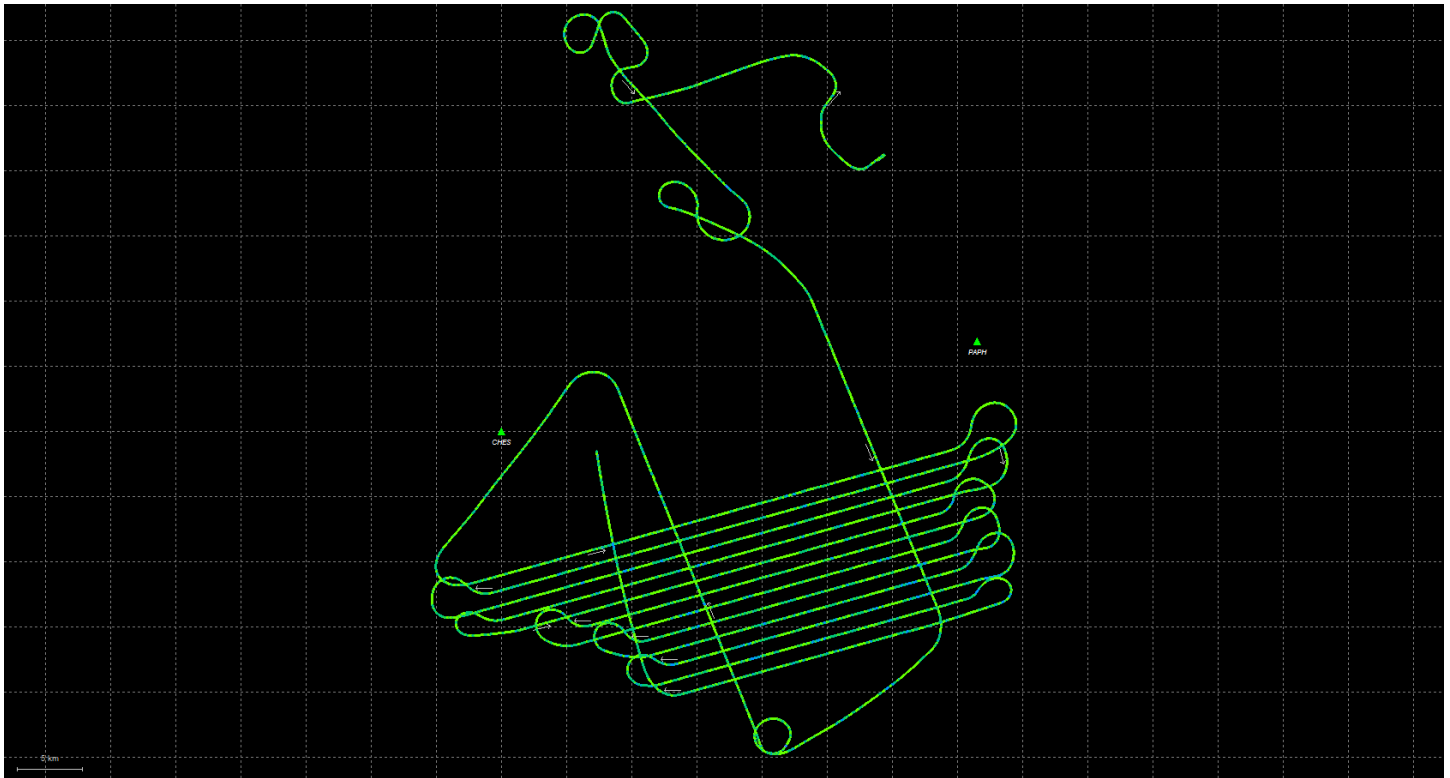



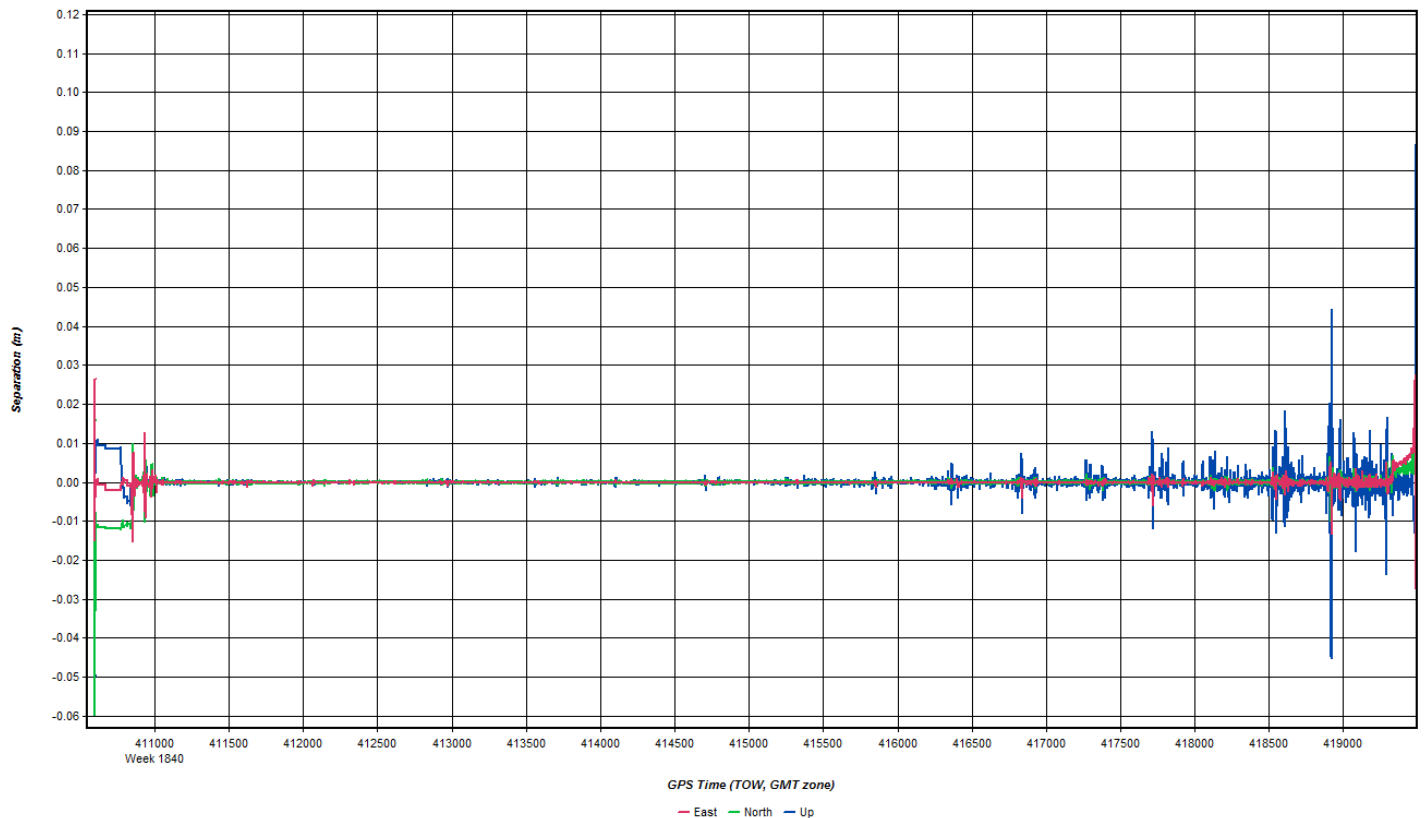
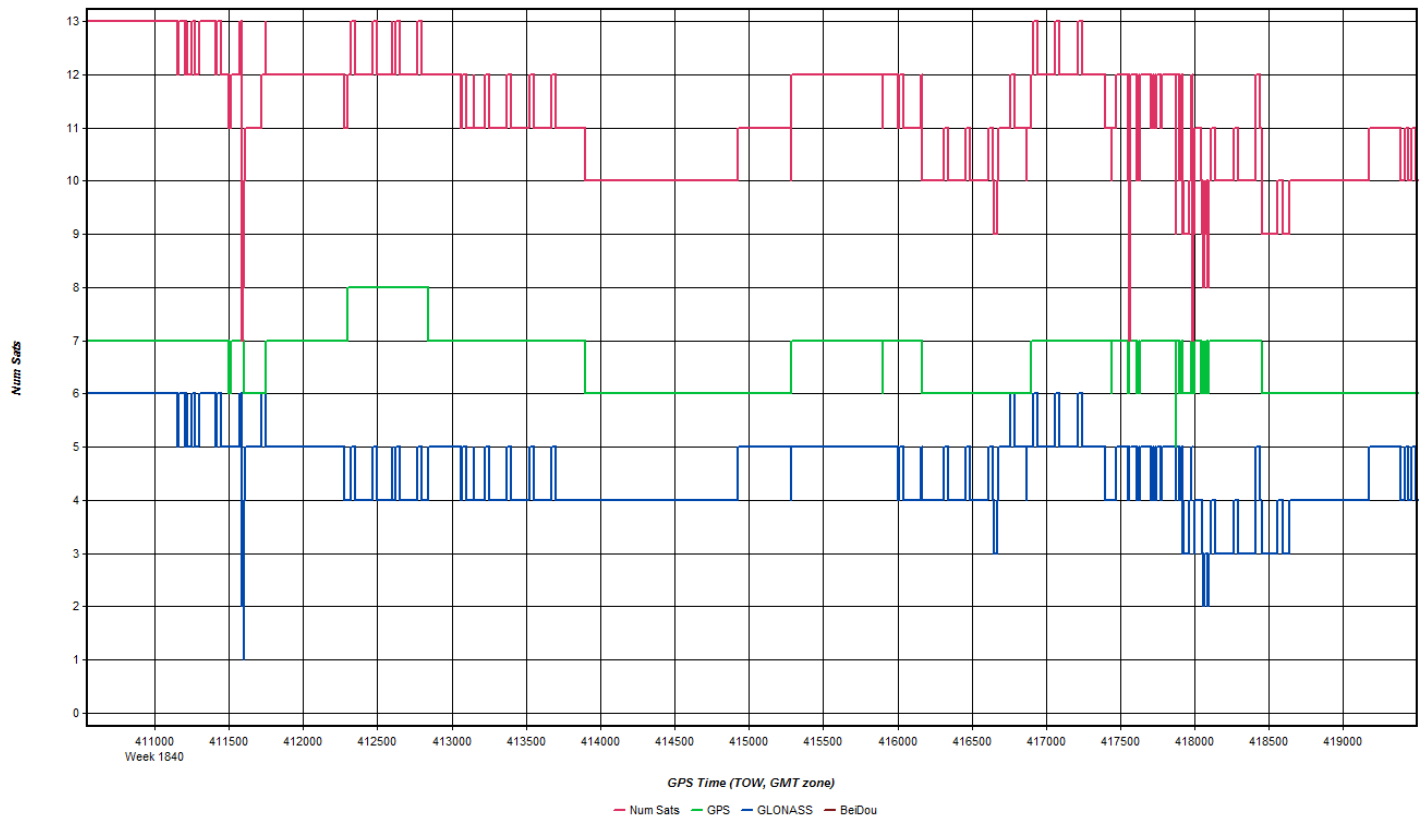

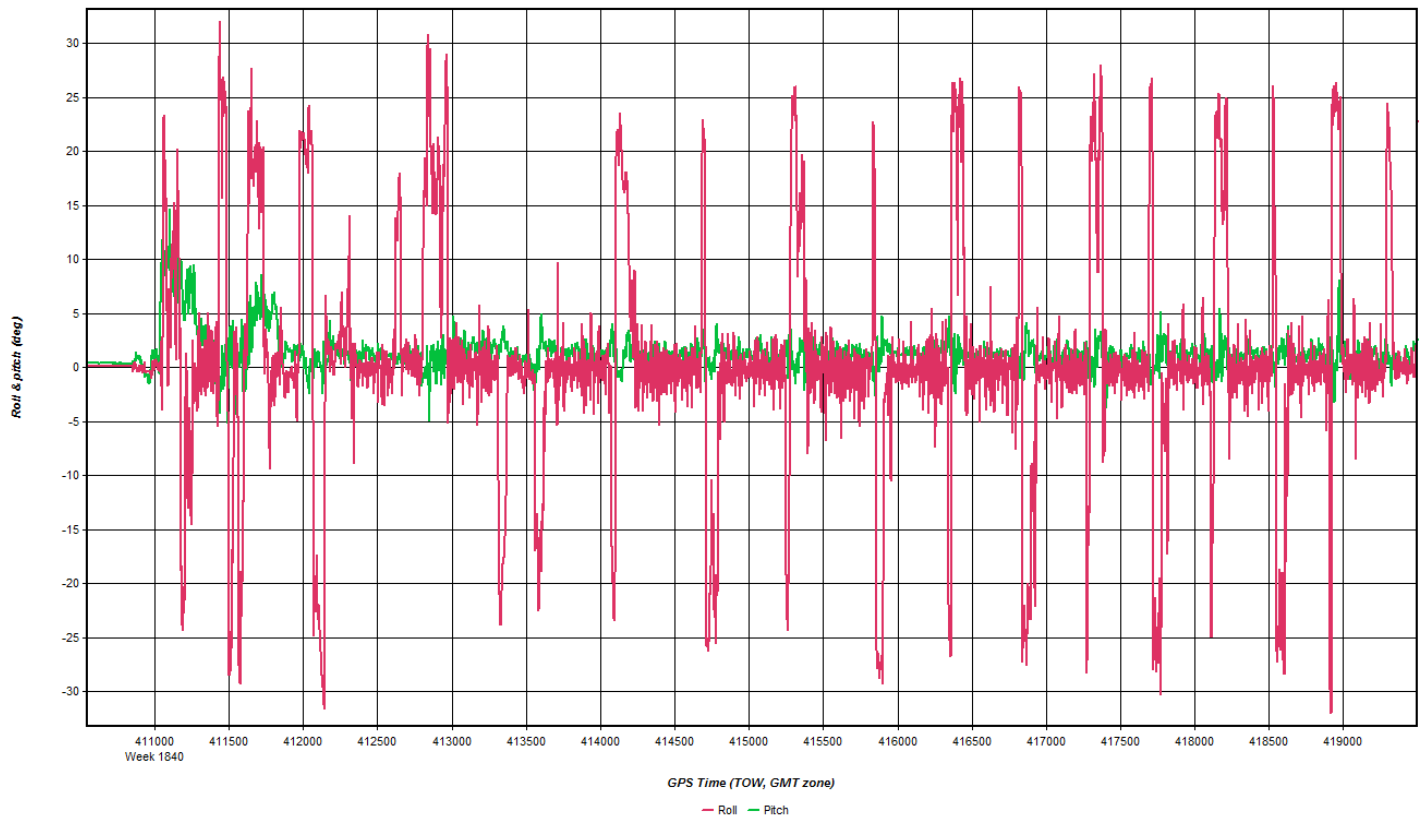
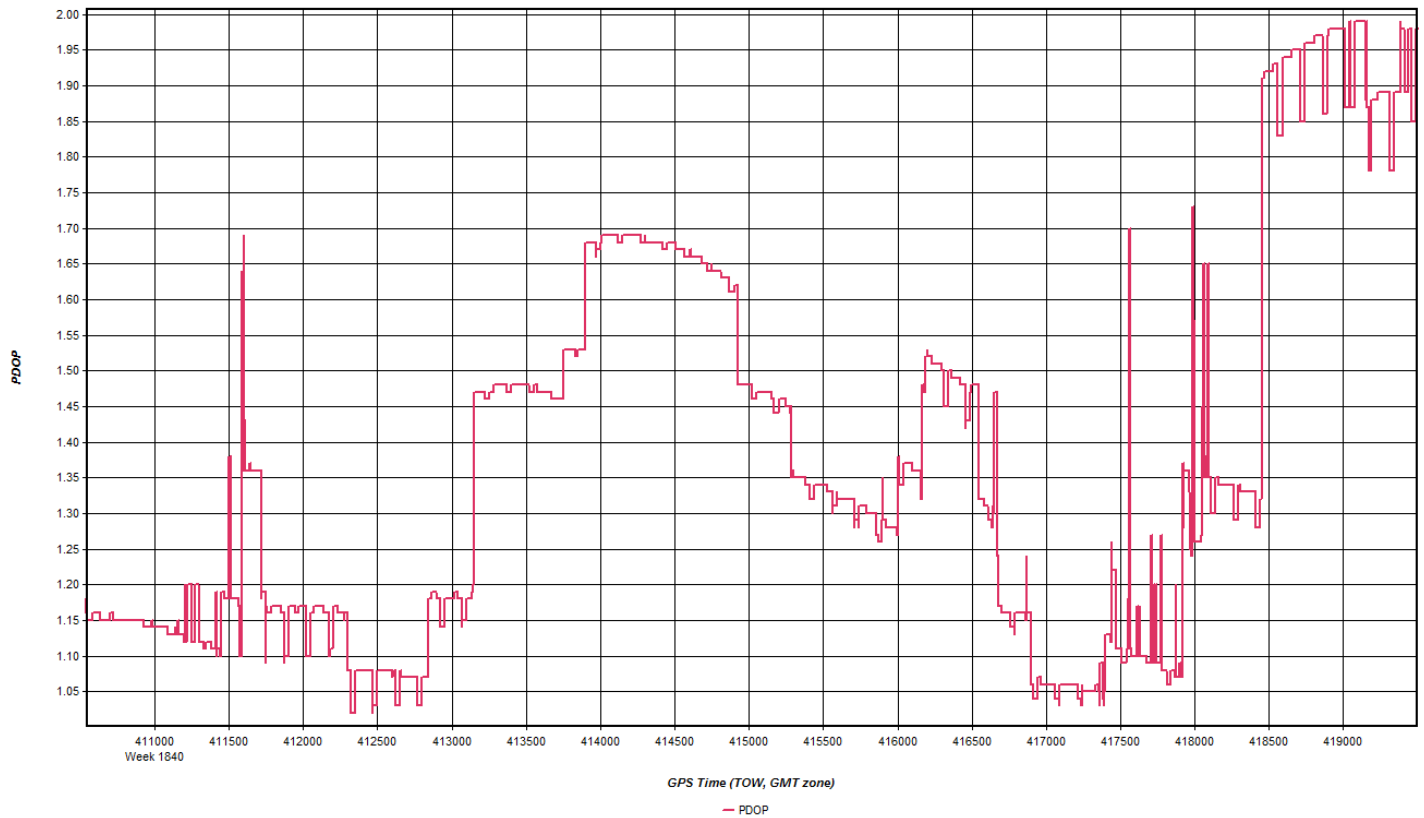

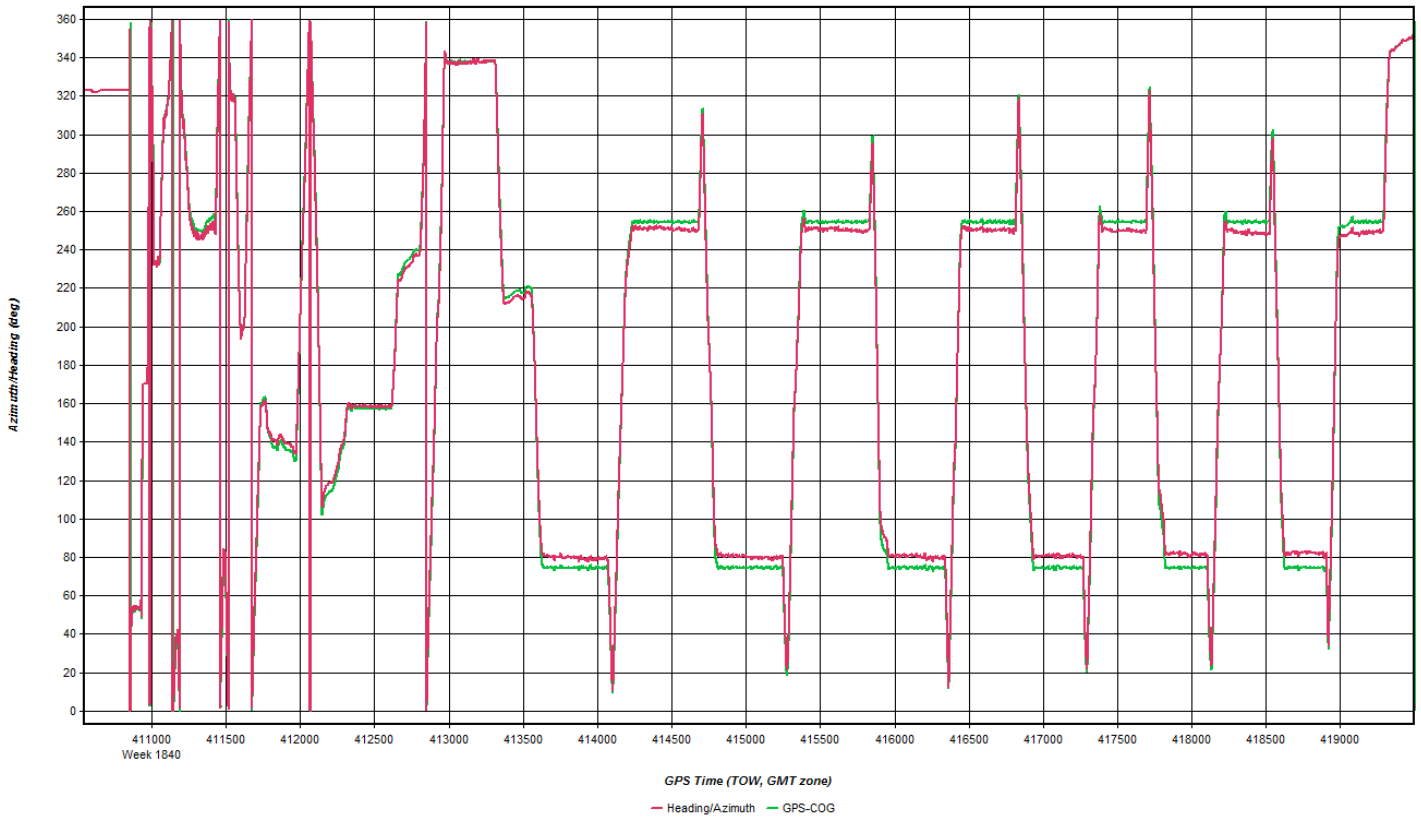

**Coordinate/Antenna Settings**

Master Remote

Base Station  
 1: CHES Name: CHES  Disabled  
 File: D:\Proc\26236\_DVRPC\NS6R\20150416\_175937\DVRPC\_KOC

Coordinates  
 Latitude: North 39 57 05.91984   
 Longitude: West 75 36 01.15234   
 Ellipsoidal height: 109.439 m   
 Datum: NAD83(2011)

Antenna Height  
 From station file: TRM41249.00, NONE   
 Antenna profile: TRM41249.00   
 Measured height: 0.000 m  
 ARP to L1 offset: 0.056 m  
 Applied height: 0.056 m  
 Measured to:  
 ARP  
 L1 Phase Centre

Coordinate/Antenna Settings

Master Remote

Base Station  
2: PAPH Name: PAPH  Disabled  
File: D:\Proc\26236\_DVRPC\NS6R\20150416\_175937\DVRPC\_KOC

Coordinates  
Latitude: North 40 00 47.34854 Compute from PPP  
Longitude: West 75 10 34.78766 Enter Grid Values  
Ellipsoidal height: 27.809 m Enter MSL Height  
Datum: NAD83(2011) Datum Options  
Select From Favorites Add To Favorites Use Average Position

Antenna Height  
From station file: LEIAX1202GG, NONE View STA File  
Antenna profile: LEIAX1202GG Info

Measured height: 0.000 m  
ARP to L1 offset: 0.063 m  
Applied height: 0.063 m

Measured to  
 ARP  
 L1 Phase Centre  
Compute From Slant

OK Cancel

# Flight Log



8242.8 → 8246.5

OPERATORS FLIGHT LOG

MISSION: S USGS DURPC QL2		DATE: 4/16/15	LEICA ALS-70						
PILOT: Young		OPERATOR: Rolles	AIRCRAFT: N226E						
PROJECT NUMBER	LINE NO. & Hdg	FREQ Hz	SCAN ANGLE	PRF KHz	FIXED GAIN	ALT (m)	TIME START	TIME STOP	REMARKS
2623	4009 87	52	40	352	N/A	74k	15:54	16:01	
	tie 2 356	174					16:05	16:07	Figure 8 @ 16:08 Land
							16:16		Static Stop
							16:19	16:24	
STATUS	TOTAL LINES	FLOWN	LEFT	AIRCRAFT SITE	AIRCRAFT FERRY	STATIC	START	STOP	NOTES:
<input type="radio"/>	23	9	0	1.8	0.2	✓	12:22	16:24	
<input type="radio"/>	25	9	16	1.5	0.2	WAX			
<input type="radio"/>									

AERO-METRIC, INC. N 8216 Resource Drive Sheboygan Falls, WI. 53085 PHONE: 920-467-2655 FAX: 888-253-6695 E-Mail: amphoto@aerometric.com

# Apr 18, 2015-A (N262AS, SN7178)



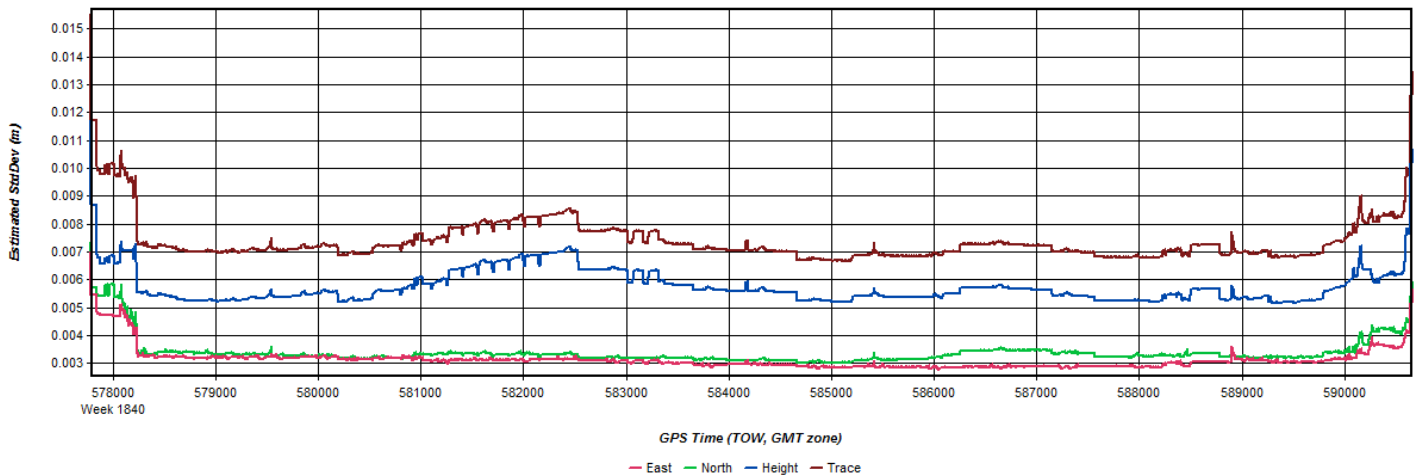
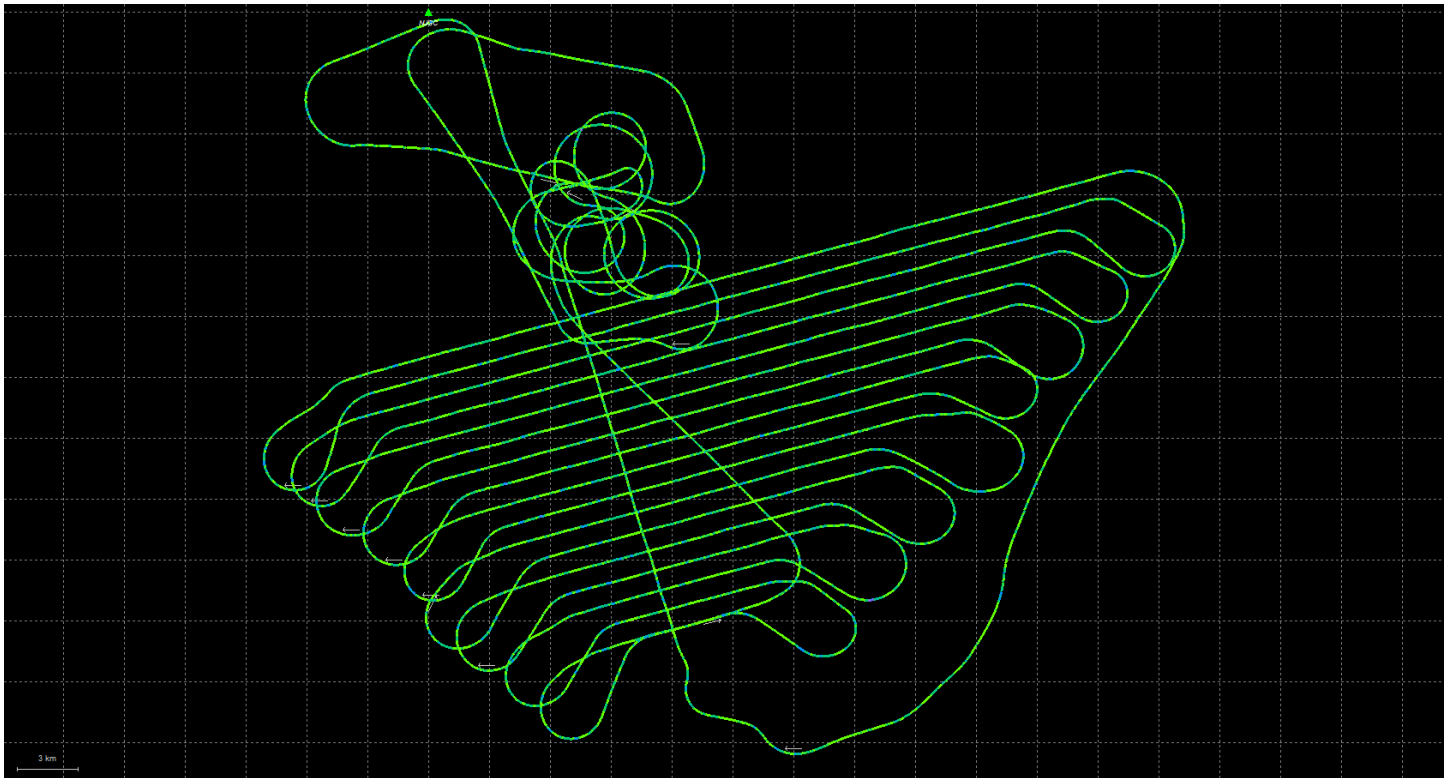

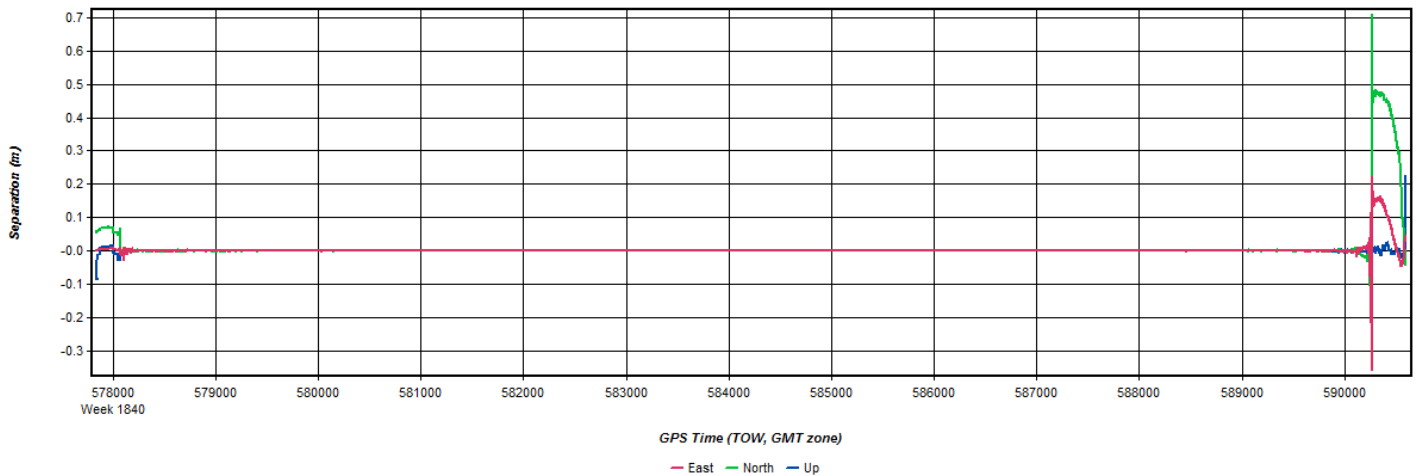
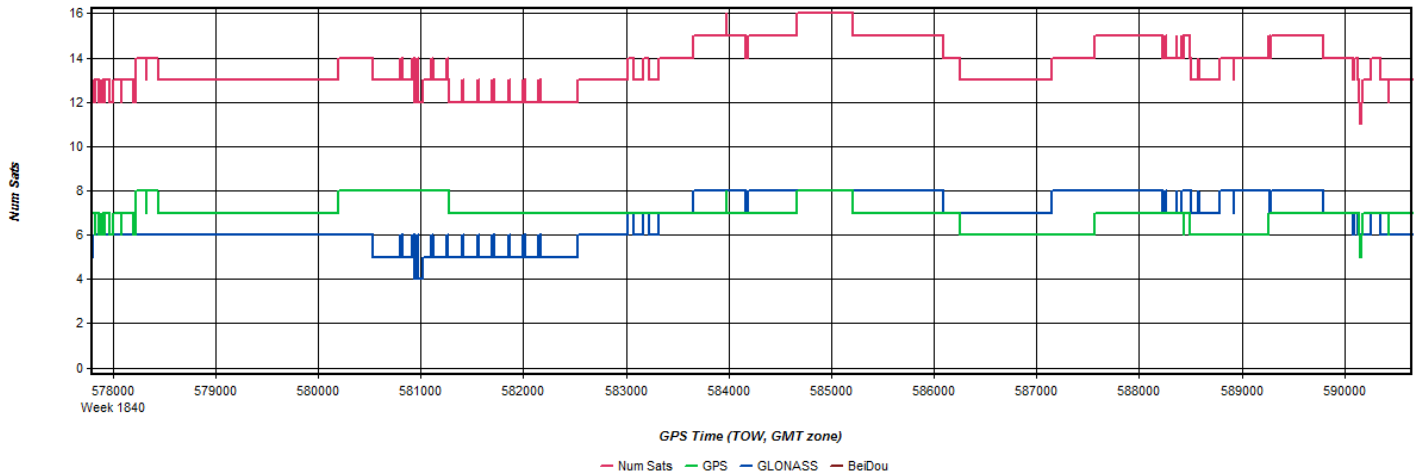

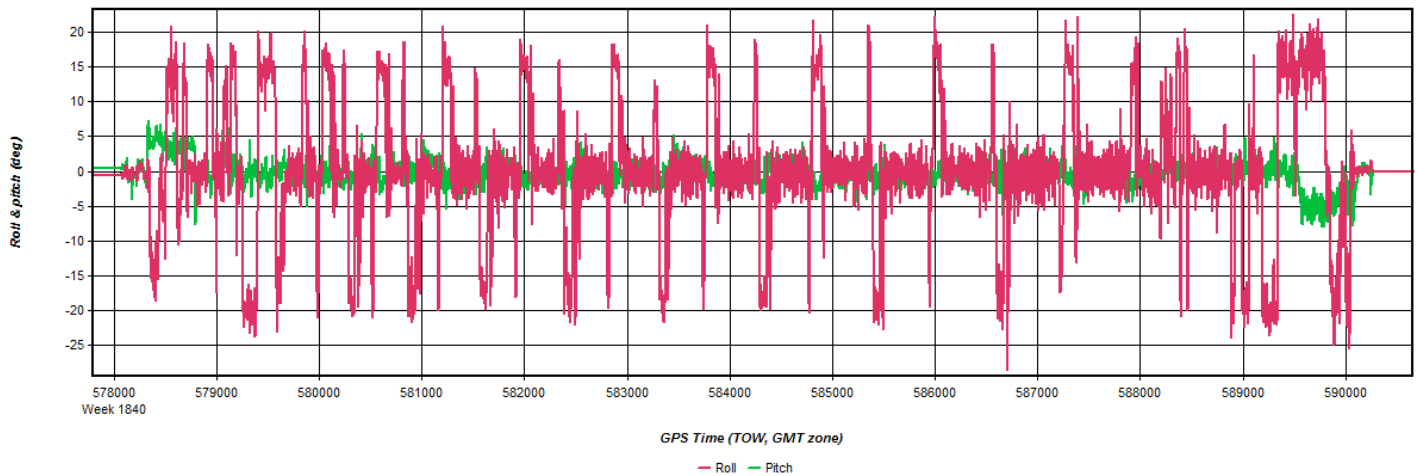
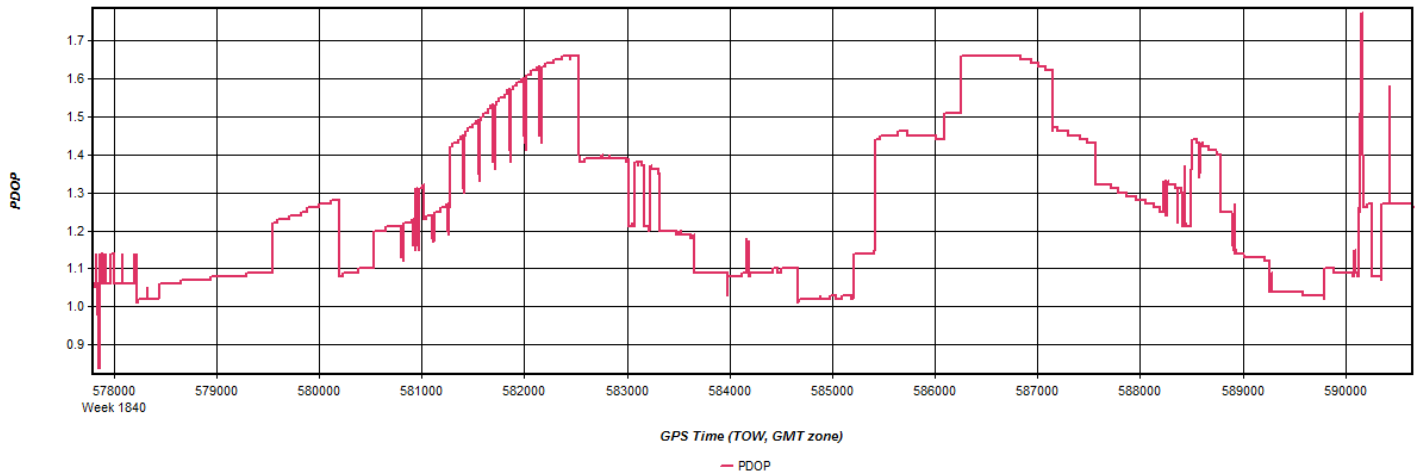

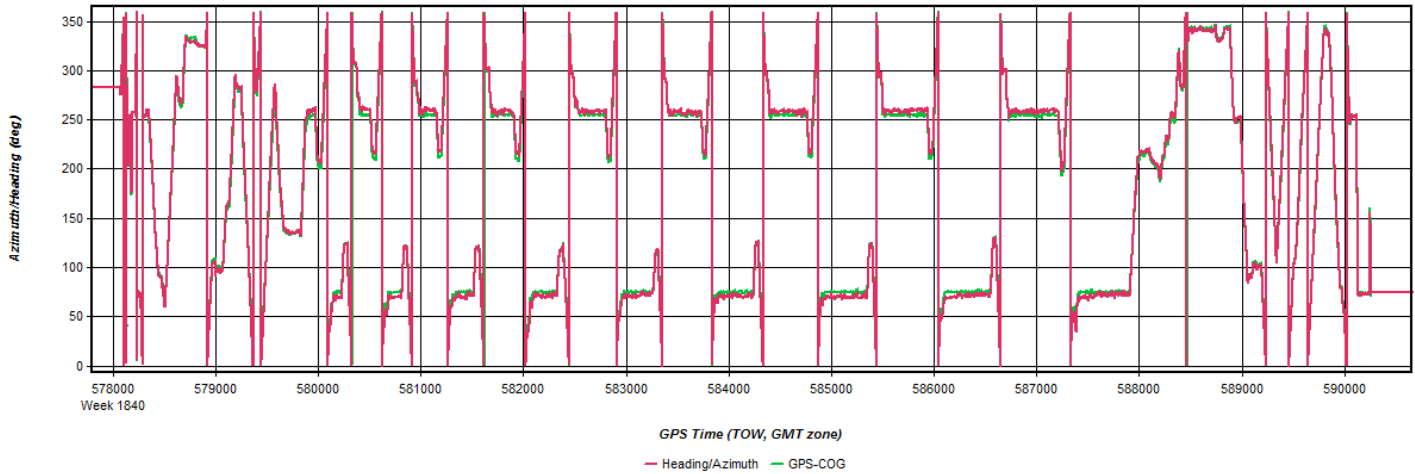

**Coordinate/Antenna Settings**

Master Remote

Base Station  
 1: NJGC Name: NJGC  Disabled  
 File: D:\Proc\26236\_DVRPC\ZAH1\26236\_20150418\20150418\_162

Coordinates  
 Latitude: North 39 46 52.79148   
 Longitude: West 75 07 11.25002   
 Ellipsoidal height: -3.994 m   
 Datum: NAD83(2011)

Antenna Height  
 From station file: LEIAR10, NONE   
 Antenna profile: LEIAR10   
 Measured height: 0.000 m  
 ARP to L1 offset: 0.089 m  
 Applied height: 0.089 m  
 Measured to:  
 ARP  
 L1 Phase Centre

# Flight Log

OPERATORS FLIGHT LOG

MISSION: S 150418  
PILOT: J Baerlin  
PROJECT NUMBER: CROSS KEYS PA

DATE: 4-18-15  
OPERATOR: M Aust  
LEICA ALS-70  
AIRCRAFT: 262AS

PROJECT NUMBER	LINE NO. & Hdg	GND SPEED (KTS)	FREQ Hz	SCAN ANGLE	PRF KHZ	FIXED GAIN	ALT (m)	TIME		REMARKS
								START	STOP	
	7043 255°	152	53	40	273	255	6500'	1705		CHOPPY
	7043 75°	143					6500'	1709	1714	ABORT-REFLY
	7042 255°	140					6470'	1718	1719	REFLIGHT
	7041 75°	146					6485'	1723	1725	
	7040 255°	157					6540'	1728	1731	
	7039 75°	150					6570'	1735	1738	
	7038 255°	150					6540'	1741	1745	
	7037 75°	150					6540'	1749	1753	
	7036 255°	153					6485'	1752	1759	
	7035 75°	147					6470'	1803	1808	
	7034 255°	150					6525'	1811	1816	
	7033 75°	156					6575'	1820	1825	
	7032 255°	147					6490'	1829	1835	
	7031 75°	152					6480'	1838	1845	
	7030 255°	157					6530'	1848	1855	
	7029 75°	136					6450'	1858	1906	
	7028 255°	150					6580'	1909	1918	
	7027 75°	140					6415'	1927	1932	
	7044 303°	15	31	17N	n/a		5min	12:15	4:00	CROSSFLIGHT - END LIFT NOTES: ABORT - TURNED FOR TRAFFIC
STATUS	TOTAL LINES	46								PAGE 1 of 1

Scanned by CamScanner

AERO-METRIC, INC. N.6216 Resource Drive Sheboygan Falls, WI. 53085 PHONE: 920-467-2655 FAX: 888-253-6655 E-Mail: amphoto@aerometric.com

**Apr 18, 2015-A  
(N22GE, SN8239)**

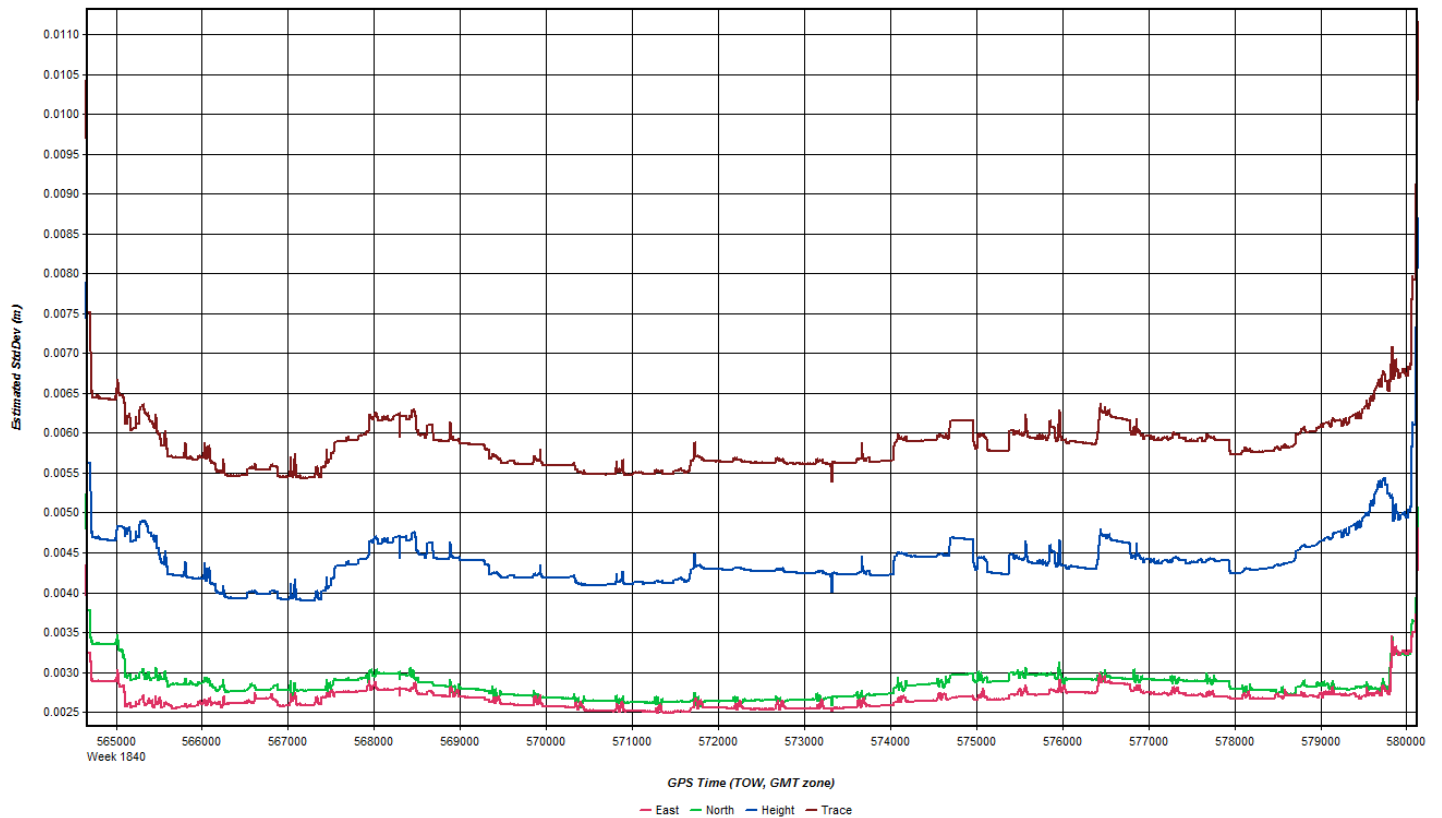
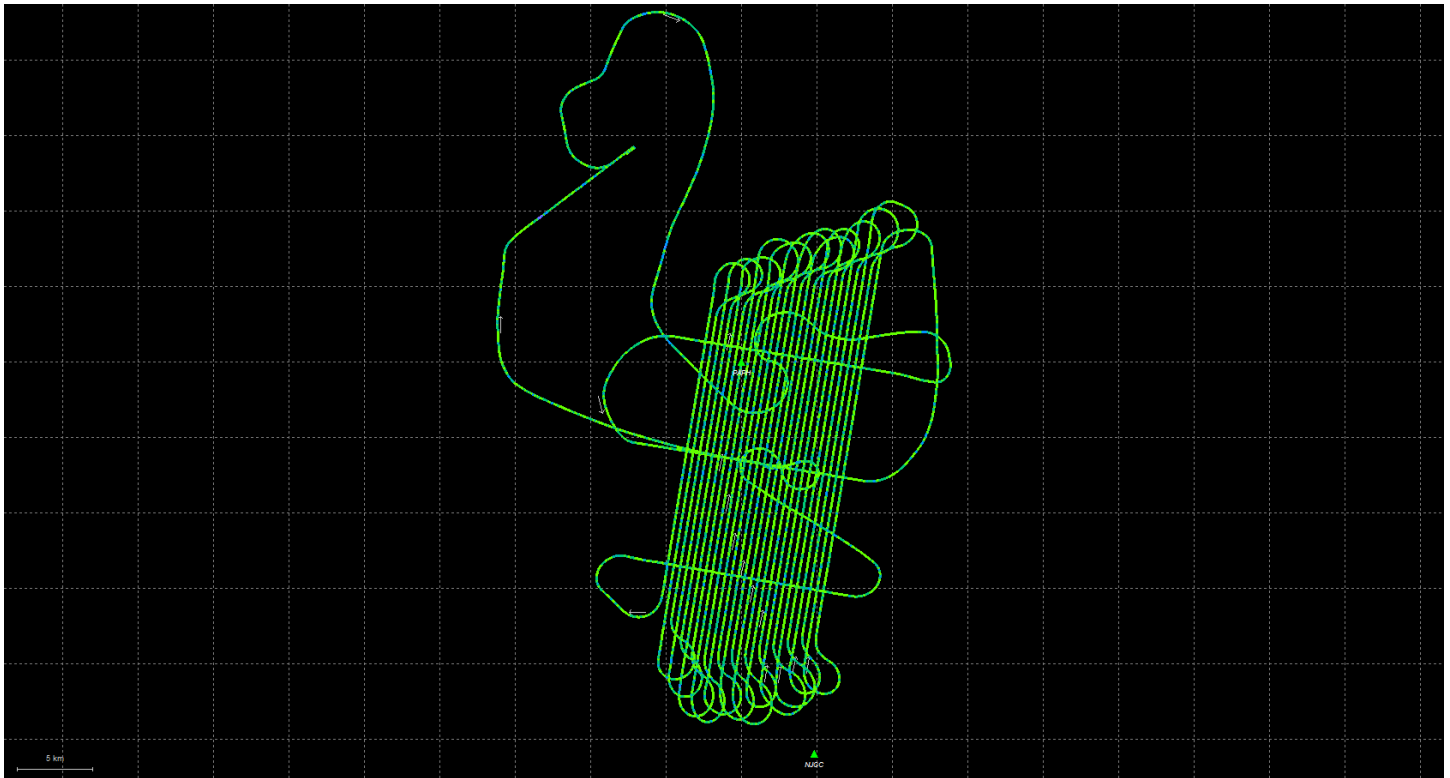



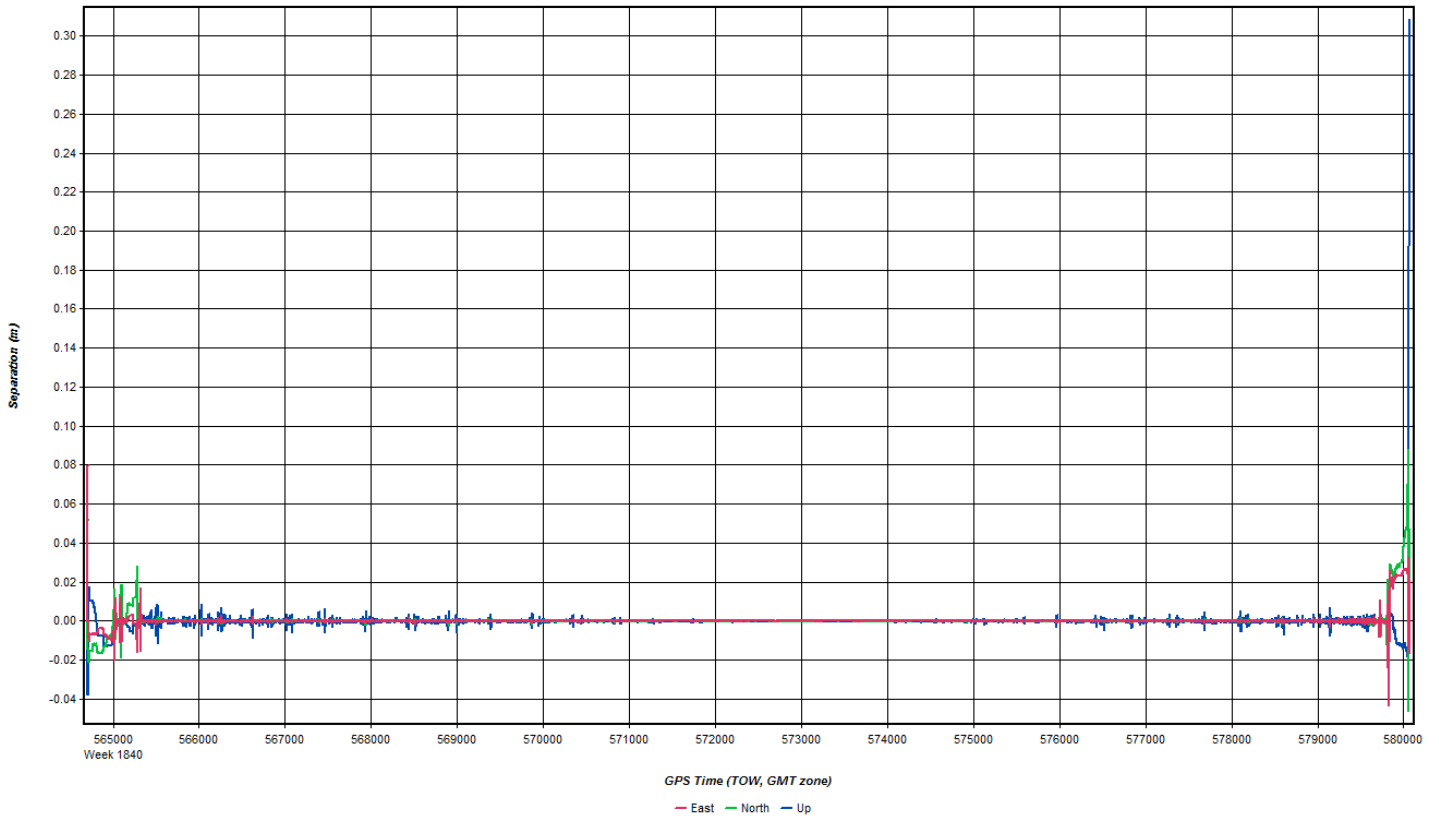
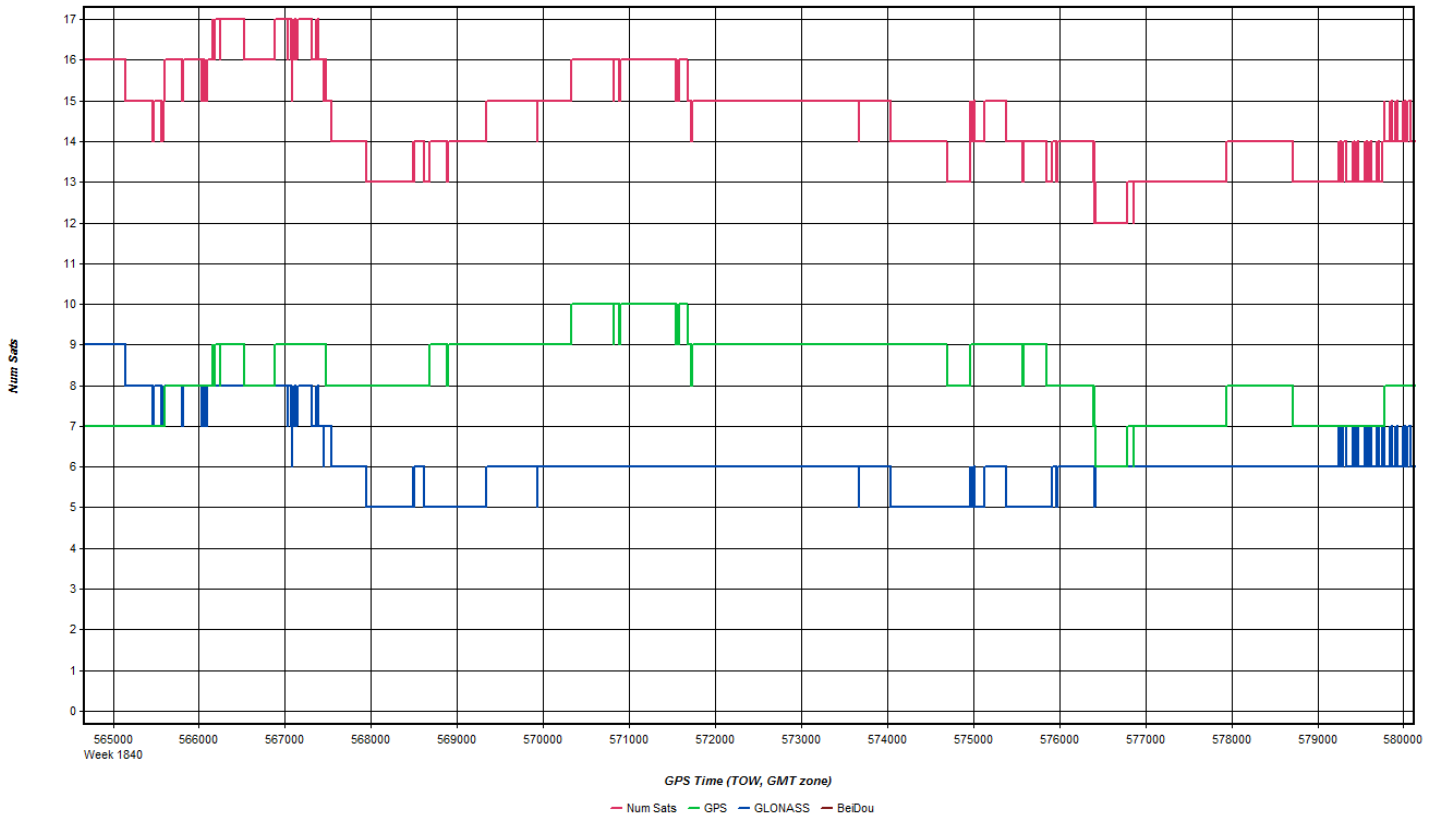

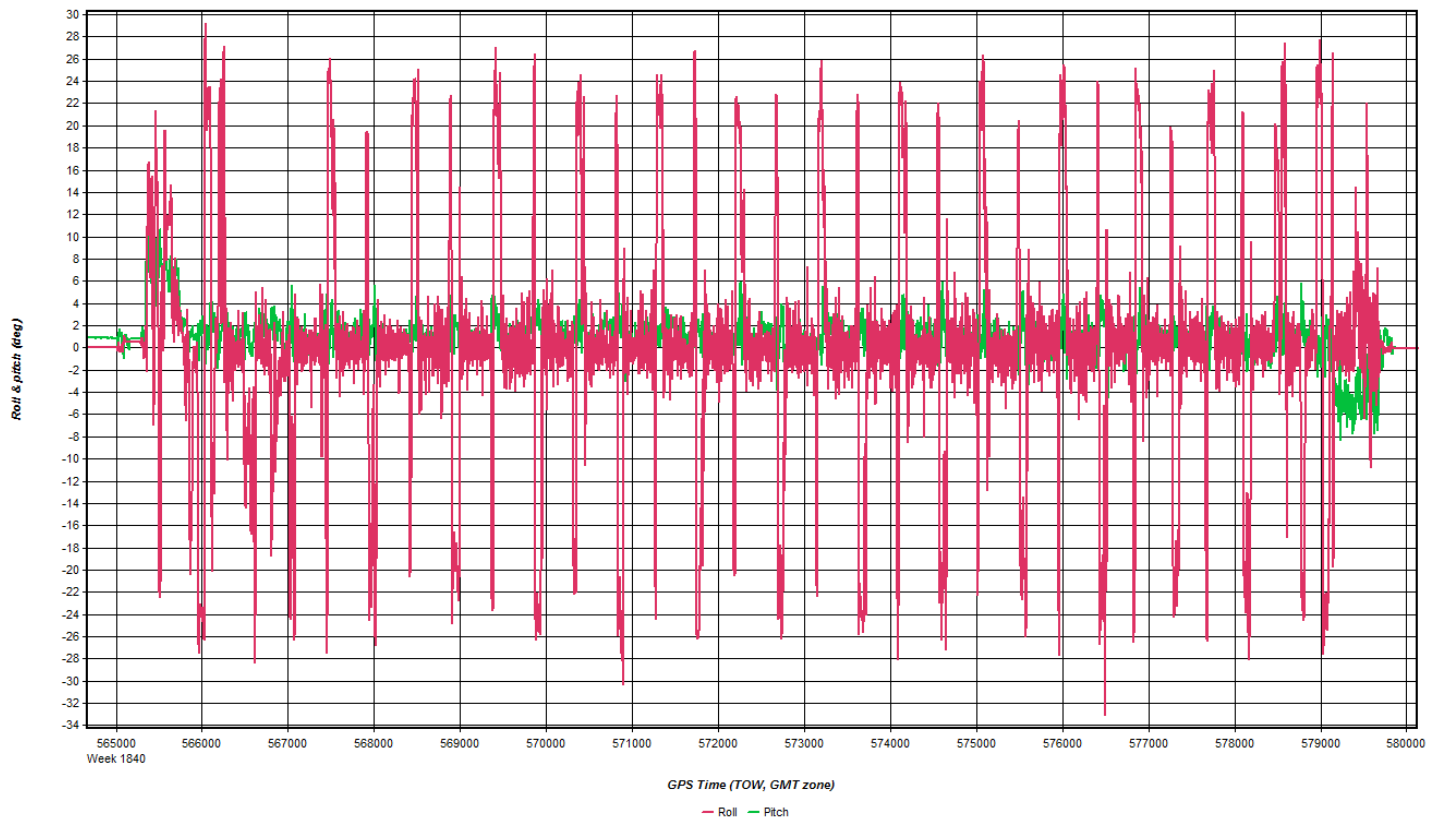
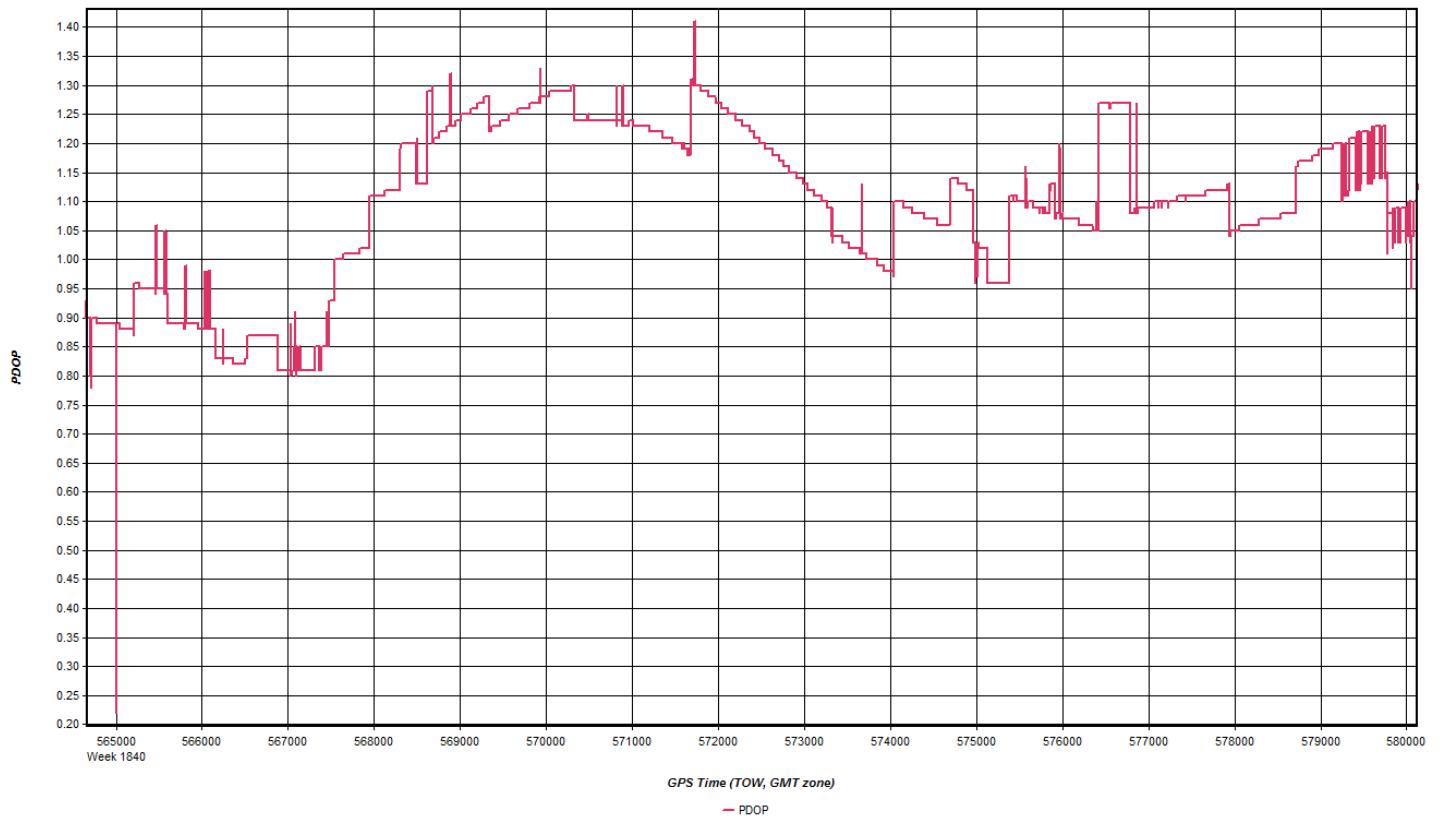

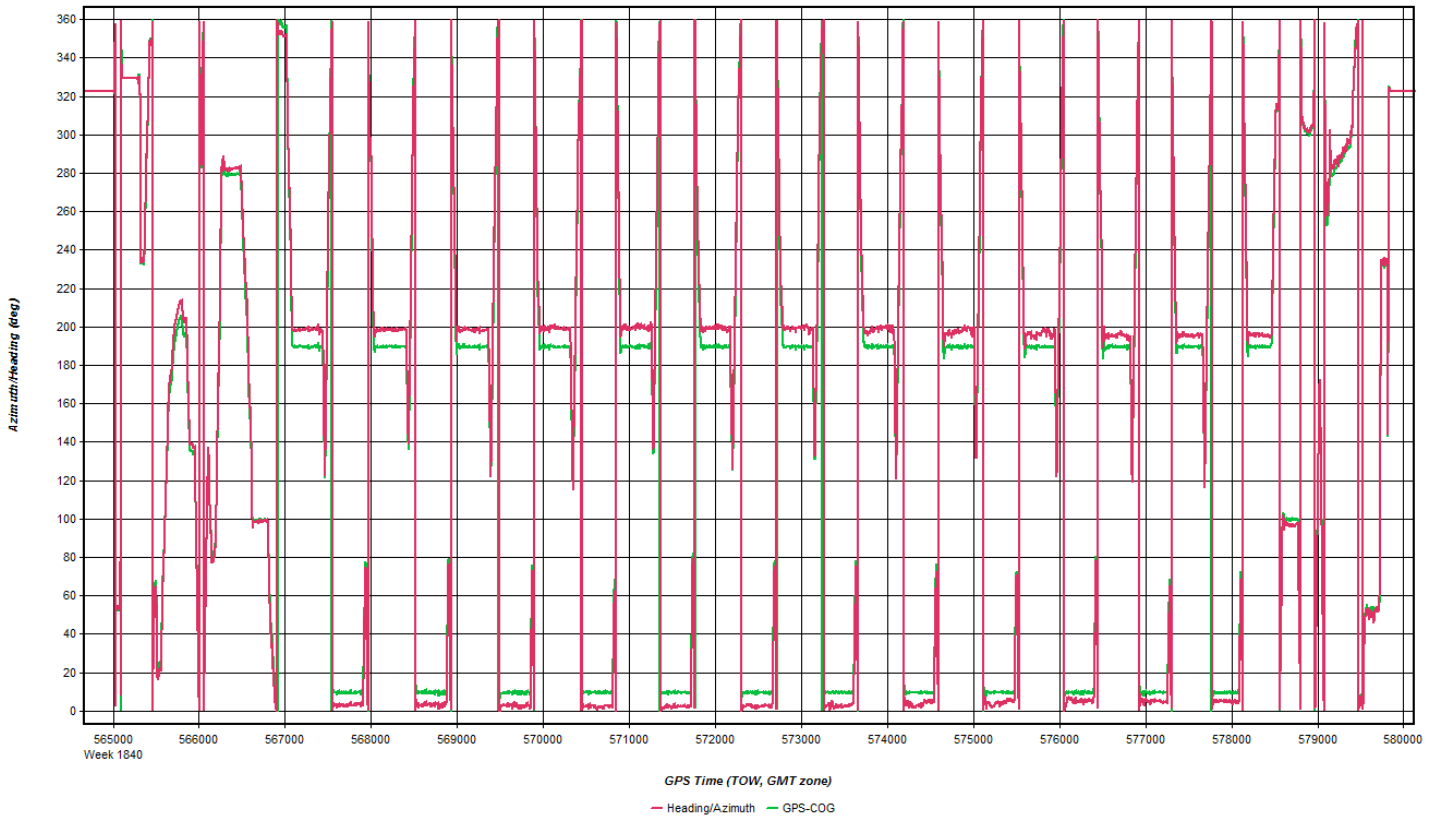

**Coordinate/Antenna Settings**

Master Remote

Base Station  
 2: NJGC Name: NJGC  Disabled  
 File: D:\Proc\26236\_DVRPC\NS6R\20150418\_124900\DVRPC\_KVA

Coordinates  
 Latitude: North 39 46 52.79148   
 Longitude: West 75 07 11.25002   
 Ellipsoidal height: -3.994 m   
 Datum: NAD83(2011)

Antenna Height  
 From station file: LEIAR10, NONE   
 Antenna profile: LEIAR10   
 Measured height: 0.000 m  
 ARP to L1 offset: 0.089 m  
 Applied height: 0.089 m  
 Measured to:  
 ARP  
 L1 Phase Centre

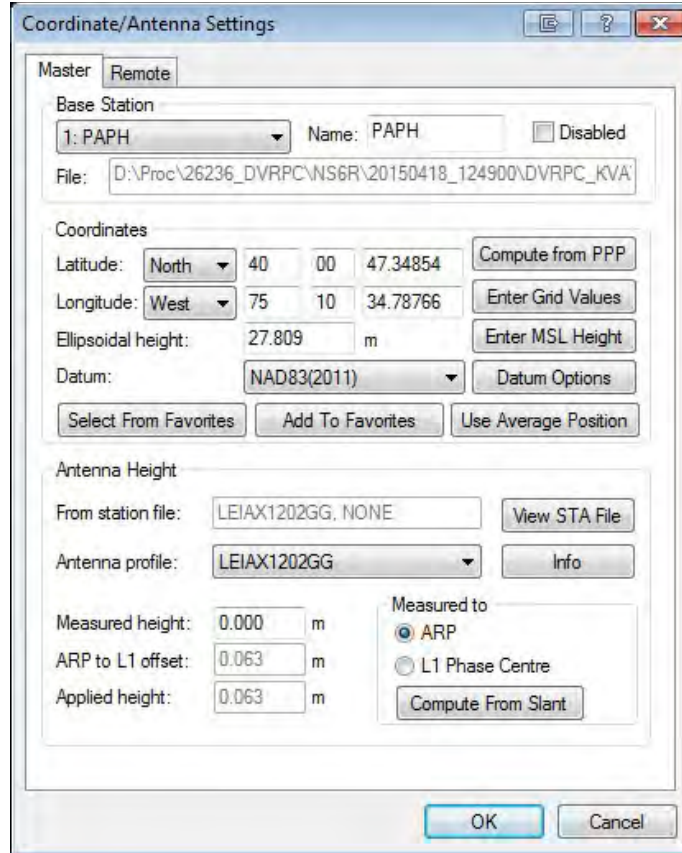

Coordinate/Antenna Settings

Master Remote

Base Station

1: PAPH Name: PAPH  Disabled

File: D:\Proc\26236\_DVRPC\NS6R\20150418\_124900\DVRPC\_KVA

Coordinates

Latitude: North 40 00 47.34854

Longitude: West 75 10 34.78766

Ellipsoidal height: 27.809 m

Datum: NAD83(2011)

Antenna Height

From station file: LEIAX1202GG, NONE

Antenna profile: LEIAX1202GG

Measured height: 0.000 m

ARP to L1 offset: 0.063 m

Applied height: 0.063 m

Measured to

ARP

L1 Phase Centre

# Flight Log

8249.1 → 8253.1  
OPERATORS FLIGHT LOG

MISSION: S USGS DVRPC RL2		DATE: 4/18/15		LEICA ALS-70						
PILOT: Young		OPERATOR: R. Oles		AIRCRAFT: N226E						
PROJECT NUMBER	LINE NO. & Hdg	GND SPEED (KTS)	FREQ Hz	SCAN ANGLE	PRF KHZ	FIXED GAIN	ALT (m)	TIME START	TIME STOP	REMARKS
26236								12:51	12:56	Static Start
								13:02		T/O
	5027 292	152	<del>52</del>	40	352	N/A	7.4K	13:18	13:21	Figure 8 @ 13:12
	5026 112	154	52	40	362	N/A	7.4K	13:23	13:26	
	5025 202	140	48	28	366	N/A	7.4K	13:31	13:37	
	5024 22	143						13:39	13:44	
	5023 202	140						13:47	13:53	
	5022 22	142						13:55	14:01	
	5021 202	139						14:03	14:09	
	5020 22	139						14:11	14:17	
	5019 202	141						14:19	14:25	
	5018 22	138						14:27	14:33	
	5017 202	145						14:35	14:40	
	5016 22	140						14:43	14:48	
	5015 202	144						14:50	14:56	
	5014 22	146						14:58	15:04	
	5013 202	140						15:06	15:12	
	5012 22	138						15:14	15:20	
	5011 202	142						15:22	15:27	
	TOTAL LINES	FLOWN	LEFT	SITE	AIRCRAFT FERRY	STATIC		START	STOP	NOTES:
○	26236	28	0	3.5	0.5	✓		12:51	17:08	
○						WIX				
○										

AERO-METRIC, INC. N.6216 Resource Drive Sheboygan Falls, WI. 53085 PHONE: 920-467-2655 FAX: 888-253-6695 E-Mail: amphoto@aerometric.com



# Base Station Log





**Station Occupation Report  
For Airborne GPS**

Project: USGS DELAWARE VALLEY

Location: 17N

Project Number: 26236

Completed by: M Aust

Date: 4-18-15

Receiver: TRIMBLE R7

Receiver Type: \_\_\_\_\_

Antenna Type: \_\_\_\_\_

Station ID: SET POINT

Start -- H.I. (m): 2 m

End -- H.I. (m): 2 m

H.I. (ft): \_\_\_\_\_

Start Time: 12:00

End Time: 4:15

Time Zone: EST

Operator: M Aust



Comments: SET POINT

\_\_\_\_\_  
\_\_\_\_\_  
\_\_\_\_\_  
\_\_\_\_\_  
\_\_\_\_\_  
\_\_\_\_\_

# Apr 19, 2015-A (N262AS, SN7178)

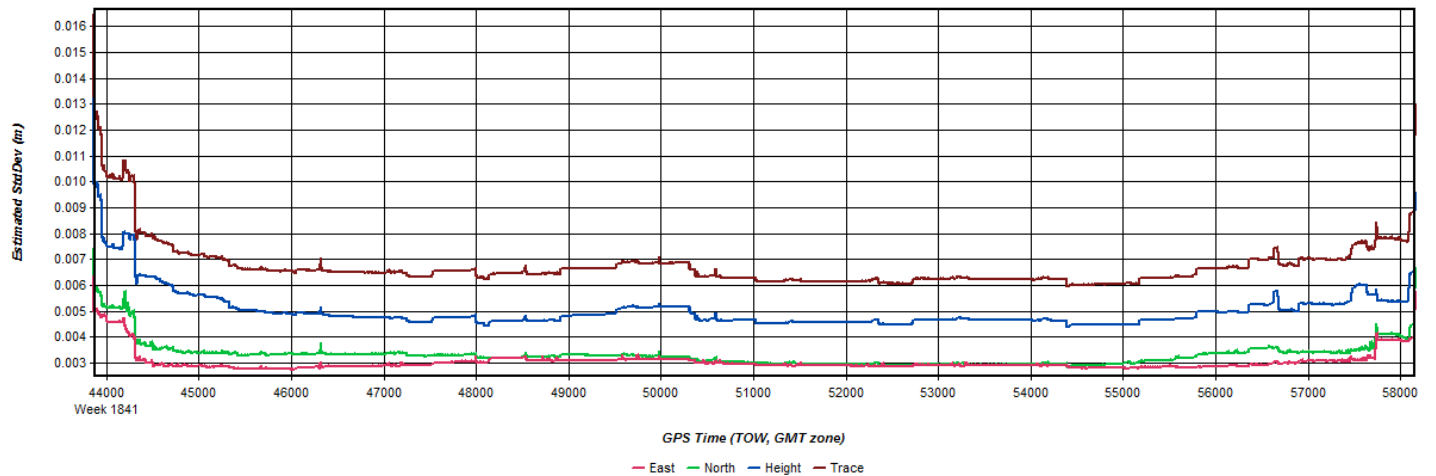
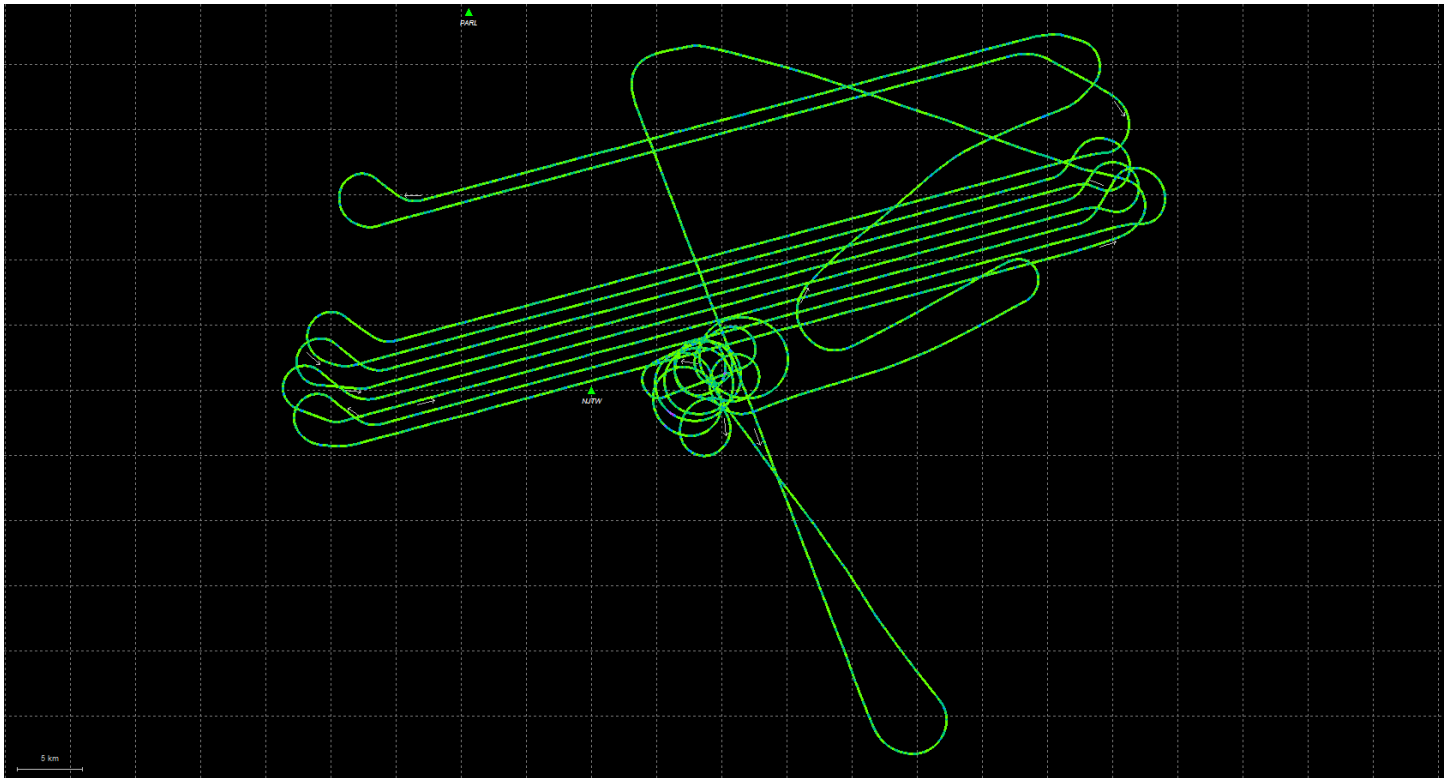

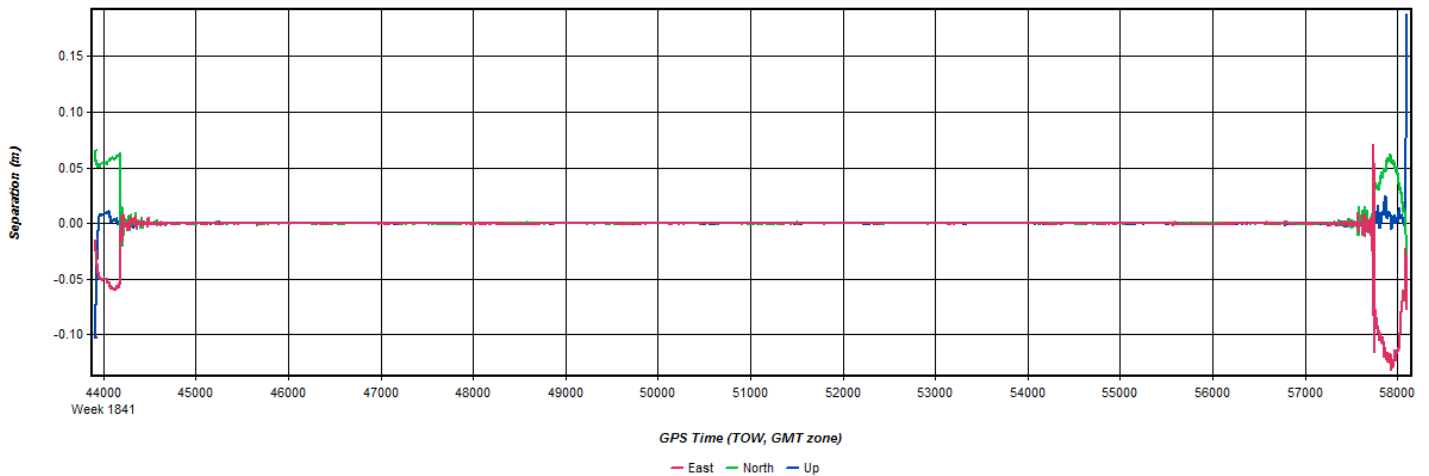
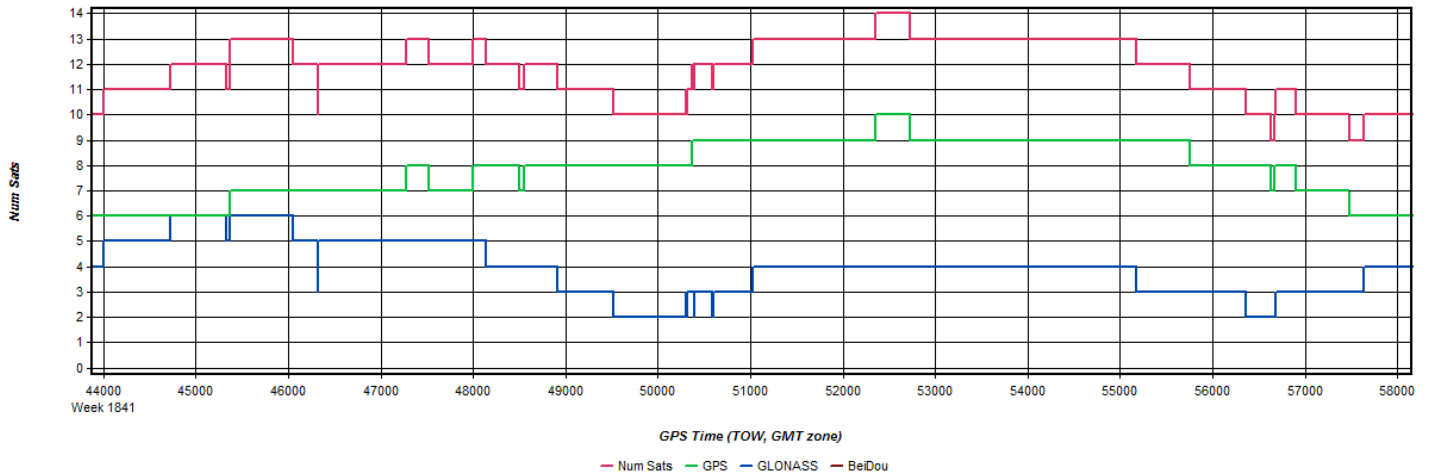

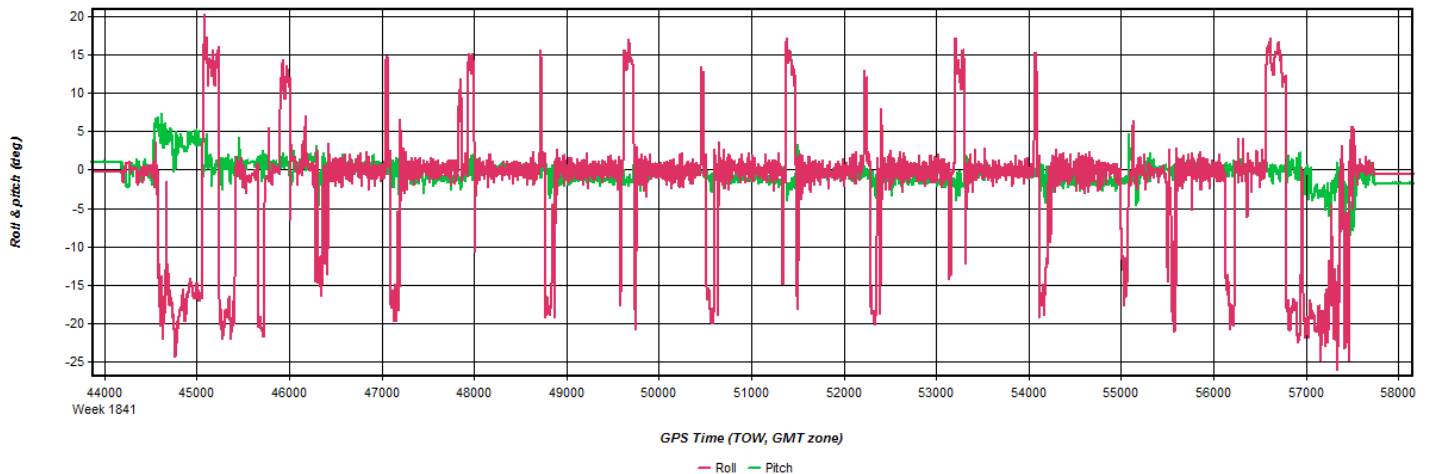
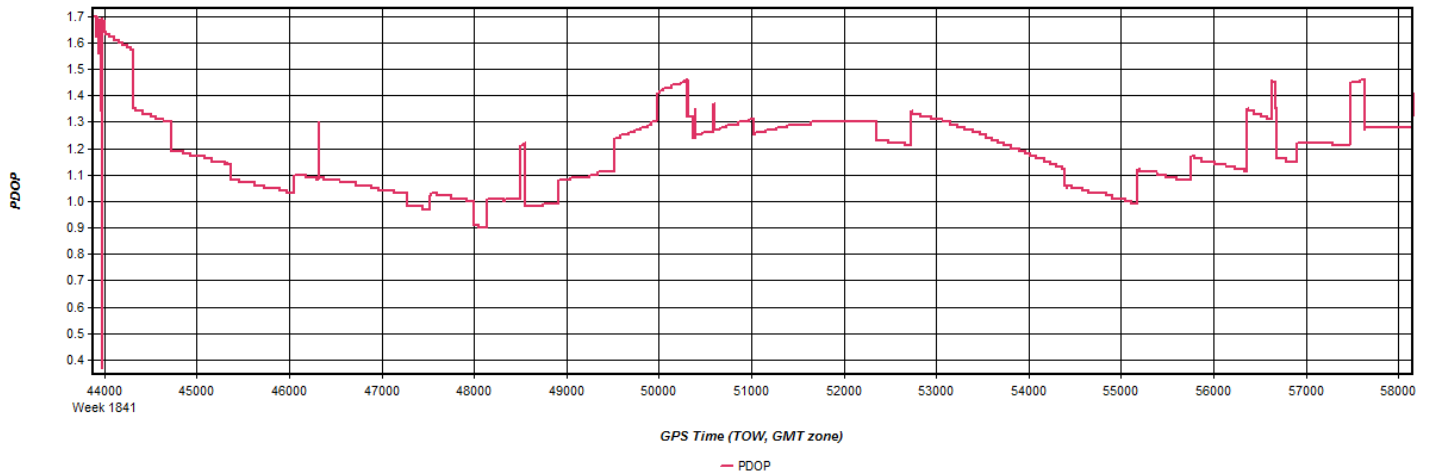

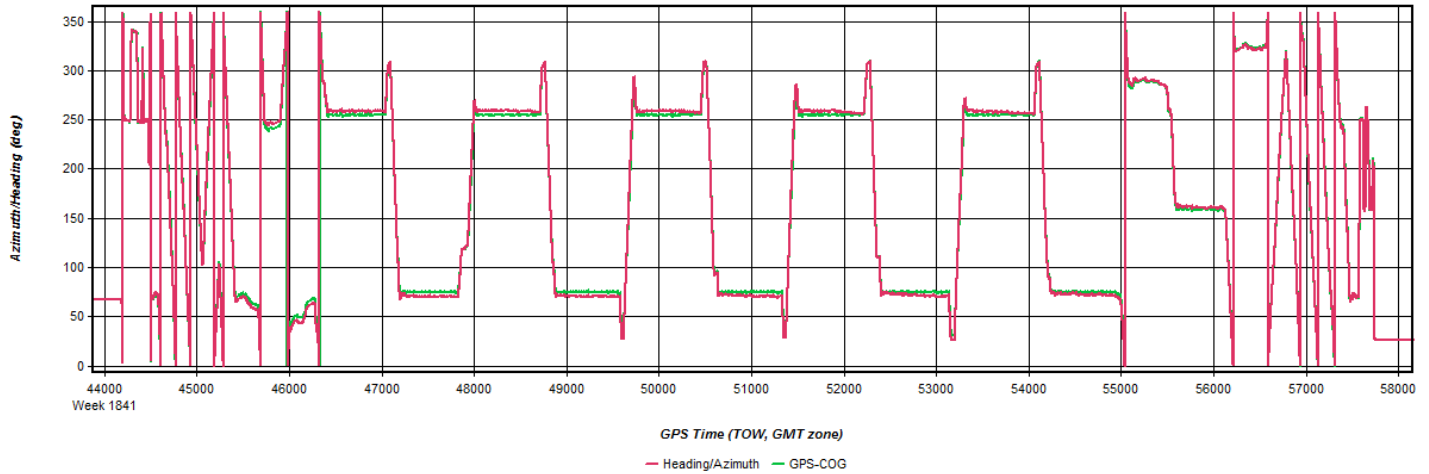

Coordinate/Antenna Settings

Master Remote

Base Station  
 1: NJTW Name: NJTW  Disabled  
 File: D:\Proc\26236\_DVRPC\ZAH1\26236\_20150419\Lift\_A\2015041

Coordinates  
 Latitude: North 39 56 11.04331   
 Longitude: West 74 56 58.71204   
 Ellipsoidal height: -20.002 m   
 Datum: NAD83(2011)

Antenna Height  
 From station file: TRM41249.00, NONE   
 Antenna profile: TRM41249.00   
 Measured height: 0.046 m  
 ARP to L1 offset: 0.056 m  
 Applied height: 0.102 m  
 Measured to:  
 ARP  
 L1 Phase Centre

Coordinate/Antenna Settings

Master Remote

Base Station  
2: PARL Name: PARL  Disabled  
File: D:\Proc\26236\_DVRPC\ZAH1\26236\_20150419\Lifit\_A\2015041

Coordinates  
Latitude: North 40 11 46.22401 Compute from PPP  
Longitude: West 75 03 35.66418 Enter Grid Values  
Ellipsoidal height: 76.548 m Enter MSL Height  
Datum: NAD83(2011) Datum Options  
Select From Favorites Add To Favorites Use Average Position

Antenna Height  
From station file: TRM57971.00, NONE View STA File  
Antenna profile: TRM57971.00 Info  
Measured height: 0.000 m  
ARP to L1 offset: 0.067 m  
Applied height: 0.067 m  
Measured to  
 ARP  
 L1 Phase Centre  
Compute From Slant

OK Cancel

# Flight Log



Scanned by CamScanner

OPERATORS FLIGHT LOG										
MISSION: S 150419-120836			DATE: 4-19-15			LEICA ALS-70				
PILOT: J BARHAM			OPERATOR: M Aust			AIRCRAFT: 262AS				
PROJECT NUMBER	LINE NO. & Hdg	GND SPEED (KTS)	FREQ Hz	SCAN ANGLE	PRF KHz	FIXED GAIN	ALT (m)	TIME START	TIME STOP	REMARKS
26236	6001		53	40	273	255				
USGS	<del>6001</del> 255°	149					6340'	12:54	1303	SMOOTH
DELAWARE	6002 75°	152					6350'	1307	1317	
VALLEY	6011 255°	154					6400'	1320	1331	CLEARED INTO RESTRICTED AREA
	6012 75°	149					6420'	1335	1345	
	6013 255°	152					6360'	1349	1400	
	6014 75°	157					6310'	1404	1415	
	6015 255°	147					6390'	1418	1429	
	6016 75°	153					6450'	1433	1445	
	6017 255°	154					6430'	1449	1500	
	6018 75°	154					6440'	1504	1575	
	6048 159°	181					8380'	1526	1535	XXXXXXXXXX CROSSFLIGHT- END LIET A
	6019 75°	152					6410'	1756	1808	BEGIN LIET B
	6020 255°	155					6470'	1811	1823	150419-172024
	6021 75°	152					6430'	1827	1839	
	6022 255°	149					6420'	1843	1855	
	6023 75°	153					6460'	1859	1911	
	6024 255°	155					6440'	1915	1926	
STATUS	TOTAL LINES	FLOWN	LEFT	SITE	AIRCRAFT	FERRY	STATIC	START	STOP	NOTES: PAGE
○	48	10	38	KVA4	15 MIN		5 MIN	8:15	12:10	← LIET A
○	48	10	28	KVA4	n/a		W/ CLEAR WITH A LITTLE HAZE			1:10p START- 5:00 STOP - LIET B
○										

AERO-METRIC, INC. N.6216 Resource Drive Sheboygan Falls, WI. 53085 PHONE: 920-487-2655 FAX: 888-253-6695 E-Mail: amphoto@aerometric.com

**Apr 19, 2015-B  
(N262AS, SN7178)**

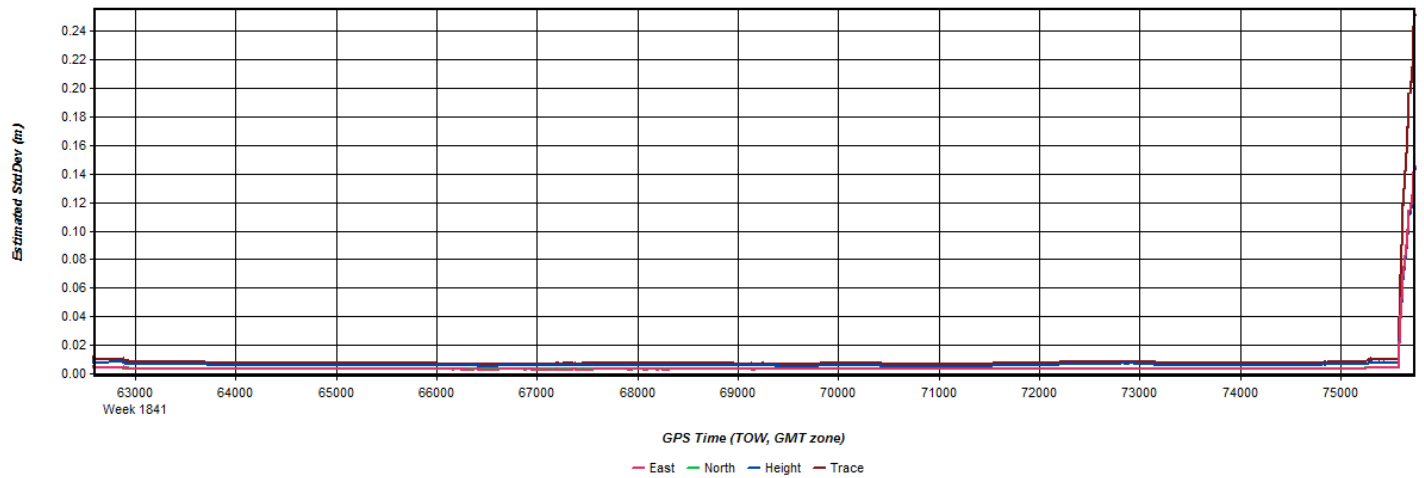
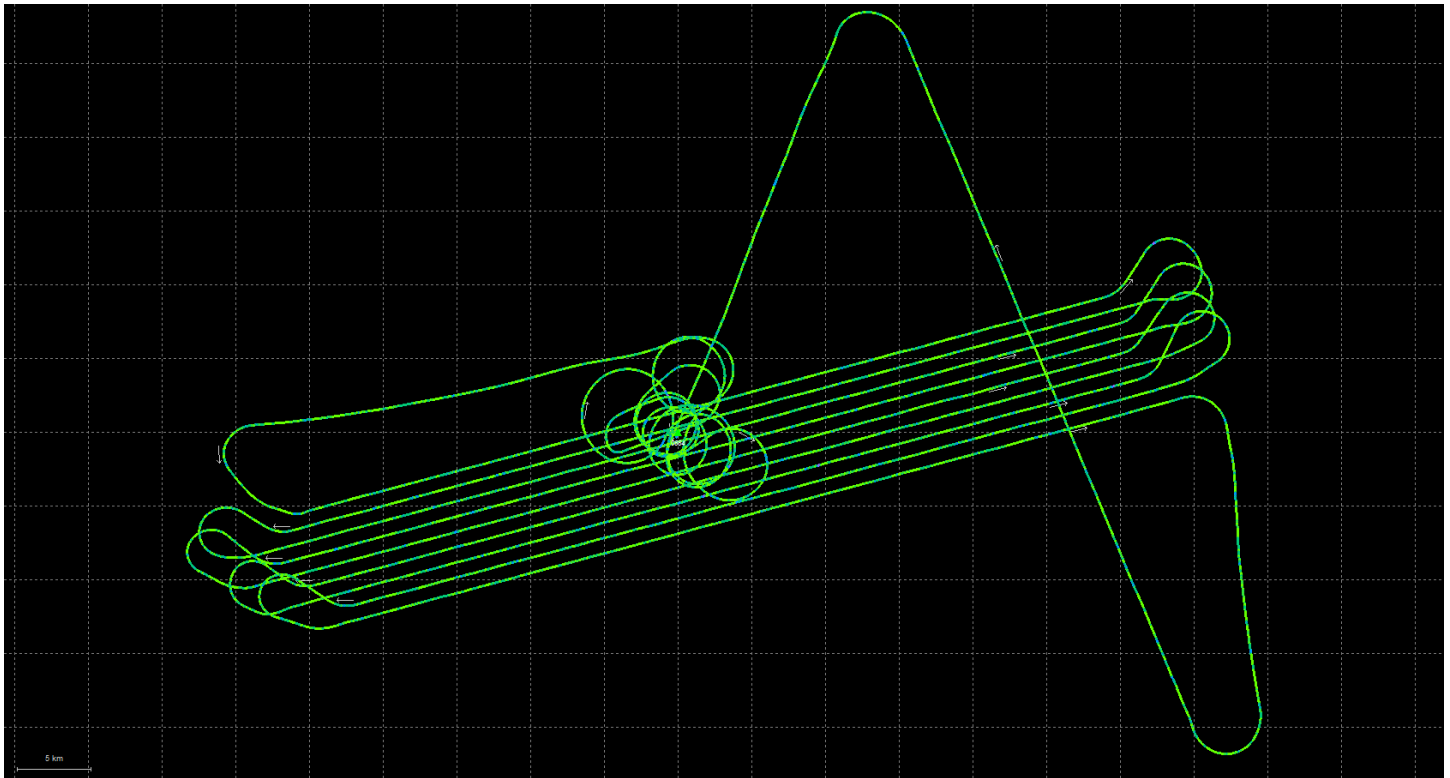

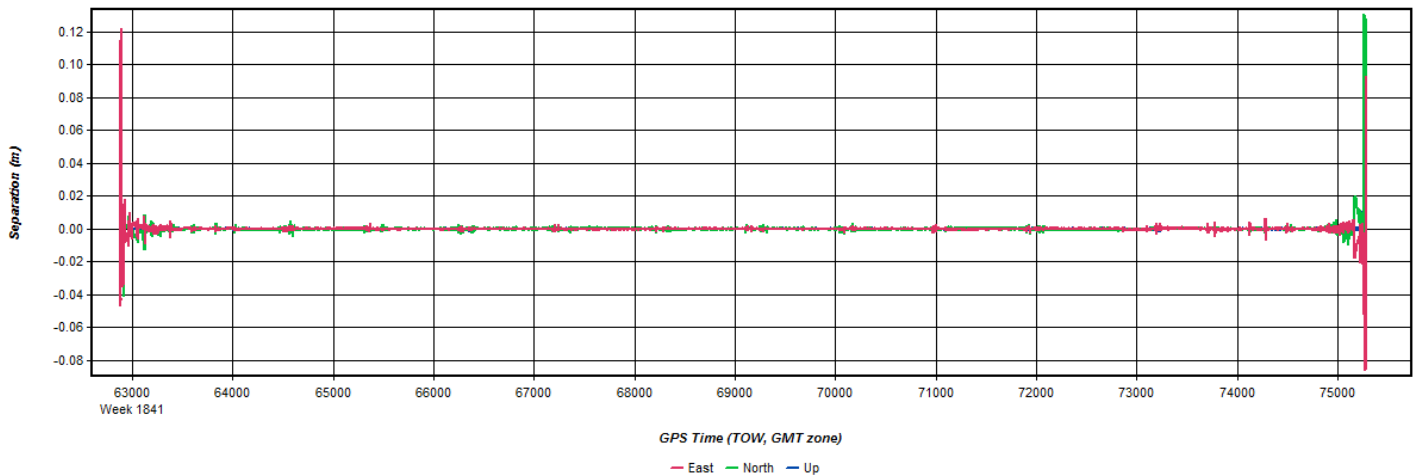
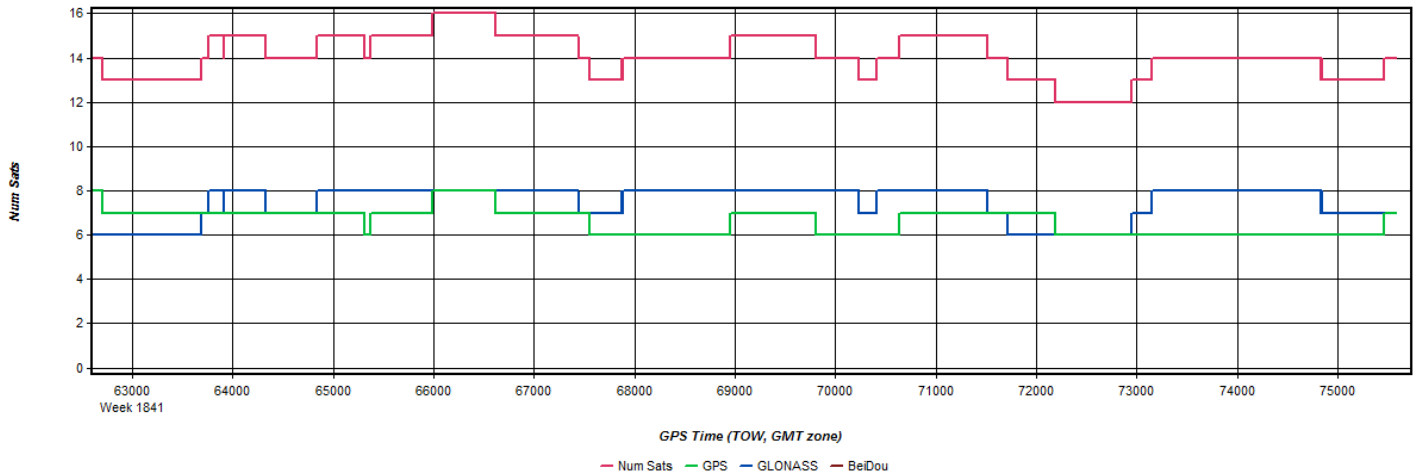

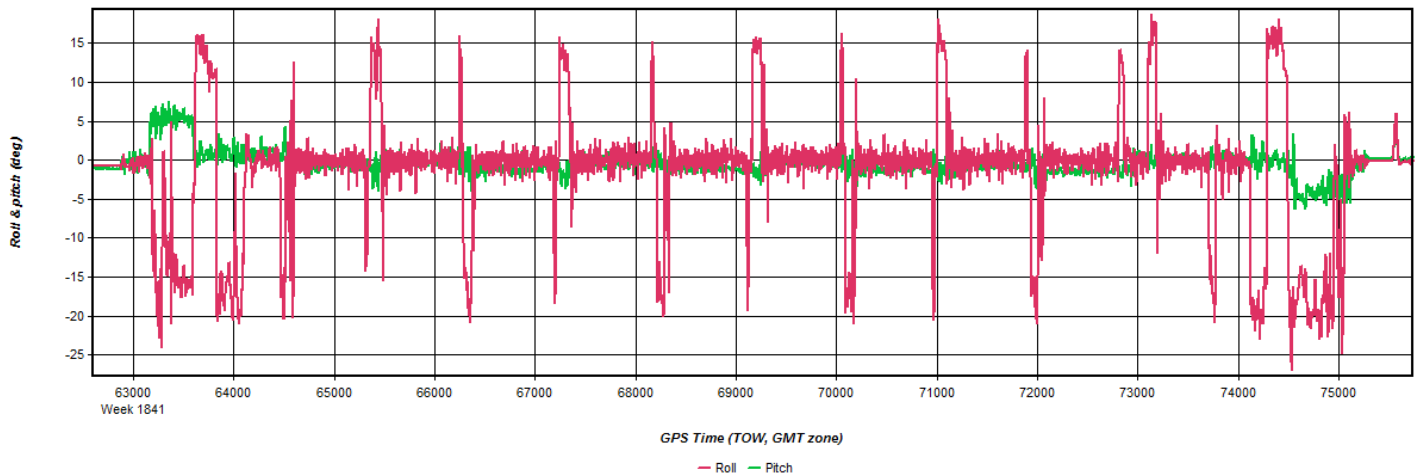
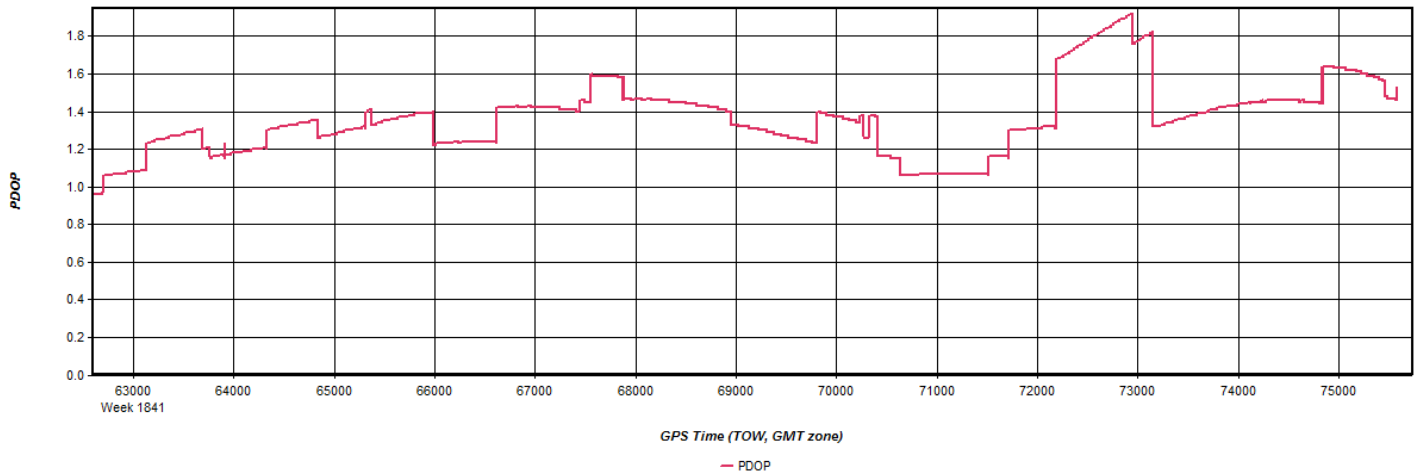

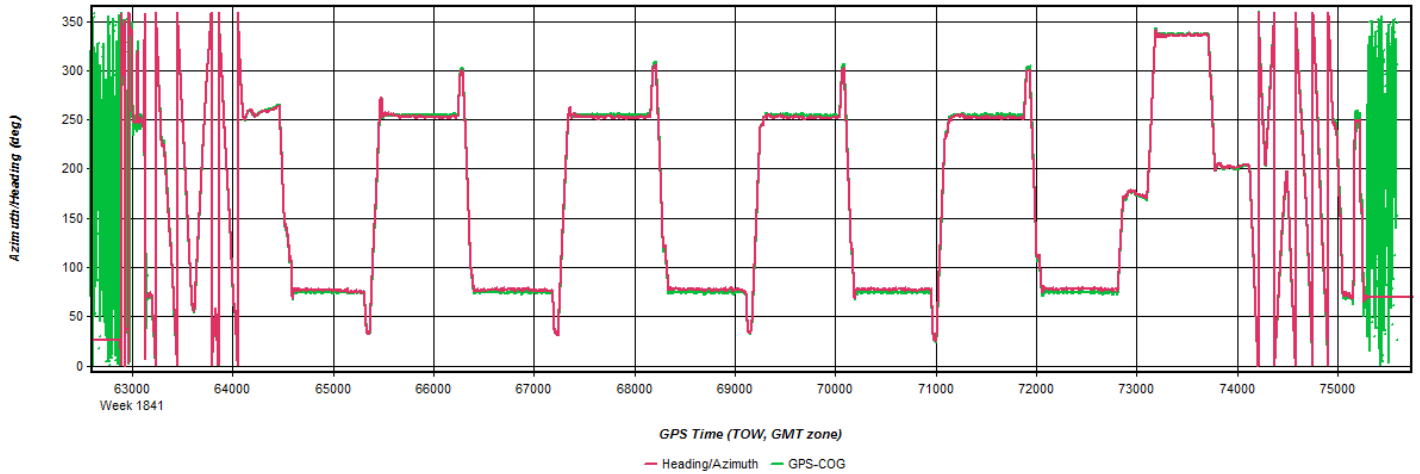

**Coordinate/Antenna Settings**

Master Remote

Base Station  
 1: 0884 Name: 0884  Disabled  
 File: D:\Proc\26236\_dvrpc\Zah1\26236\_20150419\08841090.gpb

Coordinates  
 Latitude: North 39 56 33.93018   
 Longitude: West 74 50 33.02071   
 Ellipsoidal height: -18.796 m   
 Datum: NAD83(2011)

Antenna Height  
 From station file: TRM55971.00   
 Antenna profile: TRM55971.00   
 Measured height: 2.000 m  
 ARP to L1 offset: 0.067 m  
 Applied height: 2.067 m  
 Measured to:  
 ARP  
 L1 Phase Centre

# Flight Log

Scanned by CamScanner

OPERATORS FLIGHT LOG										
MISSION: s 150419-120836		OPERATOR: M Aust		DATE: 4-19-15		AIRCRAFT: 262AS				LEICA ALS-70
PILOT: J BARHAM		OPERATOR: M Aust		DATE: 4-19-15		AIRCRAFT: 262AS				778
PROJECT NUMBER	LINE NO. & Hdg	FREQ Hz	SCAN ANGLE	PRF kHz	FIXED GAIN	ALT (m)	TIME START	TIME STOP	REMARKS	
26236	6001	53	40	273	255					
USGS	6002					6340'	12:54	1303	SMOOTH	
DELAWARE VALLEY	6002					6350'	1307	1317		
	6011					6400'	1320	1331	CLEARED INTO RESTRICTED AREA	
	6012					6420'	1335	1345		
	6013					6360'	1349	1400		
	6014					6310'	1404	1415		
	6015					6390'	1418	1429		
	6016					6450'	1433	1445		
	6017					6430'	1449	1500		
	6018					6440'	1504	1515		
	6048					6380'	1526	1535	APPROXIMATELY CROSSFLIGHT- END LIET A	
	6019					6410'	1756	1808	BEGIN LIET B	
	6020					6470'	1811	1823	150419_172024	
	6021					6430'	1827	1839		
	6022					6420'	1843	1855		
	6023					6460'	1859	1911		
	6024					6440'	1915	1926		
STATUS	TOTAL LINES	FLOWN	LEFT	AIRCRAFT		STATIC	START	STOP	NOTES: PAGE 1	
	48	10	38	KVA4	FERRY	5 MIN	8:15	12:10	← LIET A	
	48	10	28	KVA4	n/a	W/ CLEAR WITH A LITTLE HAZE			1:10p START- 5:00 STOP - LIET B	

AERO-METRIC, INC. N.6216 Resource Drive Sheboygan Falls, WI. 53085 PHONE: 920-487-2655 FAX: 888-253-6695 E-Mail: amphoto@aerometric.com



Scanned by CamScanner

OPERATORS FLIGHT LOG											
MISSION: s 150419.120836			DATE: 4-19-15			LEICA ALS-70			AIRCRAFT: 26245		
PILOT: J BARHAM			OPERATOR: 104 AUST			MM70 DRIVE			REMARKS		
PROJECT NUMBER	LINE NO. & Hdg	GND SPEED (KTS)	FREQ HZ	SCAN ANGLE	PRF KHZ	FIXED GAIN	ALT (m)	TIME START	TIME STOP		
26236			53	40	273	255					
USGS	6025 75°	154					6480	1930	1942		CONTINUE LIFT B
DELAWARE VALLEY	6026 255°	154					6450	1945	1957		150419.172024
	6027 75°	155					6475	2001	2013		
	6047 337°	187					6420	2020	2028		CROSSFLIGHT END LIFT B
STATUS	TOTAL LINES	FLOWN	LEFT	SITE	AIRCRAFT	FERRY	STATIC	START	STOP	NOTES	
○	48	10	38	KVAY		15min	5min	8:15	13:10		← LIFT A
○	48	10	28	KVAY	n/a		N/A	HAZE			1:10 START - 5:00 STOP ~ LIFT B
○											

AERO-METRIC, INC. N.6216 Resource Drive Sheboygan Falls, WI. 53085 PHONE: 920-467-2655 FAX: 888-253-6695 E-Mail: amphoto@aerometric.com

# Base Station Log



**Station Occupation Report  
For Airborne GPS**

Project: USGS DELAWARE VALLEY

Location: KVAY

Project Number: 26236

Completed by: M AUST

Date: 4-19-15

Receiver: TRIMBLE R7

Receiver Type: \_\_\_\_\_

Antenna Type: \_\_\_\_\_

Station ID: SET POINT

Start -- H.I. (m): 2m

End -- H.I. (m): 2m

H.I. (ft): \_\_\_\_\_

Start Time: 8:00am

End Time: 5:00pm

Time Zone: EST

Operator: M AUST



Comments SET POINT

\_\_\_\_\_  
\_\_\_\_\_  
\_\_\_\_\_  
\_\_\_\_\_  
\_\_\_\_\_  
\_\_\_\_\_

# Apr 19, 2015-A (N269JE, SN7234)

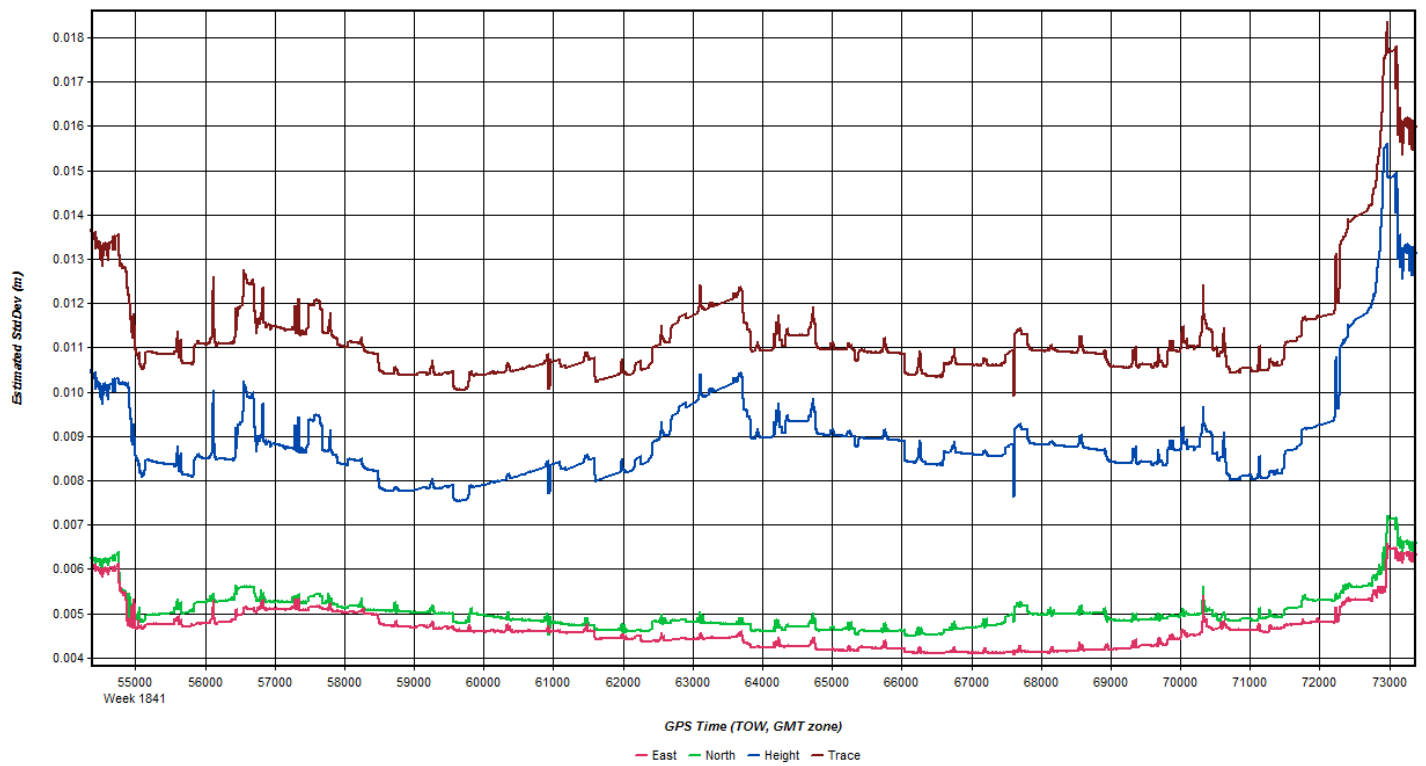
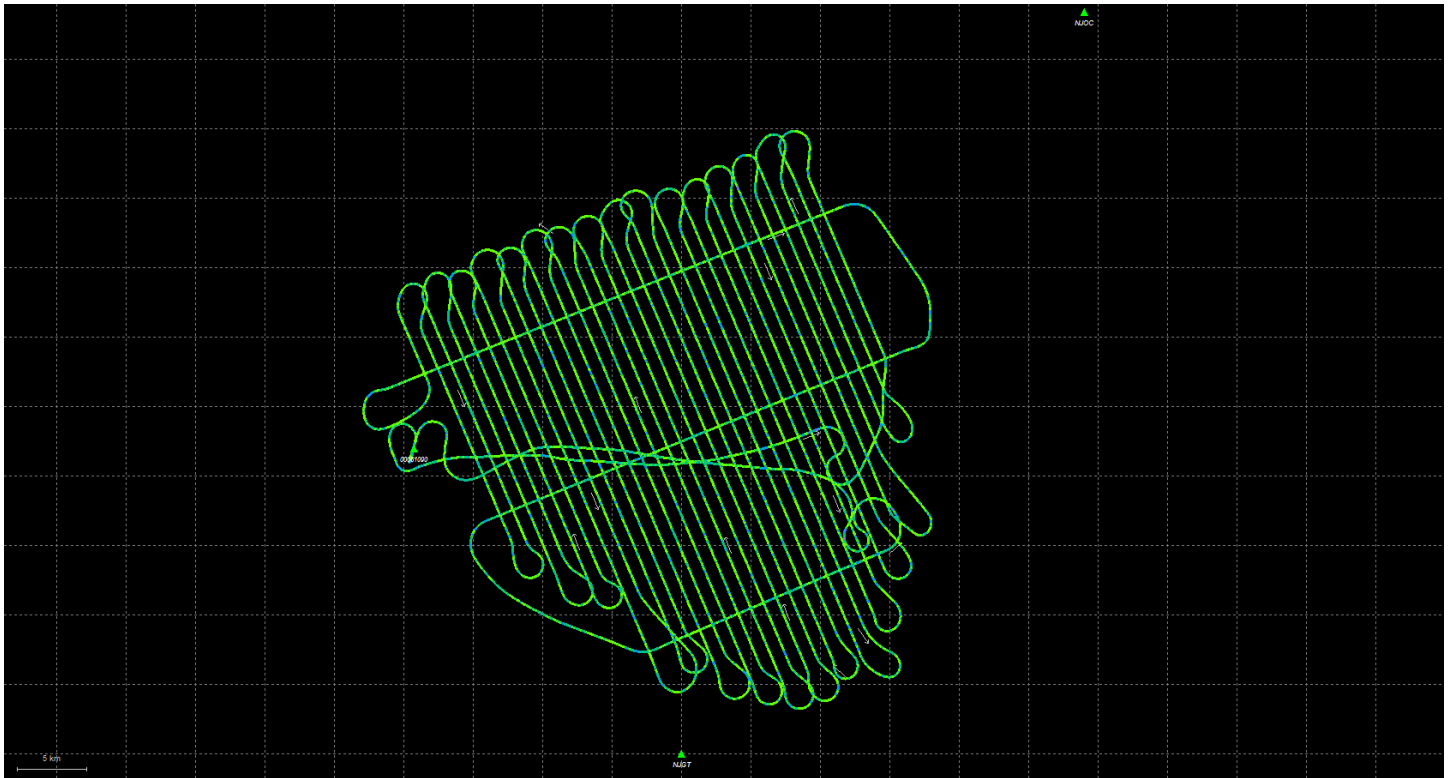

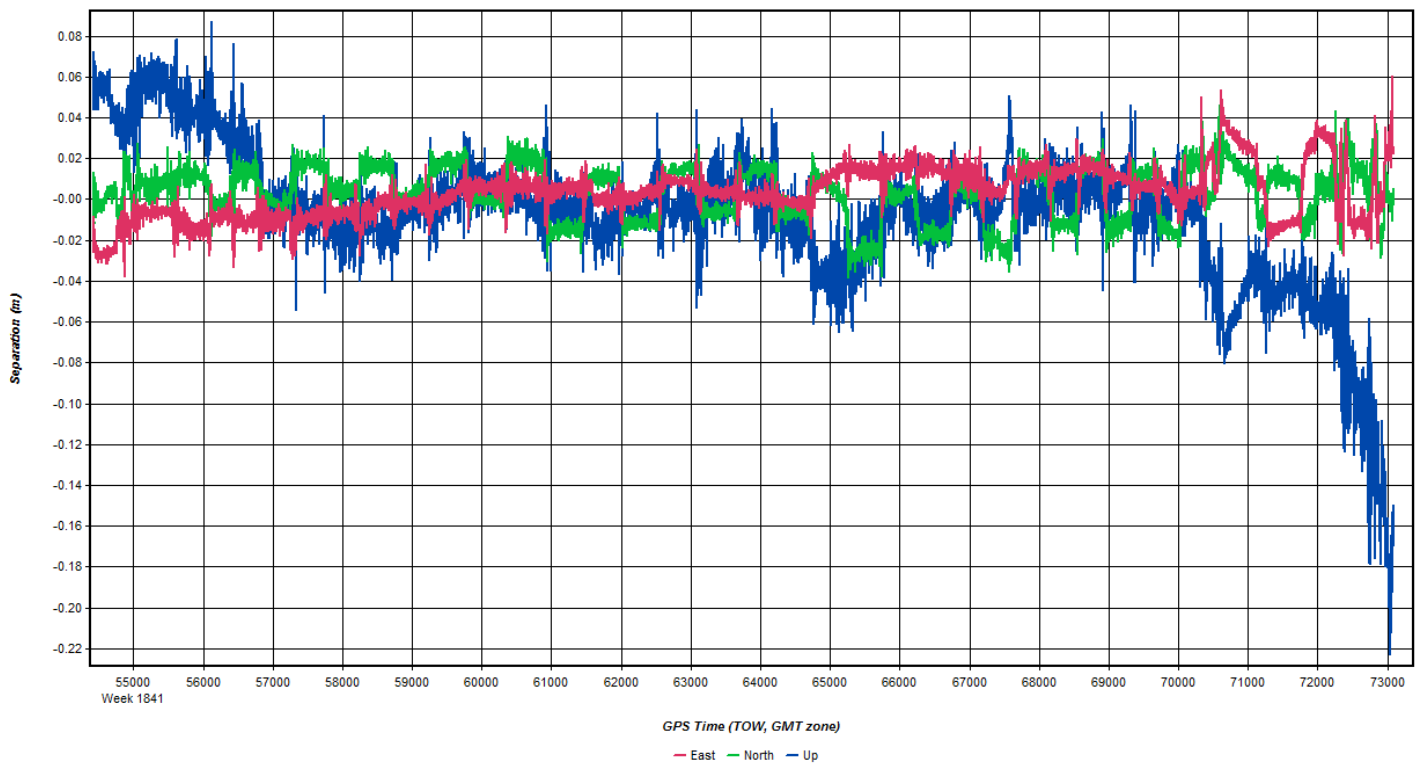
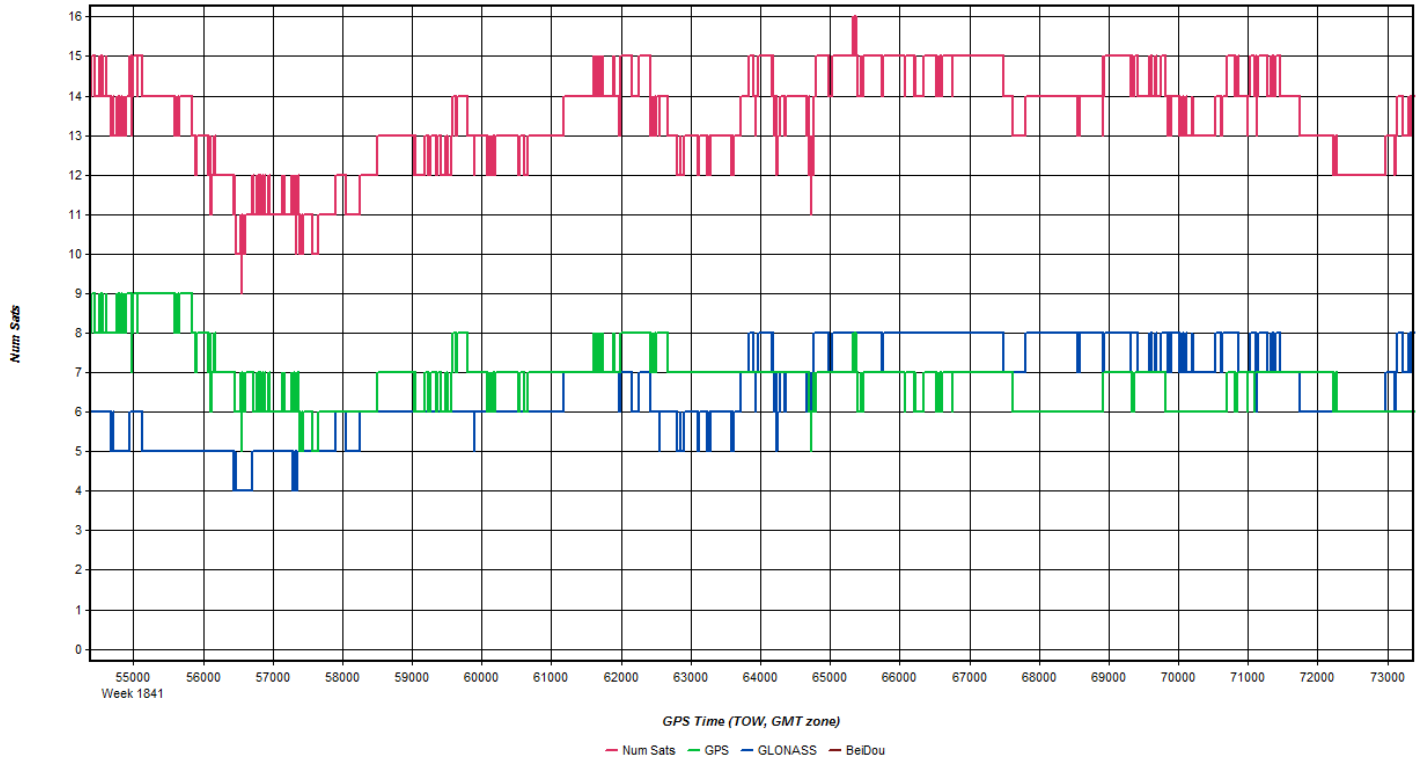

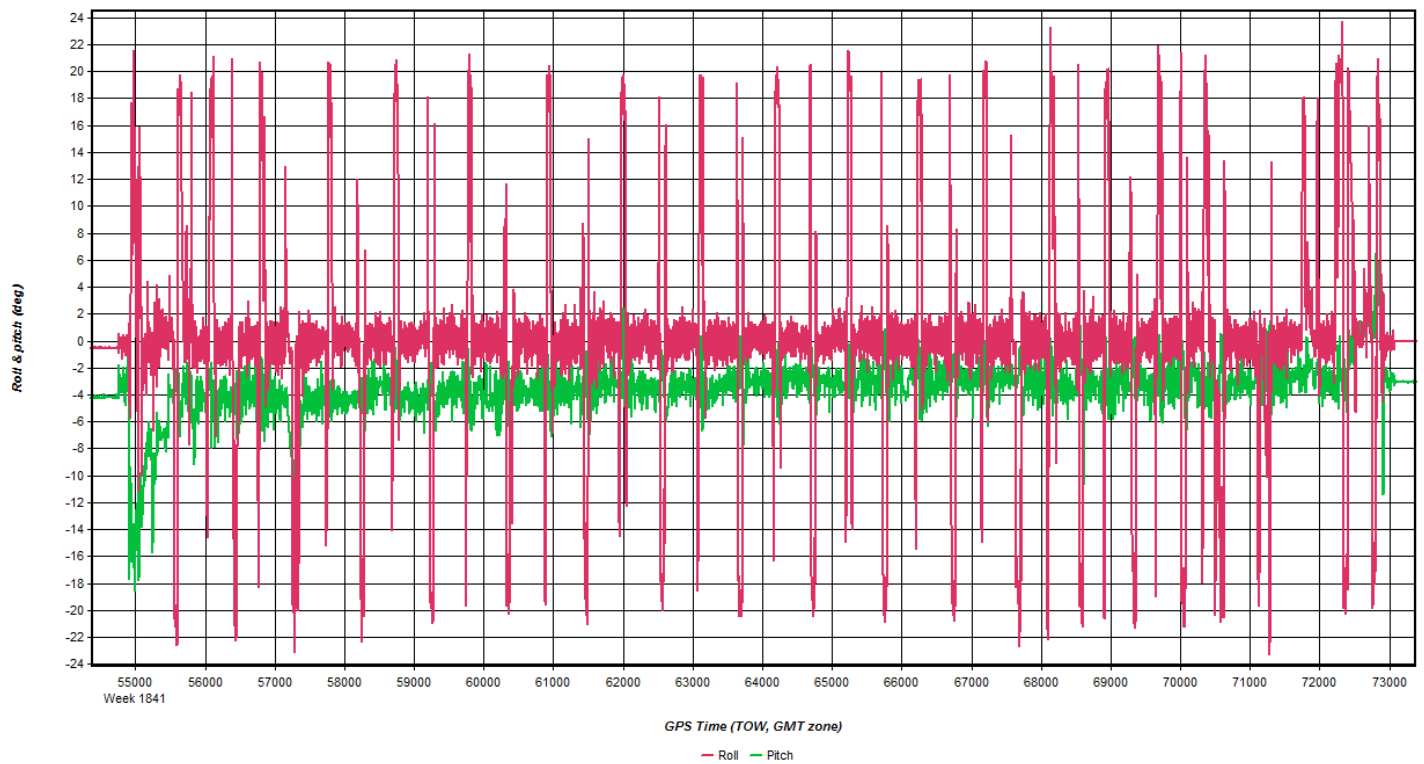
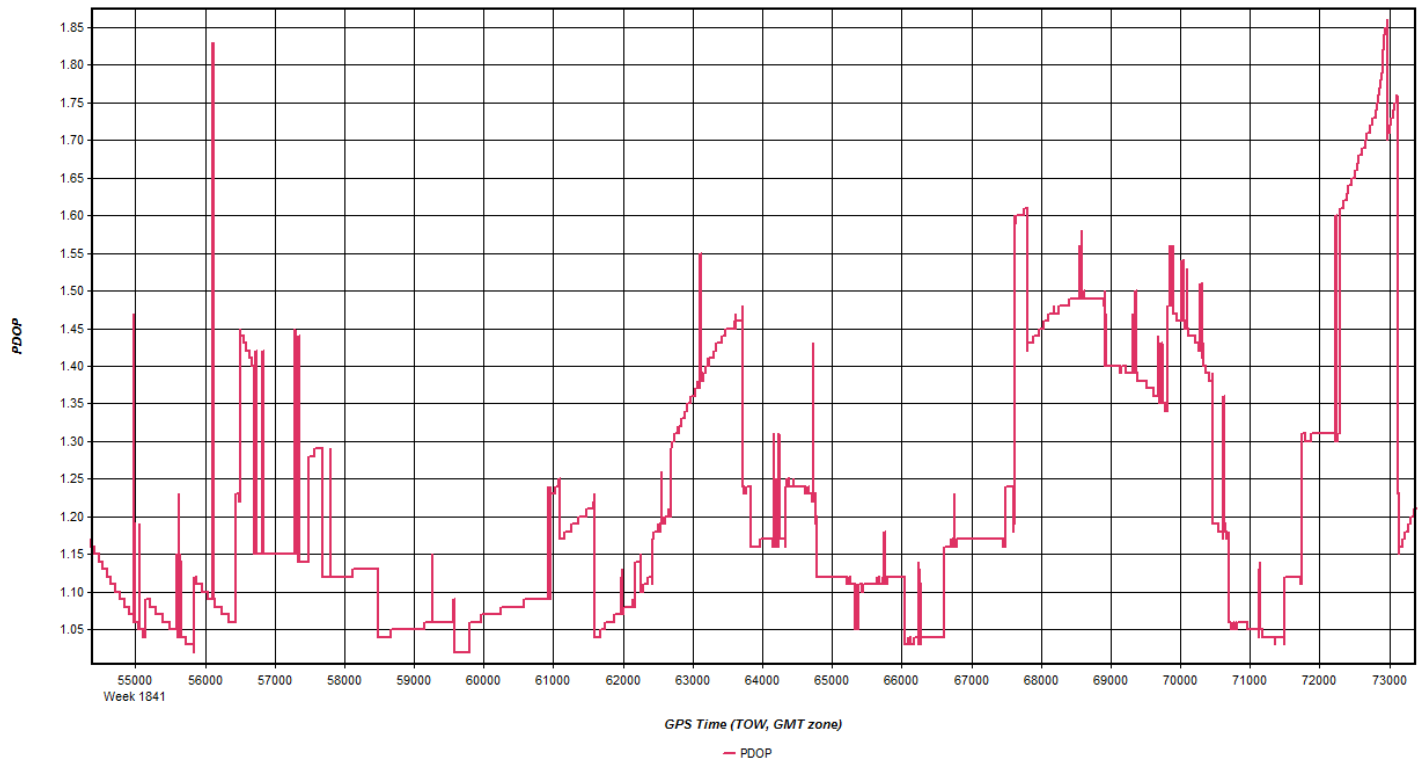

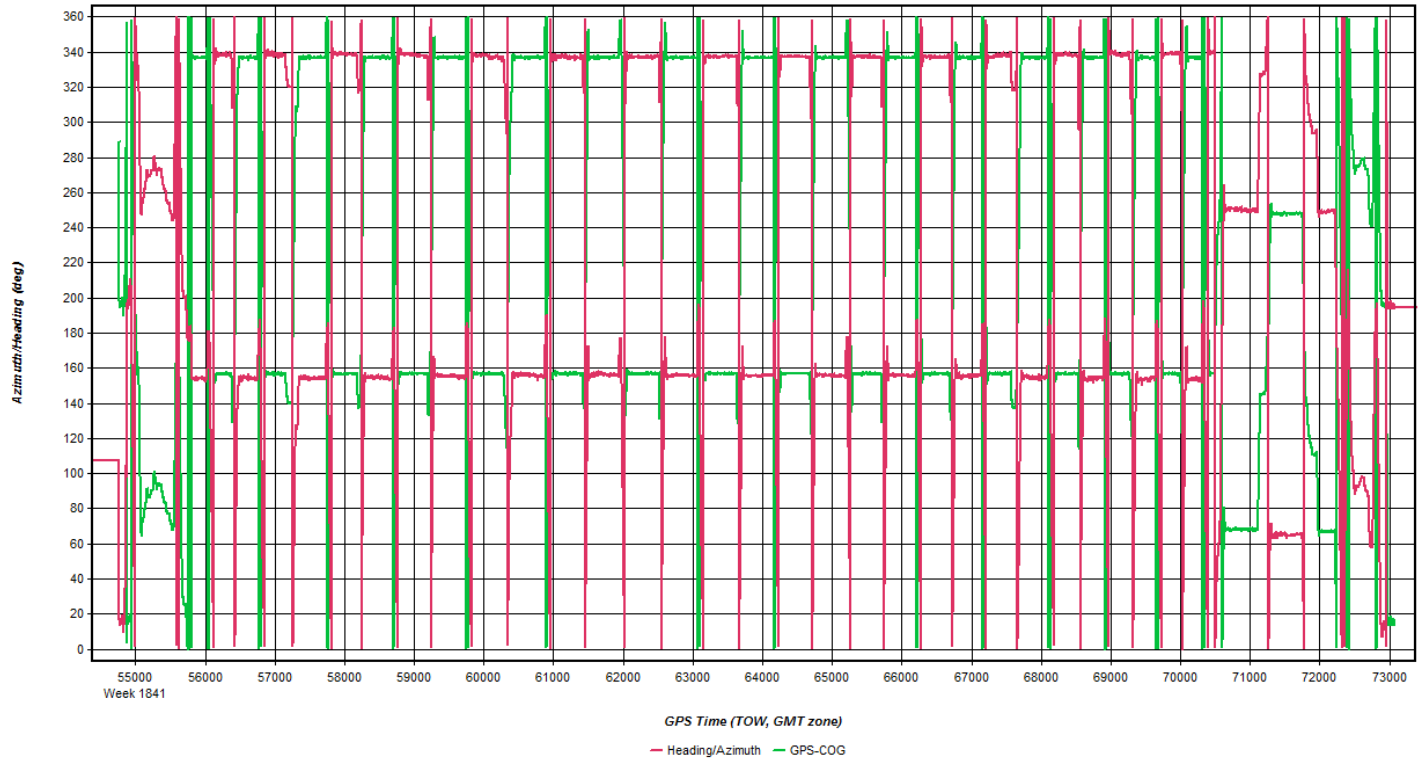

**Coordinate/Antenna Settings**

Master Remote

Base Station  
 Name: 00081090  Disabled  
 File: D:\Proc\26236\_DVRPC\4739\20150419\_150058\Base\_Data\00

Coordinates  
 Latitude: North 39 40 17.53623   
 Longitude: West 74 45 20.45774   
 Ellipsoidal height: -15.919 m   
 Datum: NAD83(2011)

Antenna Height  
 From station file: N/A   
 Antenna profile: NOV702GG\_1.03   
 Measured height: 1.500 m  
 ARP to L1 offset: 0.069 m  
 Applied height: 1.569 m  
 Measured to:  
 ARP  
 L1 Phase Centre



Coordinate/Antenna Settings

Master Remote

Base Station  
 1: NJGT Name: NJGT  Disabled  
 File: D:\Proc\26236\_DVRPC\4739\20150419\_150058\njgt1090.gpb

Coordinates  
 Latitude: North 39 28 28.25439 Compute from PPP  
 Longitude: West 74 31 50.93862 Enter Grid Values  
 Ellipsoidal height: -11.096 m Enter MSL Height  
 Datum: NAD83(2011) Datum Options  
 Select From Favorites Add To Favorites Use Average Position

Antenna Height  
 From station file: LEIAT504GG, LEIS View STA File  
 Antenna profile: LEIAT504GG, LEIS Info

Measured height: 0.000 m Measured to  
 ARP  
 L1 Phase Centre  
 ARP to L1 offset: 0.087 m Compute From Slant  
 Applied height: 0.087 m

OK Cancel

Coordinate/Antenna Settings

Master Remote

Base Station  
 2: NJOC Name: NJOC  Disabled  
 File: D:\Proc\26236\_DVRPC\4739\20150419\_150058\njoc1090.gpb

Coordinates  
 Latitude: North 39 57 10.02328 Compute from PPP  
 Longitude: West 74 11 36.59328 Enter Grid Values  
 Ellipsoidal height: -8.184 m Enter MSL Height  
 Datum: NAD83(2011) Datum Options  
 Select From Favorites Add To Favorites Use Average Position

Antenna Height  
 From station file: LEIAR10, NONE View STA File  
 Antenna profile: LEIAR10 Info

Measured height: 0.000 m Measured to  
 ARP  
 L1 Phase Centre  
 ARP to L1 offset: 0.089 m Compute From Slant  
 Applied height: 0.089 m

OK Cancel

# Flight Log

## DVRPC 31E Eagles Nest SN7234 QL2



QSI Project #	26236
Sensor Name	ALS70 SN7234
Flight Plan Style	Fixed MSL
Project Point Density (pts/m <sup>2</sup> )	2

Flight Plan Settings	
DEM Used for Planning	SRTM 30m
Target Speed (kts)	150
Max Bank Angle in Turns (°)	30
Minimum Line Overlap (%)	30
Pulses in Air Mode	MPIA
Scan Pattern	Triangle
Fixed Gain	255
Roll Comp. (ON/OFF)	N/A
Allowed vertical deviation (m)	
	<b>Min.</b>
	<b>Max</b>
AGL (m) varies by line	2000
MSL (ft) varies by line	6427
FOV Range (°)	40.0
Scan Rate (Hz)	53.4
Swath Width (m)	1456
Laser Power (%)	100
Pulse Rate (Hz)	273000

\*Shading = Auto-calculated

### Other Acquisition Notes:

Lines should be flown at the altitude (in FEET above sea level) indicated on the flight sheet. Give this number to the pilot for each line and have him use the altimeter on his instrument panel. The plane's altimeter is adjusted for pressure. Please note that each line is at a different altitude.

Project Flight Time Estimate	
Total Line Length (nmi)	441
Total Line Time (hrs, no buffer)	2.9
Total Number of Lines	35
Turn Time (min)	4
Total Turn Time (hrs, no buffer)	2.3333
Buffer (%)	10
MOB Dist. Round Trip (nmi)	60
Number of MOBs	3
Total Acquisition Time (hrs)	7.0

Mission Flight Time Estimate	
Start Line Name	1001
Stop Line Name	1042
Turn Time (min)	4
Buffer (%)	10
Acquisition Time (hrs)	#N/A

Line Name	Total Line Length [nmj]	Flying Altitude [ft MSL]	Time Stamp	Refly Time Stamp	Sats./P DOP	Notes (Direction, Atmospheric Conditions, Speed, PR, Errors, etc.)
8001	6	6539	153015		17/1.1	
8002	8	6529	153547		16/1.1	
8003	9	6522	154125		16/1.1	
8004	10	6509	154757		17/1.0	
8005	11	6512	155610		17/1.0	
8006	13	6492	160254		16/1.1	
8007	14	6470	161133		15/1.2	
8008	15	6479	161945		15/1.2	
8009	16	6444	162815		15/1.2	
8010	16	6437	163718		15/1.3	
8011	16	6444	164708		16/1.1	
8012	16	6434	165616		16/1.2	
8013	16	6427	170514		16/1.3	
8014	17	6427	171415		16/1.3	
8015	17	6437	172329		17/1.2	
8016	17	6427	173300		18/1.1	
8017	17	6434	174208		17/1.2	
8018	16	6430	175100		17/1.3	
8019	16	6437	175942		17/1.4	
8020	15	6430	180819		18/1.3	
8021	15	6437	181653		18/1.3	
8022	14	6437	182517		17/1.4	
8023	14	6434	183310		16/1.5	
8024	12	6439	184044		17/1.4	
8025	11	6444	184953		18/1.2	
8026	11	6440	185658		17/1.4	
8027	9	6444	190351		16/1.5	
8028	9	6444	191001		15/1.0	
8029	9	6450	191634		18/1.1	
8030	9	6457	192341		18/1.1	
8031	2	6483	193020		18/1.1	
8032	1	6499	193352		19/1.1	

pilot display flashed quick cable error, then back to normal

8029	18	6483	193715	19/10	CROSS LINE
8030	16	6457	194030	18/11	CROSS LINE
8031	8	6434	195952	18/11	CROSS LINE

# Base Station Log

### GPS OBSERVATION LOG

Station ID	<u>NA @ Airport n81</u>	Date	<u>04 / 19 / 2015</u>
Project Number	<u>26236</u>	Julian Date	<u>110</u>
Project Name	<u>DVRPC Eagles Nest</u>	Start Time	<u>10 : 27 : 00 :</u>
Rcvr. Type	<u>Novatel DL V3 L1 L2</u>	Stop Time	<u>16 : 23 : 00 :</u>
Rcvr. S/N	<u>7-0141418</u>	Revr. File Name	
Antenna Type	<u>Novatel 1.03 Hw Rev</u>	Observer	<u>Charlie Onca</u>
Antenna S/N	<u>01017577</u>		

*NOVATEL 70266 1.03*

New or Existing  
 Mon.  New  
 Existing  
 Photo Taken:  
 Yes  No

Monument Type:  
 Spike PK Nail  
 AM Washer

Other

Monument we needed could not be located, and I had no gear to set another. We found a benchmark from another company and used that. Type is small plastic cap.

Height Readings:

(Top of Monument to Bottom of Ground Plane)

Start	<u>1.5</u> M.	Ft.
Stop	<u>1.5</u> M.	Ft.
Mean	<u>1.5</u> M.	Ft.

*fixed height tripod*

Monument Sketch and Notes:

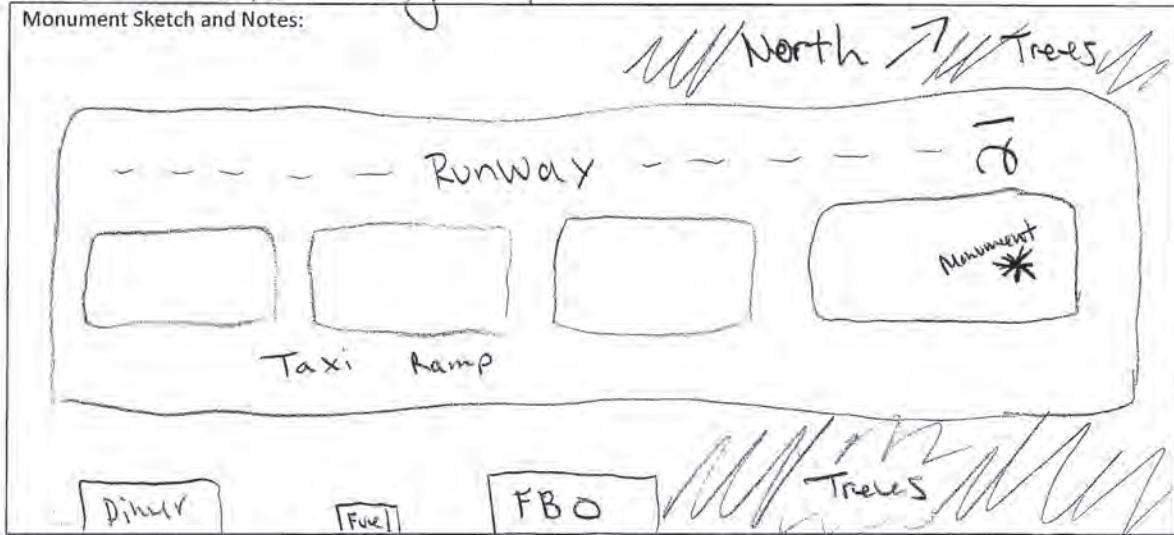

\* Monument marked with orange tape, in line with bottom of 21 on runway

# Apr 19, 2015-A (N22GE, SN8239)



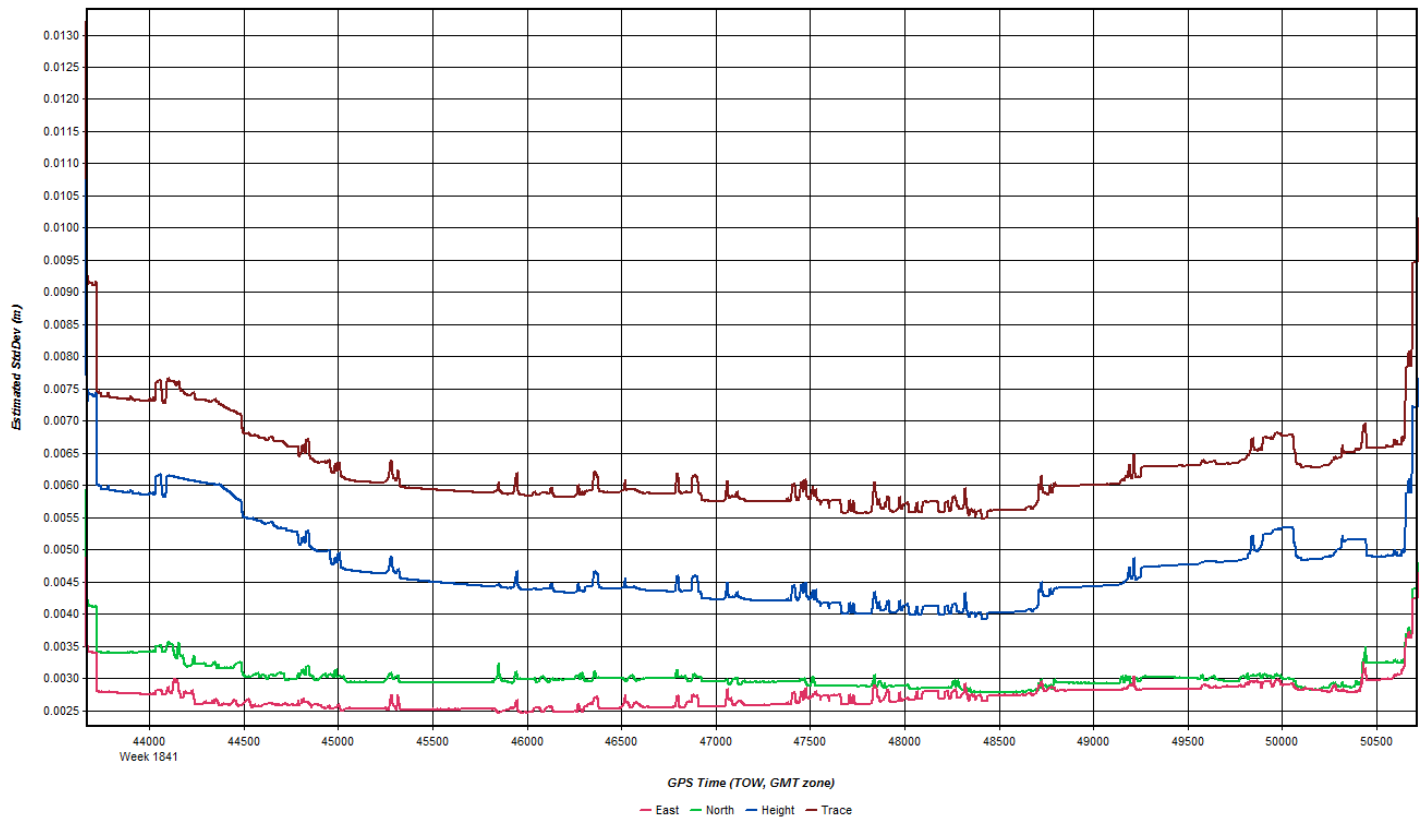
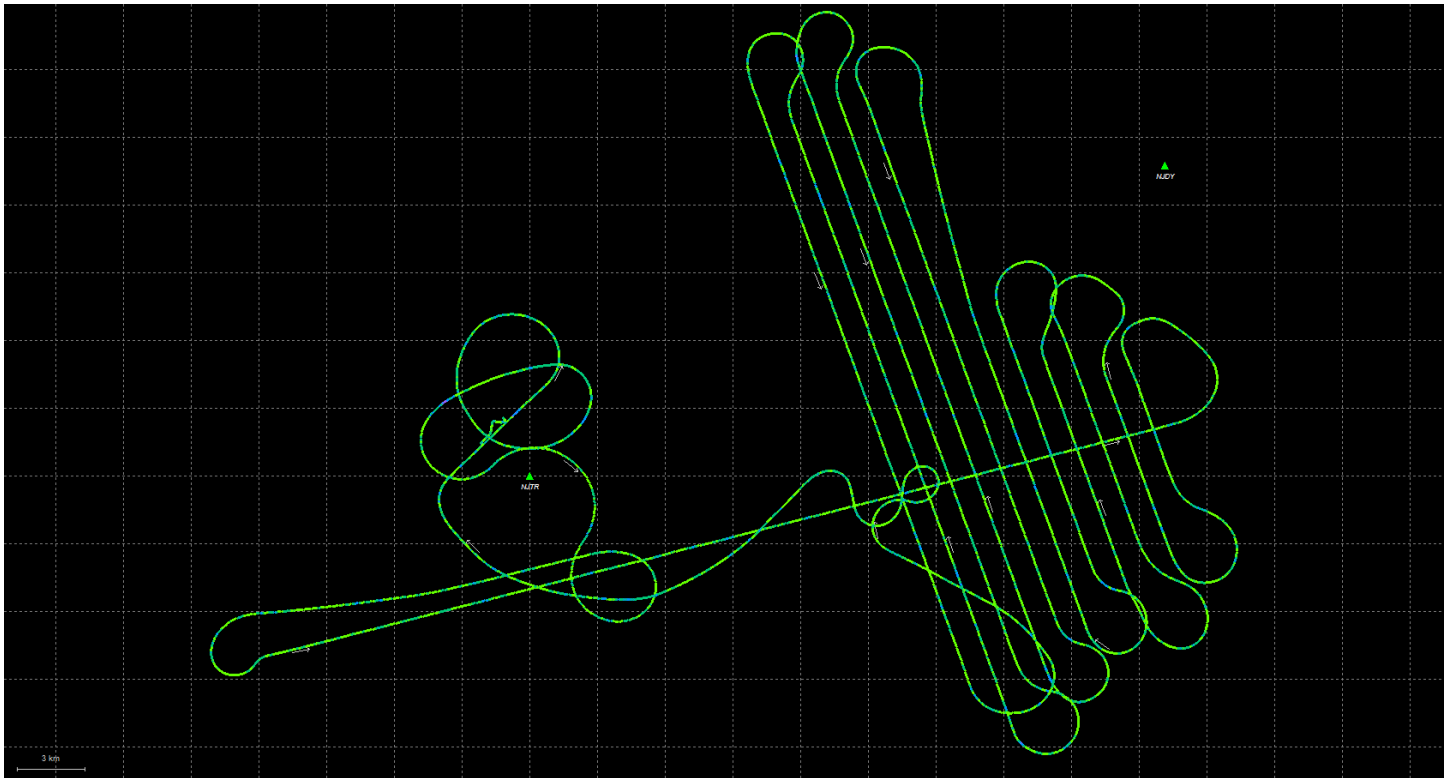

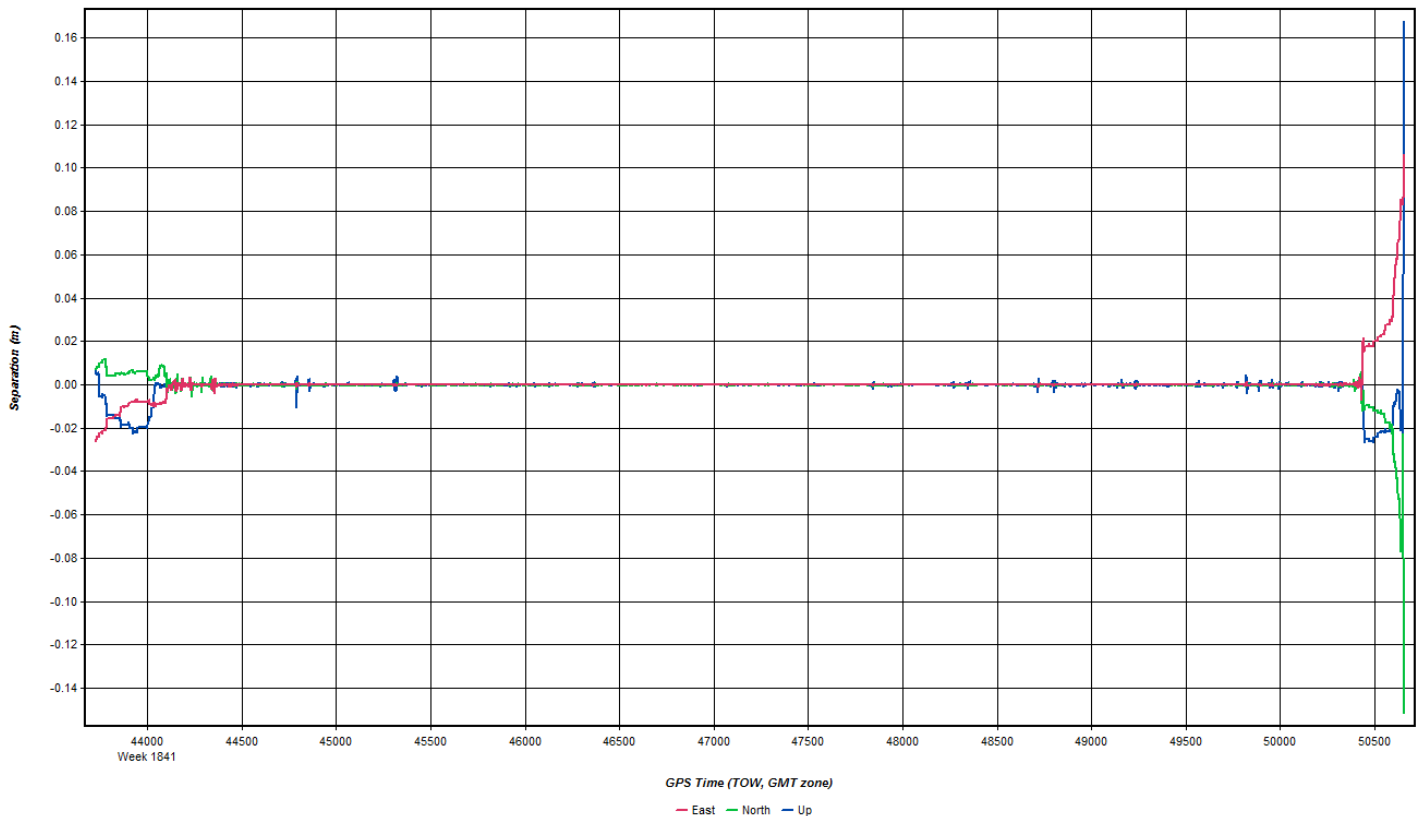
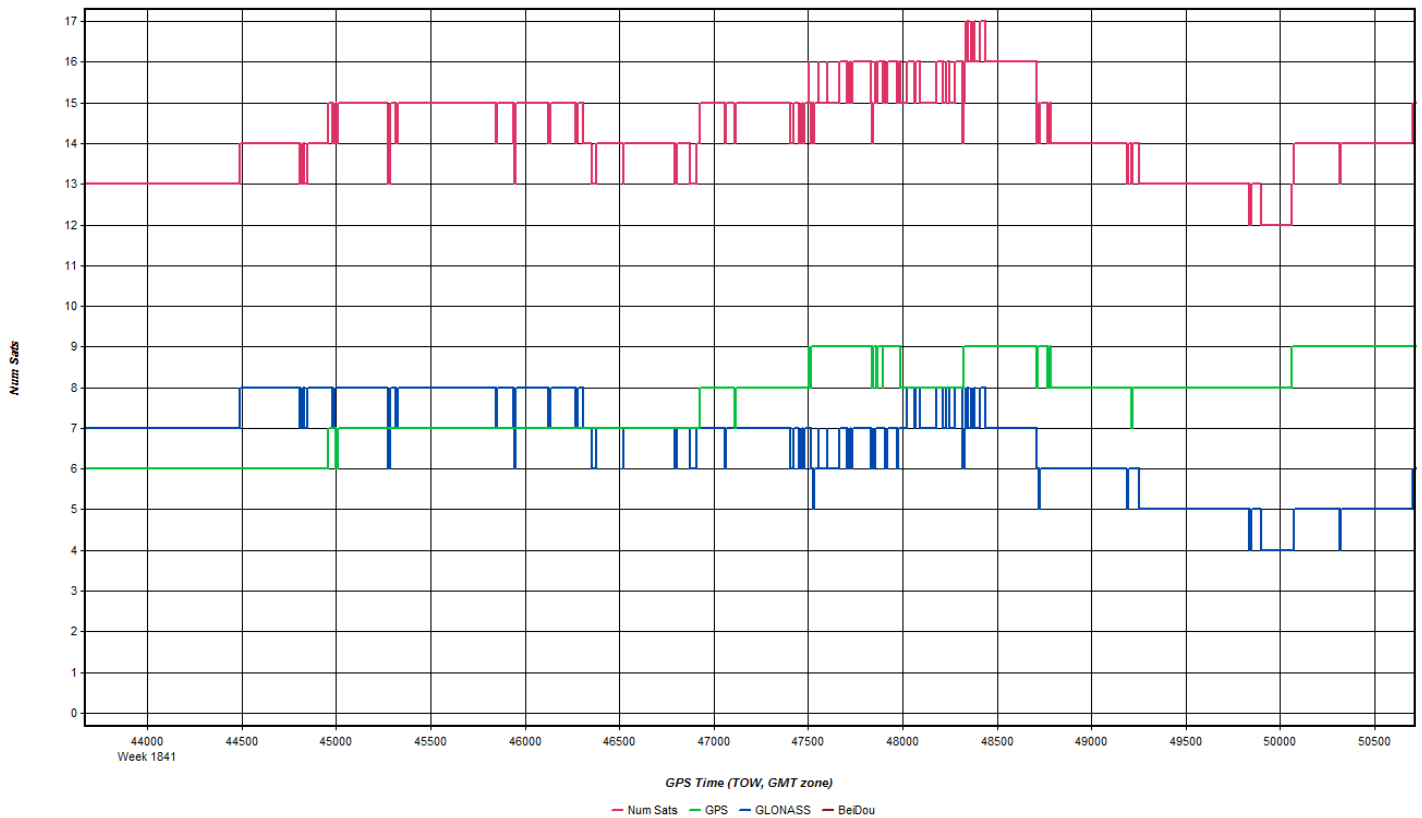

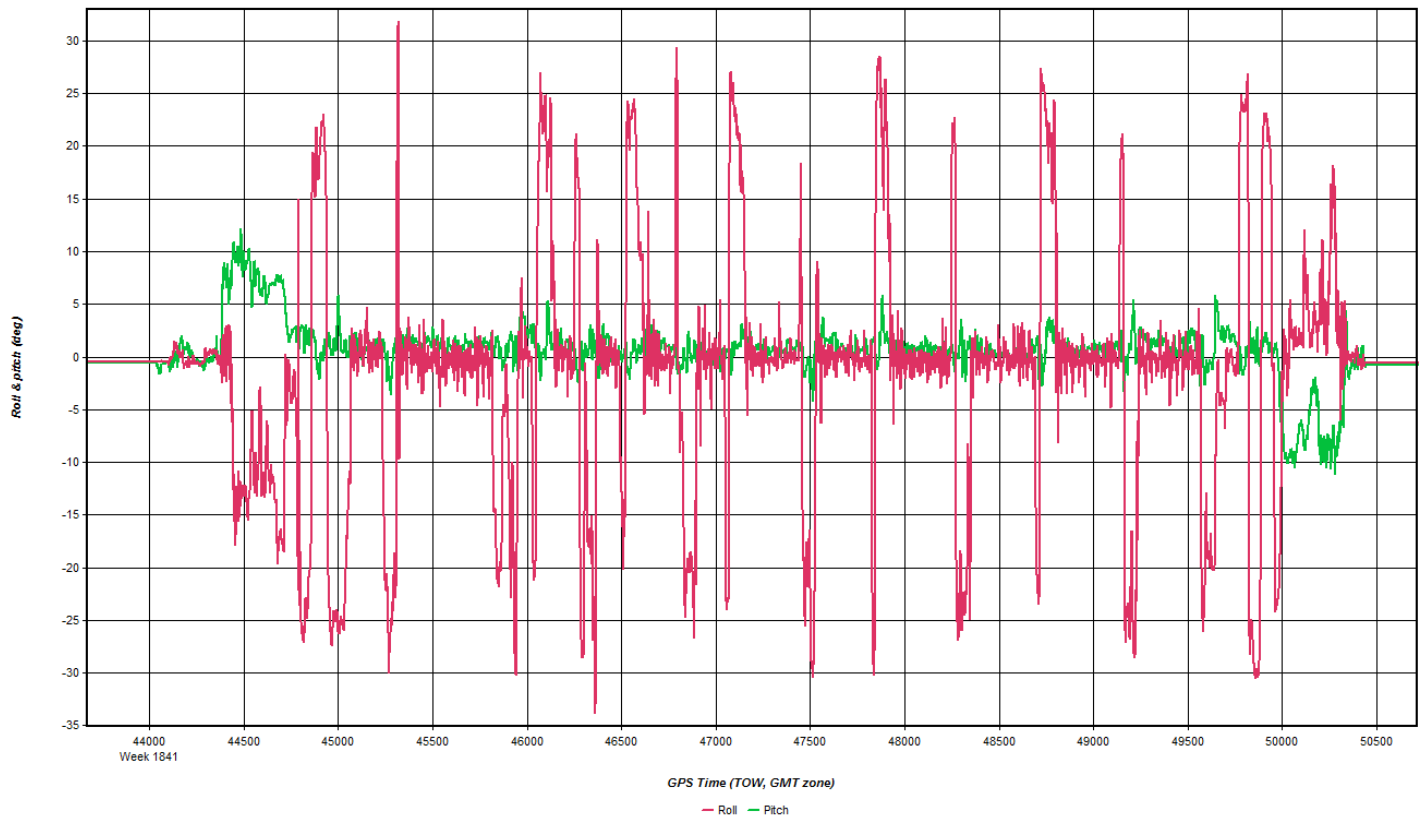
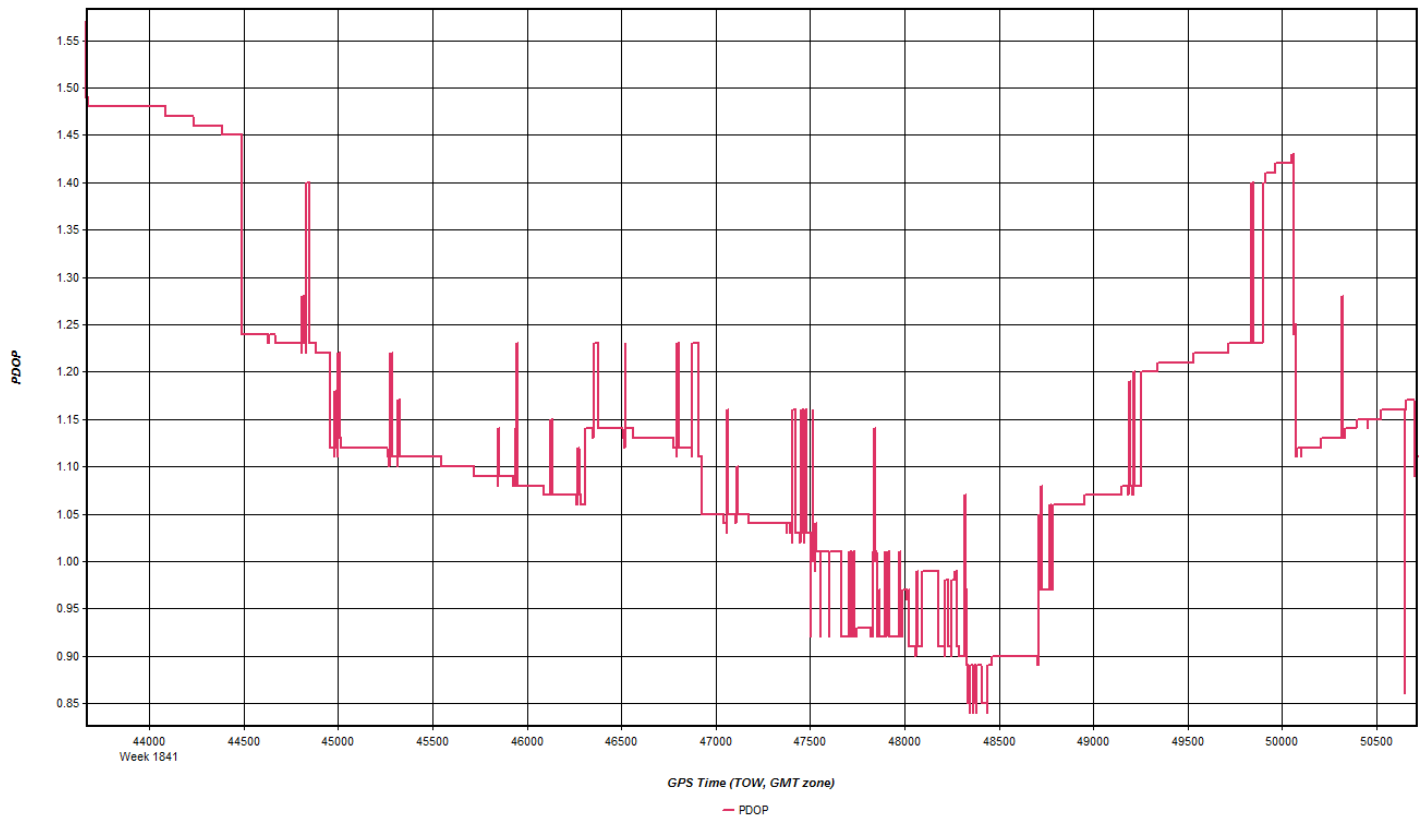

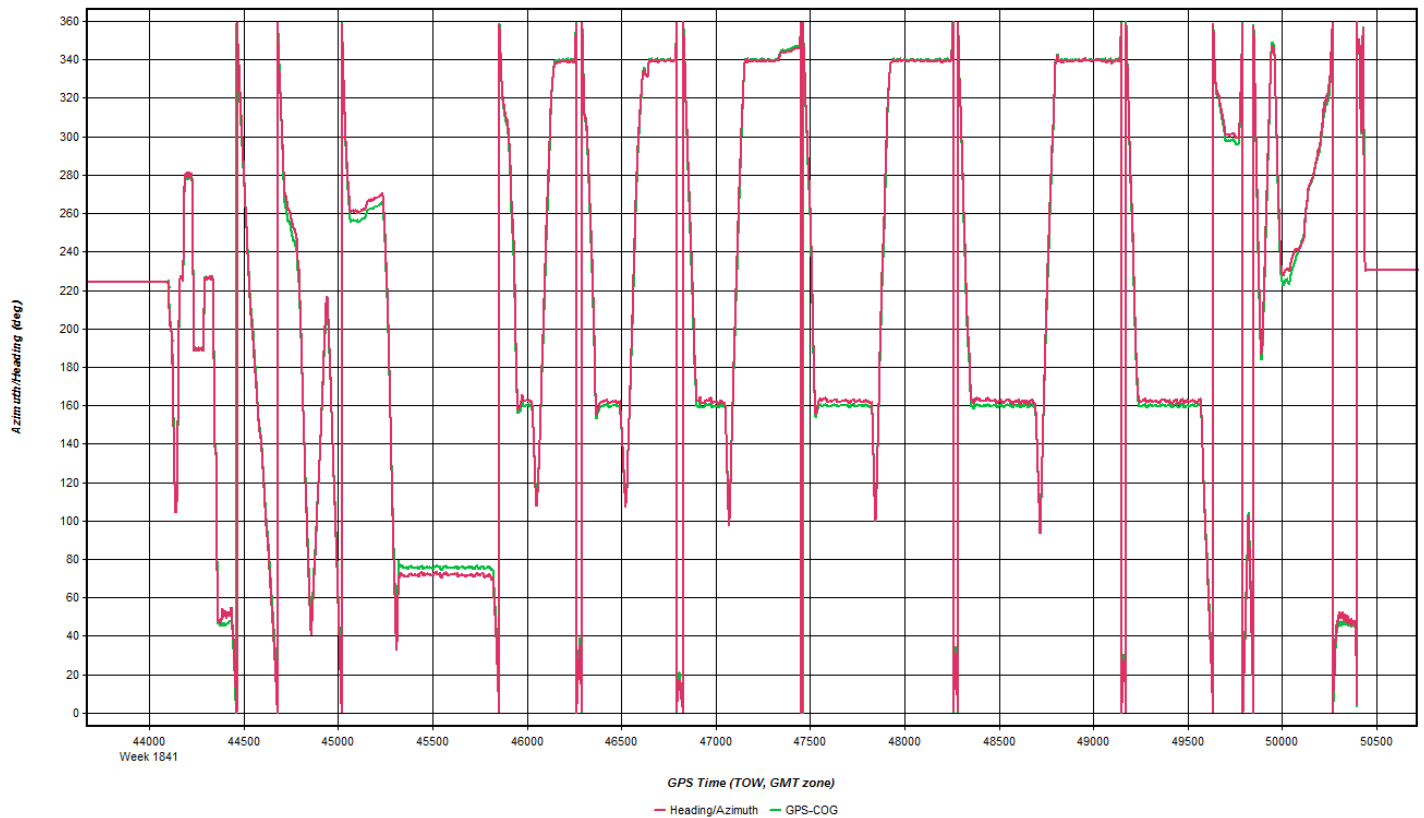

**Coordinate/Antenna Settings**

Master Remote

Base Station  
 2: NJDY Name: NJDY  Disabled  
 File: D:\Proc\26236\_DVRPC\NS6R\20150419\_120555\DVRPC\_N87

Coordinates  
 Latitude: North 40 22 52.07372   
 Longitude: West 74 27 56.30160   
 Ellipsoidal height: 4.283 m   
 Datum: NAD83(2011)

Antenna Height  
 From station file: LEIAR10, NONE   
 Antenna profile: LEIAR10   
 Measured height: 0.000 m  
 ARP to L1 offset: 0.089 m  
 Applied height: 0.089 m  
 Measured to:  
 ARP  
 L1 Phase Centre

Coordinate/Antenna Settings

Master Remote

Base Station  
1: NJTR Name: NJTR  Disabled  
File: D:\Proc\26236\_DVRPC\NS6R\20150419\_120555\DVRPC\_N87

Coordinates  
Latitude: North 40 15 27.46254   
Longitude: West 74 47 48.07181   
Ellipsoidal height: 41.271 m   
Datum: NAD83(2011)

Antenna Height  
From station file: LEIAR10, NONE   
Antenna profile: LEIAR10   
Measured height: 0.000 m  
ARP to L1 offset: 0.089 m  
Applied height: 0.089 m  
Measured to:  
 ARP  
 L1 Phase Centre

OK Cancel

# Flight Log



# Base Station Log



### GPS OBSERVATION LOG

Station ID KTIN Airport  
 Project Number 26236  
 Project Name USGS DVRPC Q62  
 Rcvr. Type Novatel DL-V3-L1L2  
 Rcvr. S/N 7-0141149  
 Antenna Type Novatel GPS-702-66  
 Antenna S/N NAE12110034

Date 4 / 19 / 2015  
 Julian Date 109  
 Start Time 7 : 50 : 21 : AM  
 Stop Time 3 : 35 : 46 : PM  
 Rcvr. File Name 00071090.PDL  
 Observer Dan Rolles

New or Existing

Mon. New

Existing

Photo Taken:

Yes No

Monument Type:

Spike PK Nail

AM Washer

Other concrete block w/ divet mark

Height Readings:

(Top of Monument to Bottom of Ground Plane)

Start	2 M.	Ft.
Stop	2 M.	Ft.
Mean	2 M.	Ft.

Monument Sketch and Notes:

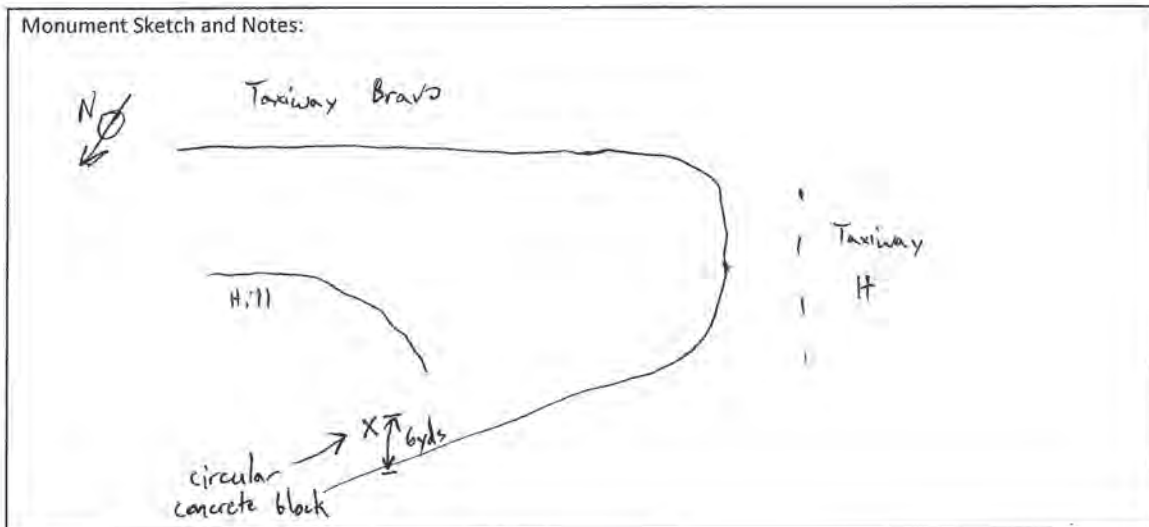

**Apr 19, 2015-B  
(N22GE, SN8239)**

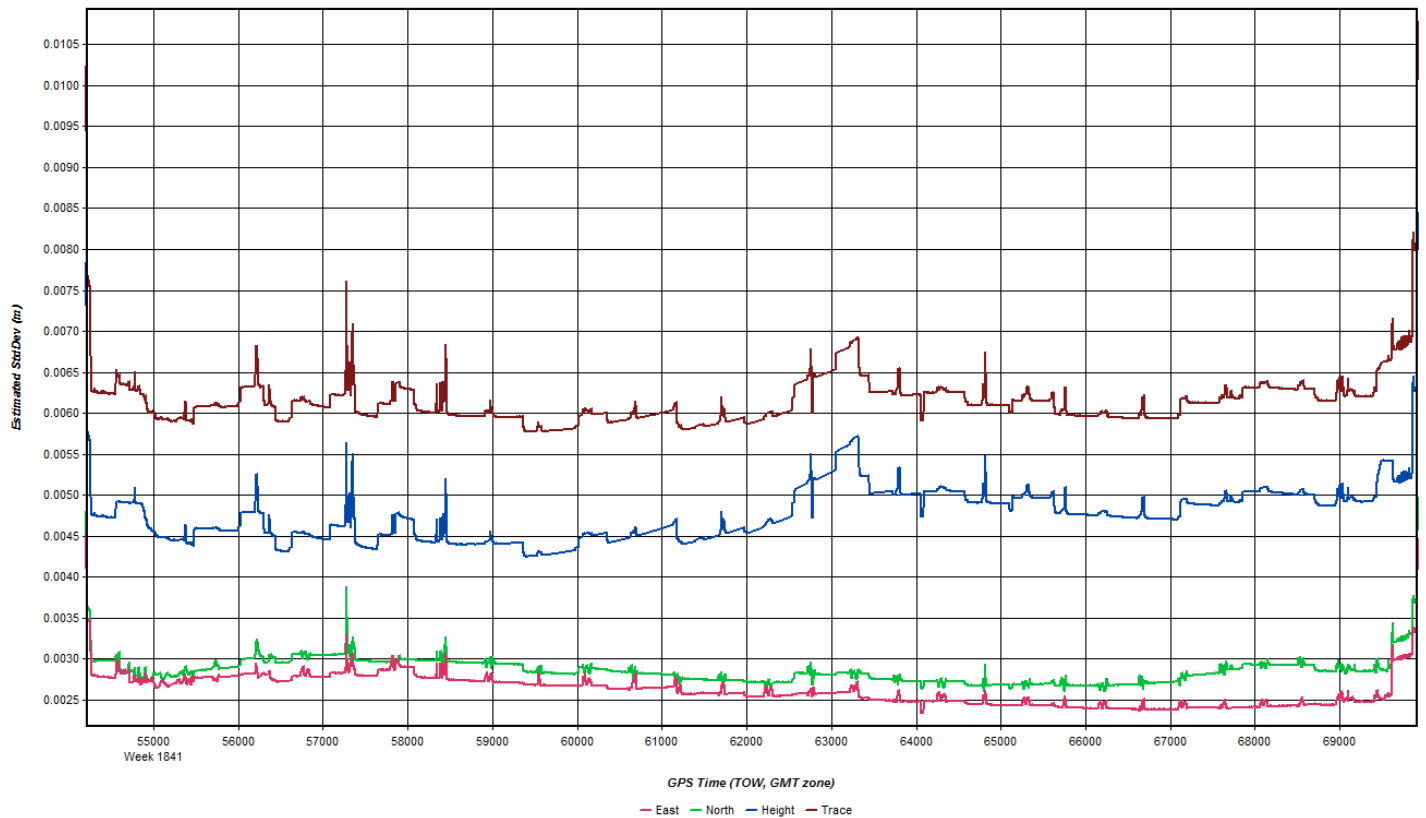
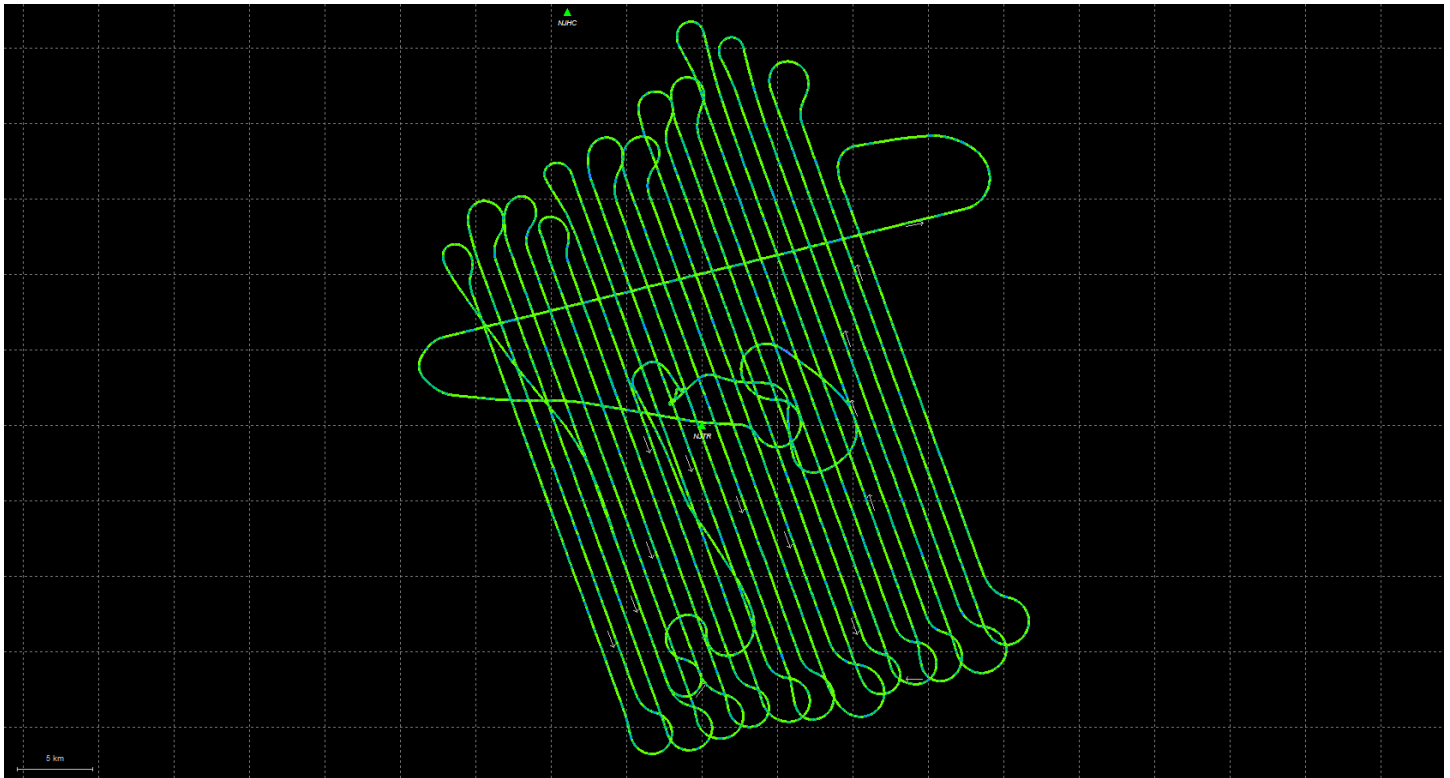

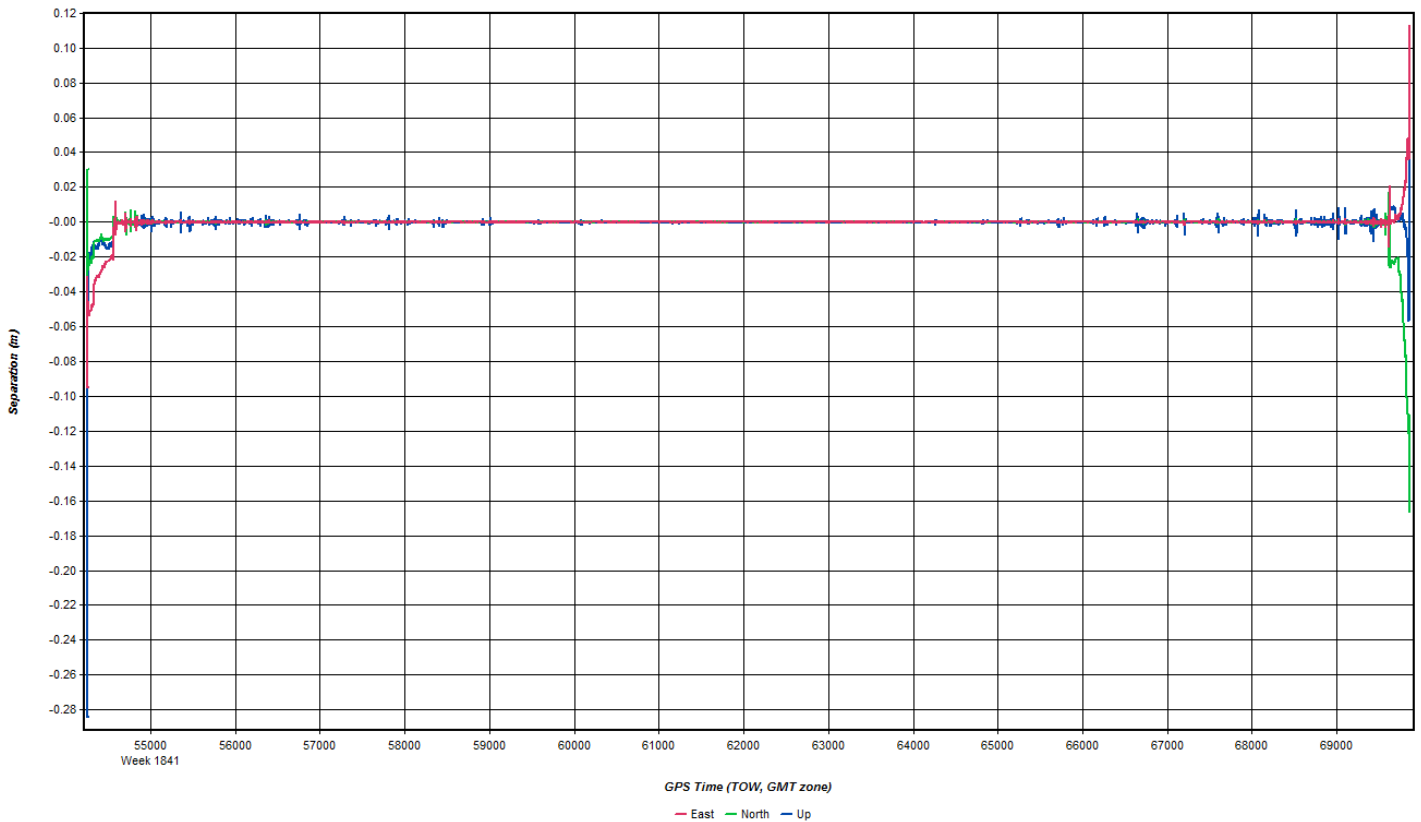
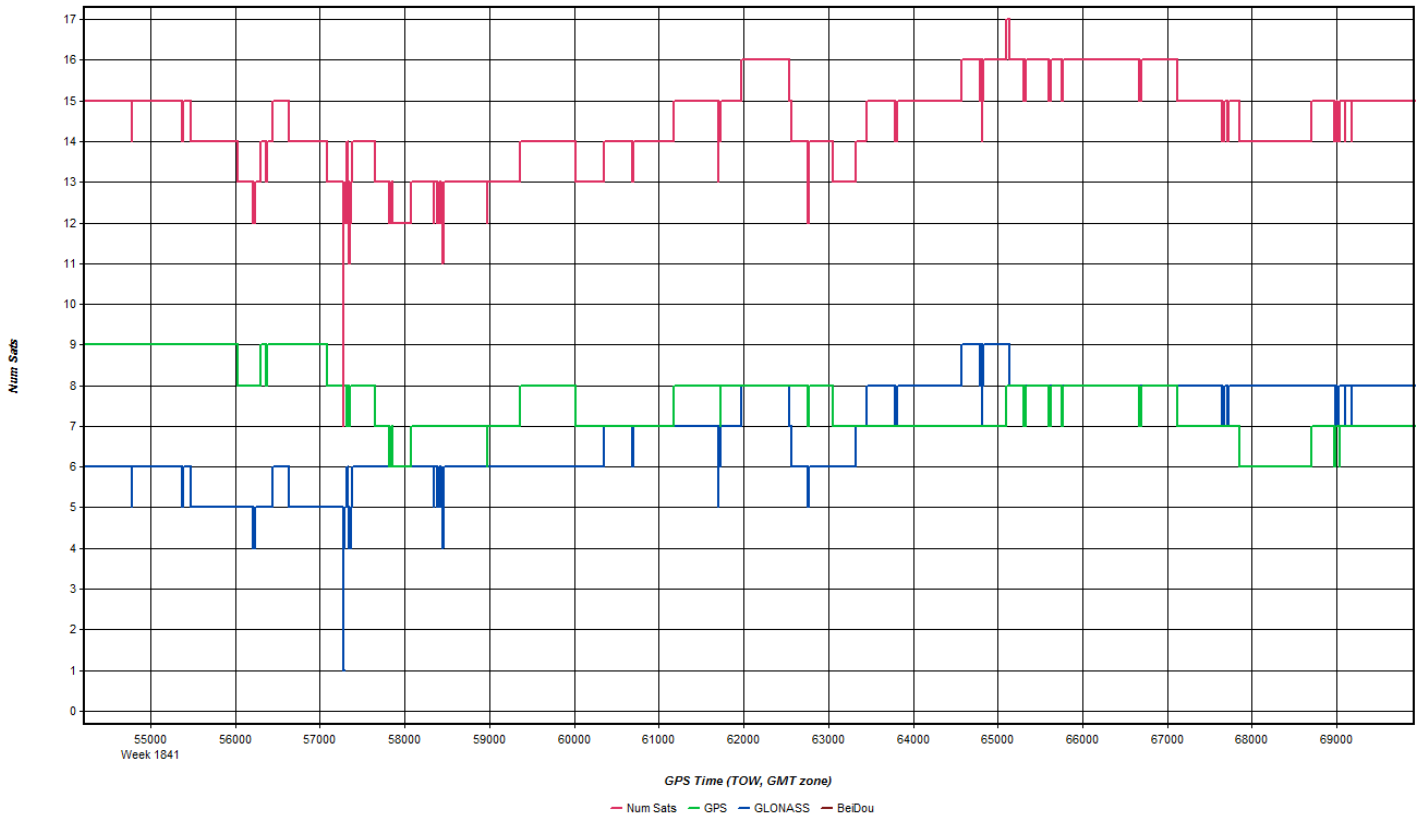

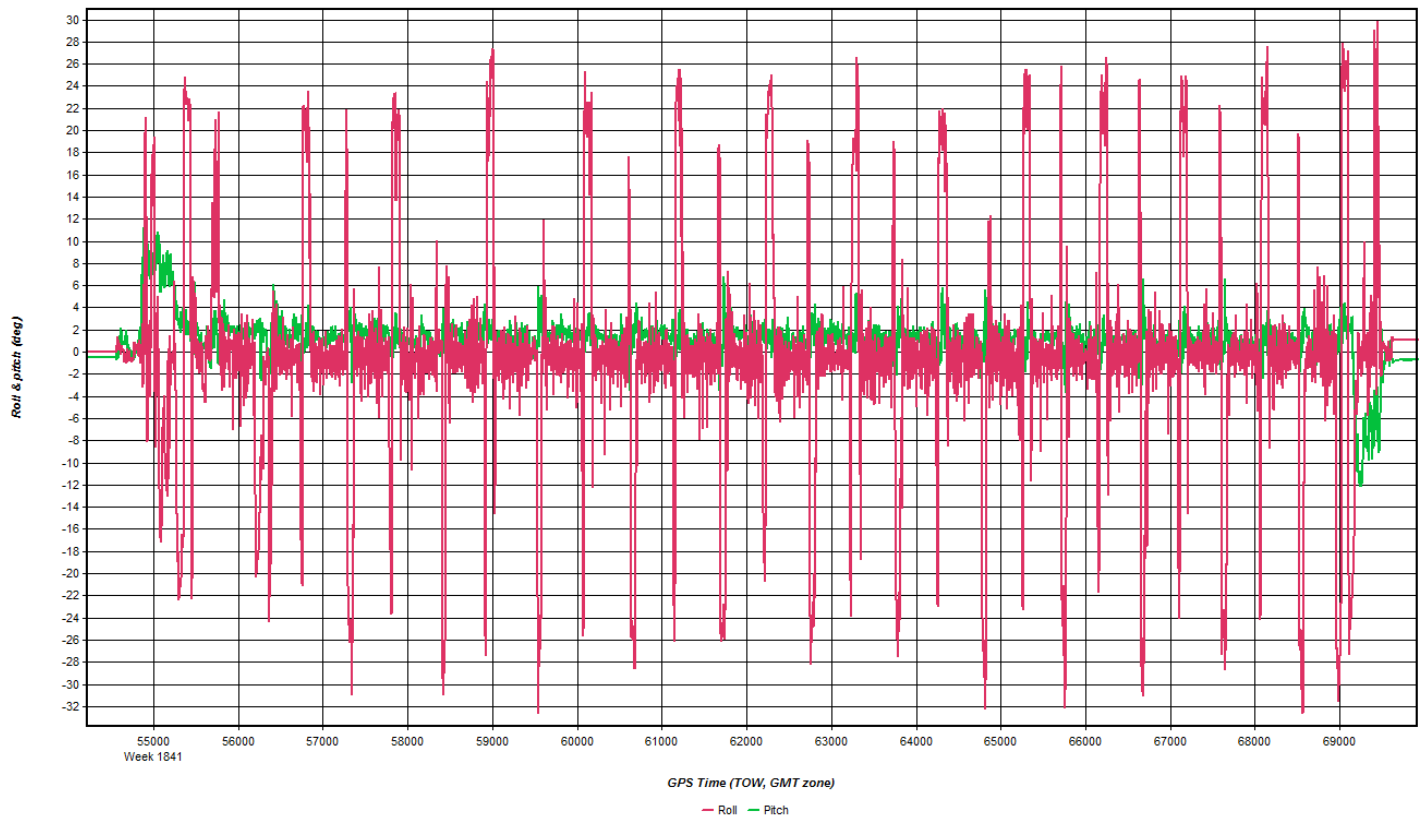
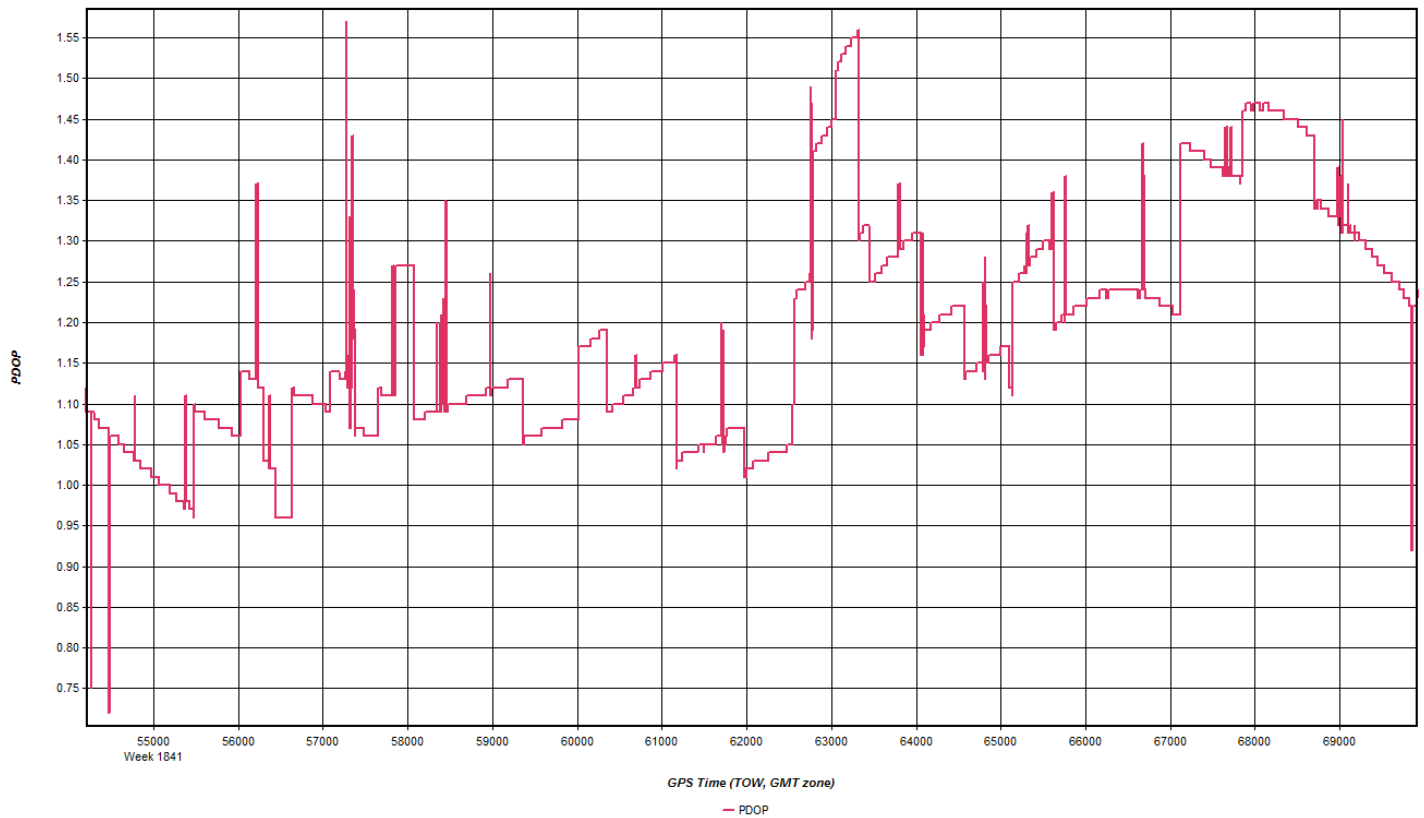

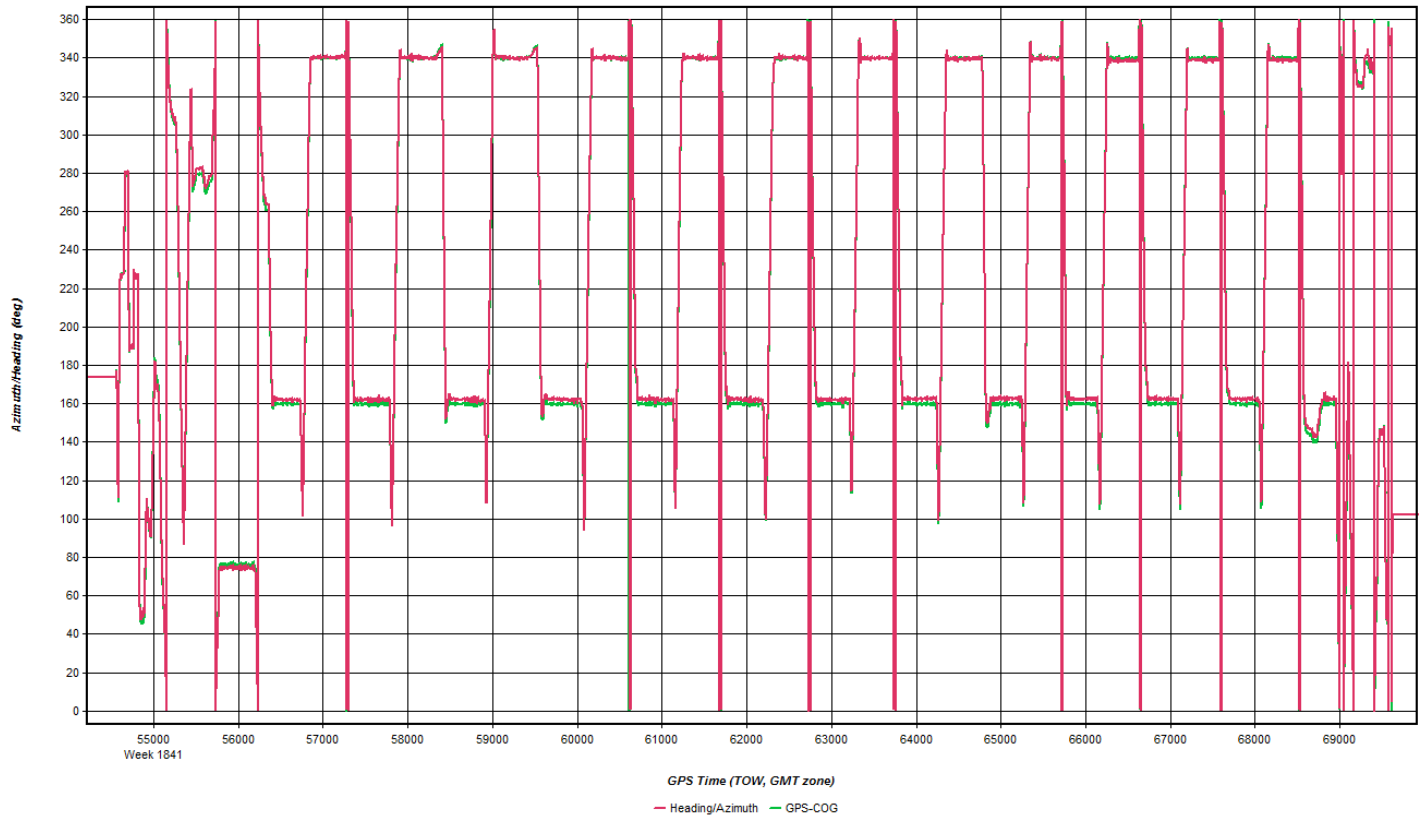

**Coordinate/Antenna Settings**

Master Remote

Base Station  
 Name: NJHC  Disabled  
 File: D:\Proc\26236\_DVRPC\NS6R\20150419\_150129\DVRPC\_N87

Coordinates  
 Latitude: North 40 30 05.80472   
 Longitude: West 74 54 04.01548   
 Ellipsoidal height: 95.918 m   
 Datum: NAD83(2011)

Antenna Height  
 From station file: LEIAT504GG, LEIS   
 Antenna profile: LEIAT504GG, LEIS   
 Measured height: 0.000 m  ARP  L1 Phase Centre  
 ARP to L1 offset: 0.087 m   
 Applied height: 0.087 m

Coordinate/Antenna Settings

Master Remote

Base Station  
1: NJTR Name: NJTR  Disabled  
File: D:\Proc\26236\_DVRPC\NS6R\20150419\_150129\DVRPC\_N87

Coordinates  
Latitude: North 40 15 27.46254   
Longitude: West 74 47 48.07181   
Ellipsoidal height: 41.271 m   
Datum: NAD83(2011)

Antenna Height  
From station file: LEIAR10, NONE   
Antenna profile: LEIAR10   
Measured height: 0.000 m  
ARP to L1 offset: 0.089 m  
Applied height: 0.089 m  
Measured to:  
 ARP  
 L1 Phase Centre

OK Cancel

# Flight Log



8255.0 → 8259.1 → 8259.3

**OPERATORS FLIGHT LOG**

YYYYMMDD\_TIME(GPS)

MISSION: S 0565 DWRK Q12		DATE: 4/19/15 b		LEICA ALS-70							
PILOT: Yours		OPERATOR: Rolfe		AIRCRAFT: N22GE							
PROJECT NUMBER	LINE NO. & Hdg	GND SPEED (KTS)	FREQ Hz	SCAN ANGLE	PRF KHZ	FIXED GAIN	ALT (m)	TIME START	TIME STOP	MM70 DRIVE	REMARKS
26236								15:03	15:08		Static Start
								15:14			T/O
	3037	89	52	40	352	N/A	7.4K	15:29	15:36		Figure 8 @ 15:21
	3024	173					7.5K	15:40	15:45		
	3023	353						15:47	15:53		
	3022	173						15:56	16:02		
	3021	353						16:05	16:12		
	3010	173						16:15	16:21		
	3019	353						16:23	16:30		
	3018	173						16:34	16:41		
	3017	353						16:43	16:50		
	3016	173						16:52	16:58		
	3015	353						17:00	17:07		
	3014	173					7.9K	17:10	17:16		
	3013	353					7.3K	17:19	17:25		
	3012	173						17:27	17:33		
	3011	353					7.4K	17:35	17:41		
	3010	173						17:44	17:50		
	3009	353						17:53	17:58		
	<b>TOTAL LINES</b>	<b>FLOWN</b>	<b>LEFT</b>	<b>SITE</b>	<b>AIRCRAFT FERRY</b>	<b>STATIC</b>	<b>START</b>	<b>STOP</b>	<b>NOTES:</b>		
○	26236	25	9	3.7	0.6	✓	15:03	19:25			
○						WAX					
○											

AERO-METRIC, INC. N.6216 Resource Drive Sheboygan Falls, WI. 53085 PHONE: 920-467-2655 FAX: 888-253-6695 E-Mail: amphoto@aerometric.com



**Apr 22, 2015-A  
(N269JE, SN7234)**

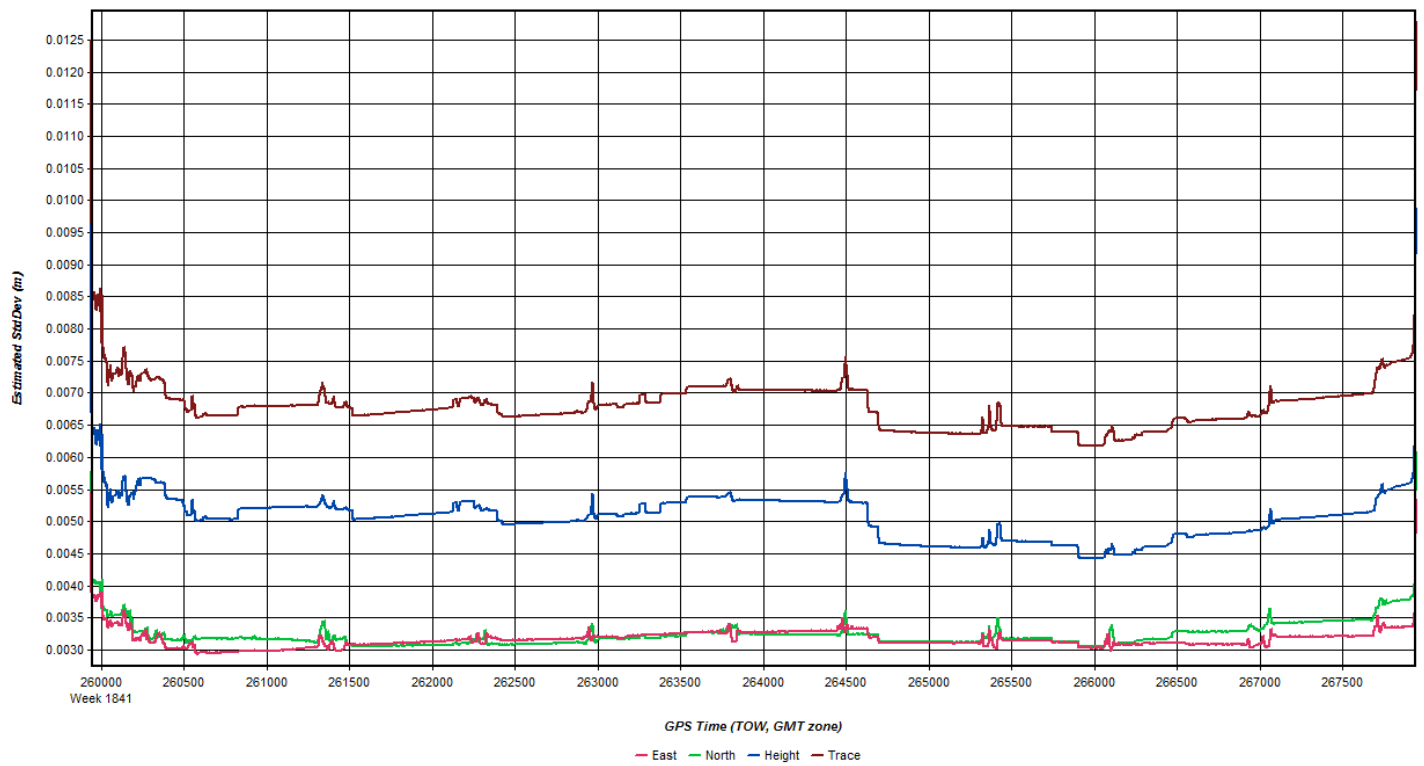
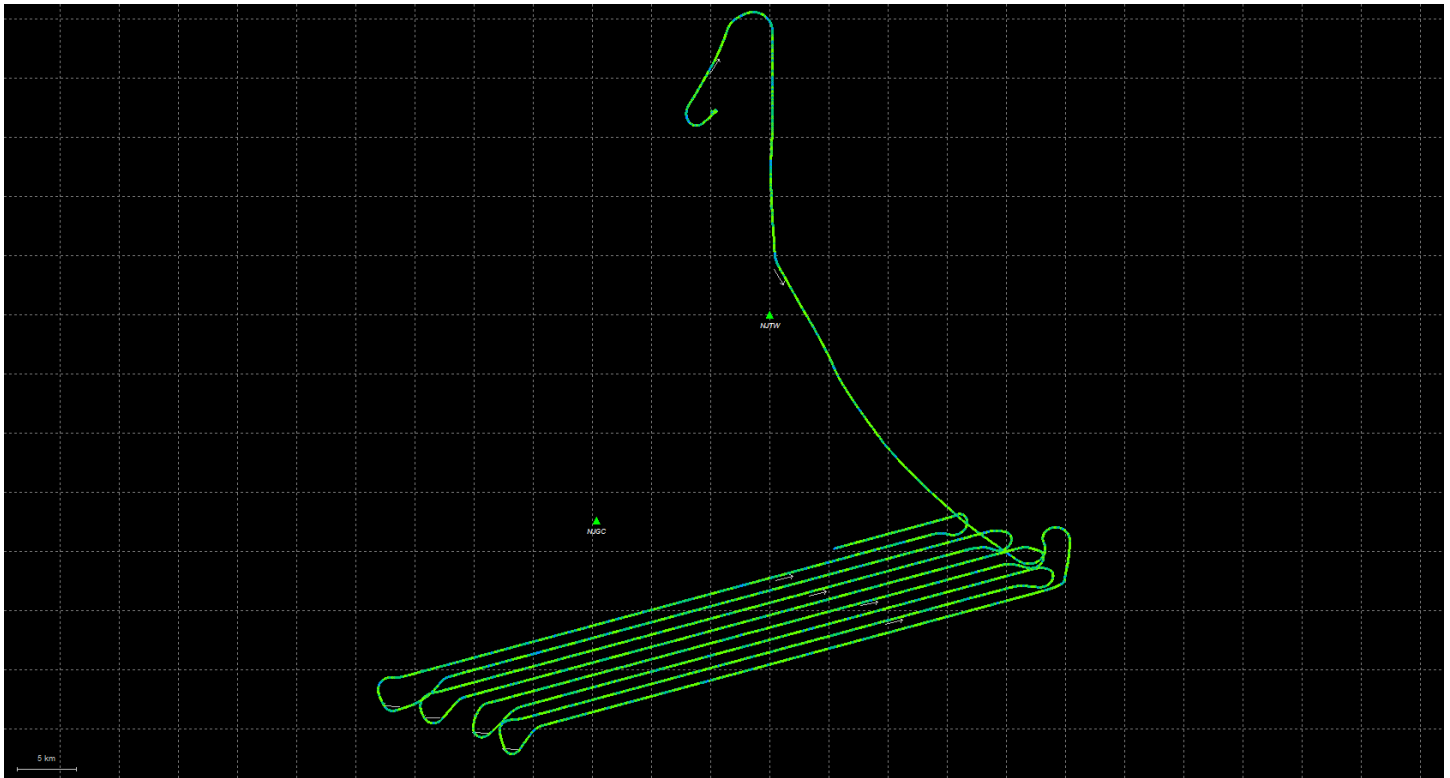

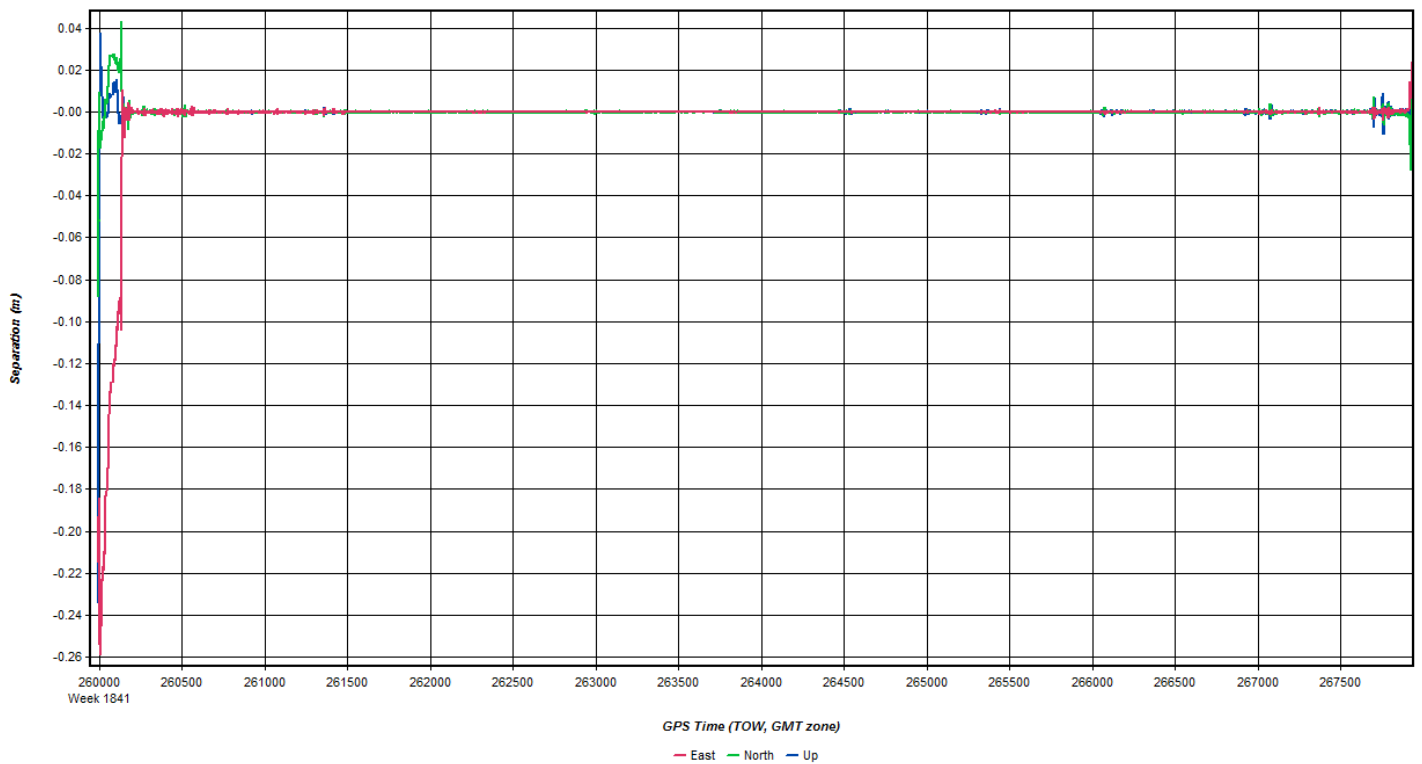
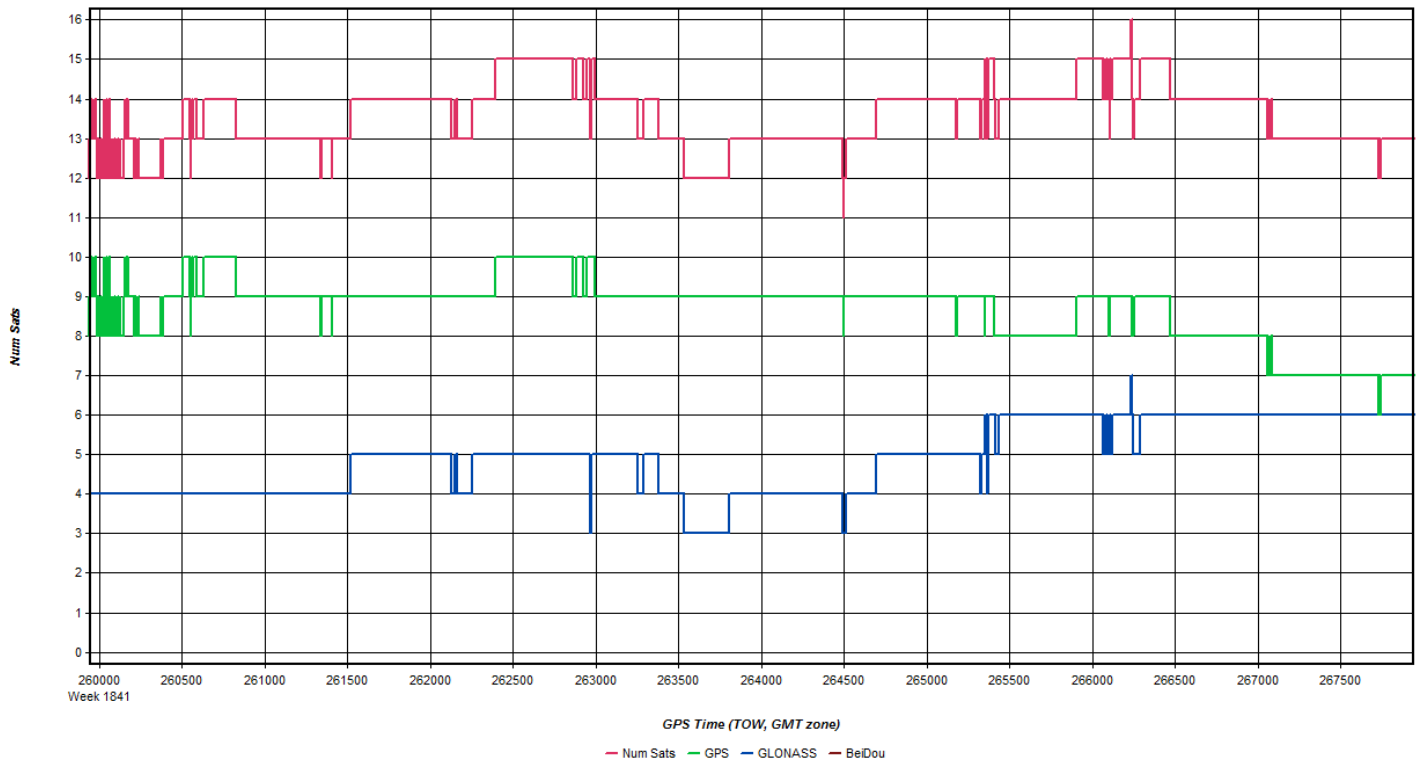

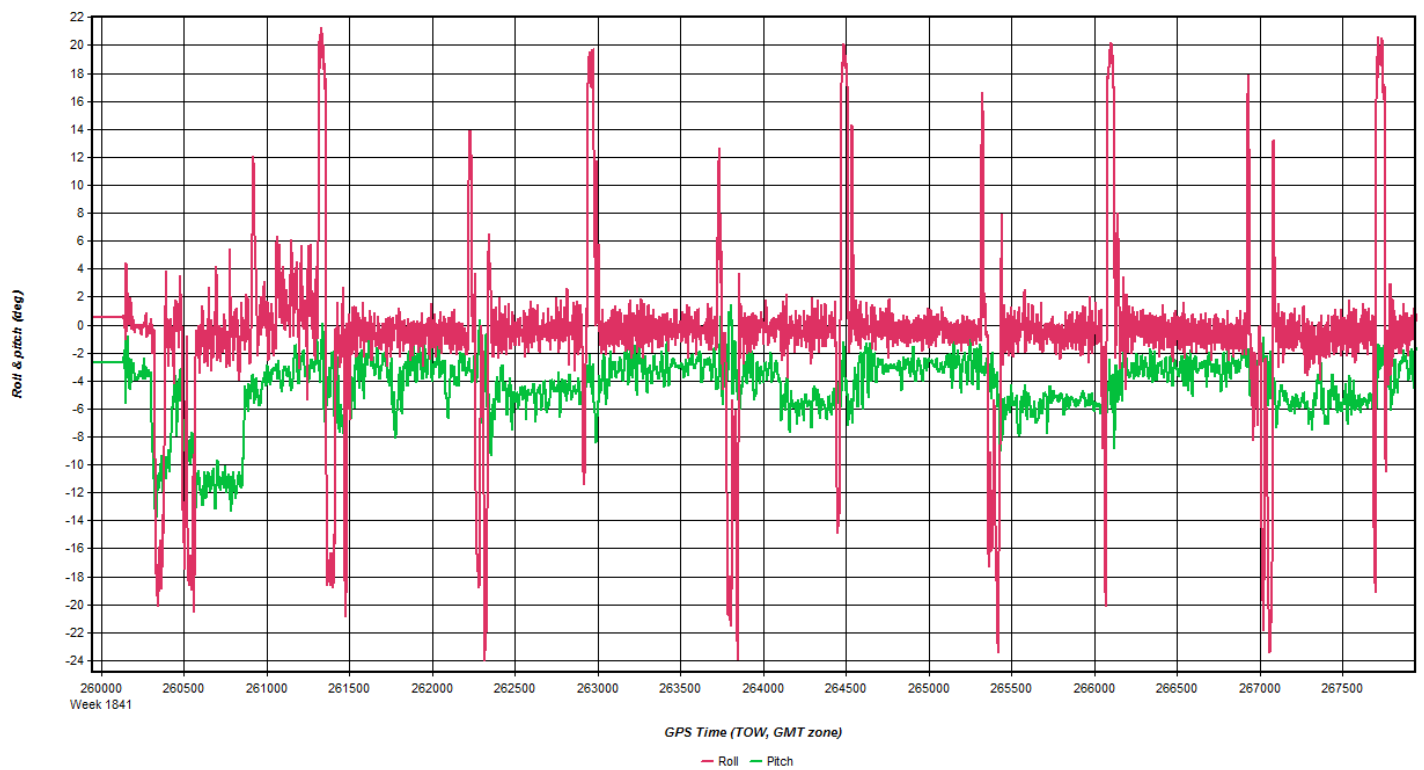

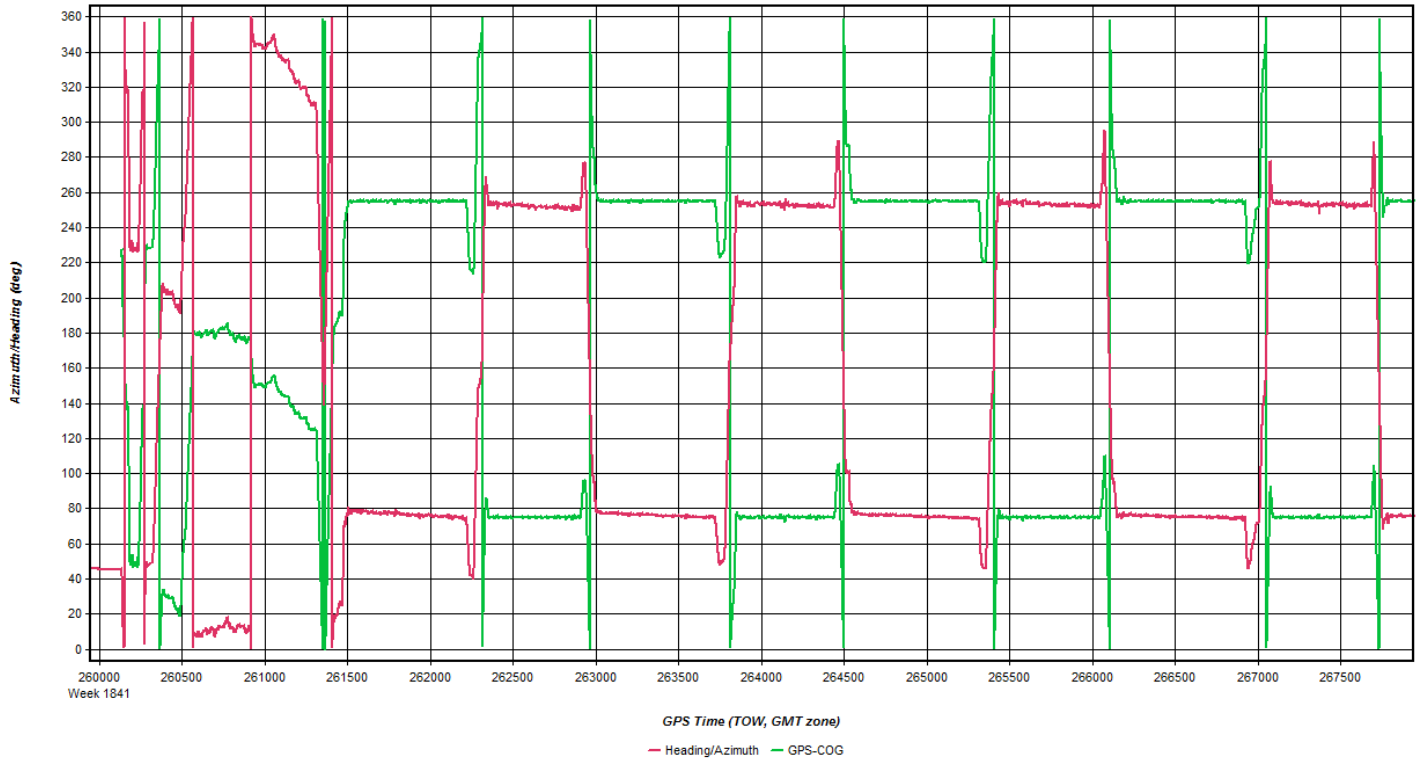

**Coordinate/Antenna Settings**

Master Remote

Base Station  
 2: NJGC Name: NJGC  Disabled  
 File: D:\Proc\26236\_DVRPC\K3D1\20150422A\_000622\DVRPC\_17

Coordinates  
 Latitude: North 39 46 52.79148   
 Longitude: West 75 07 11.25002   
 Ellipsoidal height: -3.994 m   
 Datum: NAD83(2011)

Antenna Height  
 From station file: LEIAR10, NONE   
 Antenna profile: LEIAR10   
 Measured height: 0.000 m  
 ARP to L1 offset: 0.089 m  
 Applied height: 0.089 m  
 Measured to:  
 ARP  
 L1 Phase Centre

Coordinate/Antenna Settings

Master Remote

Base Station  
1: NJTW Name: NJTW  Disabled  
File: D:\Proc\26236\_DVRPC\K3D1\20150422A\_000622\DVRPC\_17

Coordinates  
Latitude: North 39 56 11.04331   
Longitude: West 74 56 58.71204   
Ellipsoidal height: -20.002 m   
Datum: NAD83(2011)

Antenna Height  
From station file: TRM41249.00, NONE   
Antenna profile: TRM41249.00   
Measured height: 0.046 m  
ARP to L1 offset: 0.056 m  
Applied height: 0.102 m  
Measured to:  
 ARP  
 L1 Phase Centre



# Flight Log

## DVRPC 17N Cross Keys SN7234 QL2



QSI Project #	26236
Sensor Name	ALS70 SN7234
Flight Plan Style	Fixed MSL
Project Point Density (pts/m <sup>2</sup> )	2

Flight Plan Settings	
DEM Used for Planning	SRTM 30m
Target Speed (kts)	150
Max Bank Angle in Turns (°)	30
Minimum Line Overlap (%)	30
Pulses in Air Mode	MP/A
Scan Pattern	Triangle
Fixed Gain	255
Roll Comp. (ON/OFF)	N/A
Allowed vertical deviation (m)	

	Min.	Max
AGL (m) varies by line	2000	2000
MSL (ft) varies by line	6398	6532
FOV Range (°)	40.0	40.0
Scan Rate (Hz)	53.4	53.4
Swath Width (m)	1456	1456
Laser Power (%)	100	100
Pulse Rate (Hz)	273000	2732000

\*Shading = Auto-calculated

### Other Acquisition Notes:

Lines should be flown at the altitude (in FEET above sea level) indicated on the flight sheet. Give this number to the pilot for each line and have him use the altimeter on his instrument panel. The plane's altimeter is adjusted for pressure. Please note that each line is at a different altitude.

Project Flight Time Estimate	
Total Line Length (nmi)	762
Total Line Time (hrs, no buffer)	5.1
Total Number of Lines	46
Turn Time (min)	4
Total Turn Time (hrs, no buffer)	3.0667
Buffer (%)	10
MOB Dist. Round Trip (nmi)	60
Number of MOBs	2
Total Acquisition Time (hrs)	9.8

Mission Flight Time Estimate	
Start Line Name	1001
Stop Line Name	1042
Turn Time (min)	4
Buffer (%)	10
Acquisition Time (hrs)	#N/A

Line Name	Total Line Length [nm]	Flying Altitude [ft MSL]	Time Stamp	Refly Time Stamp	Sats./P DOP	Notes (Direction, Atmospheric Conditions, Speed, PR, Errors, etc.)
7001	10	6401	055735		17/1.1	
7002	11	6398	055008		18/1.0	
7003	12	6417	054352		19/1.0	
7004	13	6421	053533		20/0.9	
7005	19	6424	052636		20/1.1	
7006	19	6417	051429		18/1.2	
7007	20	6426	050503		18/1.2	
7008	21	6424	045206		19/1.1	
7009	21	6423	044208		19/1.1	
7010	21	6434	043024		19/1.0	
7011	22	6434	041919		19/1.1	
7012	23	6434	040452		19/1.1	
7013	23	6427	035327		20/1.1	
7014	23	6459	033834		20/1.1	
7015	23	6450	032658		20/1.1	
7016	24	6453	031214		17/1.3	
7017	24	6456	025938		17/1.2	
7018	24	6480	022287		18/1.1	Shutter opened through external control @ end of line
7019	24	6489	021125		18/1.1	full restart required
7020	23	6521	015631		19/1.1	
7021	24	6519	014400		19/1.1	
7022	24	6495	012945		17/1.2	
7023	23	6495	011741		18/1.2	
7024	22	6489	010356		18/1.4	
7025	22	6482	005228		18/1.4	
7026	21	6486	003911		18/1.1	
7027	20	6489				
7028	19	6489				
7029	18	6495				
7030	17	6506				
7031	16	6516				
7032	14	6516				



# Base Station Log

### GPS OBSERVATION LOG

Station ID	<u>17N</u>	Date	<u>04 / 21 / 2015</u>
Project Number	<u>26236</u>	Julian Date	<u>112</u>
Project Name	<u>USGS_DVRPC_012</u>	Start Time	<u>02:51:00 PM</u>
Rcvr. Type	<u>Novatel DLV3 L1 L2</u>	Stop Time	<u>02:43:00 AM 4/22</u>
Rcvr. S/N	<u>Z-0141418</u>	Rcvr. File Name	<u>00081110.PDC</u>
Antenna Type	<u>Novatel 1.03 HW Rev</u>	Observer	<u>Charlie Onega</u>
Antenna S/N	<u>01017577</u>		

New or Existing

Mon.  New

Existing

Photo Taken:

Yes  No

Monument Type:

Spike  PK Nail

AM Washer

Other

Monument set by Mike Aust, Revised

Height Readings:

(Top of Monument to Bottom of Ground Plane)

Start	<u>1.5</u>	M.	Ft.
Stop	<u>1.5</u>	M.	Ft.
Mean		M.	Ft.

Monument Sketch and Notes:

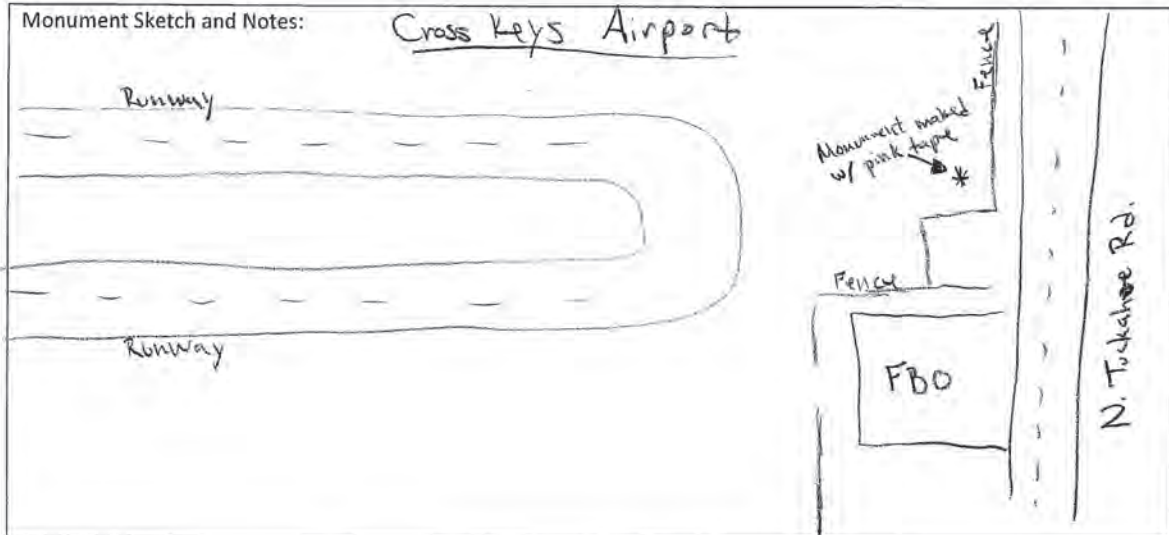

**Apr 22, 2015-B  
(N269JE, SN7234)**

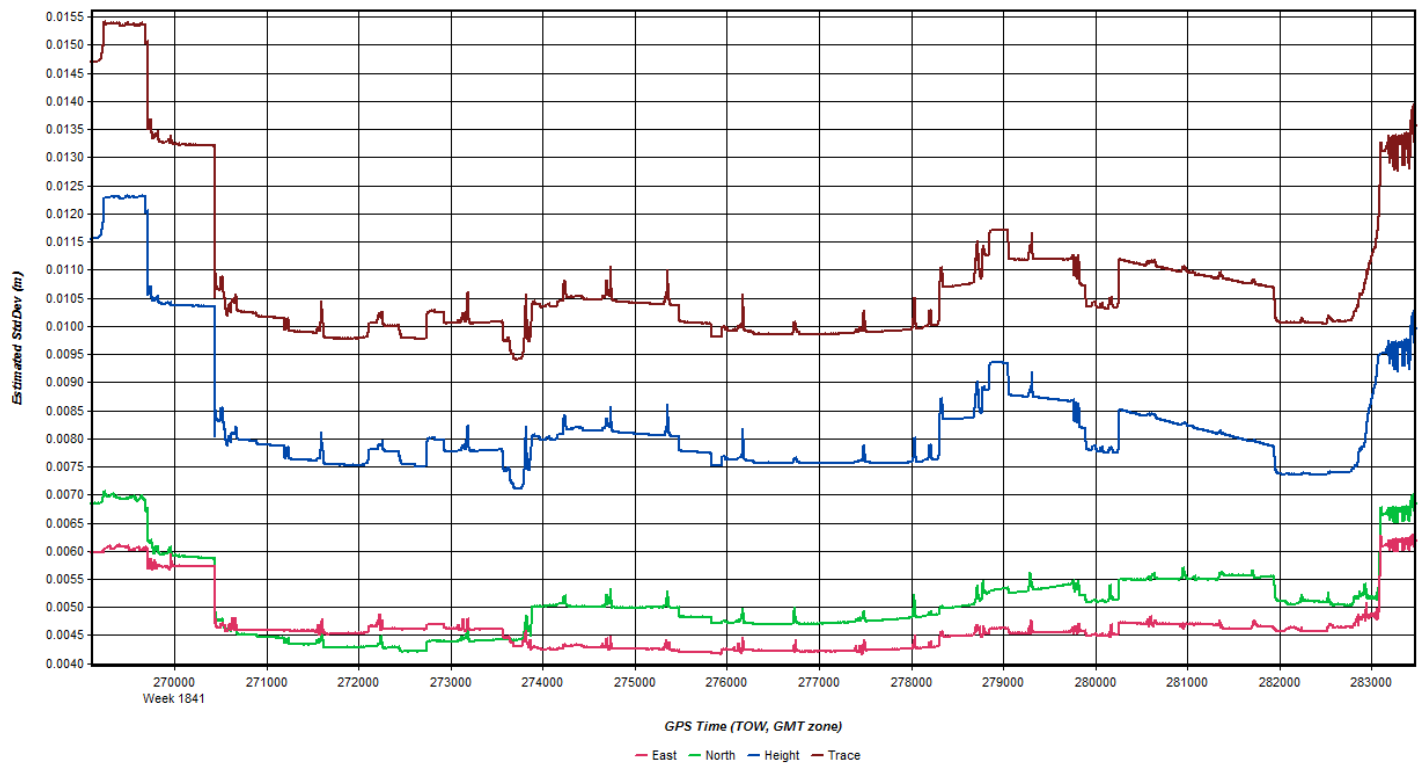
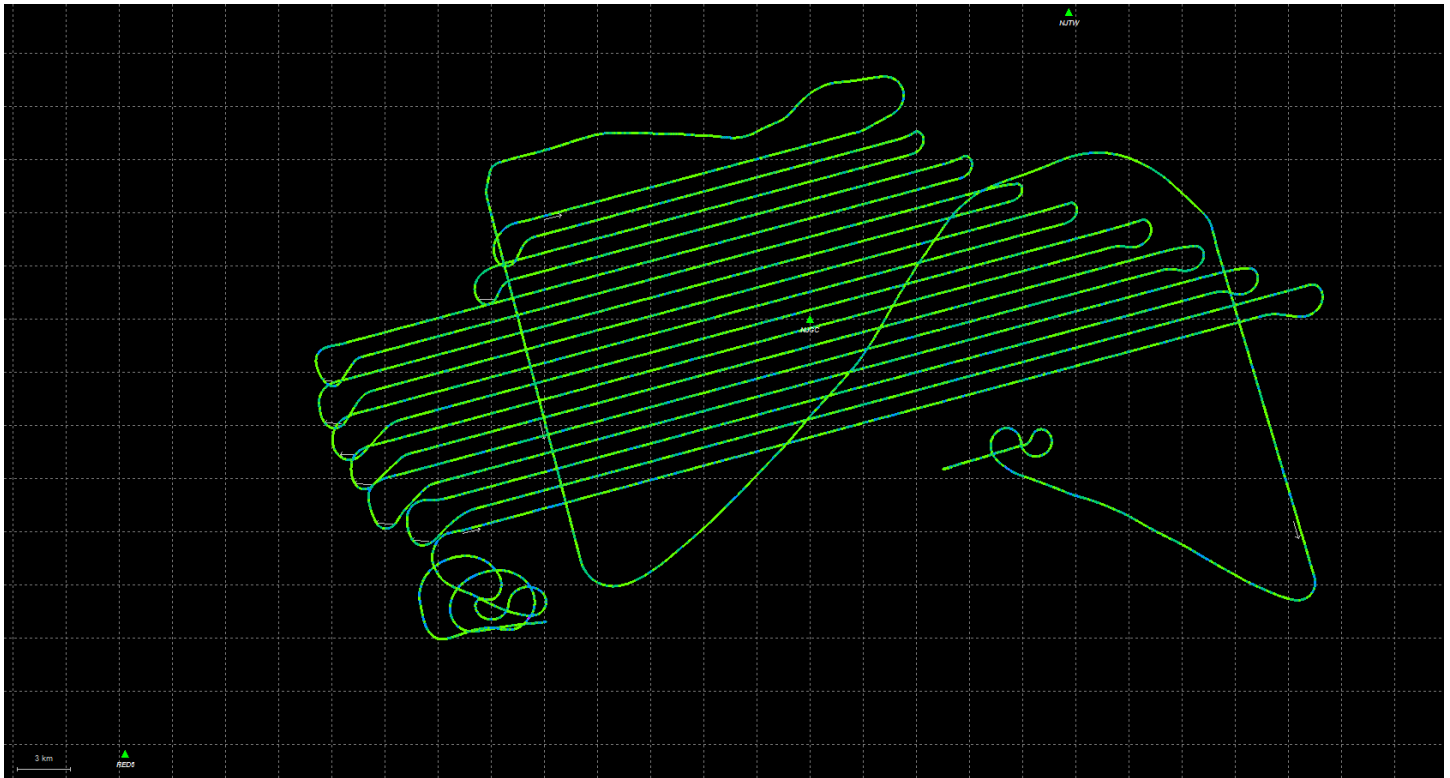



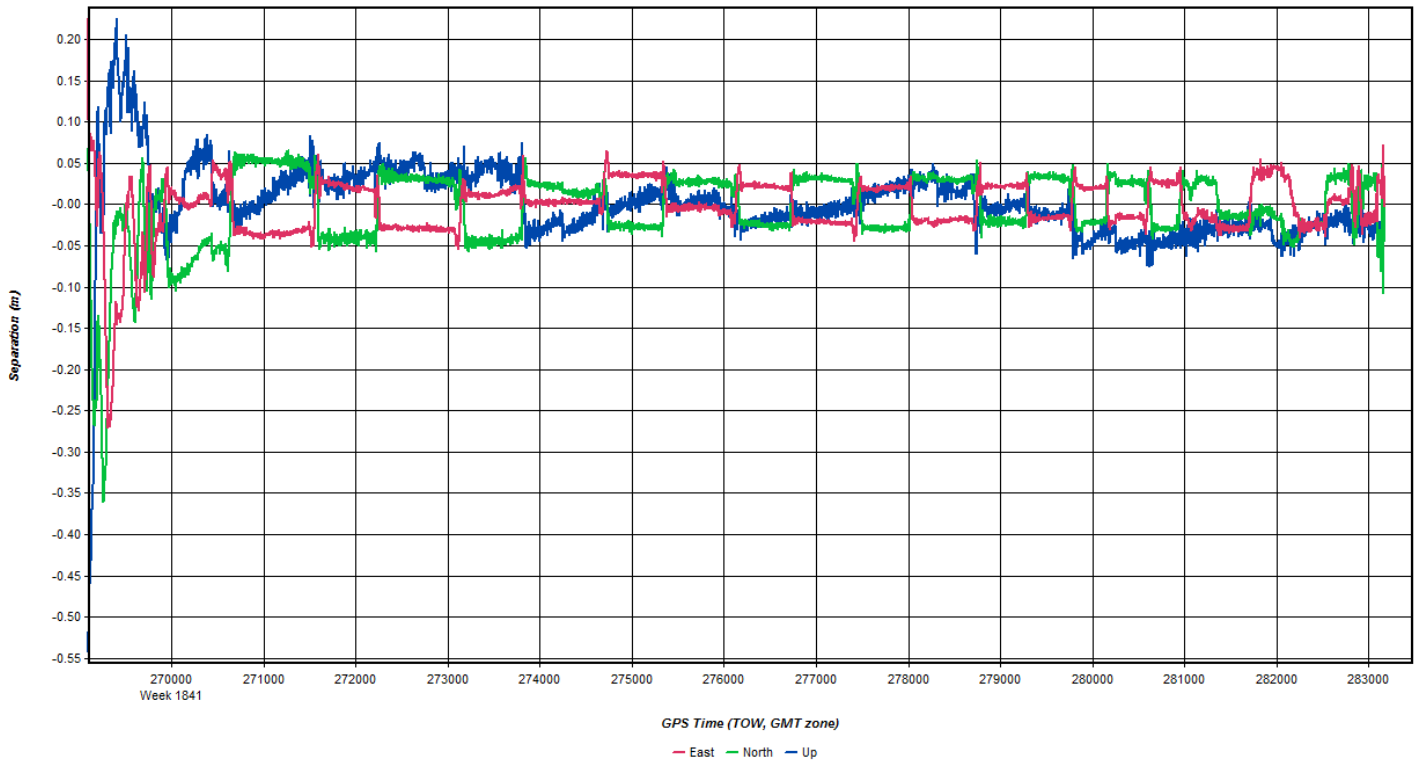
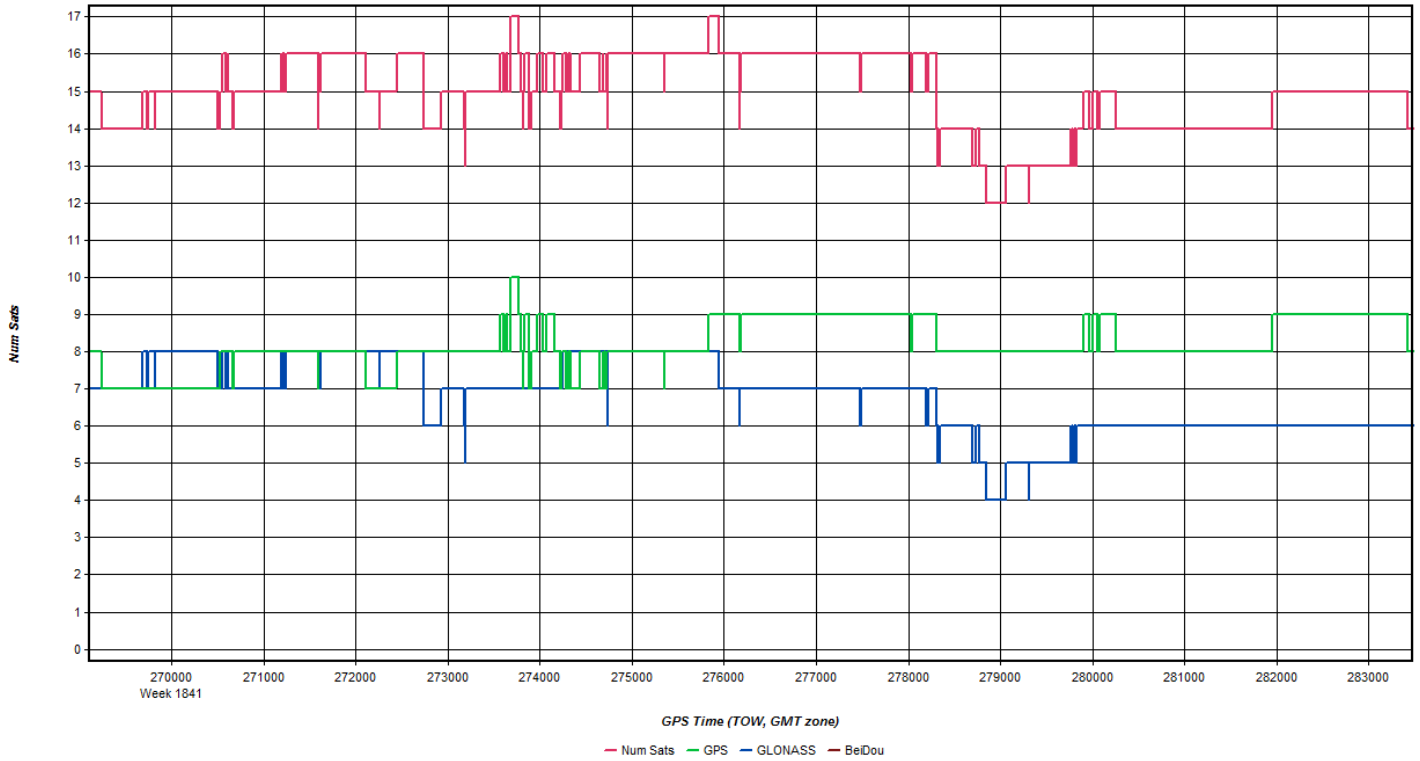

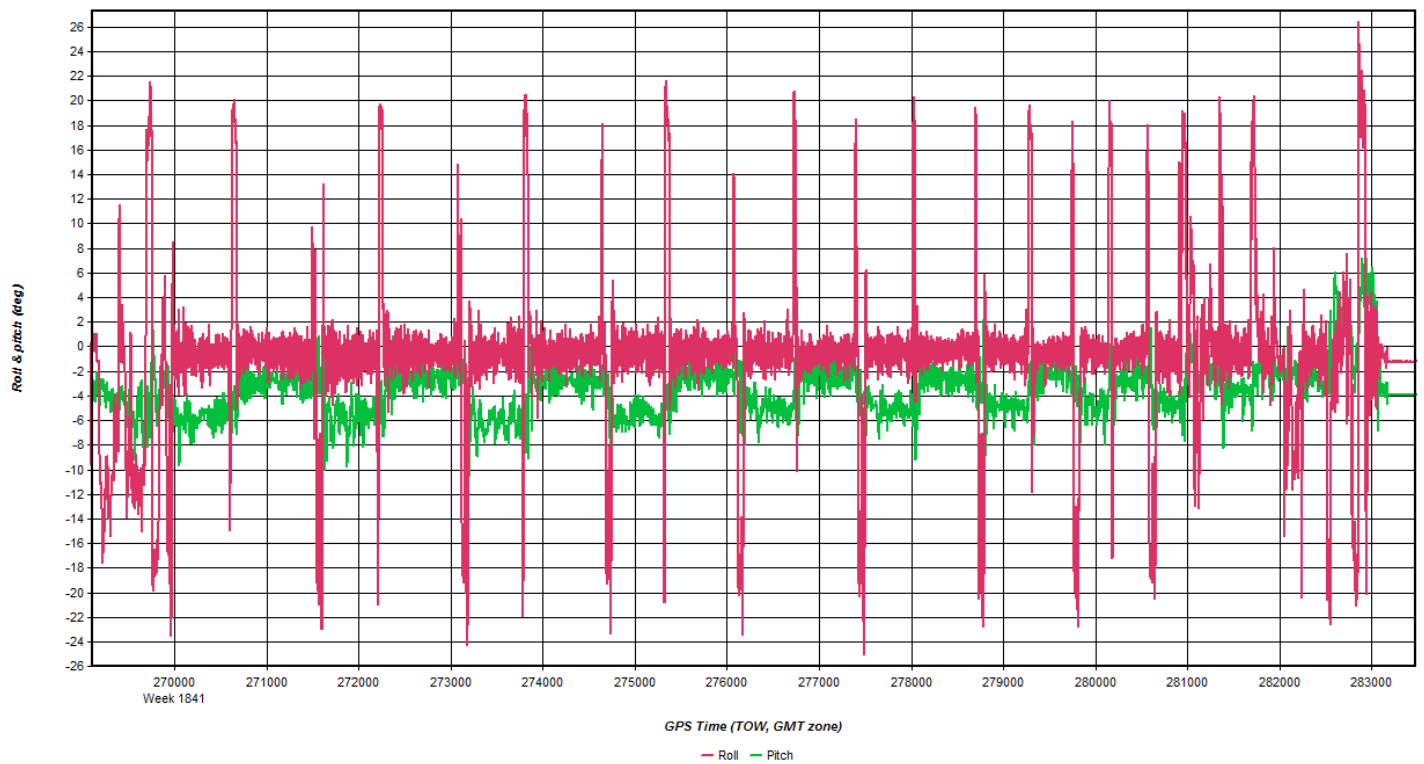
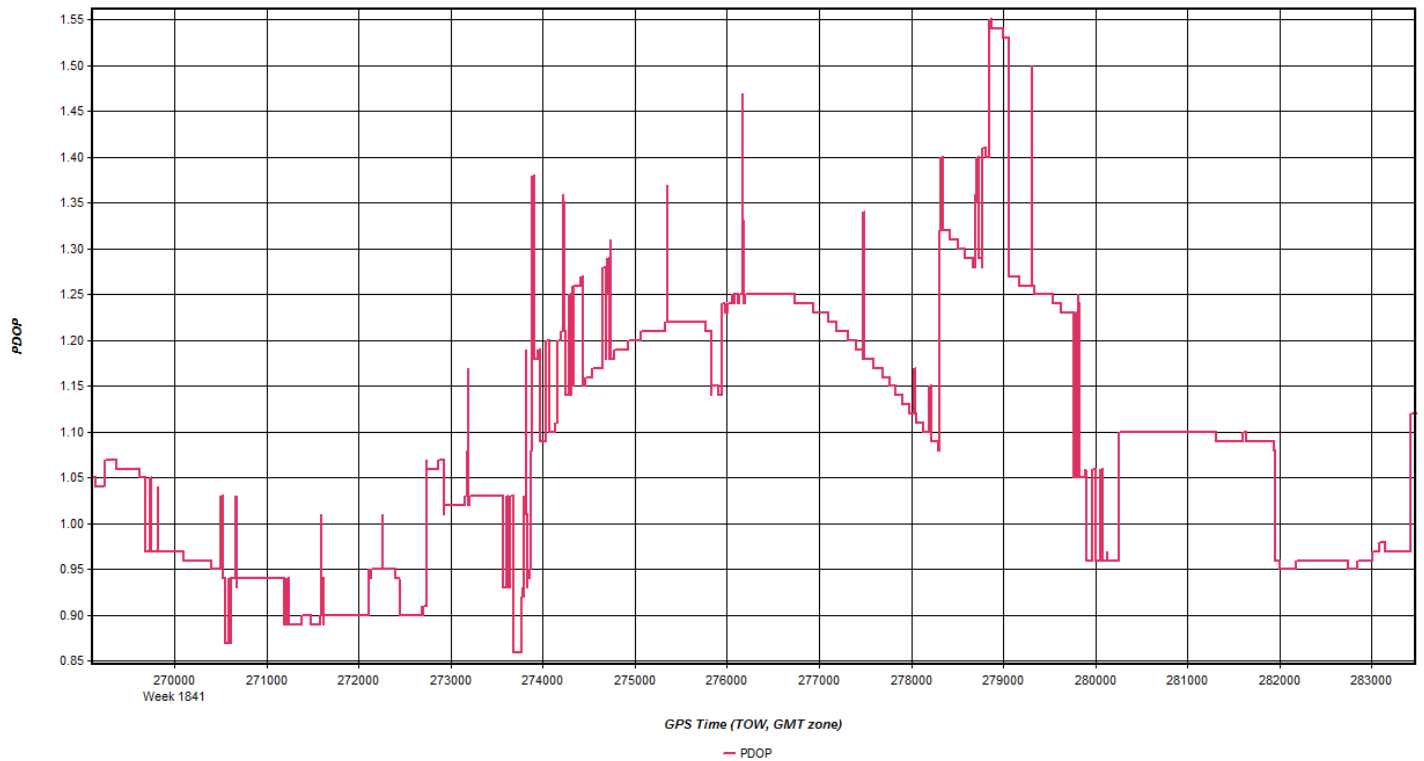

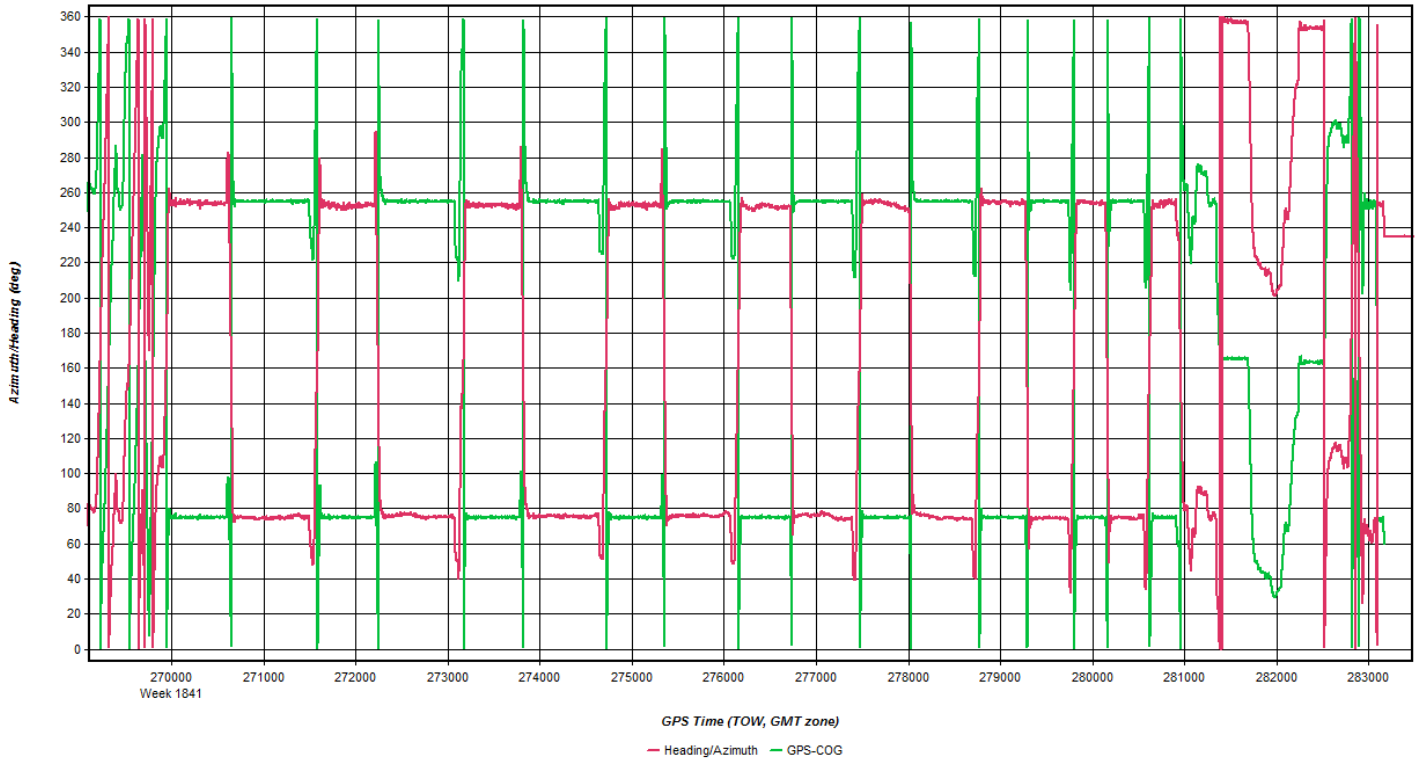

**Coordinate/Antenna Settings**

Master Remote

Base Station  
 1: NJGC Name: NJGC  Disabled  
 File: D:\Proc\26236\_DVRPC\K3D1\20150422B\_024130\DVRPC\_17

Coordinates  
 Latitude: North 39 46 52.79148   
 Longitude: West 75 07 11.25002   
 Ellipsoidal height: -3.994 m   
 Datum: NAD83(2011)

Antenna Height  
 From station file: LEIAR10, NONE   
 Antenna profile: LEIAR10   
 Measured height: 0.000 m  
 ARP to L1 offset: 0.089 m  
 Applied height: 0.089 m  
 Measured to:  
 ARP  
 L1 Phase Centre

Coordinate/Antenna Settings

Master Remote

Base Station  
 2: NJTW Name: NJTW  Disabled  
 File: D:\Proc\26236\_DVRPC\K3D1\20150422B\_024130\DVRPC\_17

Coordinates  
 Latitude: North 39 56 11.04331   
 Longitude: West 74 56 58.71204   
 Ellipsoidal height: -20.002 m   
 Datum: NAD83(2011)

Antenna Height  
 From station file: TRM41249.00, NONE   
 Antenna profile: TRM41249.00   
 Measured height: 0.046 m  
 ARP to L1 offset: 0.056 m  
 Applied height: 0.102 m  
 Measured to  
 ARP  
 L1 Phase Centre

Coordinate/Antenna Settings

Master Remote

Base Station  
 3: RED6 Name: RED6  Disabled  
 File: D:\Proc\26236\_DVRPC\K3D1\20150422B\_024130\DVRPC\_17

Coordinates  
 Latitude: North 39 33 42.03605   
 Longitude: West 75 34 11.82143   
 Ellipsoidal height: -25.942 m   
 Datum: NAD83(2011)

Antenna Height  
 From station file: TRM41249USCG, SCIT   
 Antenna profile: TRM41249USCG, SCIT   
 Measured height: 0.000 m  
 ARP to L1 offset: 0.063 m  
 Applied height: 0.063 m  
 Measured to  
 ARP  
 L1 Phase Centre

# Flight Log

## DVRPC 17N Cross Keys SN7234 QL2

QSI Project #	26236
Sensor Name	ALS70 SN7234
Flight Plan Style	Fixed MSL
Project Point Density (pts/m <sup>2</sup> )	2



Flight Plan Settings	
DEM Used for Planning	SRTM 30m
Target Speed (kts)	150
Max Bank Angle in Turns (°)	30
Minimum Line Overlap (%)	30
Pulses in Air Mode	MP/A
Scan Pattern	Triangle
Fixed Gain	255
Roll Comp. (ON/OFF)	N/A
Allowed vertical deviation (m)	

	Min.	Max
AGL (m) varies by line	2000	2000
MSL (ft) varies by line	6398	6532
FOV Range (°)	40.0	40.0
Scan Rate (Hz)	53.4	53.4
Swath Width (m)	1456	1456
Laser Power (%)	100	100
Pulse Rate (Hz)	273000	2732000

\*Shading = Auto-calculated

### Other Acquisition Notes:

Lines should be flown at the altitude (in FEET above sea level) indicated on the flight sheet. Give this number to the pilot for each line and have him use the altimeter on his instrument panel. The plane's altimeter is adjusted for pressure. Please note that each line is at a different altitude.

Project Flight Time Estimate	
Total Line Length (nmi)	762
Total Line Time (hrs, no buffer)	5.1
Total Number of Lines	46
Turn Time (min)	4
Total Turn Time (hrs, no buffer)	3.0667
Buffer (%)	10
MOB Dist. Round Trip (nmi)	60
Number of MOBs	2
Total Acquisition Time (hrs)	9.8

Mission Flight Time Estimate	
Start Line Name	1001
Stop Line Name	1042
Turn Time (min)	4
Buffer (%)	10
Acquisition Time (hrs)	#N/A

Line Name	Total Line Length [nm]	Flying Altitude [ft MSL]	Time Stamp	Refly Time Stamp	Sats./P DOP	Notes (Direction, Atmospheric Conditions, Speed, PR, Errors, etc.)
7001	10	6401	055735		17/1.1	
7002	11	6398	055008		18/1.0	
7003	12	6417	054352		19/1.0	
7004	13	6421	053533		20/0.9	
7005	19	6424	052636		20/1.1	
7006	19	6417	051429		18/1.2	
7007	20	6426	050503		18/1.2	
7008	21	6424	045206		19/1.1	
7009	21	6423	044208		19/1.1	
7010	21	6434	043024		19/1.1	
7011	22	6434	041919		19/1.0	
7012	23	6434	040452		19/1.1	
7013	23	6427	035327		20/1.1	
7014	23	6459	033834		20/1.1	
7015	23	6450	032658		20/1.1	
7016	24	6453	031214		17/1.3	
7017	24	6456	025938		17/1.2	
7018	24	6480	022287		18/1.1	Shutter opened through external control @ end of line
7019	24	6489	021125		18/1.1	full restart required
7020	23	6521	015631		19/1.1	
7021	24	6519	014400		19/1.1	
7022	24	6495	012945		17/1.2	
7023	23	6495	011741		18/1.2	
7024	22	6489	010356		18/1.4	
7025	22	6482	005228		18/1.4	
7026	21	6486	003911		18/1.1	
7027	20	6489				
7028	19	6489				
7029	18	6495				
7030	17	6506				
7031	16	6516				
7032	14	6516				

7033	13	6516						
7034	12	6515						
7035	11	6499						
7036	10	6483						
7037	9	6509						
7038	7	6526						
7039	6	6522						
7040	5	6532						
7041	4	6532						
7042	3	6532						
7043	1	6532						
7044	24	6417						
<del>7045</del>	9	6434	061031	10/12				
<del>7046</del>	9	6506	062430	10/13				



# Base Station Log

### GPS OBSERVATION LOG

Station ID	<u>17N</u>	Date	<u>04 / 21 / 2015</u>
Project Number	<u>26236</u>	Julian Date	<u>112</u>
Project Name	<u>USGS_DVRPC_012</u>	Start Time	<u>02:51:00 PM</u>
Rcvr. Type	<u>Novatel DLV3 L1 L2</u>	Stop Time	<u>02:43:00 AM 4/22</u>
Rcvr. S/N	<u>Z-0141418</u>	Rcvr. File Name	<u>00081110.PDC</u>
Antenna Type	<u>Novatel 1.03 HW Rev</u>	Observer	<u>Charlie Onega</u>
Antenna S/N	<u>0101 7577</u>		

New or Existing

Mon.  New

Existing

Photo Taken:

Yes  No

Monument Type:

Spike  PK Nail

AM Washer

Other

Monument set by Mike Aust, Revised

Height Readings:

(Top of Monument to Bottom of Ground Plane)

Start	<u>1.5</u>	M.	Ft.
Stop	<u>1.5</u>	M.	Ft.
Mean		M.	Ft.

Monument Sketch and Notes:

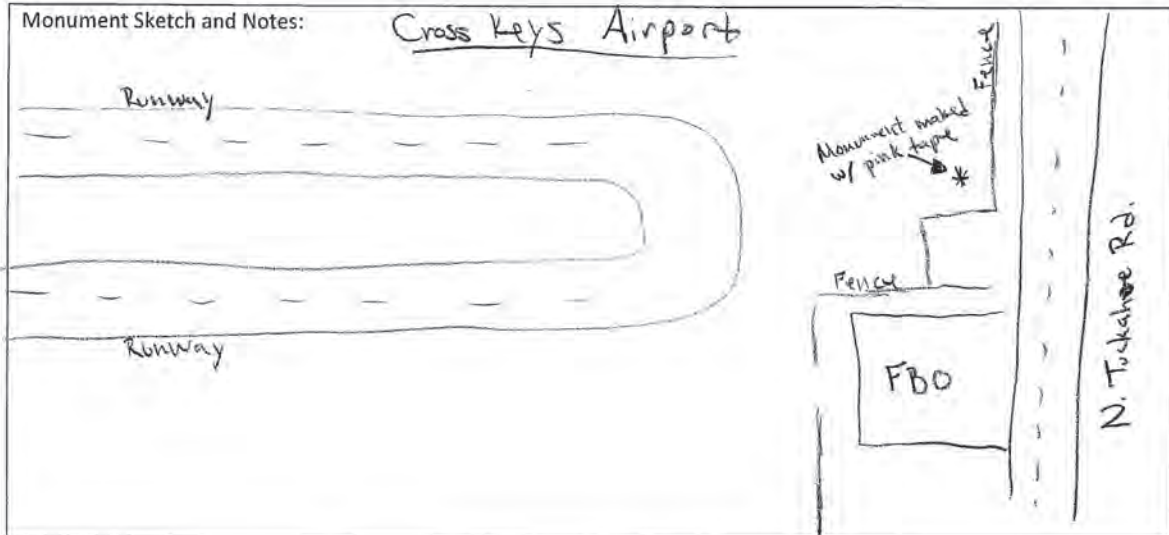

# Apr 24, 2015-A (N269JE, SN7234) CrossKeys and KWAY

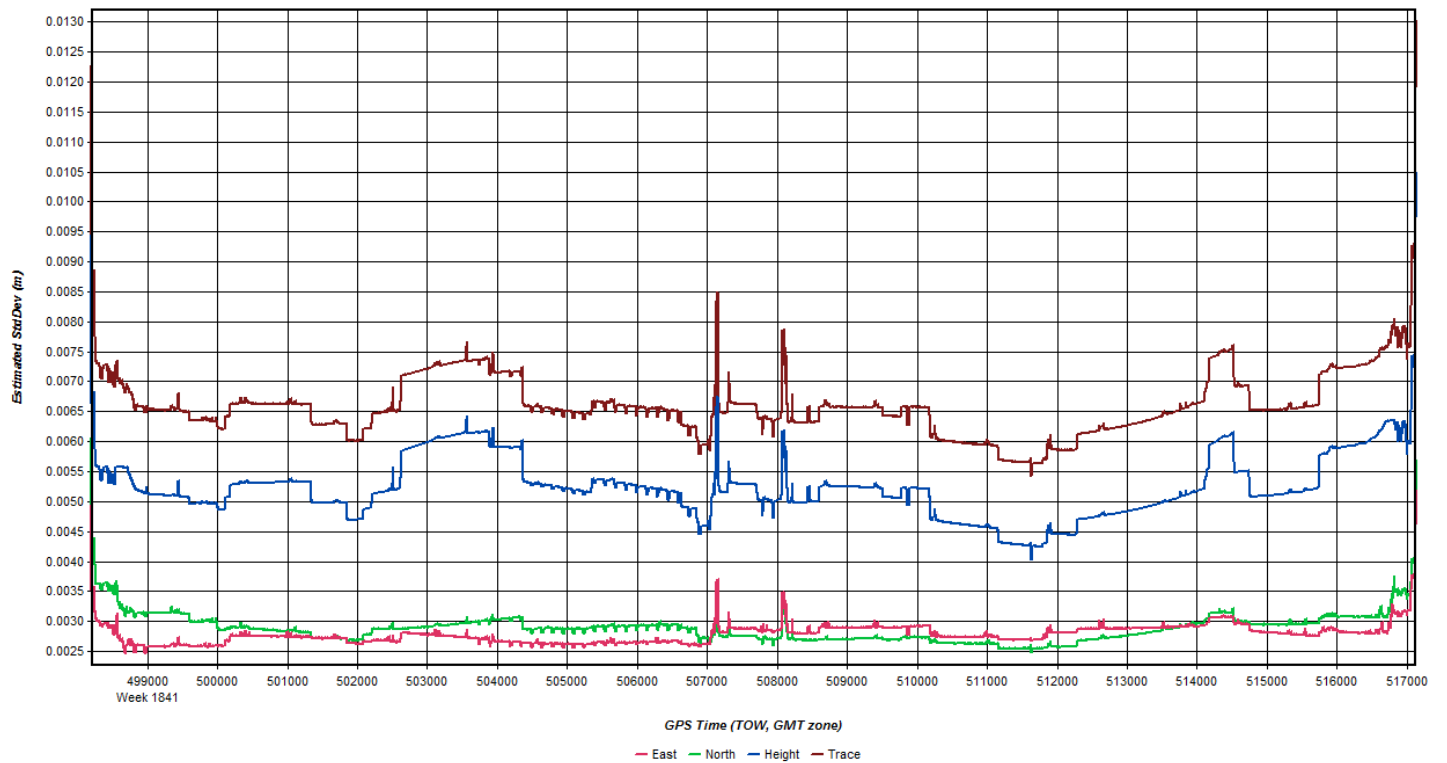
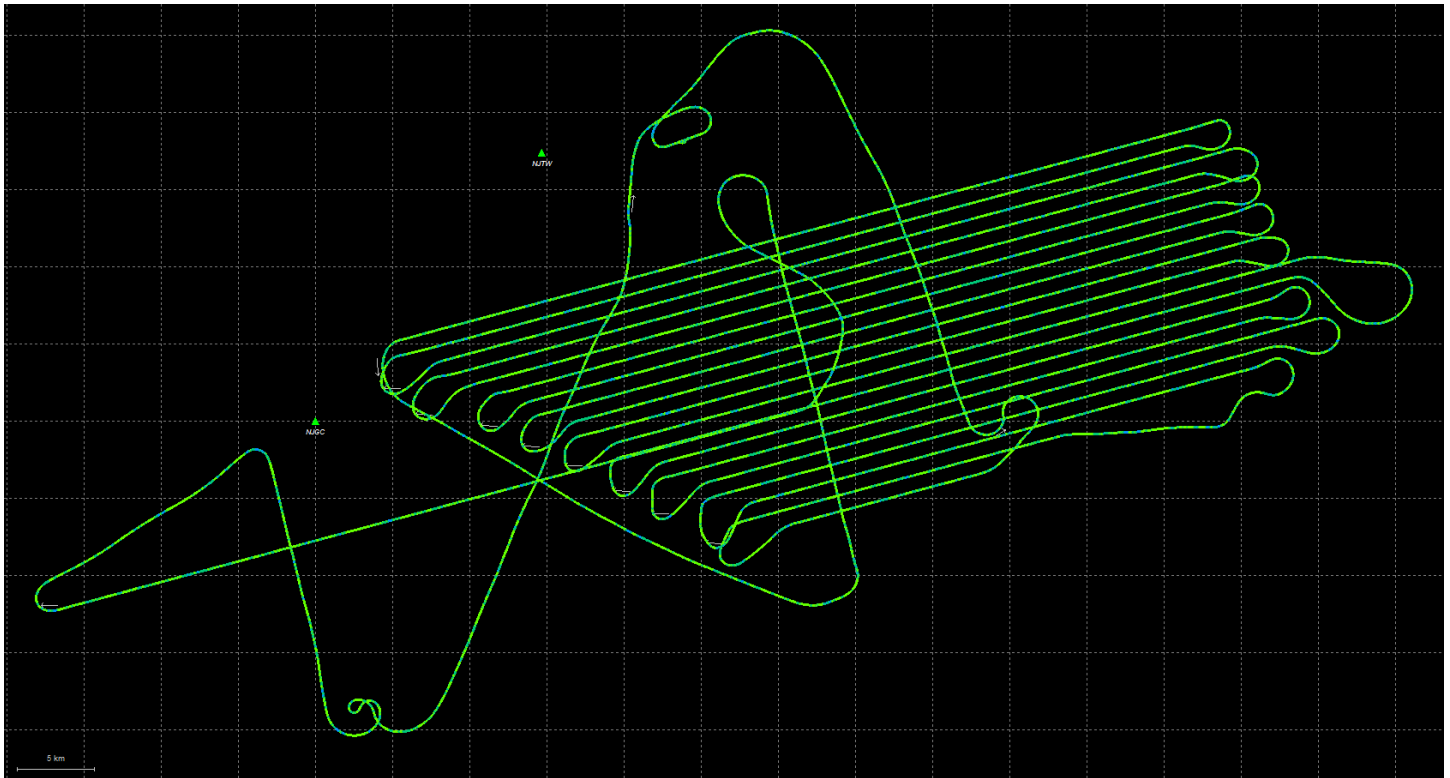

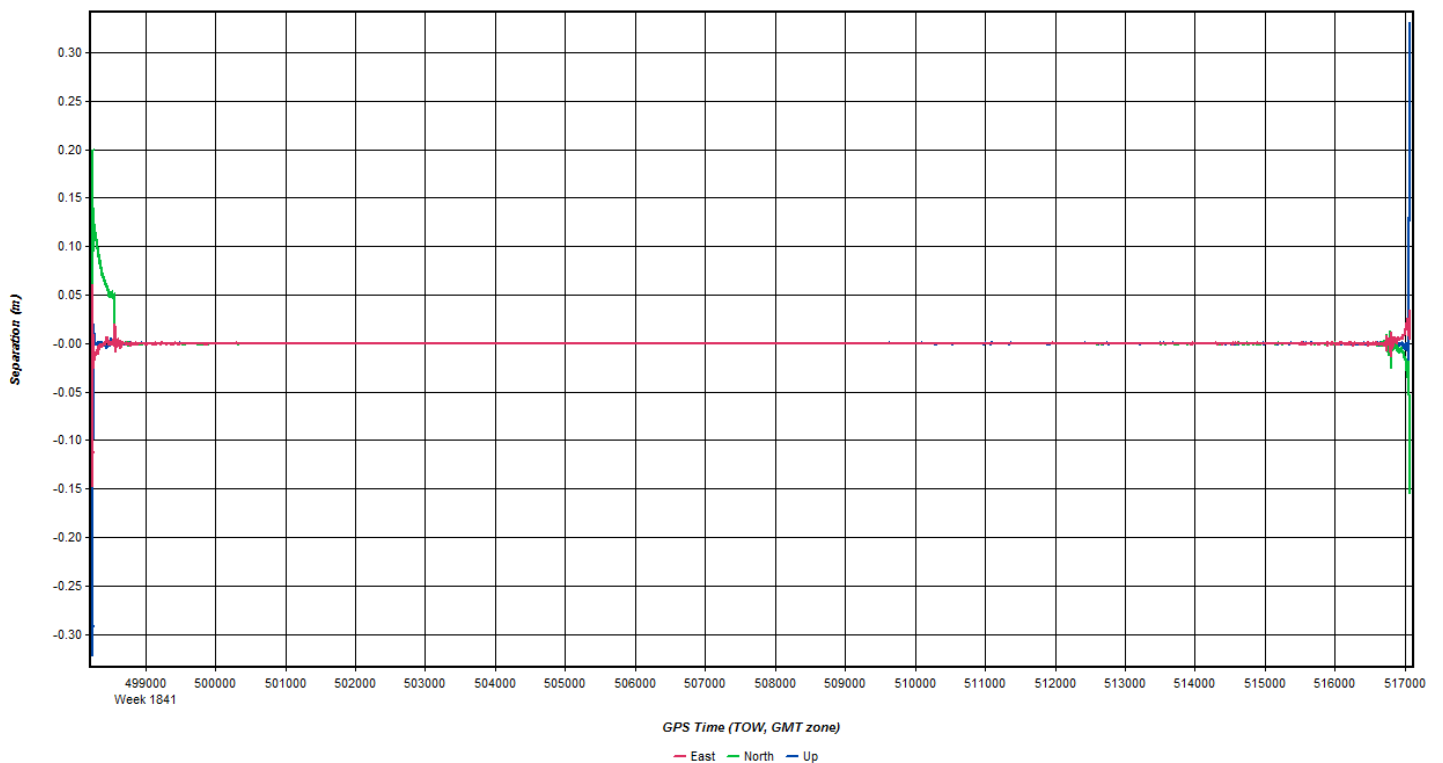
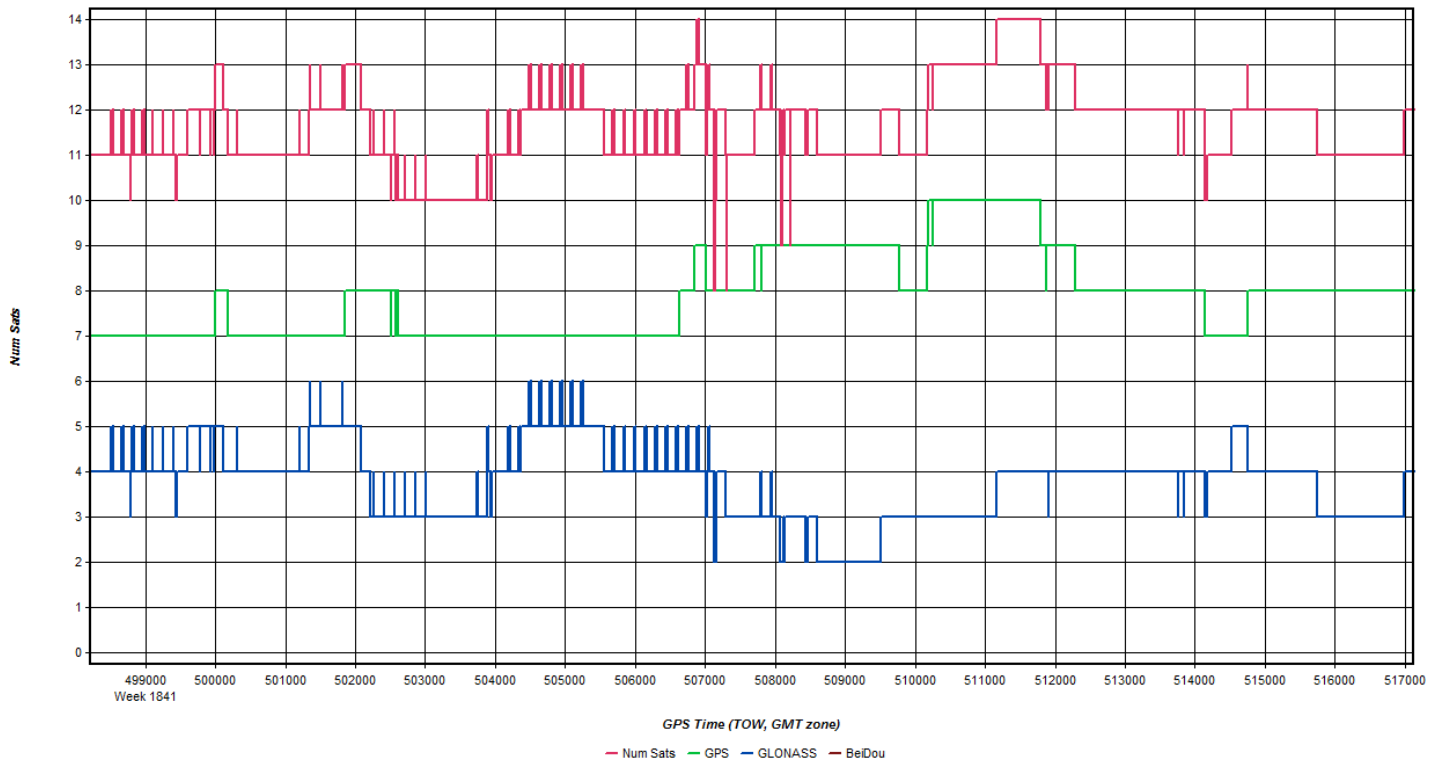

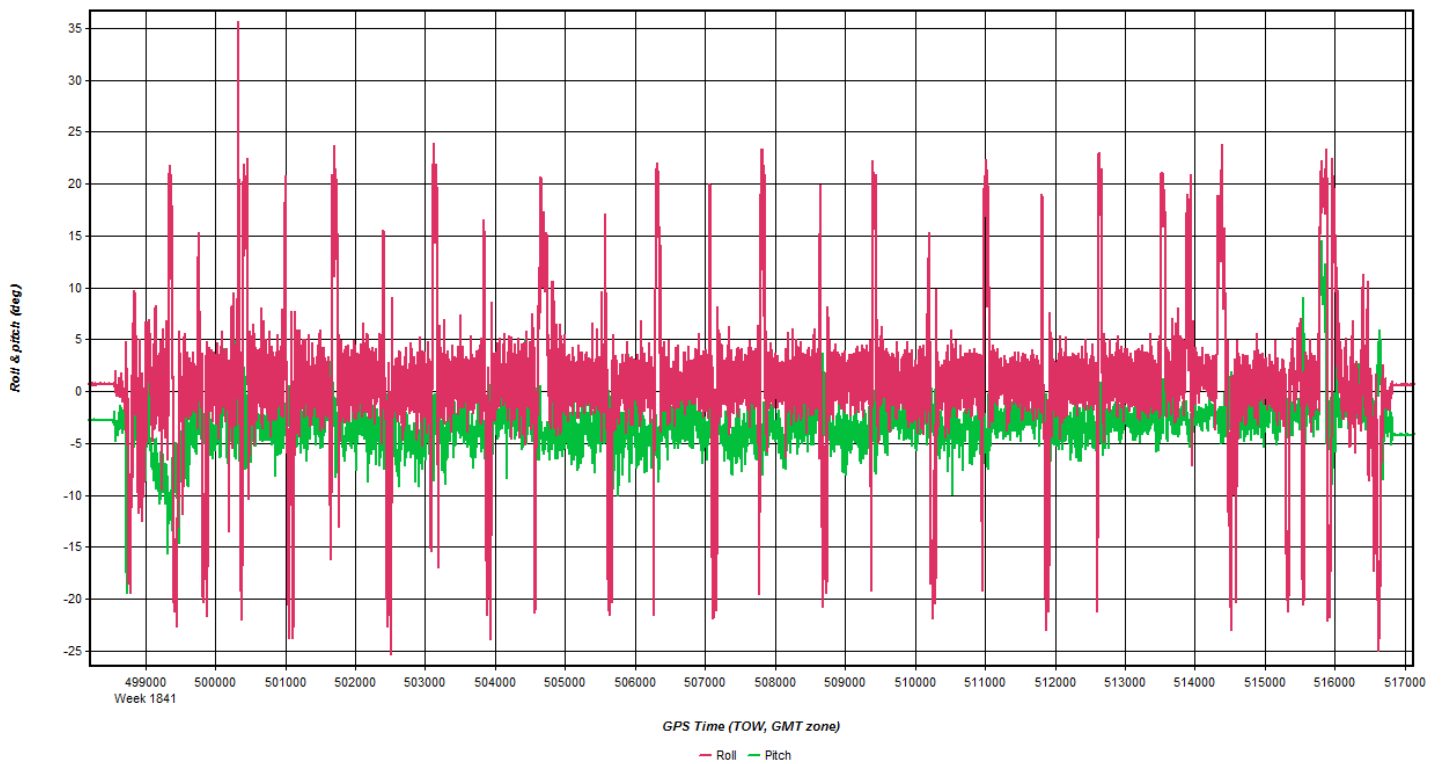
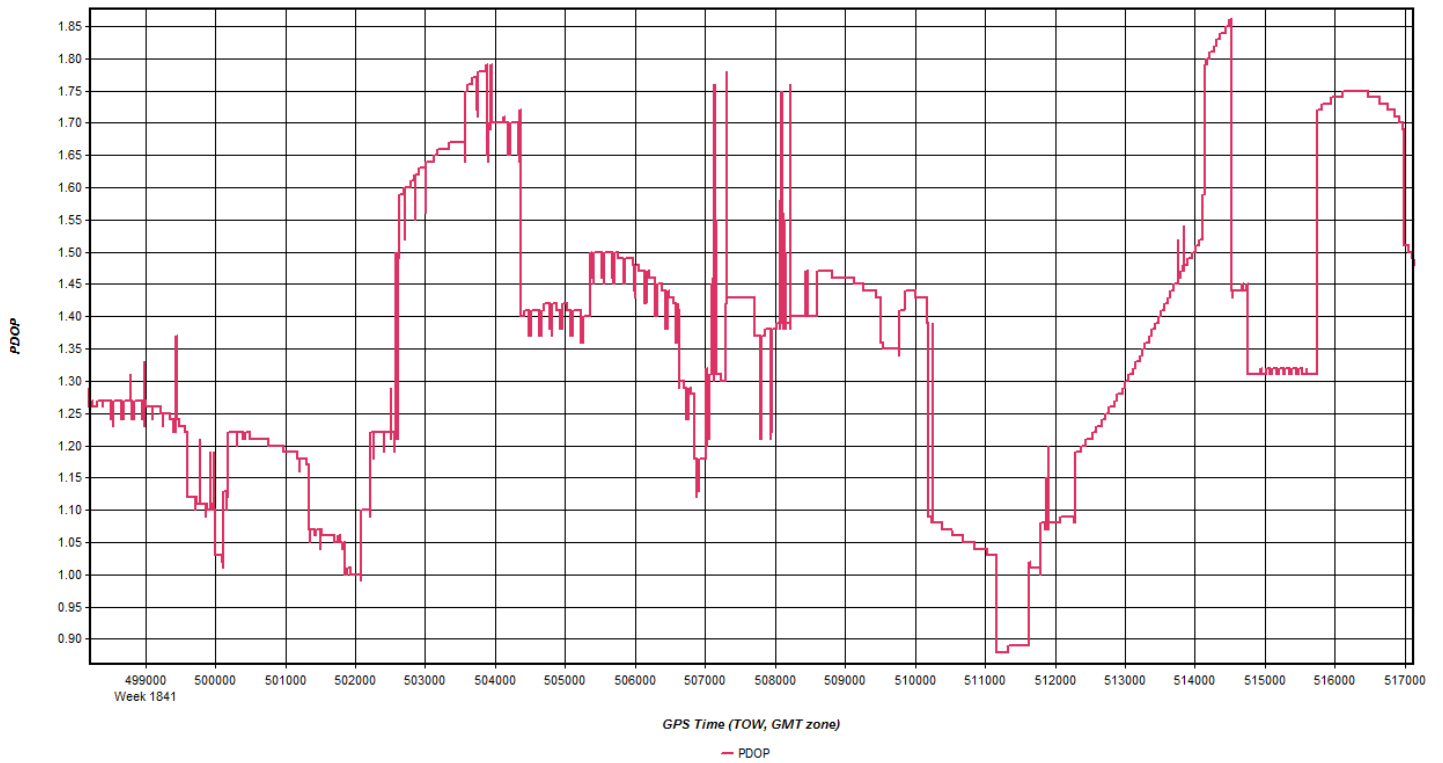

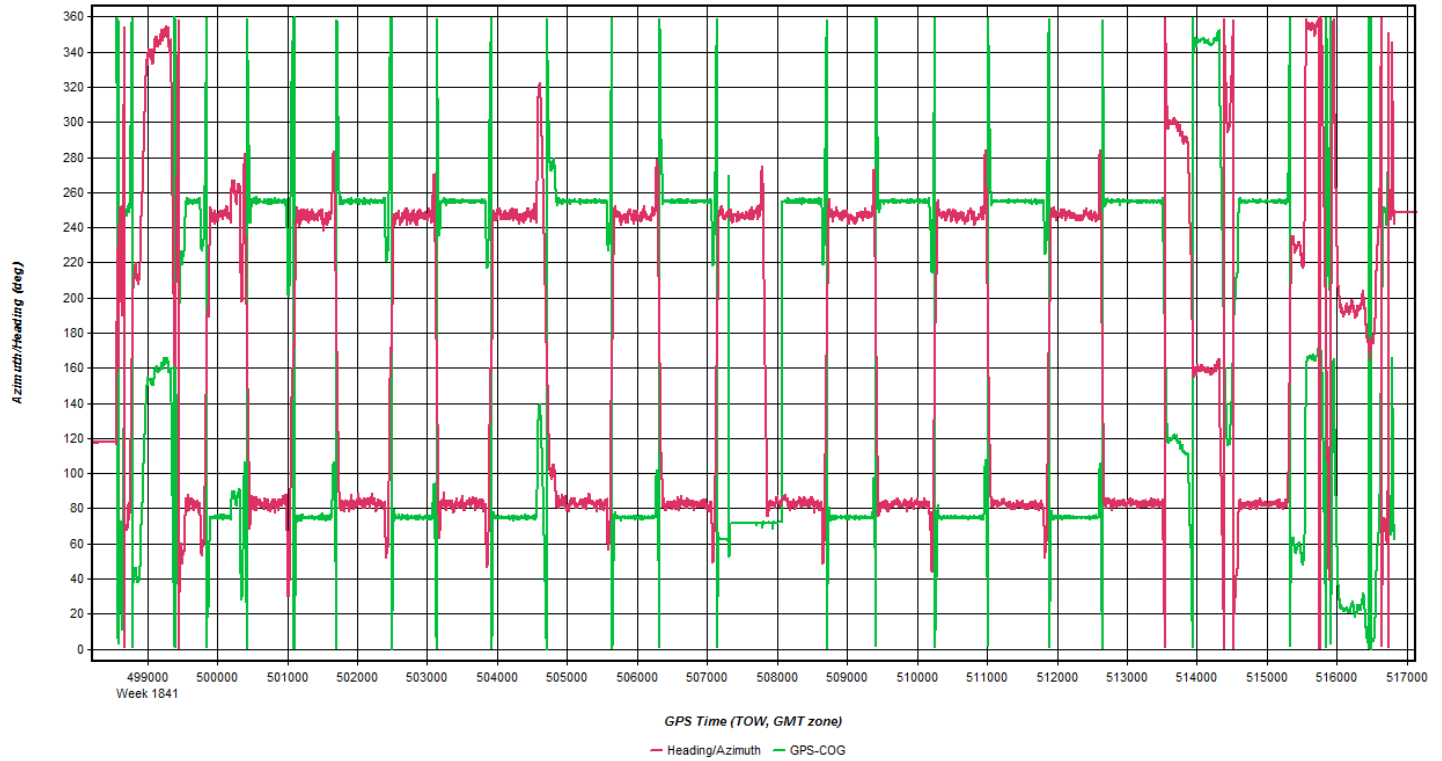

**Coordinate/Antenna Settings**

Master Remote

Base Station  
 1: NJGC Name: NJGC  Disabled  
 File: G:\Proc\26236\_DVRPC\ZAMG\20150424\_181835\njgc1140.gpt

Coordinates  
 Latitude: North 39 46 52.79148   
 Longitude: West 75 07 11.25002   
 Ellipsoidal height: -3.994 m   
 Datum: NAD83(2011)

Antenna Height  
 From station file: LEIAR10, NONE   
 Antenna profile: LEIAR10   
 Measured height: 0.000 m  
 ARP to L1 offset: 0.089 m  
 Applied height: 0.089 m  
 Measured to:  
 ARP  
 L1 Phase Centre

Coordinate/Antenna Settings

Master Remote

Base Station  
2: NJTW Name: NJTW  Disabled  
File: G:\Proc\26236\_DVRPC\ZAMG\20150424\_181835\vrijtw1140.gpb

Coordinates  
Latitude: North 39 56 11.04331   
Longitude: West 74 56 58.71204   
Ellipsoidal height: -20.002 m   
Datum: NAD83(2011)

Antenna Height  
From station file: TRM41249.00, NONE   
Antenna profile: TRM41249.00   
Measured height: 0.046 m  
ARP to L1 offset: 0.056 m  
Applied height: 0.102 m  
Measured to:  
 ARP  
 L1 Phase Centre

OK Cancel



# Flight Log

4/24 &amp; 4/25

**DVRPC KWAY South Jersey SN7234 QL2**

QSI Project #	26236
Sensor Name	ALS70 7234
Flight Plan Style	Fixed MSL
Project Point Density (pts/m <sup>2</sup> )	2

Flight Plan Settings	
DEM Used for Planning	SRTM 30m
Target Speed (kts)	150
Max Bank Angle in Turns (°)	30
Minimum Line Overlap (%)	30
Pulses in Air Mode	MP/A
Scan Pattern	Triangle
Fixed Gain	255
Roll Comp. (ON/OFF)	N/A
Allowed vertical deviation (m)	
	<b>Min.</b>
AGL (m) varies by line	2000
MSL (ft) varies by line	6348
FOV Range (°)	40.0
Scan Rate (Hz)	53.4
Swath Width (m)	1456
Laser Power (%)	100
Pulse Rate (Hz)	273000
	<b>Max</b>

\*Shading = Auto-calculated

**Other Acquisition Notes:**

Lines should be flown at the altitude (in FEET above sea level) indicated on the flight sheet. Give this number to the pilot for each line and have him use the altimeter on his instrument panel. The plane's altimeter is adjusted for pressure. Please note that each line is at a different altitude.

Project Flight Time Estimate	
Total Line Length (nmi)	1199
Total Line Time (hrs, no buffer)	8.0
Total Number of Lines	48
Turn Time (min)	4
Total Turn Time (hrs, no buffer)	3.2
Buffer (%)	10
MOB Dist. Round Trip (nmi)	60
Number of MOBs	3
Total Acquisition Time (hrs)	13.5

Mission Flight Time Estimate	
Start Line Name	1001
Stop Line Name	1042
Turn Time (min)	4
Buffer (%)	10
Acquisition Time (hrs)	#N/A

Line Name	Total Line Length [nm]	Flying Altitude [ft MSL]	Time Stamp	Refly Time Stamp	Sats./P DOP	Notes (Direction, Atmospheric Conditions, Speed, PR, Errors, etc.)
6001	24	6385				
6002	24	6385				
6003	24	6424	152710		18/1.0	
6004	25	6417	154016		17/1.0	
6005	25	6404	155254		16/1.2	
6006	25	6404	160543		16/1.2	pilot display changed color/time
6007	26	6371	161830		16/1.3	
6008	26	6417	163212		16/1.3	
6009	26	6424	164519		16/1.3	
6010	27	6424	165932		16/1.3	
6011	27	6348				
6012	27	6423				
6013	28	6352				
6014	28	6352				
6015	28	6439				
6016	29	6447				
6017	29	6436				
6018	29	6420				
6019	30	6426				
6020	30	6437				
6021	30	6417				
6022	30	6437				
6023	30	6443				
6024	30	6440				
6025	29	6439				
6026	29	6447				
6027	28	6450				
6028	28	6457	222500		17/1.1	
6029	27	6467	222159		17/1.2	
6030	27	6489	215758		17/1.3	
6031	26	6493	214500		17/1.3	
6032	25	6499	213111		18/1.1	

4/25/2015

pilot display changed color/time

171351

222544

4/24

time stamp sig PPR

17/1.1

225728

16/1.2

231240

time

cross keys

7018

4/24

6033	25	6498	211853	20/1.0
6034	24	6526	210451	20/1.0
6035	24	6512	205246	18/1.1
6036	23	6506	203942	18/1.0
6037	23	6515	202781	17/1.1
6038	22	6508	201449	17/1.1
6039	21	6509	195906	17/1.3
6040	21	6503	194631	16/1.0
6041	20	6492	193524	18/1.1
6042	20	6486	192307	20/1.0
6043	19	6489	191206	19/1.0
6044	15	6489	190223	18/1.1
6045	10	6486	185153	10/1.3
6046	5	6482	184605	10/1.5
6047	24	6470		
6048	26	6417		

# Base Station Log

### GPS OBSERVATION LOG

Station ID KVA Y Airport  
 Project Number 262310  
 Project Name DVRPC  
 Rcvr. Type Novate / DL V3 L1L2  
 Rcvr. S/N 7-0141418  
 Antenna Type Novatel 1.03 HW Rev  
 Antenna S/N 01017577

Date 4/25 +  
4/24/2015  
 Julian Date 114/115  
 Start Time 14:04:00:PM / 10:35  
 Stop Time 14:25:00:PM / 13:35  
 Rcvr. File Name 24th  
 Observer Charlie Onsea  
25th

New or Existing

Mon.  New

Existing

Photo Taken:

Yes  No

Monument Type:

Spike  PK Nail

AM Washer

Other

Height Readings:

(Top of Monument to Bottom of Ground Plane)

Start	$\left. \begin{matrix} 1.5 & \text{M.} & 1.8\text{m} \\ 1.5 & \text{M.} & 1.8\text{m} \\ 1.5 & \text{M.} & 1.8\text{m} \end{matrix} \right\} 25^{\text{th}}$	Ft.
Stop <u>24th</u>		Ft.
Mean		Ft.

Control point set by Mike Aust on previous mission, no name given

Monument Sketch and Notes:

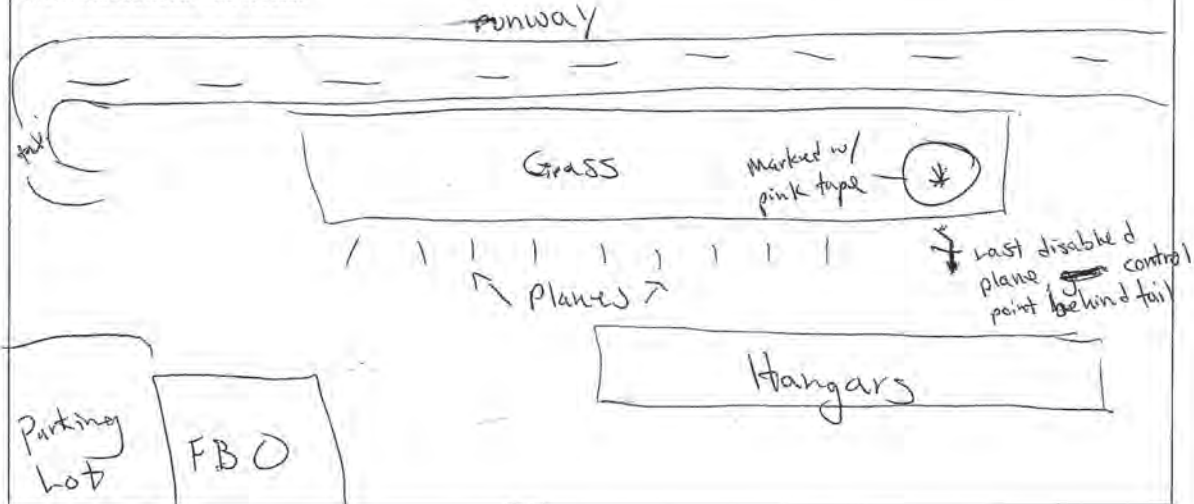

**Apr 25, 2015-A  
(N269JE, SN7234)**

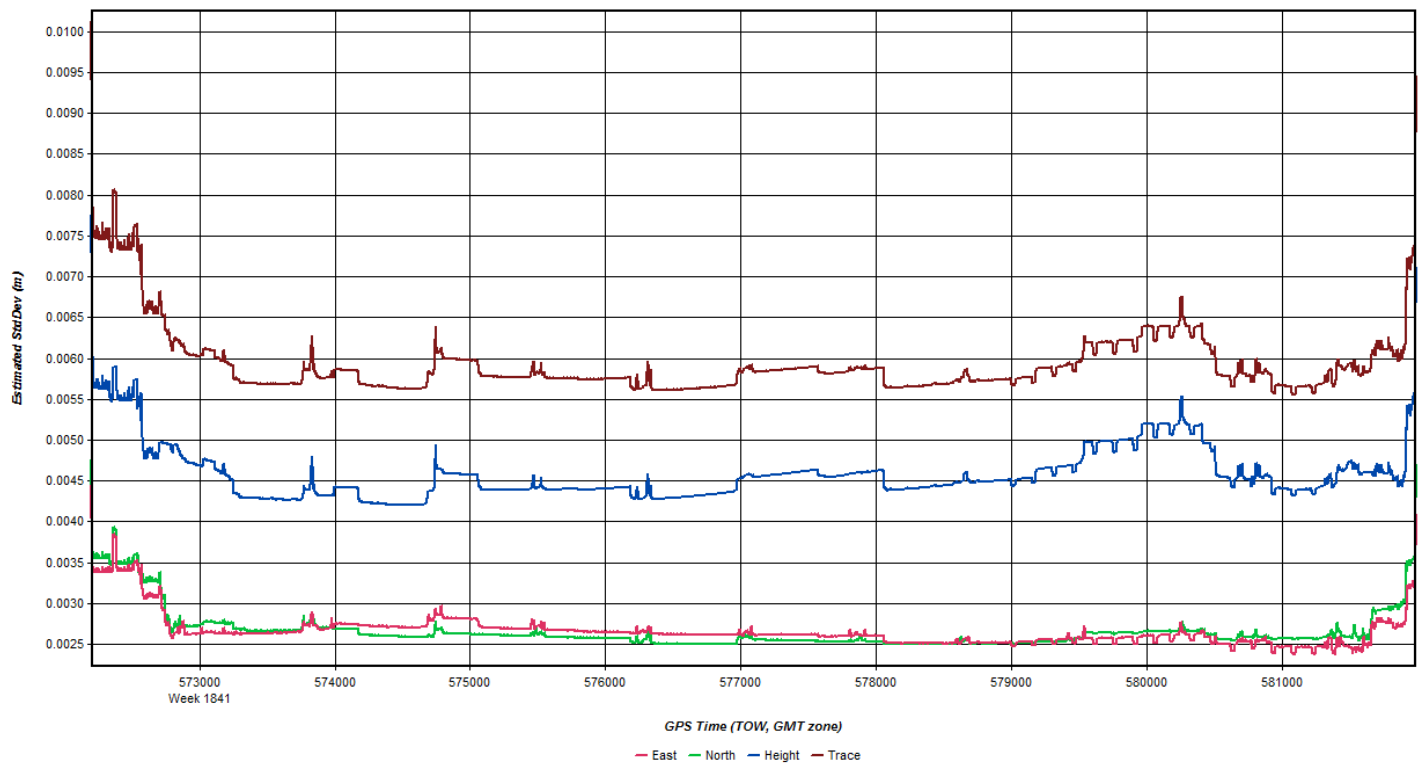
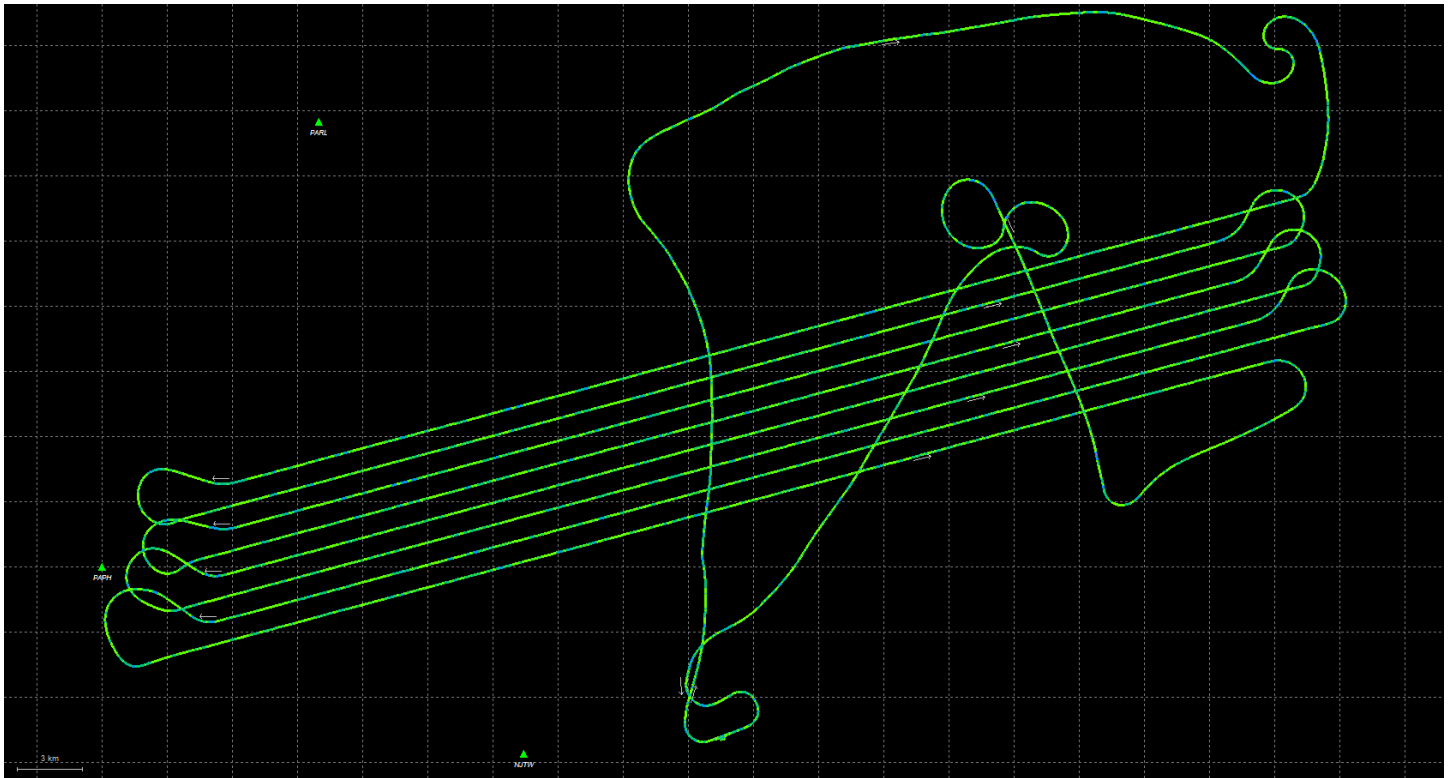



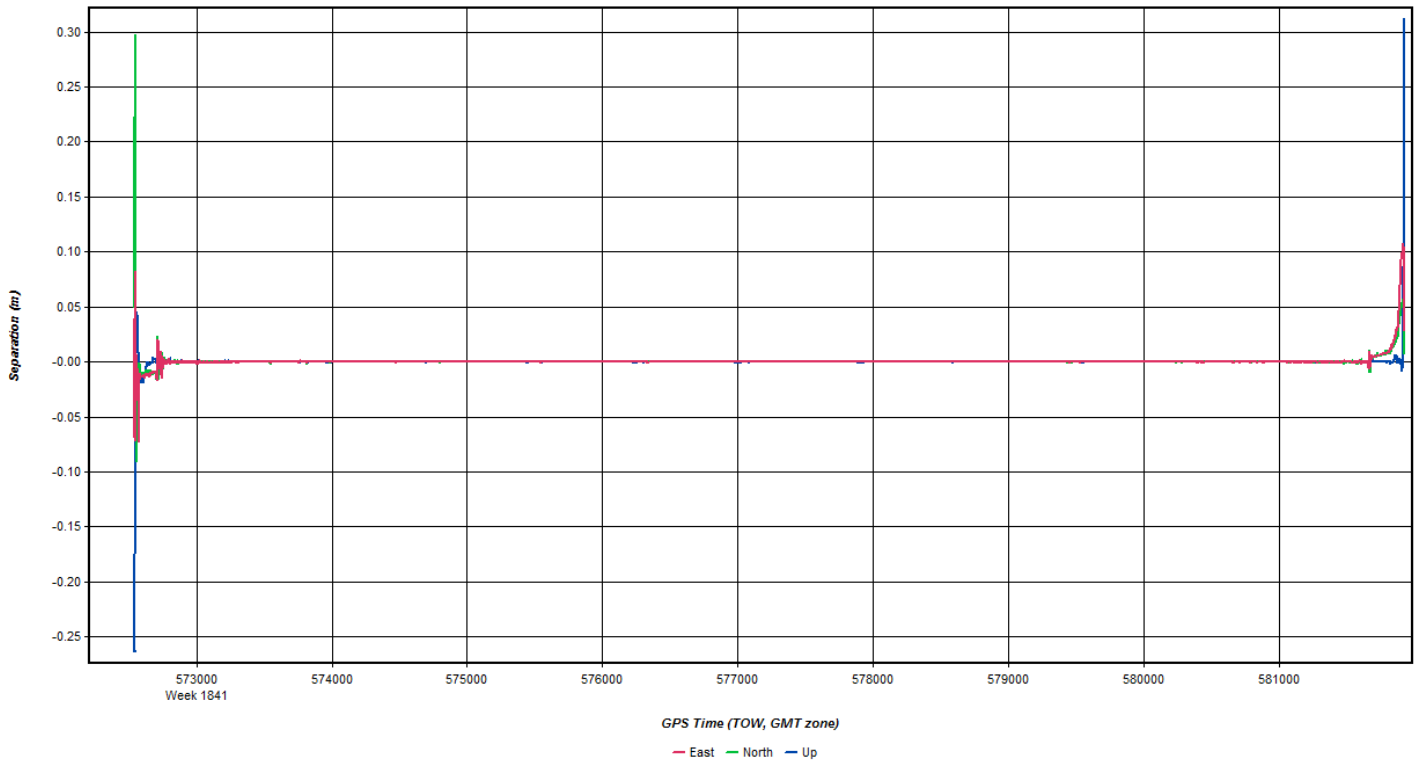
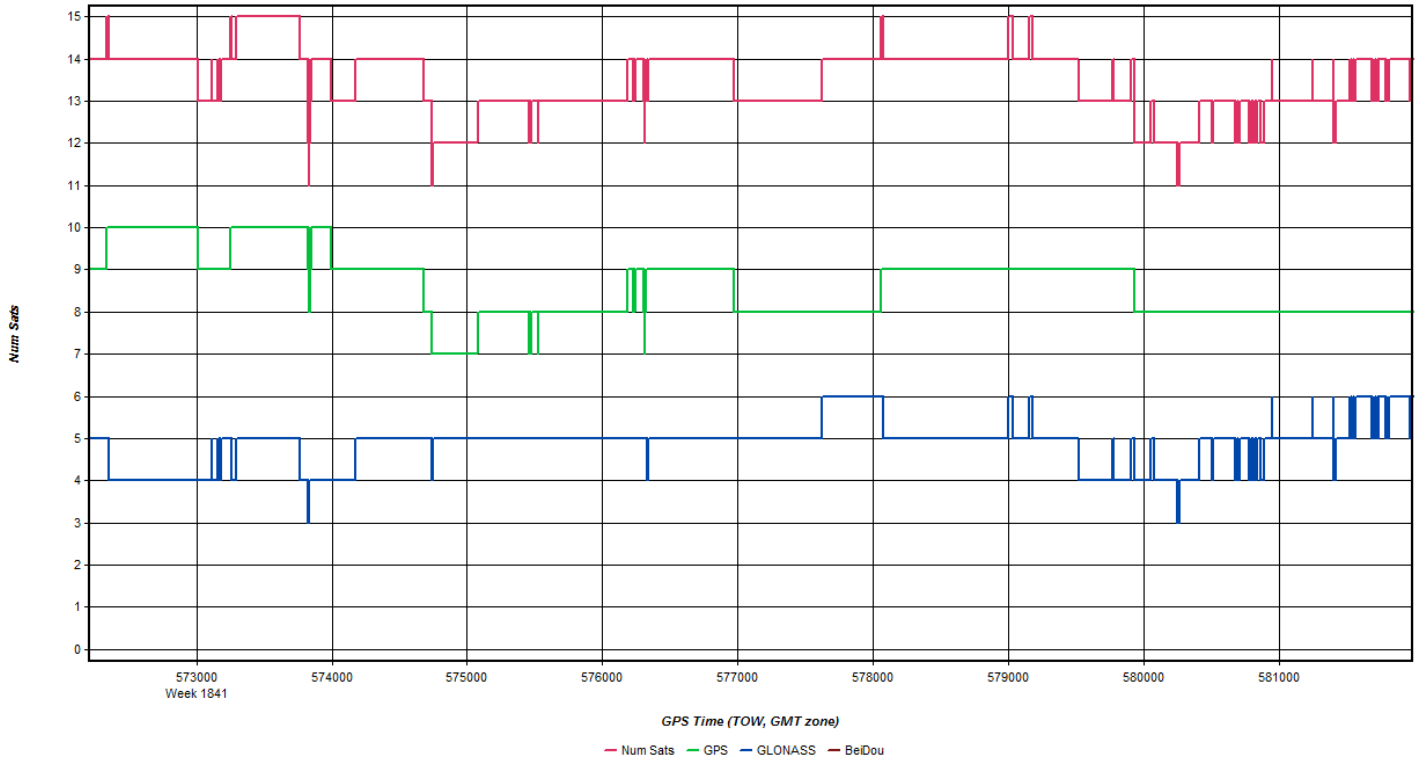

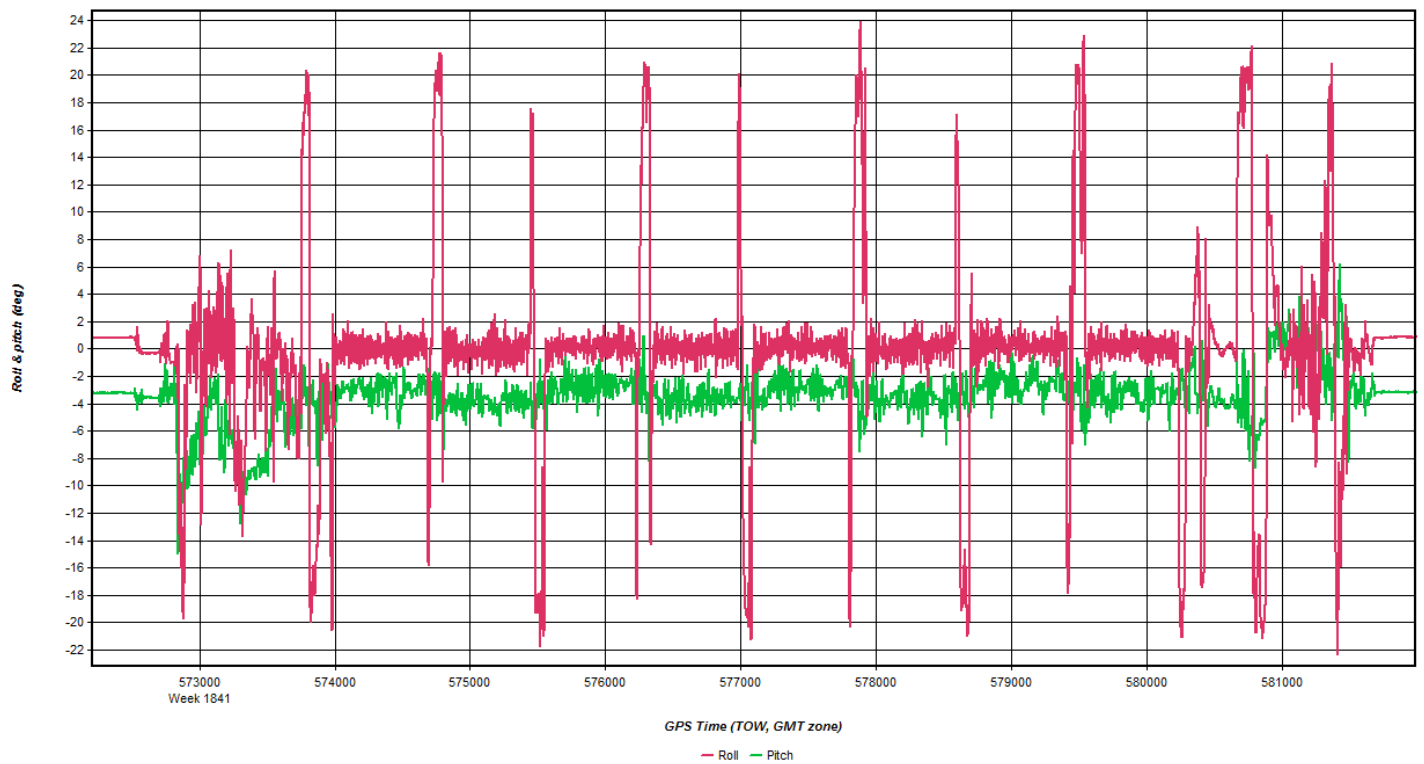
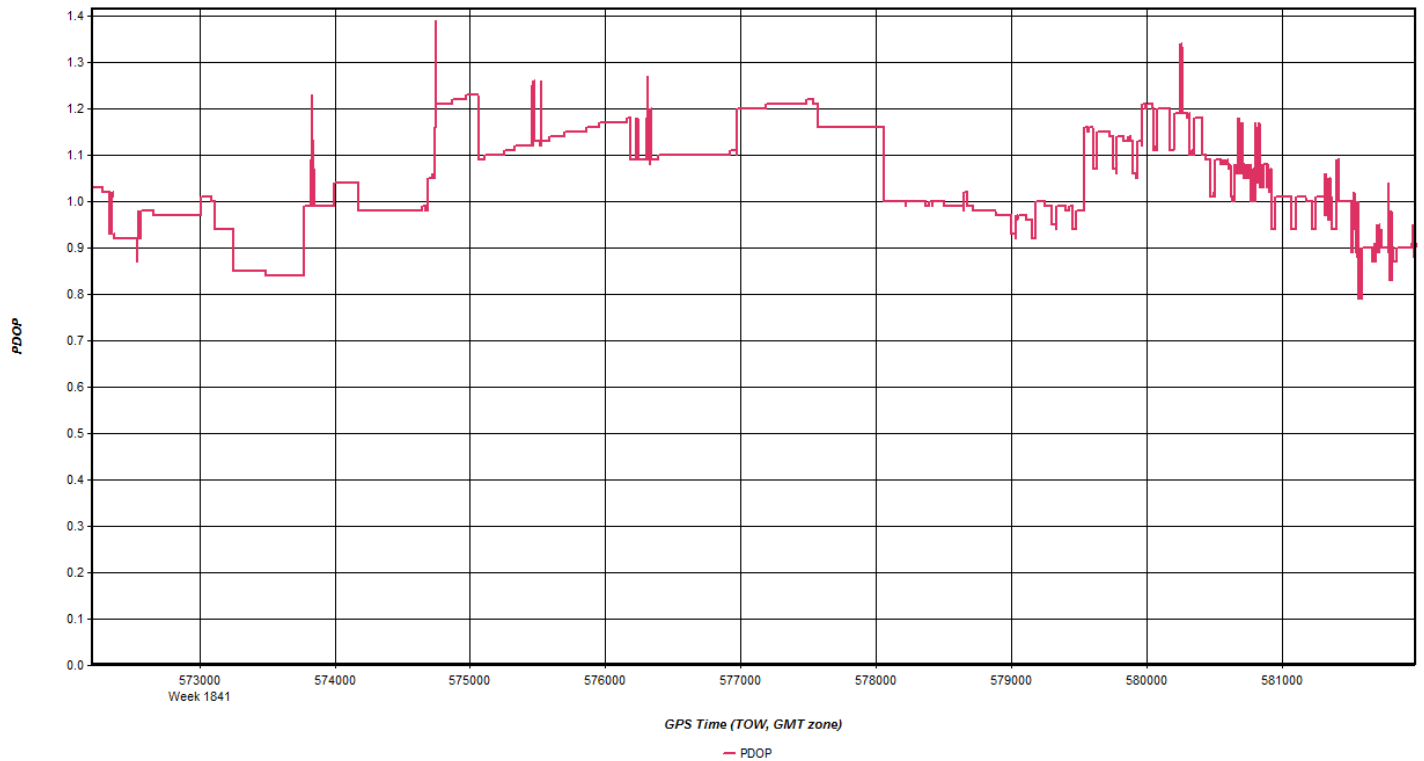

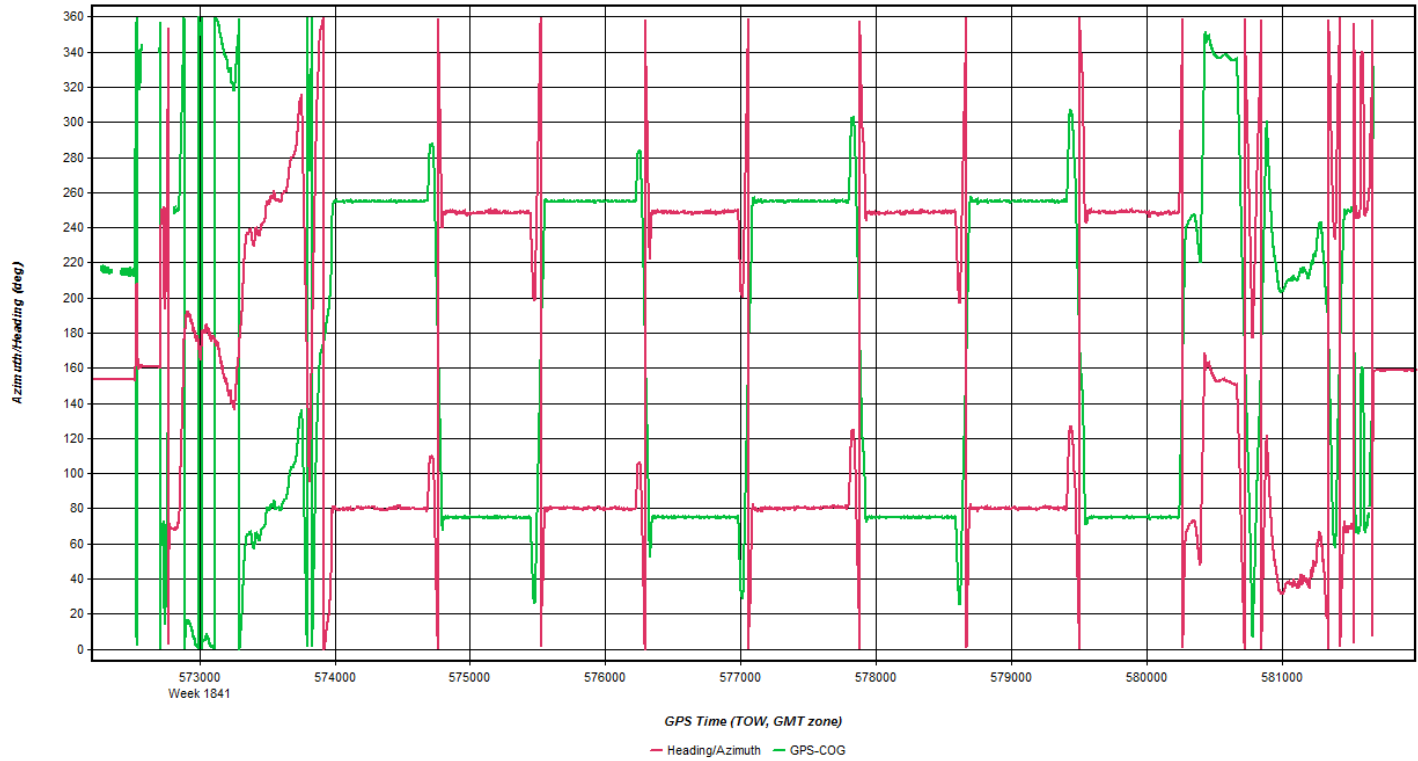

**Coordinate/Antenna Settings**

Master Remote

Base Station  
 2: NJTW Name: NJTW  Disabled  
 File: G:\Proc\26236\_DVRPC\ZAMG\20150425\_145220\vnjtw1150.gpb

Coordinates  
 Latitude: North 39 56 11.04331   
 Longitude: West 74 56 58.71204   
 Ellipsoidal height: -20.002 m   
 Datum: NAD83(2011)

Antenna Height  
 From station file: TRM41249.00, NONE   
 Antenna profile: TRM41249.00   
 Measured height: 0.046 m  
 ARP to L1 offset: 0.056 m  
 Applied height: 0.102 m  
 Measured to:  
 ARP  
 L1 Phase Centre

Coordinate/Antenna Settings

Master Remote

Base Station  
 1: PAPH Name: PAPH  Disabled  
 File: G:\Proc\26236\_DVRPC\ZAMG\20150425\_145220\paph1150.gp

Coordinates  
 Latitude: North 40 00 47.34854 Compute from PPP  
 Longitude: West 75 10 34.78766 Enter Grid Values  
 Ellipsoidal height: 27.809 m Enter MSL Height  
 Datum: NAD83(2011) Datum Options  
 Select From Favorites Add To Favorites Use Average Position

Antenna Height  
 From station file: LEIAX1202GG, NONE View STA File  
 Antenna profile: LEIAX1202GG Info  
 Measured height: 0.000 m Measured to  
 ARP to L1 offset: 0.063 m  ARP  
 Applied height: 0.063 m  L1 Phase Centre  
 Compute From Slant

OK Cancel

Coordinate/Antenna Settings

Master Remote

Base Station  
 3: PARL Name: PARL  Disabled  
 File: G:\Proc\26236\_DVRPC\ZAMG\20150425\_145220\parl1150.gpb

Coordinates  
 Latitude: North 40 11 46.22401 Compute from PPP  
 Longitude: West 75 03 35.66418 Enter Grid Values  
 Ellipsoidal height: 76.548 m Enter MSL Height  
 Datum: NAD83(2011) Datum Options  
 Select From Favorites Add To Favorites Use Average Position

Antenna Height  
 From station file: TRM57971.00, NONE View STA File  
 Antenna profile: TRM57971.00 Info  
 Measured height: 0.000 m Measured to  
 ARP to L1 offset: 0.067 m  ARP  
 Applied height: 0.067 m  L1 Phase Centre  
 Compute From Slant

OK Cancel

# Flight Log

4/24 & 4/25

## DVRPC KWAY South Jersey SN7234 QL2



QSI Project #	26236
Sensor Name	ALS70 7234
Flight Plan Style	Fixed MSL
Project Point Density (pts/m <sup>2</sup> )	2

Flight Plan Settings	
DEM Used for Planning	SRTM 30m
Target Speed (kts)	150
Max Bank Angle in Turns (°)	30
Minimum Line Overlap (%)	30
Pulses in Air Mode	MP/A
Scan Pattern	Triangle
Fixed Gain	255
Roll Comp. (ON/OFF)	N/A
Allowed vertical deviation (m)	
	<b>Min.</b>
AGL (m) varies by line	2000
MSL (ft) varies by line	6348
FOV Range (°)	40.0
Scan Rate (Hz)	53.4
Swath Width (m)	1456
Laser Power (%)	100
Pulse Rate (Hz)	273000
	<b>Max</b>

\*Shading = Auto-calculated

### Other Acquisition Notes:

Lines should be flown at the altitude (in FEET above sea level) indicated on the flight sheet. Give this number to the pilot for each line and have him use the altimeter on his instrument panel. The plane's altimeter is adjusted for pressure. Please note that each line is at a different altitude.

Project Flight Time Estimate	
Total Line Length (nmi)	1199
Total Line Time (hrs, no buffer)	8.0
Total Number of Lines	48
Turn Time (min)	4
Total Turn Time (hrs, no buffer)	3.2
Buffer (%)	10
MOB Dist. Round Trip (nmi)	60
Number of MOBs	3
Total Acquisition Time (hrs)	13.5

Mission Flight Time Estimate	
Start Line Name	1001
Stop Line Name	1042
Turn Time (min)	4
Buffer (%)	10
Acquisition Time (hrs)	#N/A

Line Name	Total Line Length [nm]	Flying Altitude [ft MSL]	Time Stamp	Refly Time Stamp	Sats./P DOP	Notes (Direction, Atmospheric Conditions, Speed, PR, Errors, etc.)
6001	24	6385				
6002	24	6385				
6003	24	6424	152710		18/1.0	
6004	25	6417	154016		17/1.0	
6005	25	6404	155254		16/1.2	
6006	25	6404	160543		16/1.2	pilot display changed color/trim
6007	26	6371	161830		16/1.3	
6008	26	6417	163212		16/1.3	
6009	26	6424	164519		16/1.3	
6010	27	6424	165932		16/1.3	
6011	27	6348				
6012	27	6423				
6013	28	6352				
6014	28	6352				
6015	28	6439				
6016	29	6447				
6017	29	6436				
6018	29	6420				
6019	30	6426				
6020	30	6437				
6021	30	6417				
6022	30	6437				
6023	30	6443				
6024	30	6440				
6025	29	6439				
6026	29	6447				
6027	28	6450				
6028	28	6457	222500		17/1.1	
6029	27	6467	222159		17/1.2	
6030	27	6489	215758		17/1.3	
6031	26	6493	214500		17/1.3	
6032	25	6499	213111		18/1.1	

4/25/2015

pilot display changed color/trim

171351

222544

4/24

sig PRAP

time stamp

17/1.1

225728

line 7018

CROSS keys

17/1.1

231240

↓

16/1.2

4/24

6033	25	6498	211853	20/1.0
6034	24	6526	210451	20/1.0
6035	24	6512	205246	18/1.1
6036	23	6506	203942	18/1.0
6037	23	6515	202751	17/1.1
6038	22	6508	201449	17/1.1
6039	21	6509	195906	17/1.3
6040	21	6503	194631	16/1.0
6041	20	6492	193524	18/1.1
6042	20	6486	192307	20/1.0
6043	19	6489	191200	18/1.0
6044	15	6489	190223	18/1.1
6045	10	6486	185153	10/1.3
6046	5	6482	184005	10/1.5
6047	24	6470		
6048	26	6417		



# Base Station Log

### GPS OBSERVATION LOG

Station ID KVA Y Airport  
 Project Number 262310  
 Project Name DVRPC  
 Rcvr. Type Novate / DL V3 L1L2  
 Rcvr. S/N 7-0141418  
 Antenna Type Novatel 1.03 HW Rev  
 Antenna S/N 01017577

Date 4/25 +  
4/24/2015  
 Julian Date 114/115  
 Start Time 14:04:00:PM / 10:35  
 Stop Time 14:25:00:PM / 13:35  
 Rcvr. File Name 24th  
 Observer Charlie Onsea  
25th

New or Existing

Mon.  New

Existing

Photo Taken:

Yes  No

Monument Type:

Spike  PK Nail

AM Washer

Other

Height Readings:

(Top of Monument to Bottom of Ground Plane)

Start	$\left. \begin{array}{l} 1.5 \text{ M. } 1.8 \text{ m} \\ 1.5 \text{ M. } 1.8 \text{ m} \\ 1.5 \text{ M. } 1.8 \text{ m} \end{array} \right\} 25^{\text{th}}$	Ft.
Stop <u>24th</u>		Ft.
Mean		Ft.

Control point set by Mike Aust on previous mission, no name given

Monument Sketch and Notes:

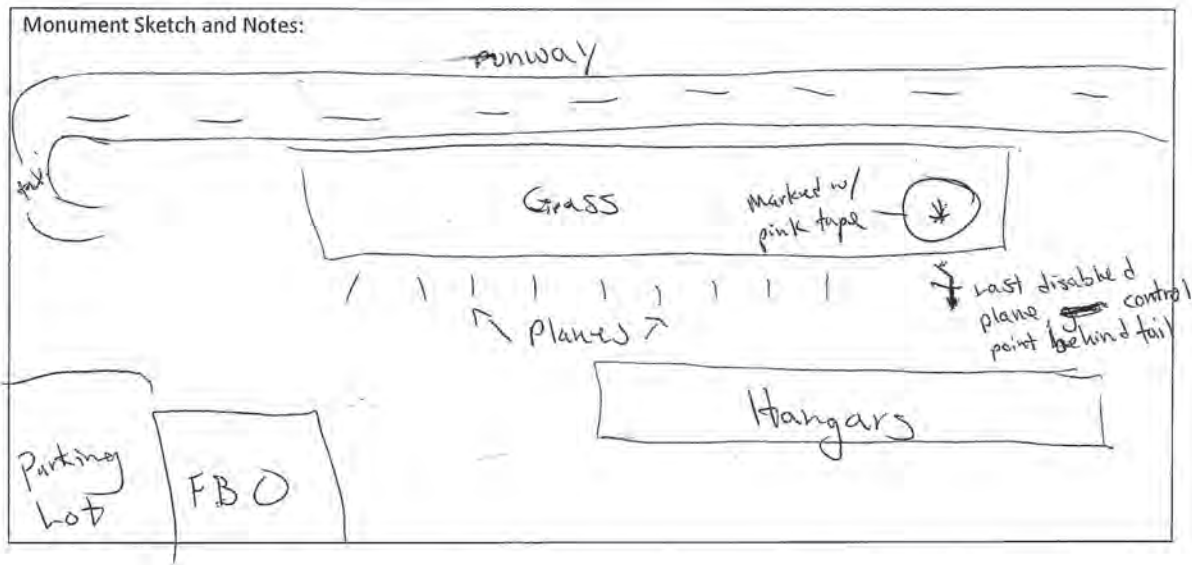

# May 23, 2015-A (N22GE, SN8239)

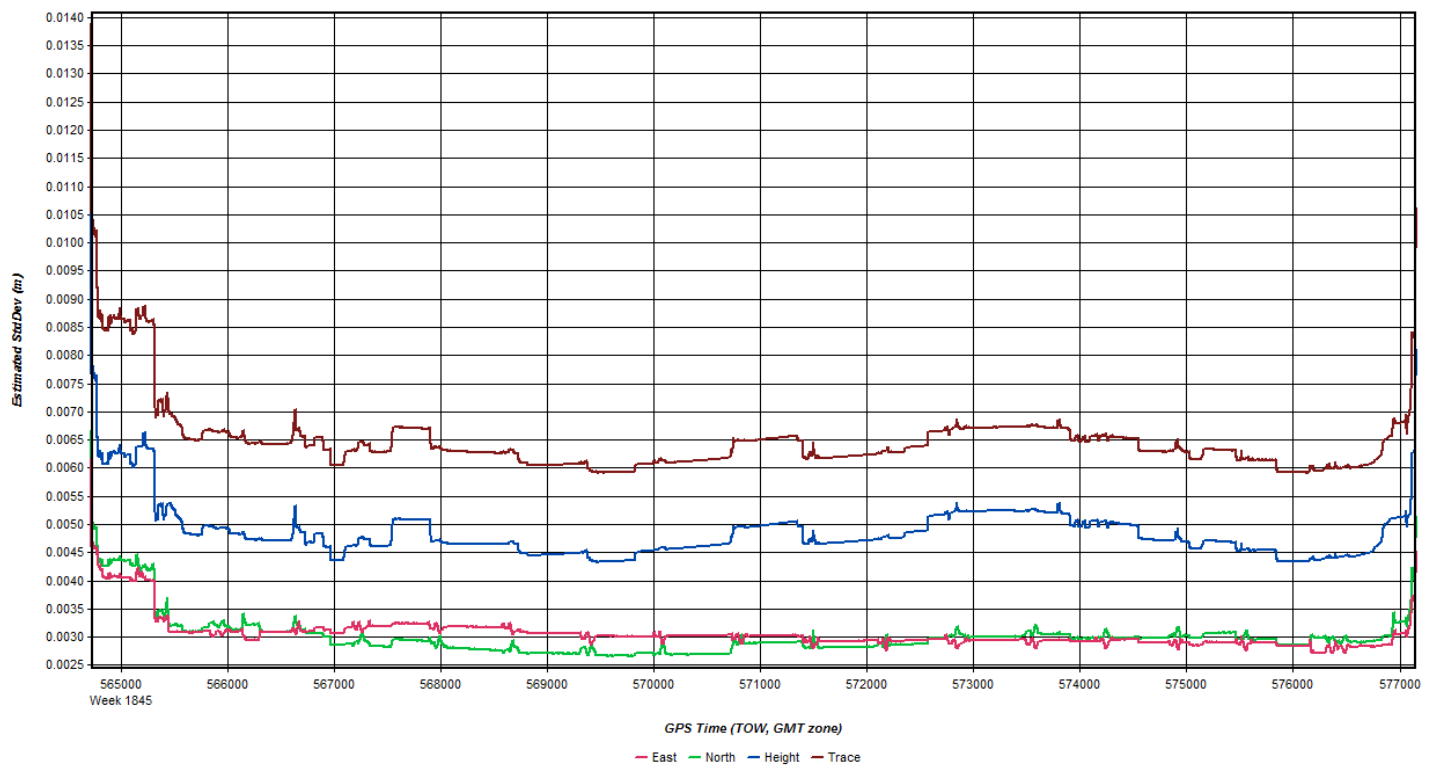
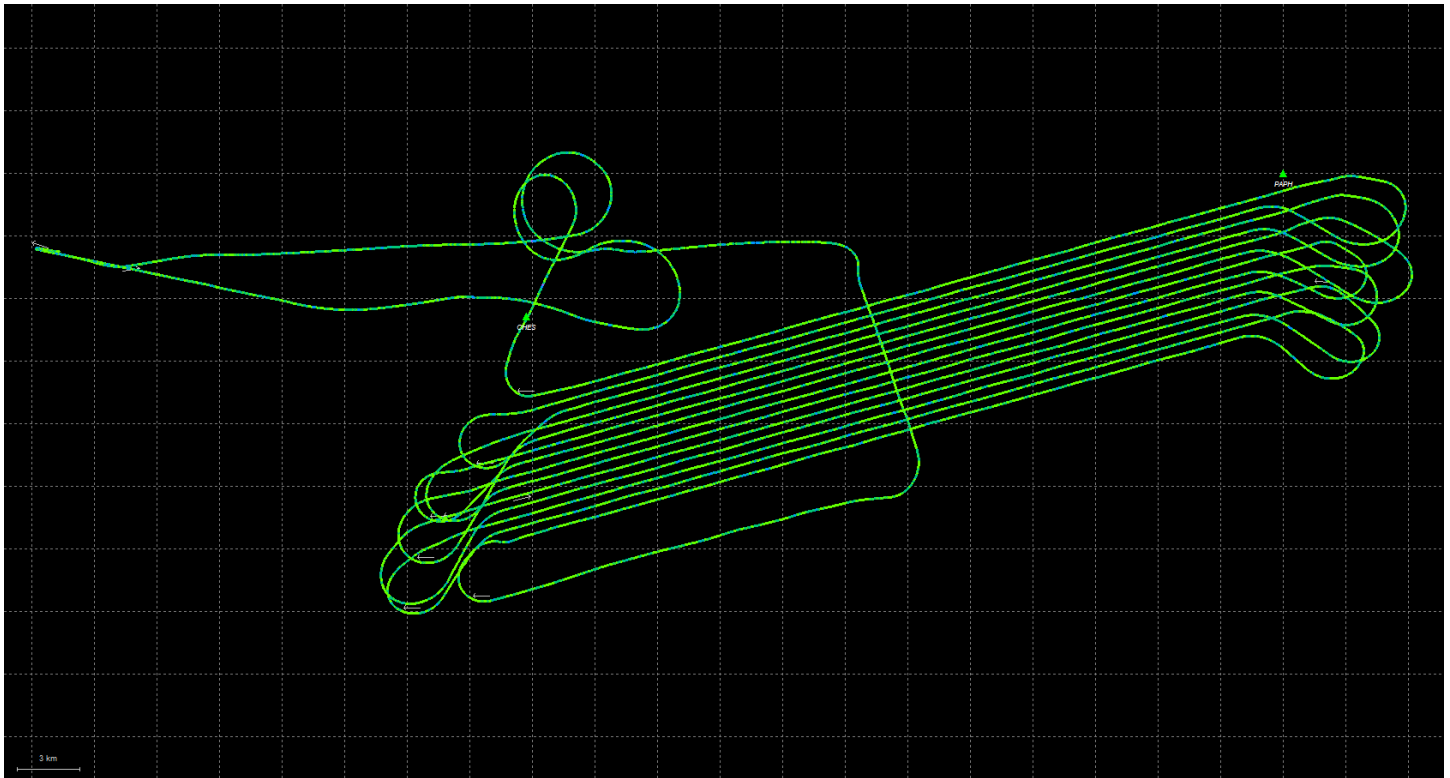

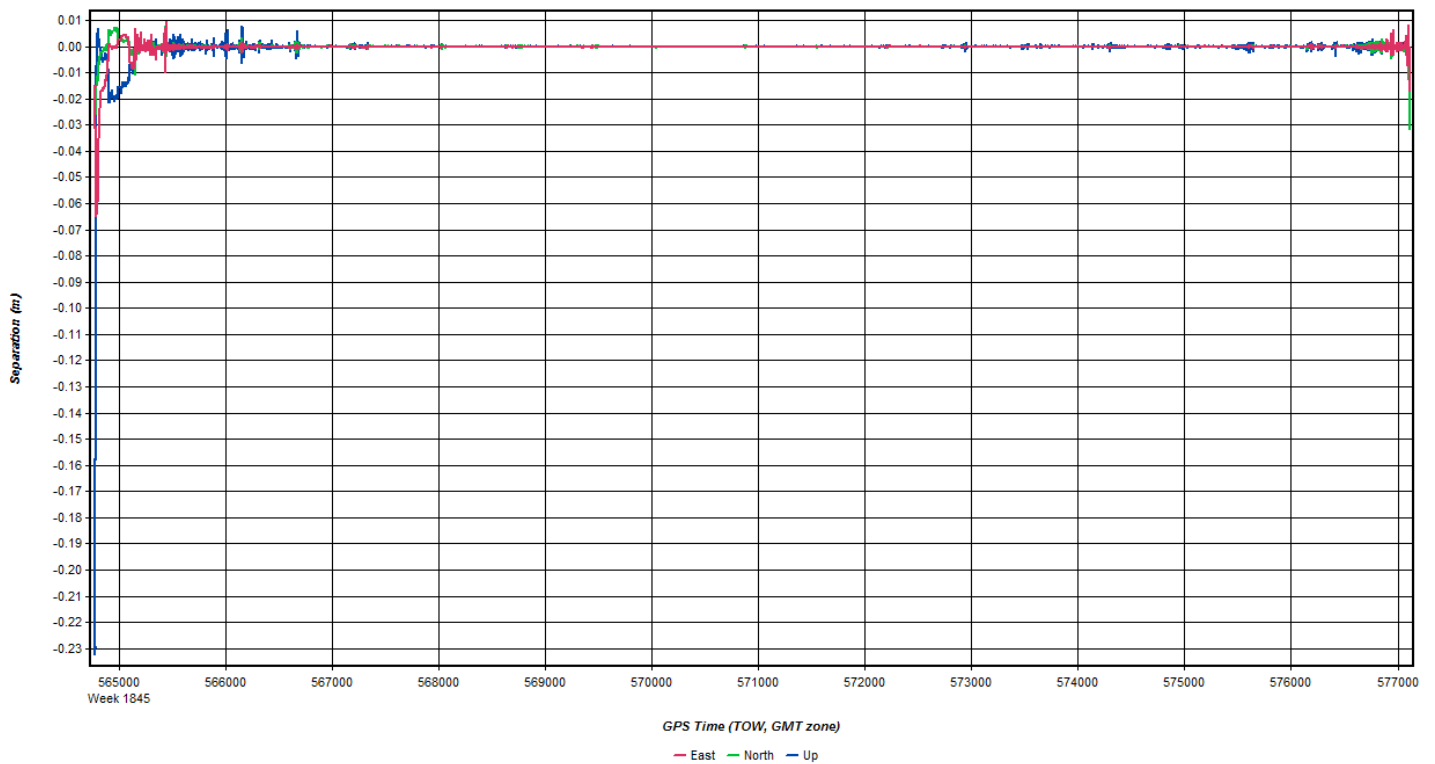
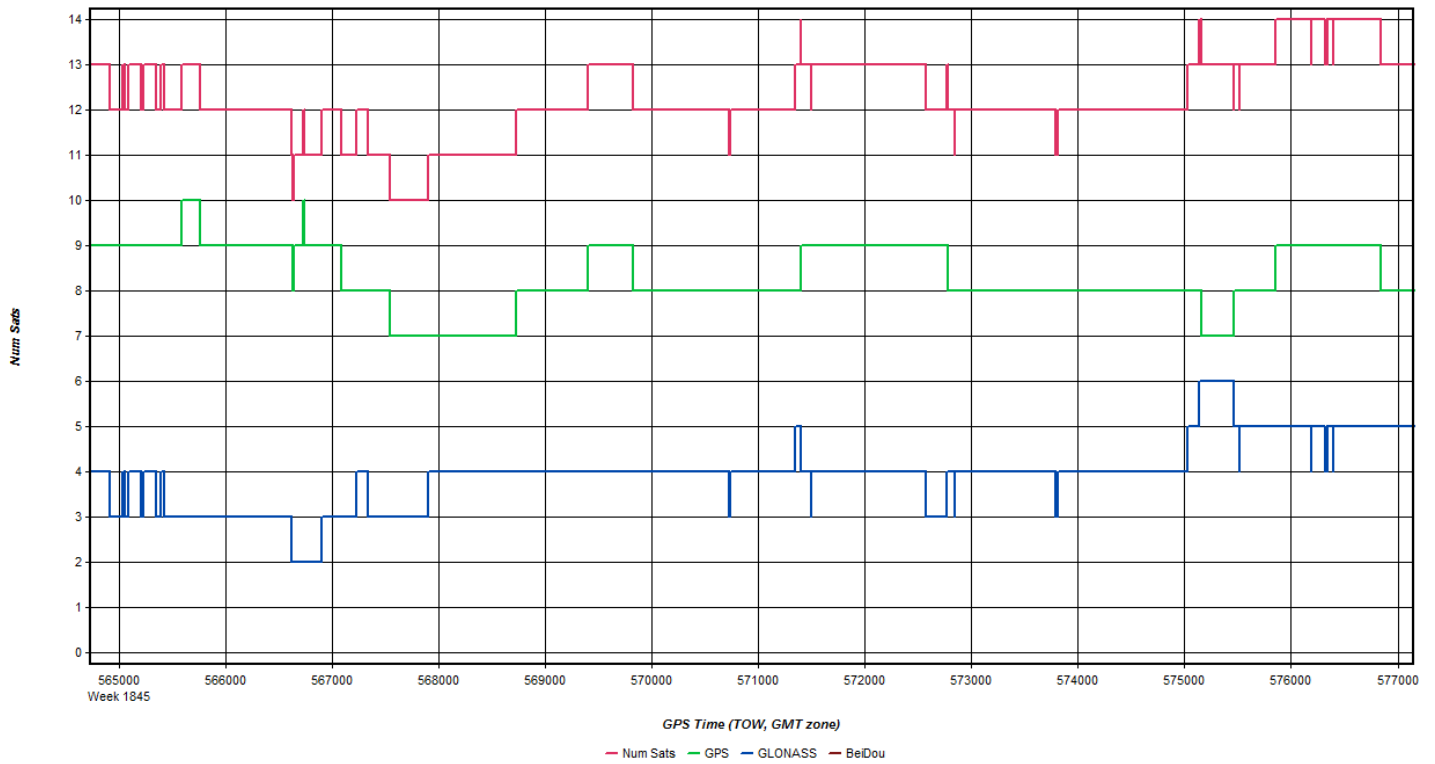

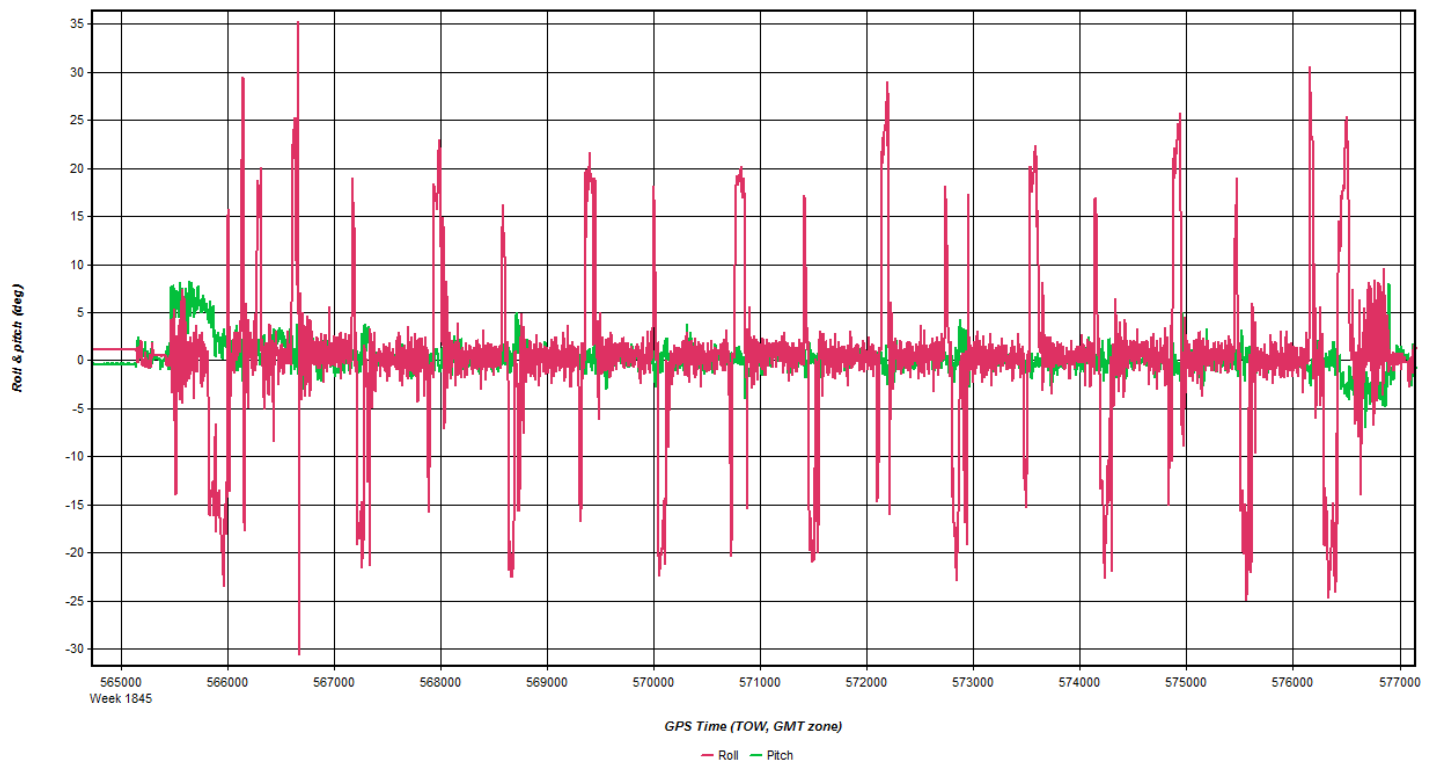
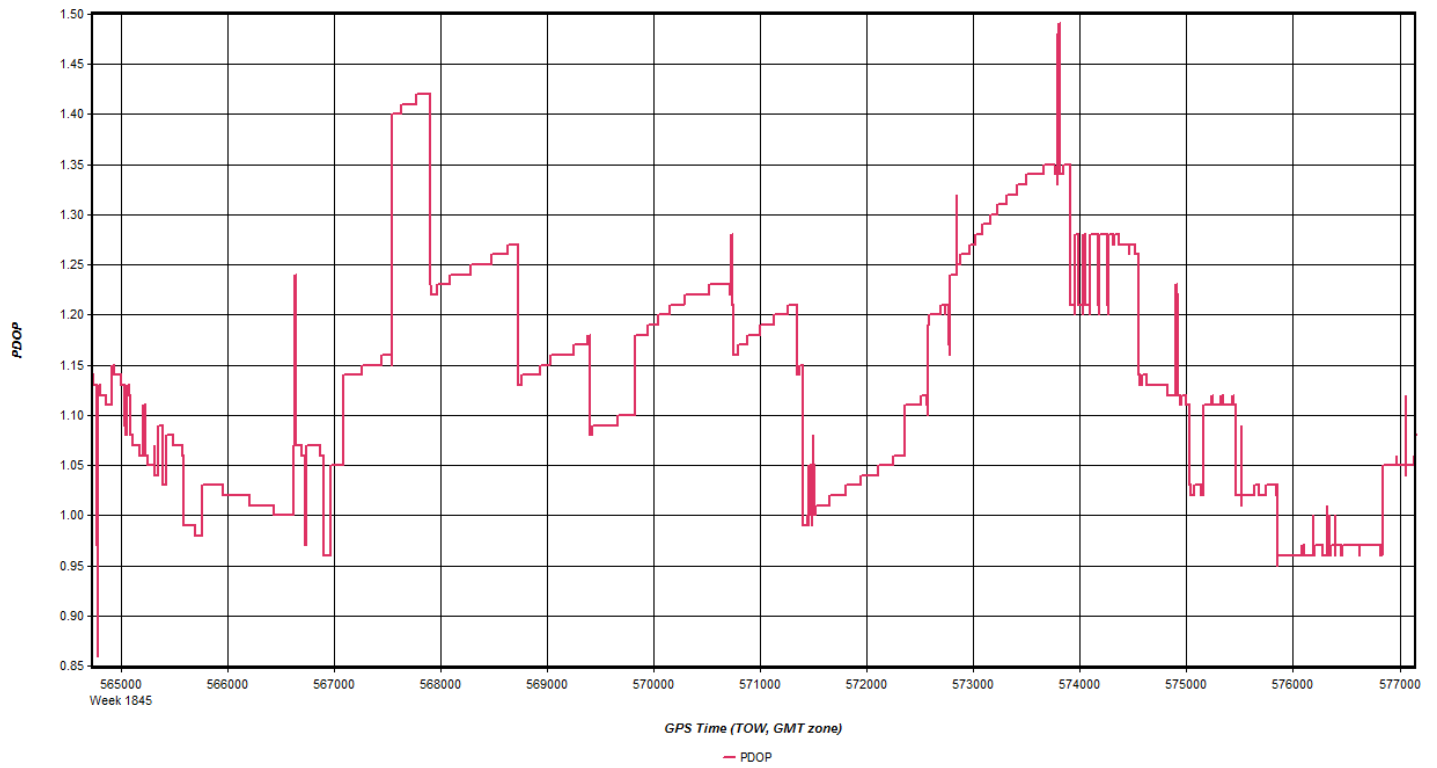

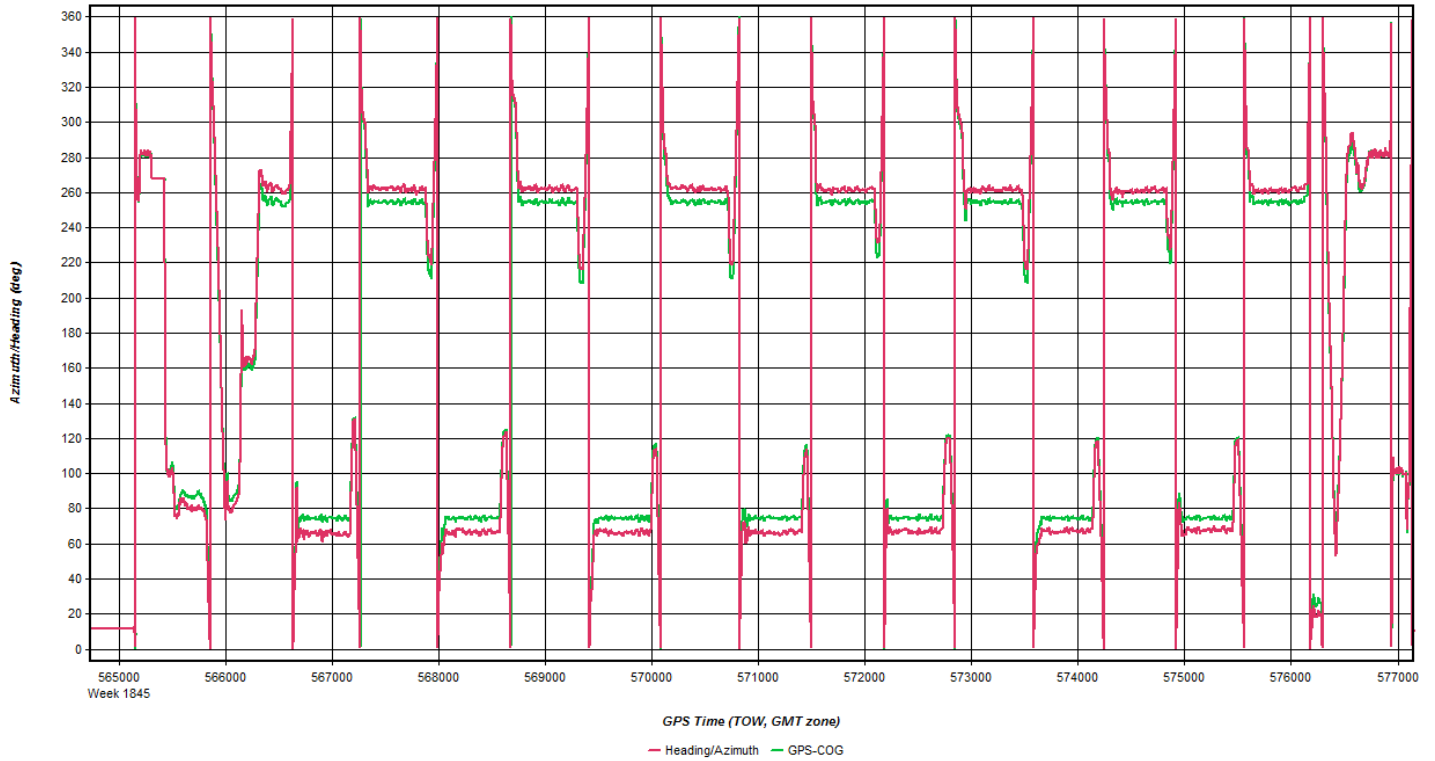

**Coordinate/Antenna Settings**

Master Remote

Base Station  
 2: CHES Name: CHES  Disabled  
 File: D:\Proc\20150523\_26236\_Brandwine\_reflights\_8239\_22GE\2015

Coordinates  
 Latitude: North 39 57 05.91984   
 Longitude: West 75 36 01.15234   
 Ellipsoidal height: 109.439 m   
 Datum: NAD83(2011)

Antenna Height  
 From station file: TRM41249.00, NONE   
 Antenna profile: TRM41249.00   
 Measured height: 0.000 m  
 ARP to L1 offset: 0.056 m  
 Applied height: 0.056 m  
 Measured to:  
 ARP  
 L1 Phase Centre

Coordinate/Antenna Settings

Master Remote

Base Station  
1: PAPH Name: PAPH  Disabled  
File: D:\Proc\20150523\_26236\_Brandwine\_reflights\_8239\_22GE\2015

Coordinates  
Latitude: North 40 00 47.34854 Compute from PPP  
Longitude: West 75 10 34.78766 Enter Grid Values  
Ellipsoidal height: 27.809 m Enter MSL Height  
Datum: NAD83(2011) Datum Options  
Select From Favorites Add To Favorites Use Average Position

Antenna Height  
From station file: LEIAX1202GG, NONE View STA File  
Antenna profile: LEIAX1202GG Info

Measured height: 0.000 m  
ARP to L1 offset: 0.063 m  
Applied height: 0.063 m

Measured to  
 ARP  
 L1 Phase Centre  
Compute From Slant

OK Cancel



# Flight Log

Scanned by CamScanner

### OPERATORS FLIGHT LOG

MISSION: S 150523 1249524		DATE: 5-23-15		LEICA ALS: 70		8239			
PILOT: B AHILIPS		OPERATOR: M AUST		AIRCRAFT: 226E		REMARKS			
PROJECT NUMBER	LINE NO. & Hdg	GND SPEED (KTS)	FREQ Hz	SCAN ANGLE	PRF KHZ	FIXED GAIN	ALT (m)	TIME START STOP	MM70 DRIVE
26236			62	24	484				
BANDYLINE	7015 173°	141					5730	1316 1317	CROSSHAIR
REFLIGHTS	7014 86°	140					5580	1324 1332	
	7013 266°	143					5850	1336 1344	
	7012 86°	143					5835	1348 1355	
	7011 266°	138					5760	1359 1407	
	7010 86°	145					5875	1411 1419	
	7009 266°	138					5820	1423 1431	
	7008 86°	144					5840	1434 1443	
	7007 266°	143					5875	1446 1454	
	7006 86°	141					5865	1457 1505	ATC ALTITUDE RESTRICTED
	7005 266°	139					5860	1509 1577	ATC ALTITUDE RESTRICTED
	7004 86°	144					5860	1521 1528	
	7003 266°	135					5700	1532 1539	
	7002 86°	140					5760	1543 1550	
	7001 266°	146					5890	1554 1601	
STATUS	TOTAL LINES	FLOWN	LEFT	SITE	AIRCRAFT	FERRY	STATIC	START STOP	NOTES
○ COMPLETE	15	15	0	KMGAS	n/a		5 min	9:00 12:20	BASE STATION AT
○							WX CLEAR		KOCQ - FLY OVER
○							SMOOTH		

AERO-METRIC, INC. N.6216 Resource Drive Sheboygan Falls, WI. 53085 PHONE: 920-467-2655 FAX: 888-253-6695 E-Mail: amephot@aerometric.com

**Nov 25, 2015-A  
(N22GE, SN7178)**

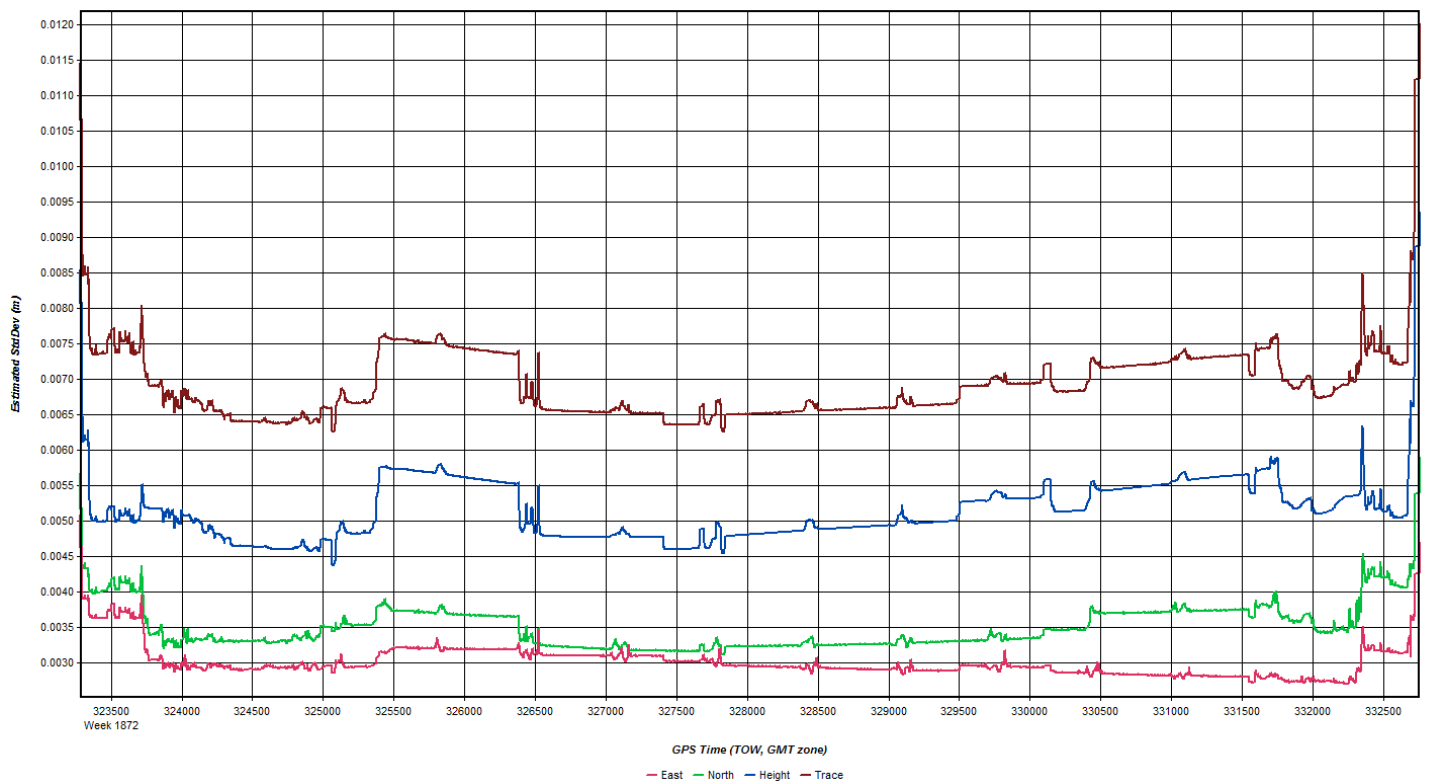
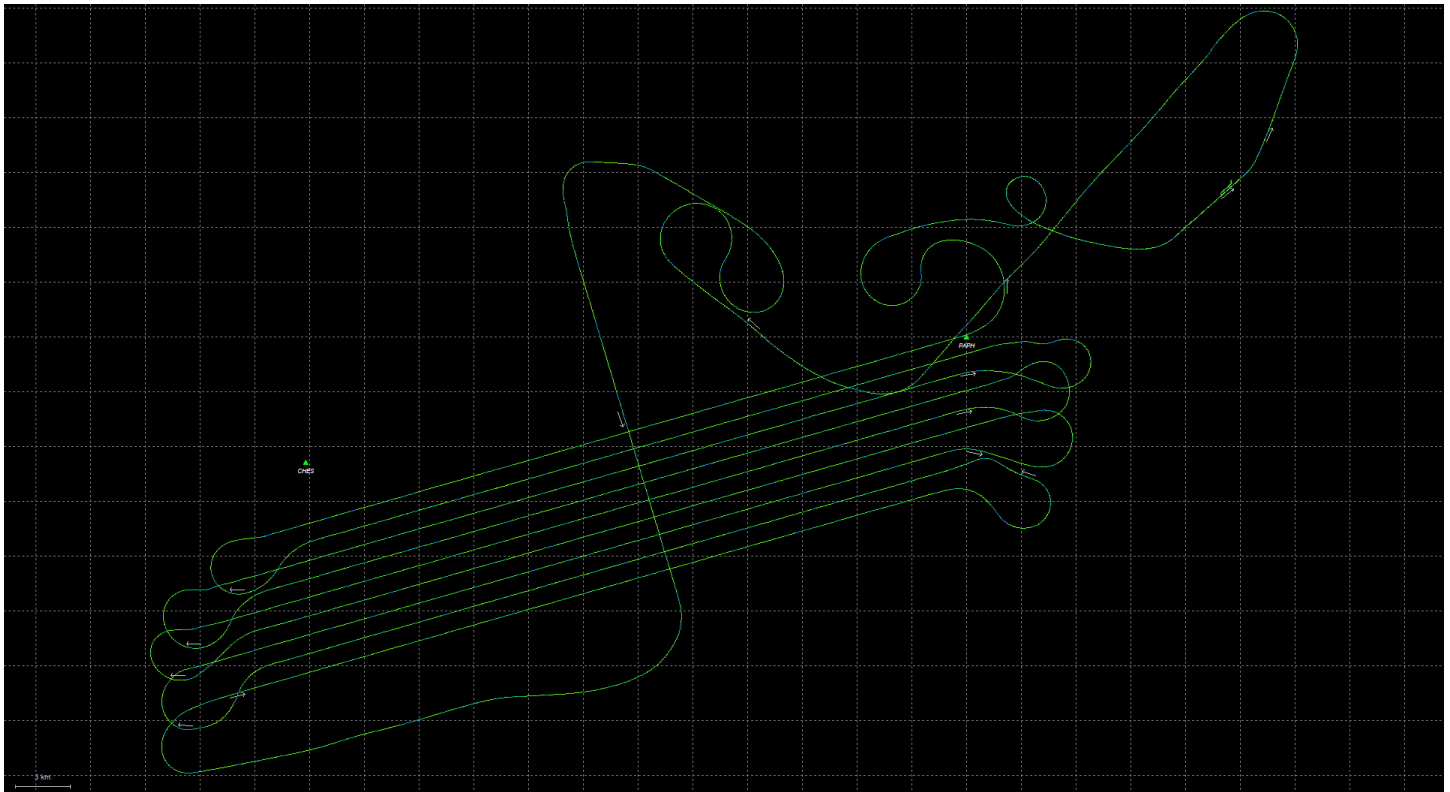

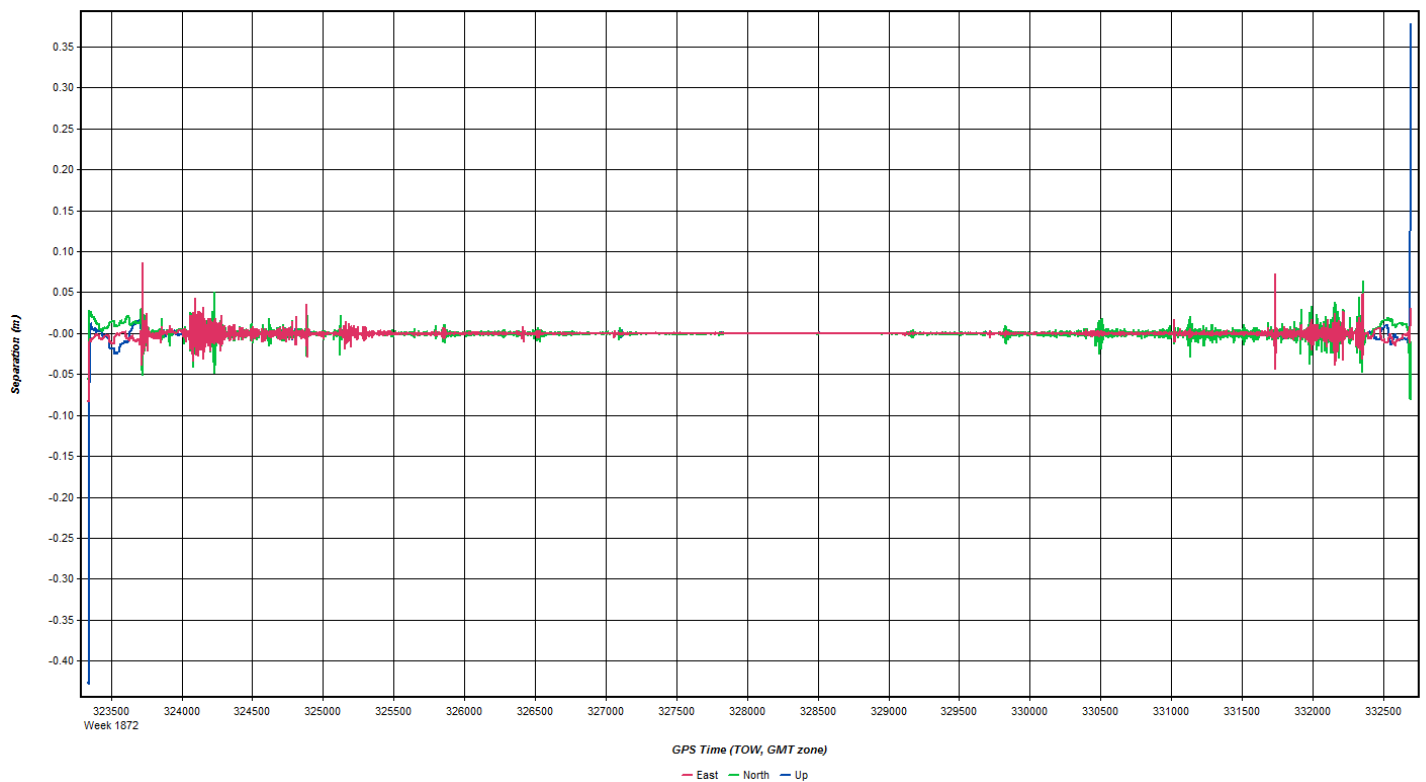
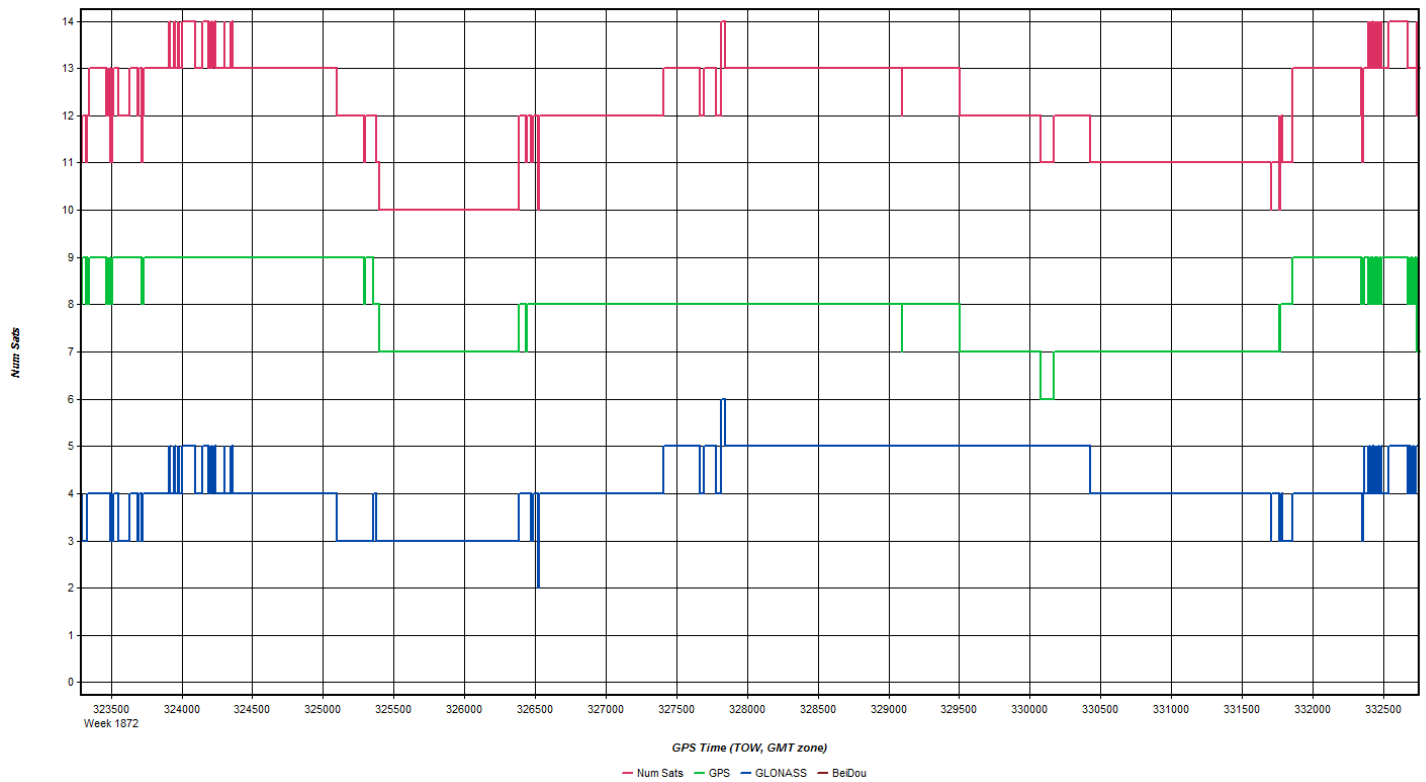

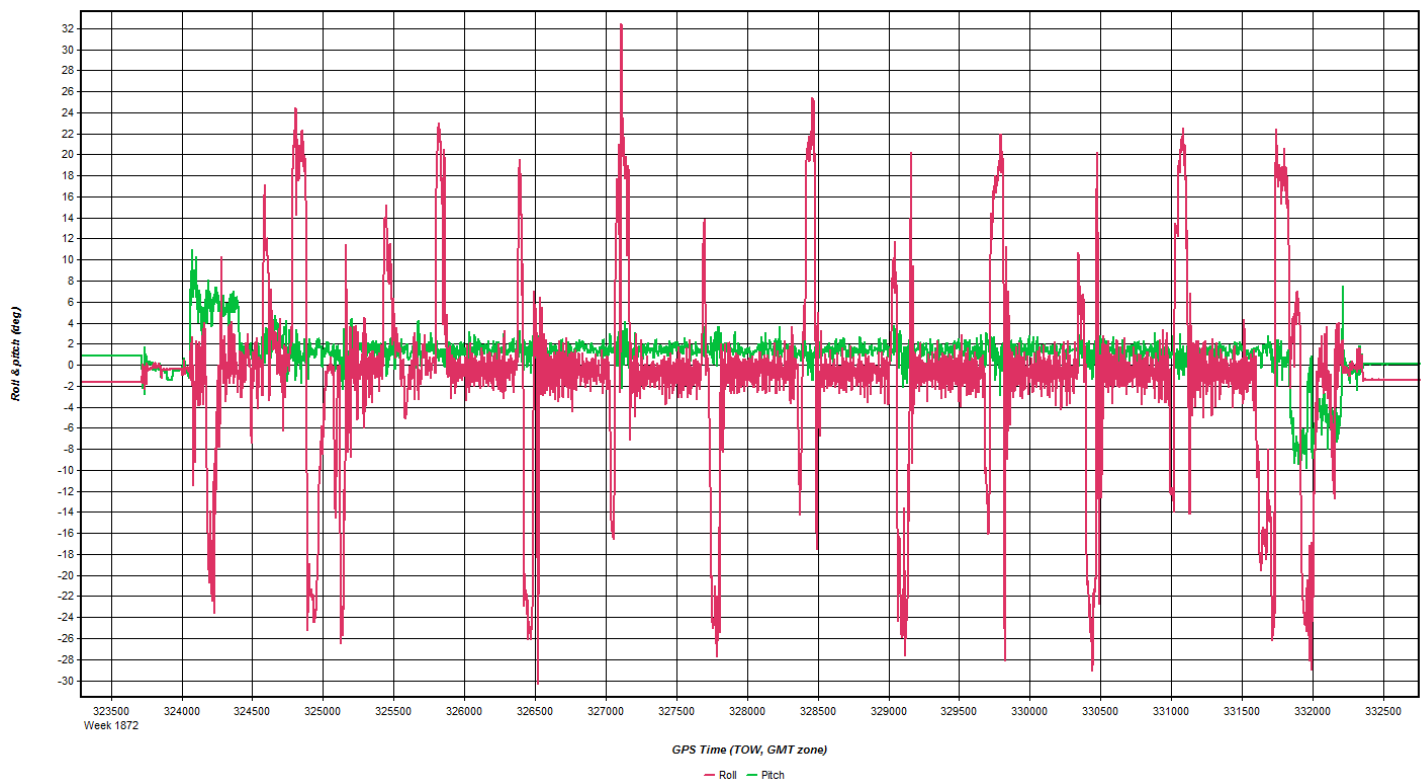
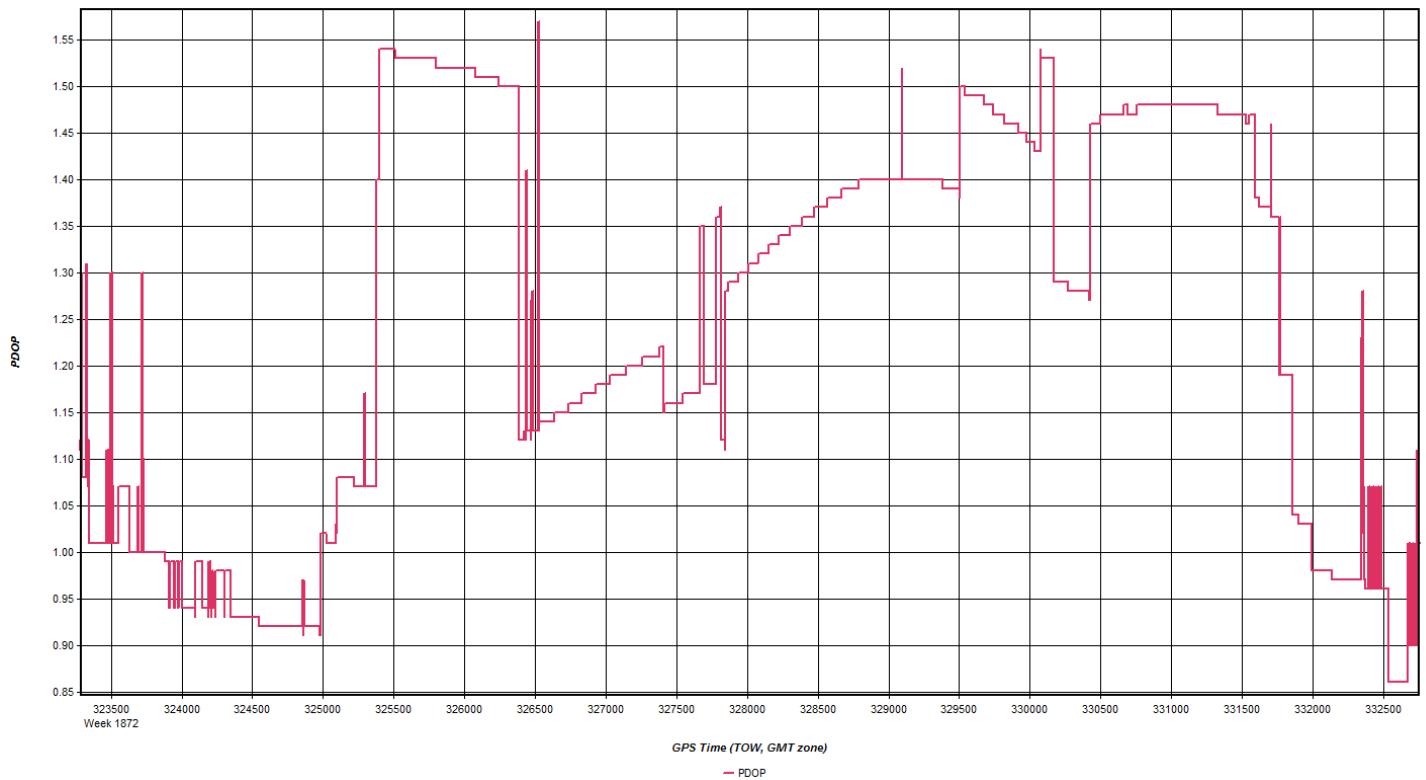

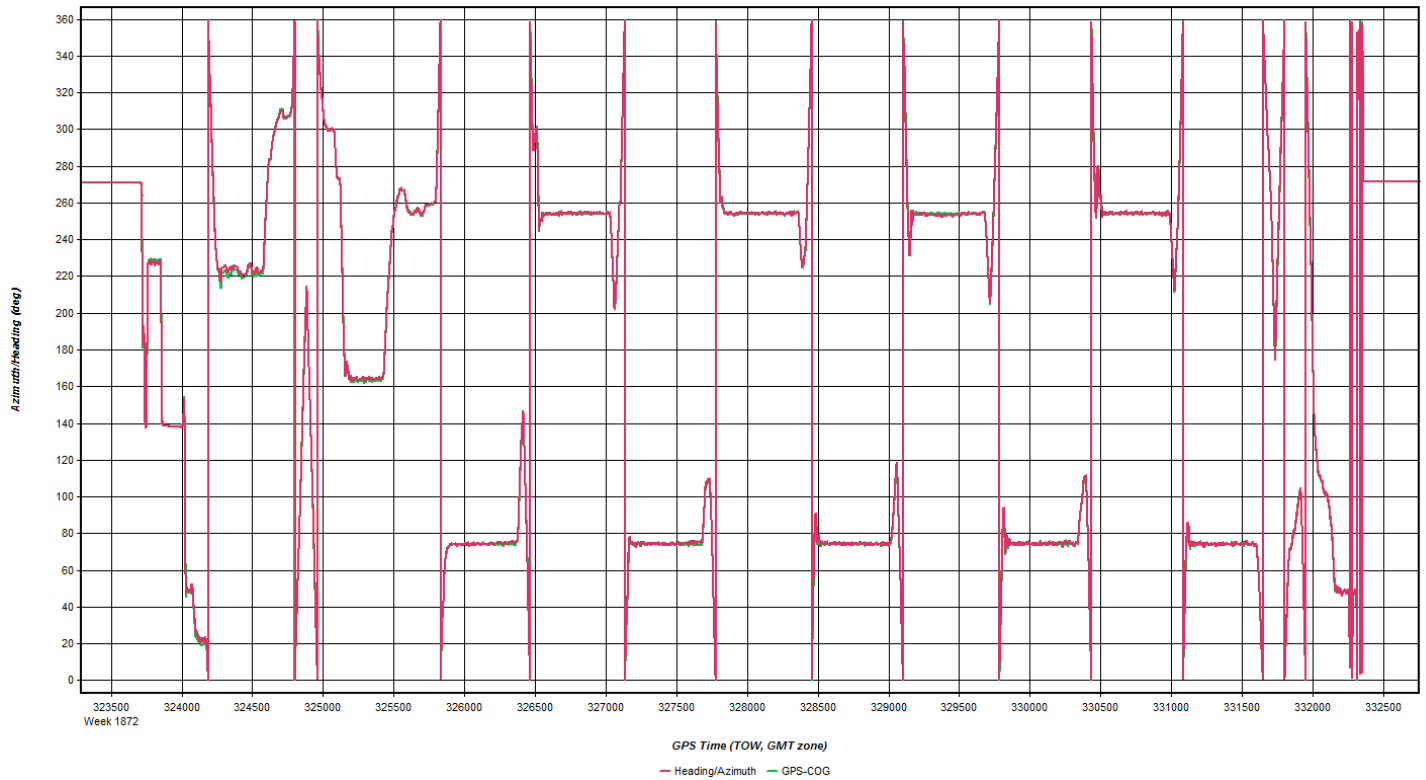

**Coordinate/Antenna Settings**

Master Remote

Base Station  
 2: CHES Name: CHES  Disabled  
 File: S:\LIDAR\26236\_DVRPC\RawData\LN50\20151125\_A\_17422\

Coordinates  
 Latitude: North 39 57 05.91984 Compute from PPP  
 Longitude: West 75 36 01.15234 Enter Grid Values  
 Ellipsoidal height: 109.439 m Enter MSL Height  
 Datum: NAD83(2011) Datum Options  
 Select From Favorites Add To Favorites Use Average Position

Antenna Height  
 From station file: TRM41249.00, NONE View STA File  
 Antenna profile: TRM41249.00 Info

Measured height: 0.000 m  
 ARP to L1 offset: 0.056 m  
 Applied height: 0.056 m

Measured to  
 ARP  
 L1 Phase Centre  
 Compute From Start

OK Cancel

Coordinate/Antenna Settings

Master Remote

Base Station  
1: PAPH Name: PAPH  Disabled  
File: S:\LIDAR\26236\_DVRPC\RawData\LNSO\20151125\_A\_17422

Coordinates  
Latitude: North 40 00 47.34854 Compute from PPP  
Longitude: West 75 10 34.78766 Enter Grid Values  
Ellipsoidal height: 27.809 m Enter MSL Height  
Datum: NAD83(2011) Datum Options  
Select From Favorites Add To Favorites Use Average Position

Antenna Height  
From station file: LEIAX1202GG, NONE View STA File  
Antenna profile: LEIAX1202GG Info  
Measured height: 0.000 m  
ARP to L1 offset: 0.063 m  
Applied height: 0.063 m  
Measured to:  
 ARP  
 L1 Phase Centre  
Compute From Slant

OK Cancel



# Flight Log



# Base Station Log

### GPS OBSERVATION LOG

Station ID	<u>Jet C Hub</u>	Date	<u>11, 25, 2015</u>
Project Number	<u>26236</u>	Julian Date	<u>329</u>
Project Name	<u>USGS-DVRPC</u>	Start Time	<u>:17:19: UTC</u>
Rcvr. Type	<u>Novatel DL-V3</u>	Stop Time	<u>:20:37: UTC</u>
Rcvr. S/N	<u>NBV 12130008</u>	Rcvr. File Name	<u>00083290.PDC</u>
Antenna Type	<u>Novatel GPS-702-66</u>	Observer	<u>DI</u>
Antenna S/N	<u>NAE12110035</u>		

New or Existing Mon.  New  Existing

Photo Taken:  Yes  No

Monument Type: Wood Hub

Spike  PK Nail  AM Washer

Other Wood Hub

Height Readings:  
(Top of Monument to Bottom of Ground Plane)

Start 1.5 M. \_\_\_\_\_ Ft.

Stop 1.5 M. \_\_\_\_\_ Ft.

Mean \_\_\_\_\_ M. \_\_\_\_\_ Ft.

Flush with ground

K PNE Airport  
Jet Center

Monument Sketch and Notes:

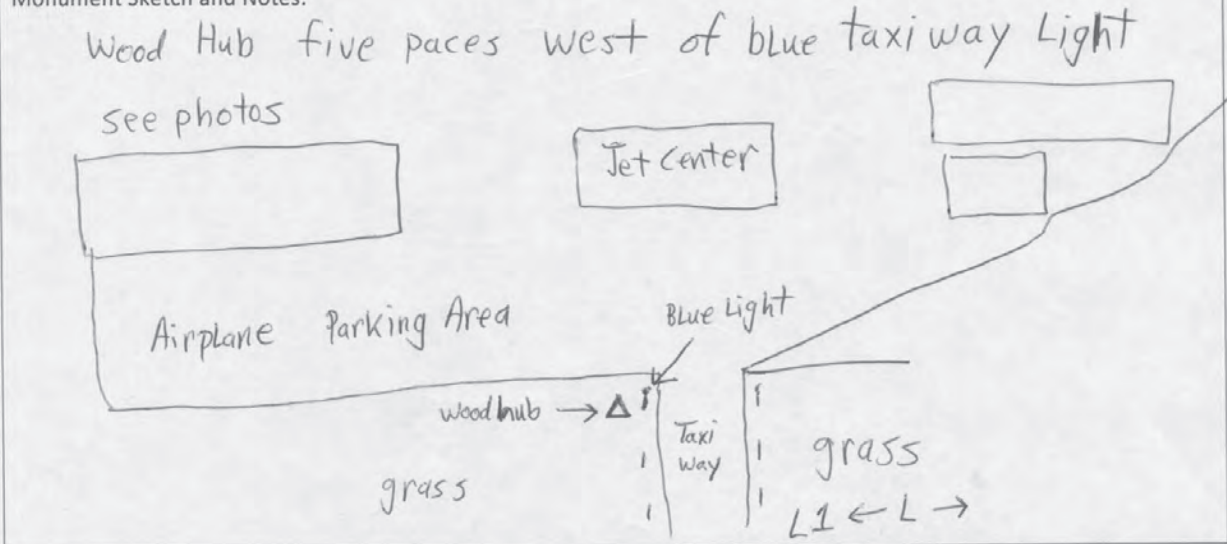

● Taxiway

Jet C Hub 26236 USGS-DVRPC KPNE Airport  
Northeast Philadelphia Airport  
Wood Hub pounded flush w/ ground



## Appendix B

# Survey Report



September 29, 2015

**Survey Report** of  
LiDAR Ground Control & Quality Control  
Points

Delaware Valley High Density  
USGS Contract: G10PC00026  
USGS Task Order: G15PD00316

Presented to:



Presented By:





# CONTENTS OF REPORT

<b>PROJECT INTRODUCTION.....</b>	<b>1</b>
<b>AOI &amp; POINT LOCATION MAPS.....</b>	<b>5</b>
<i>CALIBRATION.....</i>	<i>6</i>
<i>NVA – BARE EARTH.....</i>	<i>7</i>
<i>NVA – URBAN AREA.....</i>	<i>8</i>
<i>VVA – FORESTED.....</i>	<i>9</i>
<i>VVA – TALL WEEDS.....</i>	<i>10</i>
<i>HORIZONTAL CHECK POINTS.....</i>	<i>11</i>
<b>FINAL POINT COORDINATES.....</b>	<b>12</b>
<i>CALIBRATION.....</i>	<i>13</i>
<i>NVA – BARE EARTH.....</i>	<i>16</i>
<i>NVA – URBAN AREA.....</i>	<i>17</i>
<i>VVA – FORESTED.....</i>	<i>20</i>
<i>VVA – TALL WEEDS.....</i>	<i>22</i>
<i>HORIZONTAL CHECK POINTS.....</i>	<i>24</i>
<b>POINT DATA &amp; ACCURACY LOG SHEETS.....</b>	<b>26</b>
<i>CALIBRATION LOG SHEETS.....</i>	<i>27</i>





<b><i>NVA LOG SHEETS.....</i></b>	<b>104</b>
<b><i>BARE EARTH.....</i></b>	<b>105</b>
<b><i>URBAN AREA.....</i></b>	<b>116</b>
<b><i>VVA LOG SHEETS.....</i></b>	<b>198</b>
<b><i>FORESTED.....</i></b>	<b>199</b>
<b><i>TALL WEEDS.....</i></b>	<b>235</b>
<b><i>HORIZONTAL CHECK POINT LOG SHEETS.....</i></b>	<b>271</b>



## Introduction

Quantum Spatial, Inc was contracted by USGS under task order G15PD00248 to survey LiDAR calibration and quality control points in support of the Delaware Valley High Density aerial LiDAR acquisition project. This is the report of the technical approach used and detail of each point surveyed.

## Project Area

The Project Area, shown in the figure below, consists of approximately 7,863 square kilometers.

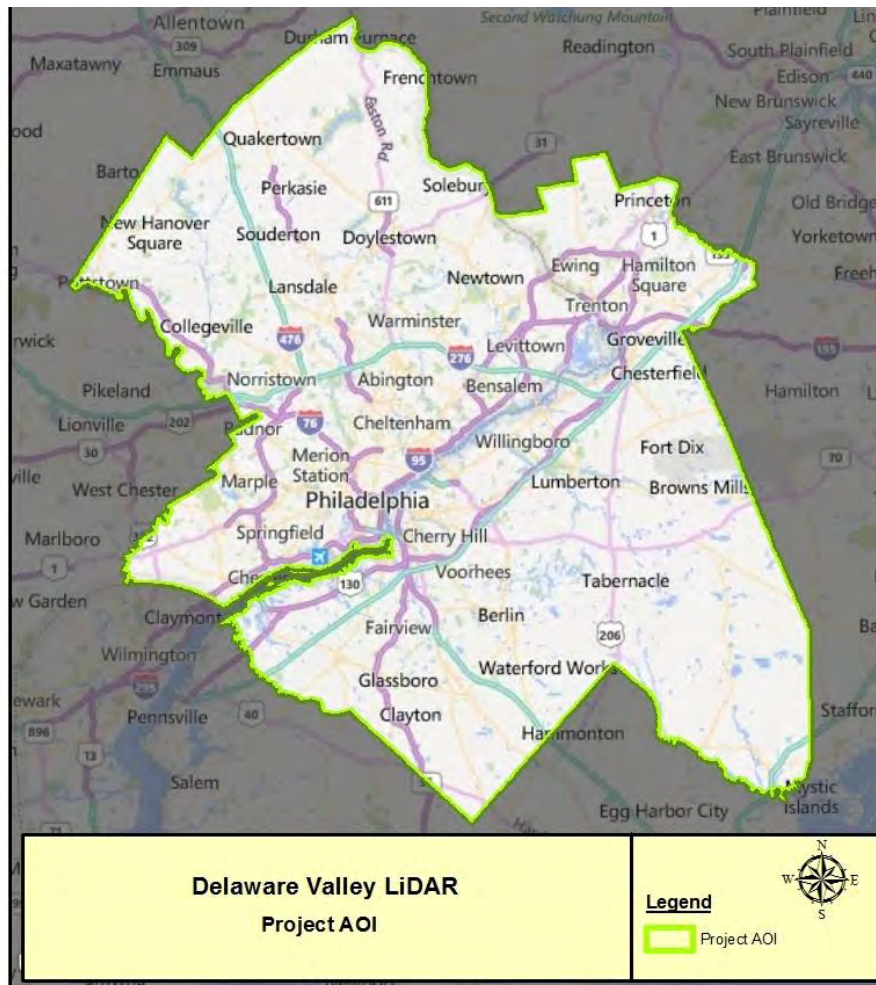



---

## Technical Approach to Land Cover Validation Point Selection

---

Referencing ASPRS Positional Accuracy Standards for Digital Geospatial Data (Edition 1, Version 1.0, - November, 2014) table C.1 Recommended Number of Checkpoints based on Area, Quantum Spatial calculated that 90 Non-Vegetated Vertical Assessment (NVA) and 68 Vegetated Vertical Assessment (VVA) points are required for this project area.

To ensure that checkpoints were distributed generally proportionate among the various vegetated land cover types, Quantum Spatial used existing USGS Land Cover data to divide both the NVA and VVA categories among the various types, calculating the approximate number of required points in each representative type proportionate to the total project area. The resulting point classes are detailed below:

<u>NVA Class</u>	<u># of Points</u>	<u>VVA Class</u>	<u># of Points</u>
Bare Earth	10	Tall Weeds/Crops	34
Urban Area	80	Forested	34

Given that approximately 1/2 of the NVA check points should also be used for horizontal accuracy testing, but that it is commonly understood that good vertical check points do not generally make for good horizontal check points, Quantum Spatial has determined that 45 horizontal check points shall be used for this project, whether they are used for NVA validation, or are entirely separate. These locations have been reported under their own chapter in this report.

Quantum Spatial has adopted the philosophy that each vegetative class must be well distributed throughout the project area. While points in varying classes may be near to one another, points of a single vegetative class may not. Proposed point locations are selected with this distribution methodology in mind.

---

## Survey Accuracy Requirements

---

Given that the survey accuracy of calibration and quality control check points should be 3 times more accurate than the required accuracy of the data set, Quantum Spatial requires that calibration and NVA points be better than 3 centimeters, both horizontally and vertically, and that VVA points be better than 5 centimeters, both horizontally and vertically. The surveyed accuracy of each point must be determined through redundant measurements and/or network adjustment using procedures and methodologies that reliably and consistently result in the aforementioned accuracies. The accuracy of each



point is reported at the 95% confidence level, meaning that if the point were measured 20 times, statistically it would fall within the reported accuracy 19 times.

Due to variances in reference control accuracy and adjustment, Quantum Spatial requires that the survey methodology used be explained, so that it can be repeated if necessary.

---

## Field Survey Methodology

---

### **Date Range:**

April 21 – June 15, 2015

### **Equipment Used:**

Trimble R8 dual frequency GNSS receivers and a Trimble M3 2" Total Station

### **GNSS Methodology:**

Each calibration point was measured using the real time adjusted network provided by Key Net. Each point was measured twice, for at least 8 minutes, separated by a 20 minute static session to ensure variance in the observed satellite constellations. The static base station data was post processed referencing NGS continuously operating reference stations and a weighted adjustment was performed to obtain base station coordinates. The adjustment was performed using Trimble Business Center.

The majority of the QC points were established with calibration point locations occupied by a static base station broadcasting real time kinematic corrections to a rover from which multiple measurements were taken.

For forested points, a secondary control point with line of sight to another point was established so that the resulting pair could be occupied with a total station.

### **Variations from the stated GNSS methodology:**

Due to the reliability of the regional cellular coverage, no alternate methodologies were required for the supplemental portion of this project.

### **Total Station Methodology:**

Angles and distances to forested points were doubled and the final point accuracy was determined by adding the calculated error, estimated procedural errors, and manufacturer stated instrument error to the reported error of the point over which the total station was placed.

---

## Overall Project Accuracy Statement



---

All point coordinates have been reported in the North American Datum of 1983 (NAD83 2011), UTM Zone 18N in meters. Elevations are relative to the North American Vertical Datum of 1988 (NAVD 88) which were derived using the Geoid 12A model and are reported in meters.

#### Calibration Points

Average Horizontal RMSE at the 95% confidence level is 0.008 meter.

Average Elevation RMSE at the 95% confidence level is 0.010 meter.

Average 3 dimensional RMSE at the 95% confidence level is 0.013 meter.

#### NVA Points

Average Horizontal RMSE at the 95% confidence level is 0.013 meter.

Average Elevation RMSE at the 95% confidence level is 0.014 meter.

Average 3 dimensional RMSE at the 95% confidence level is 0.019 meter.

#### VVA Points

Average Horizontal RMSE at the 95% confidence level is 0.013 meter.

Average Elevation RMSE at the 95% confidence level is 0.014 meter.

Average 3 dimensional RMSE at the 95% confidence level is 0.019.



## **PROJECT AOI & POINT MAPS**

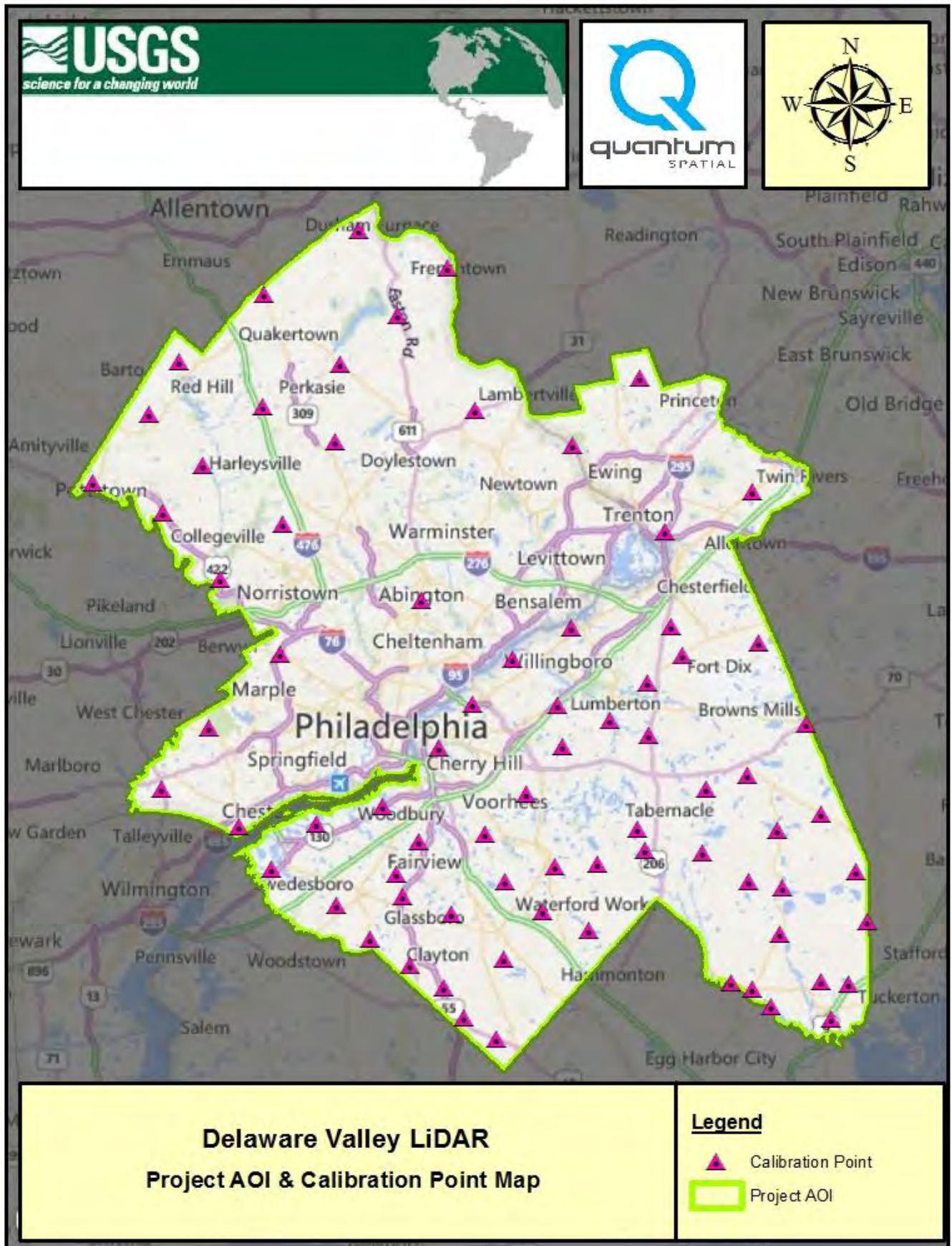





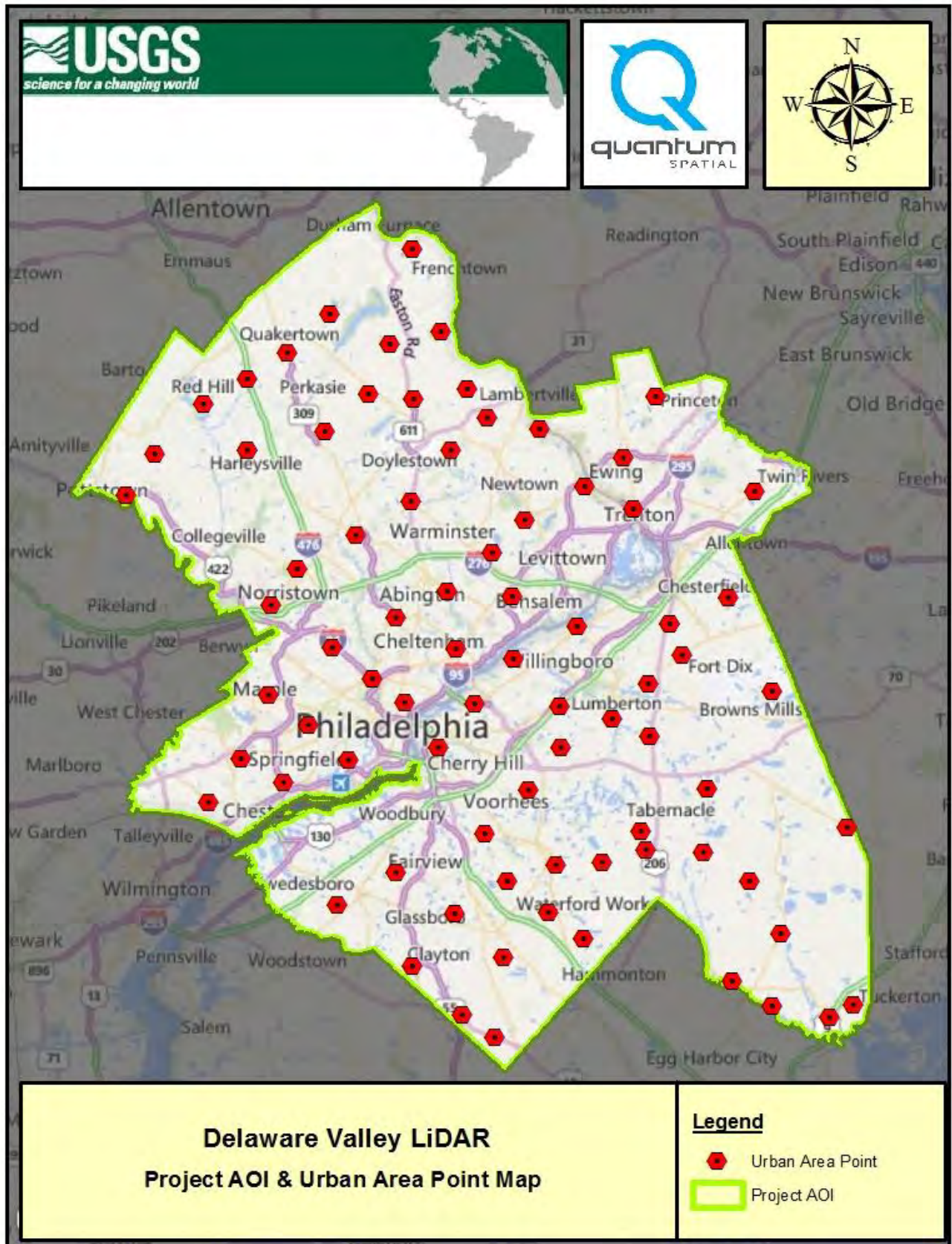

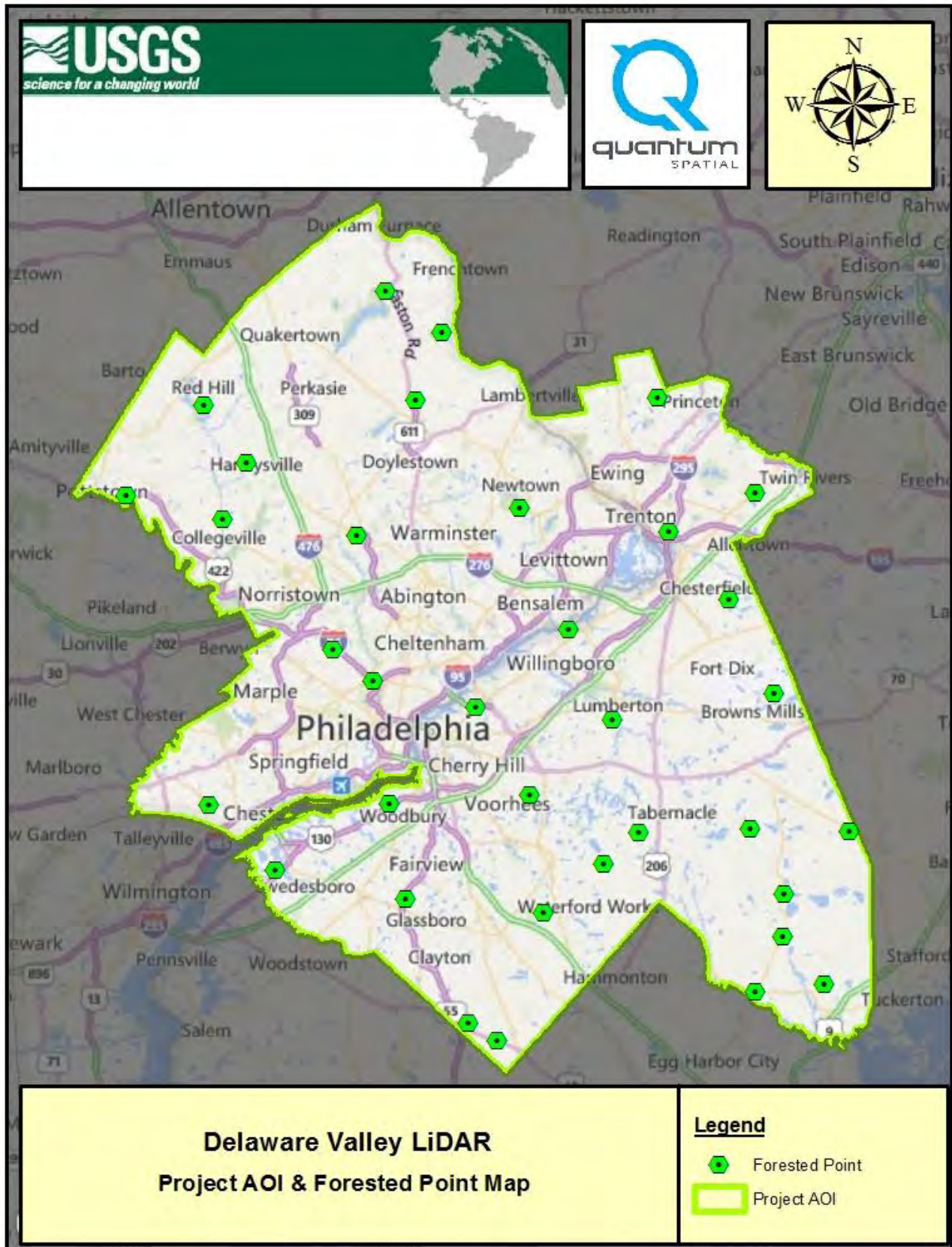

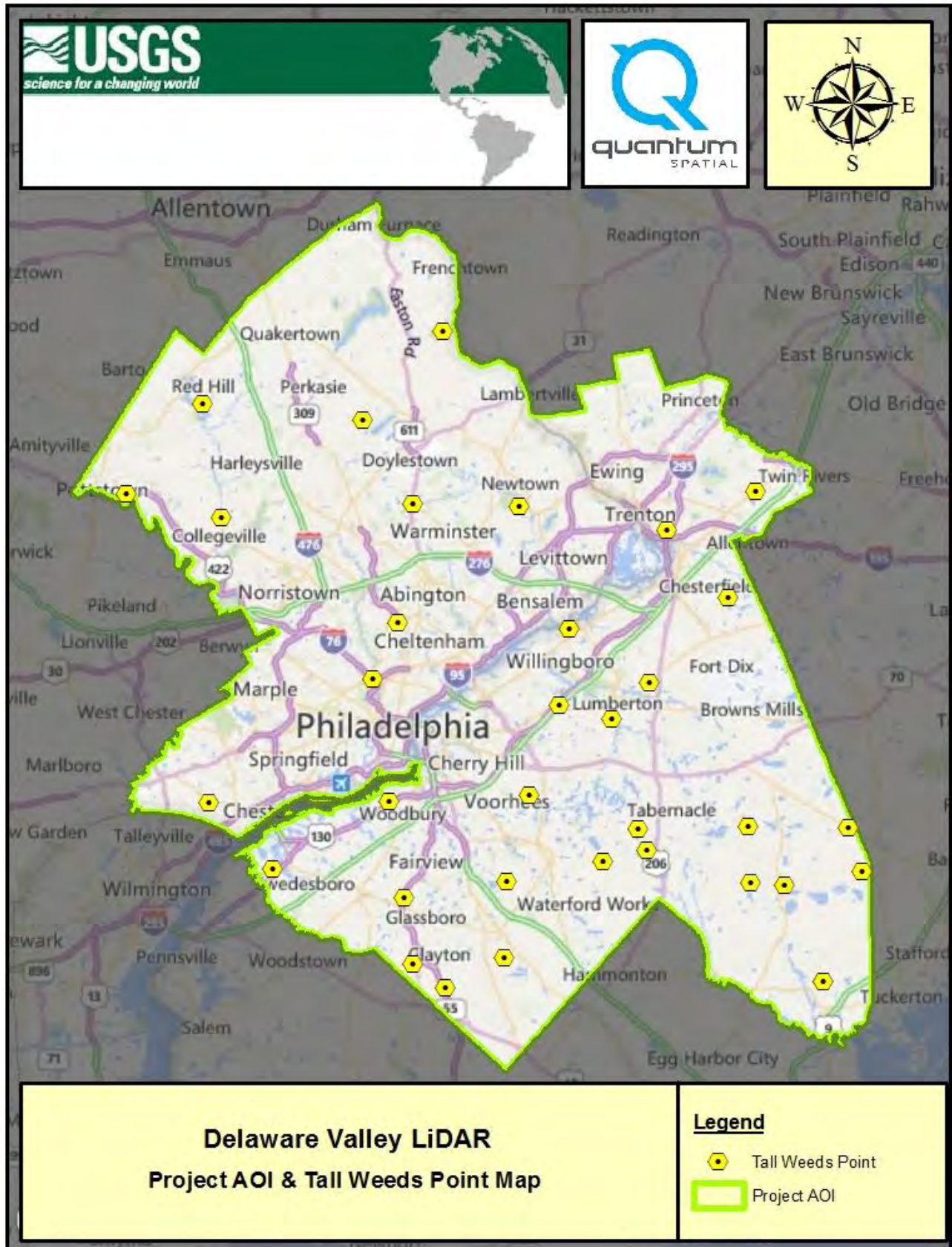

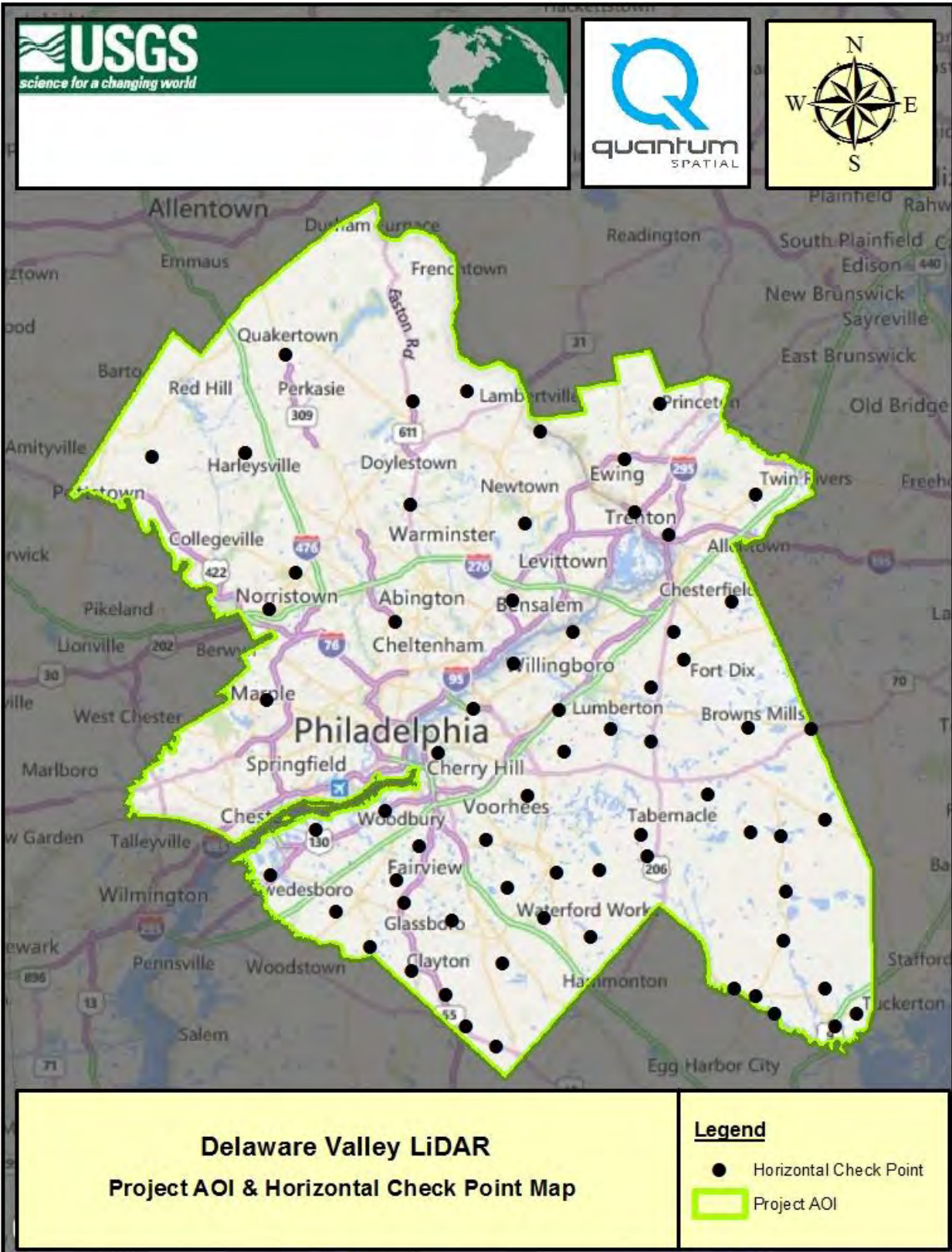



## FINAL POINT COORDINATES



### CALIBRATION POINT COORDINATES

Horizontal Datum - NAD83(2011)  
SPCS UTM-Zone 18N  
Vertical Datum - NAVD 88  
Geoid - GEOID12A  
Units – Meters

Point ID	Northing	Easting	Elevation
CP1	4491359.725	481038.524	79.112
CP3	4482528.392	467694.603	182.372
CP4	4473101.209	455823.976	92.559
CP5	4465722.252	451577.950	111.008
CP6	4456080.620	443701.254	44.089
CP7	4451794.690	453614.676	71.352
CP8	4458489.481	459161.520	62.676
CP9	4466793.715	467473.999	170.161
CP10	4472624.504	478424.426	111.772
CP11	4479529.283	486508.645	99.194
CP12	4486141.795	493490.421	114.605
CP13	4466241.908	497298.860	89.726
CP14	4461772.152	477628.902	162.461
CP15	4450278.078	470332.839	72.744
CP16	4442680.416	461616.052	28.426
CP17	4413135.054	453340.498	117.800
CP18	4421846.578	460055.026	128.586
CP19	4432094.751	469970.839	119.865
CP20	4439610.343	489850.101	51.795
CP21	4461326.146	510943.784	13.987
CP22	4470732.766	520437.688	47.914
CP23	4408028.765	464189.997	8.719
CP24	4380951.771	547150.025	0.853
CP25	4435951.596	524718.155	21.991
CP26	4424856.061	508744.959	12.342
CP27	4401391.789	486309.408	46.251
CP28	4392160.513	482573.781	41.409
CP29	4402389.986	508557.423	50.649
CP30	4433696.916	536981.134	25.016



CP31	4422271.669	543710.144	27.948
CP32	4415104.073	535503.242	28.164
CP33	4404320.072	529108.807	17.008
CP34	4404633.120	521124.203	25.121
CP35	4393488.954	513192.681	30.833
CP36	4385354.158	492983.935	32.668
CP37	4378228.291	500184.559	36.395
CP38	4400182.275	535539.817	17.709
CP39	4409673.574	545754.089	36.250
CP40	4401690.393	550604.308	29.746
CP41	4394697.037	552295.838	40.830
CP42	4386164.427	533160.038	1.399
CP43	4385862.477	549516.693	7.245
CP46	4396862.739	477927.472	33.984
CP47	4401984.706	468823.341	4.596
CP48	4408298.295	475044.910	3.553
CP49	4410827.708	484387.598	7.205
CP50	4405925.259	489382.523	22.361
CP51	4395705.132	493948.654	47.121
CP52	4388571.676	488253.552	41.298
CP53	4381123.053	495727.076	27.612
CP54	4389490.677	501360.315	38.484
CP55	4396120.773	506661.233	47.037
CP56	4402732.969	514450.992	30.399
CP57	4419031.845	492292.670	3.785
CP58	4406835.294	498659.825	20.525
CP59	4400255.068	501435.928	44.318
CP60	4412491.384	504458.737	45.324
CP61	4419128.401	509447.896	21.062
CP62	4425119.704	497012.581	15.108



CP63	4431445.394	502552.149	4.904
CP64	4435809.666	510714.719	1.871
CP65	4431921.989	526383.158	22.003
CP66	4428091.484	521472.954	22.246
CP67	4422816.044	516118.465	14.233
CP68	4420677.102	521622.086	12.566
CP69	4398233.644	487223.130	41.340
CP70	4386236.288	545710.439	10.206
CP71	4382791.887	538730.107	1.657
CP72	4385228.903	536167.920	8.176
CP73	4392906.551	540012.263	13.331
CP74	4399345.399	540309.995	17.119
CP75	4407406.408	539636.263	29.698
CP76	4407646.191	519985.518	32.676
CP77	4413139.146	529675.188	29.901
CP78	4449264.183	523881.137	19.092
CP79	4454891.902	536200.682	31.376





### BARE EARTH POINT COORDINATES

Horizontal Datum - NAD83(2011)  
SPCS UTM-Zone 18N  
Vertical Datum - NAVD 88  
Geoid - GEOID12A  
Units – Meters

Point ID	Northing	Easting	Elevation
BE2	4483119.170	484489.501	159.320
BE9	4447078.997	456848.786	76.790
BE50	4401431.248	486090.221	43.534
BE55	4378310.508	500114.285	36.013
BE58	4402955.310	514904.757	29.966
BE62	4412577.851	504486.140	44.269
BE64	4435705.050	510200.853	3.366
BE67	4422418.173	533612.339	16.614
BE71	4392826.765	539990.878	12.581
BE82	4415848.142	543288.429	38.017



### URBAN AREA POINT COORDINATES

Horizontal Datum - NAD83(2011)  
SPCS UTM-Zone 18N  
Vertical Datum - NAVD 88  
Geoid - GEOID12A  
Units – Meters

Point ID	Northing	Easting	Elevation
UA1	4488869.518	488312.933	184.228
UA3	4479760.044	476838.716	153.667
UA4	4474313.503	470887.945	159.618
UA5	4470616.220	465192.747	164.770
UA6	4467121.945	459090.865	95.900
UA7	4460116.815	452354.114	85.964
UA8	4454400.971	448348.459	46.114
UA11	4460575.453	465279.032	79.962
UA12	4460575.453	465279.032	79.962
UA13	4463274.049	476097.162	189.288
UA14	4468436.400	482299.129	174.635
UA15	4467814.773	488598.764	133.268
UA16	4475550.119	485161.822	120.718
UA17	4477300.860	492446.412	133.086
UA18	4469115.376	496042.754	115.389
UA19	4465221.968	498778.987	73.352
UA20	4460654.382	493806.692	92.756
UA21	4453438.559	488266.593	76.154
UA22	4448792.662	480563.805	97.973
UA23	4443988.473	472236.874	66.375
UA24	4438894.829	468636.543	54.157
UA25	4411248.365	459802.504	68.170
UA26	4417480.712	464377.081	85.307
UA27	4414154.270	470429.007	23.589
UA28	4417195.188	479491.135	1.977
UA29	4422043.968	473787.559	71.443
UA30	4426364.285	468198.199	104.134
UA31	4433016.458	477219.171	105.158
UA32	4428546.166	482724.549	32.220
UA33	4425270.856	487266.892	19.017



UA34	4432828.341	494441.779	33.287
UA35	4437163.405	486177.186	109.915
UA36	4440774.580	493287.031	35.898
UA37	4446198.762	499552.741	31.245
UA38	4440093.360	502310.668	34.782
UA39	4450838.039	504131.849	46.515
UA40	4463539.006	506214.730	24.258
UA41	4455551.738	512549.154	25.012
UA42	4459633.232	518008.585	55.454
UA43	4468127.612	522524.958	74.600
UA47	4452456.872	519400.142	19.107
UA49	4435957.282	511380.153	1.935
UA50	4431398.036	502459.931	4.815
UA51	4425064.161	497037.822	15.155
UA52	4419009.209	492040.067	4.054
UA59	4406889.702	498446.357	17.213
UA60	4413038.487	504591.126	32.952
UA61	4419064.015	509164.841	19.978
UA62	4423022.814	516285.815	13.671
UA63	4427859.884	521484.938	21.148
UA64	4431932.939	526069.751	22.324
UA65	4439978.937	532561.490	29.570
UA66	4426927.489	538769.439	29.896
UA67	4381108.524	546829.511	1.410
UA68	4420493.569	521688.917	11.961
UA70	4407262.358	520357.107	30.842
UA71	4402824.865	514904.447	31.038
UA72	4395840.403	507463.520	42.946
UA73	4400289.607	501725.586	44.133
UA75	4389511.492	501077.997	39.864
UA79	4400228.025	535540.196	17.273



UA83	4407721.364	549285.477	58.861
UA86	4392831.873	540007.719	12.712
UA88	4382792.680	538696.855	1.422
UA91	4382885.539	550166.416	3.886
UA101	4378326.224	499994.459	34.748
UA102	4392173.353	512389.211	35.446
UA103	4402489.139	508447.099	49.814
UA104	4424752.638	508922.168	13.176
UA105	4436293.876	524367.991	22.641
UA106	4436293.876	524367.991	22.641
UA107	4386195.281	533177.792	1.160
UA109	4404577.477	521121.356	24.970
UA110	4404332.578	529105.668	16.945
UA111	4454810.216	536238.904	30.810
NVA56	4396881.766	477852.955	32.082
NVA69	4413143.124	529610.287	29.705
NVA74	4395708.842	494333.292	44.820
NVA76	4388352.625	488420.567	39.986
NVA77	4381620.817	495377.489	31.774
NVA100	4401513.802	486031.316	42.815



### FORESTED POINT COORDINATES

Horizontal Datum - NAD83(2011)  
SPCS UTM-Zone 18N  
Vertical Datum - NAVD 88  
Geoid - GEOID12A  
Units – Meters

Point ID	Northing	Easting	Elevation
FO01A	4392850.431	539950.795	11.805
FO02A	4432990.871	477194.935	104.332
FO03A	4448835.607	480563.636	99.761
FO04A	4402999.811	514886.765	29.680
FO05A	4378351.748	500007.060	34.347
FO06A	4411244.473	459837.455	69.465
FO07A	4459006.563	465093.687	56.823
FO08A	4467819.289	488671.030	136.899
FO09A	4452726.003	503227.353	33.728
FO10A	4428542.428	482767.100	33.187
FO11A	4451151.130	461691.499	34.248
FO12A	4454451.159	448333.516	44.416
FO13A	4467092.705	459083.273	97.661
FO14A	4483076.108	484510.426	159.470
FO15A	4477266.087	492415.797	133.415
FO16	4468118.537	522564.781	74.651
FO17	4454780.149	536197.369	29.670
FO18	4449401.214	524011.950	18.523
FO19	4435696.499	510133.636	3.503
FO20	4425013.081	497090.994	13.071
FO21	4411405.804	485086.466	2.244
FO22	4402115.168	469201.798	1.690
FO23	4398113.571	487270.762	39.004
FO24	4412607.699	504547.197	42.684
FO25	4423109.111	516190.703	12.667
FO26	4439967.031	532507.290	29.084
FO27	4426898.038	538727.570	29.510
FO28	4407511.249	519874.688	31.721
FO29	4396234.932	506624.298	46.255
FO30	4380808.456	496039.040	35.891



FO31	4408037.076	535359.109	33.671
FO32	4407678.700	549315.591	58.132
FO33	4398930.007	540127.971	17.468
FO34	4385254.867	536160.096	7.442
FO35	4386214.005	545688.299	9.793



### TALL WEEDS POINT COORDINATES

Horizontal Datum - NAD83(2011)  
SPCS UTM-Zone 18N  
Vertical Datum - NAVD 88  
Geoid - GEOID12A  
Units – Meters

Point ID	Northing	Easting	Elevation
TW2	4467114.015	459051.233	96.337
TW3	4454423.676	448316.382	43.964
TW4	4451183.356	461655.024	36.899
TW6	4464853.427	481345.363	194.172
TW7	4477270.588	492492.453	131.936
TW9	4453127.795	488418.449	70.437
TW11	4411283.694	459813.053	69.895
TW13	4428557.836	482748.175	31.882
TW14	4436519.713	486276.940	99.431
TW15	4452704.230	503222.820	35.045
TW17	4454892.531	536237.071	31.448
TW18	4449381.488	523923.983	19.343
TW19	4435674.051	510144.652	3.202
TW21	4411403.422	485100.305	2.406
TW22	4401995.831	468814.531	4.853
TW23	4398038.663	487152.110	40.738
TW24	4412367.271	504626.680	46.431
TW25	4423056.246	516234.229	12.769
TW26	4439972.584	532528.321	29.415
TW28	4407530.252	519883.755	31.676
TW29	4402992.902	514932.663	29.248
TW31	4407997.518	535312.527	34.212
TW32	4407709.793	549328.226	58.349
TW33	4399651.701	540309.144	17.219
TW35	4386258.156	545712.700	9.451
TW36	4386258.150	545712.700	9.439
TW51	4385432.086	492920.672	32.314
TW52	4388750.495	488297.344	41.194
TW53	4389522.024	501052.507	39.693
TW55	4400337.781	501462.857	44.409



TW57	4424874.739	508912.191	12.570
TW58	4428125.849	521367.142	22.435
TW101	4400169.252	535578.534	18.634
TW102	4401575.919	551191.053	28.844
TW103	4404580.143	521043.513	25.054



**PHOTO POINT COORDINATES**

Horizontal Datum - NAD83(2011)  
SPCS UTM-Zone 18N  
Vertical Datum - NAVD 88  
Geoid - GEOID12A  
Units – Meters

Point ID	Northing	Easting	Elevation	Feature Code
PP1	4398178.150	487277.559	Hz Only	CL END STOPBAR
PP2	4396873.911	477855.223	Hz Only	COR CONC
PP3	4402008.453	468821.339	Hz Only	CL STOP BAR
PP4	4408338.955	475052.910	Hz Only	TIP ARROW
PP5	4410968.922	484706.676	Hz Only	CRNR STOP BAR
PP6	4405968.887	489378.535	Hz Only	COR SDWK
PP7	4401357.385	486275.508	Hz Only	COR CONC@ASPHALT
PP8	4395660.291	493910.114	Hz Only	TIP OF ARROW
PP9	4385380.533	493061.128	Hz Only	CORN CONC@ASPHALT
PP10	4388744.505	488318.966	Hz Only	CRNR SDWK
PP11	4380979.961	495848.125	Hz Only	CRNR SDWK
PP12	4392010.572	482601.648	Hz Only	CRNR SDWK
PP13	4378279.957	500162.888	Hz Only	CLEND STOPBAR
PP14	4389799.358	501030.179	Hz Only	EP@PVMTCANGE
PP15	4395979.422	506757.865	Hz Only	CL STOPBAR
PP16	4393482.261	513225.082	Hz Only	CRNR SDWK
PP17	4402738.099	514442.960	Hz Only	ASPHALT CHANGE
PP18	4419033.829	491989.664	Hz Only	CLEND STOPBAR
PP19	4406837.553	498644.005	Hz Only	CLEND STOPBAR
PP20	4400302.722	501712.640	Hz Only	CRNR CONC@EP
PP21	4402427.645	508497.297	Hz Only	CRNR SDWK
PP22	4413077.760	504481.794	Hz Only	CORN CONC
PP23	4419233.186	509483.429	Hz Only	CLEND STOPBAR
PP24	4424886.642	508876.565	Hz Only	CL END STOPBAR
PP25	4425063.658	497015.152	Hz Only	PVMT CHANGE
PP26	4431419.982	502529.886	Hz Only	CRNR CONC
PP27	4435802.656	510714.841	Hz Only	CRNR PKIG LOT
PP28	4435822.956	524796.948	Hz Only	CL END STOPBAR
PP29	4431932.173	526065.079	Hz Only	CRNR CONC
PP30	4428033.125	521657.284	Hz Only	CRNR SIDEWALK



PP31	4422373.713	516074.974	Hz Only	CRNR SIDEWALK
PP32	4420514.781	521654.763	Hz Only	TIP ARROW
PP33	4380950.574	547130.742	Hz Only	CL END FOGLINE
PP34	4382850.496	550074.422	Hz Only	CONCRETE CORN
PP35	4386232.414	545747.687	Hz Only	CRNR STOP BAR
PP36	4382802.979	538699.364	Hz Only	CORN CONC
PP37	4385219.074	536174.202	Hz Only	CORN FOG LINE
PP38	4386249.160	533210.512	Hz Only	CORN ASPHALT
PP39	4392881.064	540011.099	Hz Only	CRNR HASH@FL
PP40	4399692.881	540320.818	Hz Only	TIP ARROW
PP41	4407411.835	539623.735	Hz Only	CORNER TENIS COURT
PP42	4404649.557	521126.691	Hz Only	COR CONC
PP43	4407625.902	520150.225	Hz Only	CL END STOPBAR
PP44	4413156.894	529461.940	Hz Only	FL@PVMT CHANGE
PP45	4407977.848	535353.131	Hz Only	CL END FOGLINE
PP46	4449208.851	523985.748	Hz Only	CRNR CONC
PP47	4454789.165	536143.546	Hz Only	CRNR CON DR
PP100	4422282.966	543749.424	Hz Only	TARGET
PP101	4409659.788	545783.659	Hz Only	TIP OF CHEVRON
PP102	4439942.569	532726.226	Hz Only	TARGET
PP103	4422410.105	535120.395	Hz Only	CRNR SIDEWALK
PP104	4467425.138	522820.489	Hz Only	CL CRNR STOPBAR
PP105	4459656.141	518009.289	Hz Only	TIP OF ARROW
PP106	4452470.121	519385.595	Hz Only	TIP OF ARROW
UA4	4474313.503	470887.945	Hz Only	END OF STOPBAR
UA7	4460116.815	452354.114	Hz Only	END OF STOPBAR
UA11	4460575.453	465279.032	Hz Only	TIP OF ARROW
UA12	4460575.453	465279.032	Hz Only	PAINT STRIPE INTERSECTION
UA15	4467814.773	488598.764	Hz Only	END OF PAINT STRIPE
UA18	4469115.376	496042.754	Hz Only	END OF FOGLINE
UA21	4453438.559	488266.593	Hz Only	TIP OF CHEVRON
UA23	4443988.473	472236.874	Hz Only	CENTER OF CUL-DE-SAC
UA24	4438894.829	468636.543	Hz Only	TIP OF ARROW
UA30	4426364.285	468198.199	Hz Only	CENTER OF BASKETBALL COURT
UA35	4437163.405	486177.186	Hz Only	CORNER OF PARKING LINES
UA38	4440093.360	502310.668	Hz Only	CORNER OF CONCRETE APRON
UA39	4450838.039	504131.849	Hz Only	TIP OF ARROW
UA40	4463539.006	506214.730	Hz Only	CORNER OF PARKING LINES



## **POINT DATA & ACCURACY LOG SHEETS**



## **CALIBRATION POINT DATA SHEETS**



Point ID	C1
Project No.	26236
Project Name	DELAWARE VALLEY LiDAR
State	Pennsylvania
County	Bucks
Quad	Riegelsville

	Aerial Target
X	LiDAR Ground Control
	LiDAR QC Point
	New Control
	Photo ID
	Published Control

Coordinate System	
NAD83(2011)	
UTM – Zone 18N	
NAVD88	
GEOID12A	
Meters	

<b>Northing</b>	<b>Easting</b>	<b>Elevation</b>
4491359.725	481038.524	79.112

Operator	Kevin Chapman
Receiver Model	Trimble R-8, Model 3
Receiver S/N	5106461067
Antenna Height	2.000 Meters

Date (MM-DD-YYYY)	04/15/2015
RMSE Hz	N/A
RMSE Z	N/A
GPS Method	Keynet VRS

PHOTOS:





Point ID	C3
Project No.	26236
Project Name	DELAWARE VALLEY LiDAR
State	Pennsylvania
County	Bucks
Quad	Milford Square

	Aerial Target
X	LiDAR Ground Control
	LiDAR QC Point
	New Control
	Photo ID
	Published Control

Coordinate System	
NAD83(2011)	
UTM – Zone 18N	
NAVD88	
GEOID12A	
Meters	

<b>Northing</b>	<b>Easting</b>	<b>Elevation</b>
4482528.392	467694.603	182.372

Operator	Kevin Chapman
Receiver Model	Trimble R-8, Model 3
Receiver S/N	5106461067
Antenna Height	2.000 Meters

Date (MM-DD-YYYY)	04/15/2015
RMSE Hz	N/A
RMSE Z	N/A
GPS Method	Keynet VRS

PHOTOS:





Point ID	C4
Project No.	26236
Project Name	DELAWARE VALLEY LiDAR
State	Pennsylvania
County	Montgomery
Quad	East Greenville

	Aerial Target
X	LiDAR Ground Control
	LiDAR QC Point
	New Control
	Photo ID
	Published Control

Coordinate System
NAD83(2011)
UTM – Zone 18N
NAVD88
GEOID12A
Meters

<b>Northing</b>	<b>Easting</b>	<b>Elevation</b>
4482528.392	467694.603	182.372

Operator	Kevin Chapman
Receiver Model	Trimble R-8, Model 3
Receiver S/N	5106461067
Antenna Height	2.000 Meters

Date (MM-DD-YYYY)	04/18/2015
RMSE Hz	N/A
RMSE Z	N/A
GPS Method	Keynet VRS

PHOTOS:





Point ID	C5
Project No.	26236
Project Name	DELAWARE VALLEY LiDAR
State	Pennsylvania
County	Montgomery
Quad	Sassamansville

	Aerial Target
X	LiDAR Ground Control
	LiDAR QC Point
	New Control
	Photo ID
	Published Control

Coordinate System
NAD83(2011)
UTM – Zone 18N
NAVD88
GEOID12A
Meters

<b>Northing</b>	<b>Easting</b>	<b>Elevation</b>
4465722.252	451577.950	111.008

Operator	Kevin Chapman
Receiver Model	Trimble R-8, Model 3
Receiver S/N	5106461067
Antenna Height	2.000 Meters

Date (MM-DD-YYYY)	04/18/2015
RMSE Hz	N/A
RMSE Z	N/A
GPS Method	Keynet VRS

PHOTOS:







Point ID	C6
Project No.	26236
Project Name	DELAWARE VALLEY LiDAR
State	Pennsylvania
County	Montgomery
Quad	Boyertown

	Aerial Target
X	LiDAR Ground Control
	LiDAR QC Point
	New Control
	Photo ID
	Published Control

Coordinate System	
NAD83(2011)	
UTM – Zone 18N	
NAVD88	
GEOID12A	
Meters	

Northing	Easting	Elevation
4456080.620	443701.254	44.089

Operator	Kevin Chapman
Receiver Model	Trimble R-8, Model 3
Receiver S/N	5106461067
Antenna Height	2.000 Meters

Date (MM-DD-YYYY)	04/18/2015
RMSE Hz	N/A
RMSE Z	N/A
GPS Method	Keynet VRS

PHOTOS:





Point ID	C7
Project No.	26236
Project Name	DELAWARE VALLEY LiDAR
State	Pennsylvania
County	Montgomery
Quad	Phoenixville

Aerial Target	
X	LiDAR Ground Control
	LiDAR QC Point
	New Control
	Photo ID
	Published Control

Coordinate System	
	NAD83(2011)
	UTM – Zone 18N
	NAVD88
	GEOID12A
	Meters

<b>Northing</b>	<b>Easting</b>	<b>Elevation</b>
4451794.690	453614.676	71.352

Operator	Kevin Chapman
Receiver Model	Trimble R-8, Model 3
Receiver S/N	5106461067
Antenna Height	2.000 Meters

Date (MM-DD-YYYY)	04/17/2015
RMSE Hz	N/A
RMSE Z	N/A
GPS Method	Keynet VRS

PHOTOS:





Point ID	C8
Project No.	26236
Project Name	DELAWARE VALLEY LiDAR
State	Pennsylvania
County	Montgomery
Quad	Perkiomenville

	Aerial Target
X	LiDAR Ground Control
	LiDAR QC Point
	New Control
	Photo ID
	Published Control

Coordinate System
NAD83(2011)
UTM – Zone 18N
NAVD88
GEOID12A
Meters

Northing	Easting	Elevation
4451794.690	453614.676	71.352

Operator	Kevin Chapman
Receiver Model	Trimble R-8, Model 3
Receiver S/N	5106461067
Antenna Height	2.000 Meters

Date (MM-DD-YYYY)	04/18/2015
RMSE Hz	N/A
RMSE Z	N/A
GPS Method	Keynet VRS

PHOTOS:





Point ID	C9
Project No.	26236
Project Name	DELAWARE VALLEY LiDAR
State	Pennsylvania
County	Montgomery
Quad	Perkiomenville

	Aerial Target
X	LiDAR Ground Control
	LiDAR QC Point
	New Control
	Photo ID
	Published Control

Coordinate System	
NAD83(2011)	
UTM – Zone 18N	
NAVD88	
GEOID12A	
Meters	

<b>Northing</b>	<b>Easting</b>	<b>Elevation</b>
4466793.715	467473.999	170.161

Operator	Kevin Chapman
Receiver Model	Trimble R-8, Model 3
Receiver S/N	5106461067
Antenna Height	2.000 Meters

Date (MM-DD-YYYY)	05/06/2015
RMSE Hz	0.008
RMSE Z	0.012
GPS Method	Keynet VRS

PHOTOS:





Point ID	C10
Project No.	26236
Project Name	DELAWARE VALLEY LiDAR
State	Pennsylvania
County	Bucks
Quad	Quakertown

	Aerial Target
X	LiDAR Ground Control
	LiDAR QC Point
	New Control
	Photo ID
	Published Control

Coordinate System
NAD83(2011)
UTM – Zone 18N
NAVD88
GEOID12A
Meters

Northing	Easting	Elevation
4472624.504	478424.426	111.772

Operator	Kevin Chapman
Receiver Model	Trimble R-8, Model 3
Receiver S/N	5106461067
Antenna Height	2.000 Meters

Date (MM-DD-YYYY)	04/24/2015
RMSE Hz	0.015
RMSE Z	0.016
GPS Method	Keynet VRS

PHOTOS:





Point ID	C11
Project No.	26236
Project Name	DELAWARE VALLEY LiDAR
State	Pennsylvania
County	Bucks
Quad	Bedminster

	Aerial Target
X	LiDAR Ground Control
	LiDAR QC Point
	New Control
	Photo ID
	Published Control

Coordinate System	
NAD83(2011)	
UTM – Zone 18N	
NAVD88	
GEOID12A	
Meters	

Northing	Easting	Elevation
4479529.283	486508.645	99.194

Operator	Kevin Chapman
Receiver Model	Trimble R-8, Model 3
Receiver S/N	5106461067
Antenna Height	2.000 Meters

Date (MM-DD-YYYY)	04/24/2015
RMSE Hz	0.015
RMSE Z	0.017
GPS Method	Keynet VRS

PHOTOS:





Point ID	C12
Project No.	26236
Project Name	DELAWARE VALLEY LiDAR
State	Pennsylvania
County	Bucks
Quad	Frenchtown

Aerial Target	
X	LiDAR Ground Control
	LiDAR QC Point
	New Control
	Photo ID
	Published Control

Coordinate System	
	NAD83(2011)
	UTM – Zone 18N
	NAVD88
	GEOID12A
	Meters

Northing	Easting	Elevation
4486141.795	493490.421	114.605

Operator	Kevin Chapman
Receiver Model	Trimble R-8, Model 3
Receiver S/N	5106461067
Antenna Height	2.000 Meters

Date (MM-DD-YYYY)	04/24/2015
RMSE Hz	0.015
RMSE Z	0.016
GPS Method	Keynet VRS

PHOTOS:





Point ID	C13
Project No.	26236
Project Name	DELAWARE VALLEY LiDAR
State	Pennsylvania
County	Bucks
Quad	Buckingham

	Aerial Target
X	LiDAR Ground Control
	LiDAR QC Point
	New Control
	Photo ID
	Published Control

Coordinate System	
NAD83(2011)	
UTM – Zone 18N	
NAVD88	
GEOID12A	
Meters	

<b>Northing</b>	<b>Easting</b>	<b>Elevation</b>
4466241.908	497298.860	89.726

Operator	Kevin Chapman
Receiver Model	Trimble R-8, Model 3
Receiver S/N	5106461067
Antenna Height	2.000 Meters

Date (MM-DD-YYYY)	04/24/2015
RMSE Hz	0.014
RMSE Z	0.016
GPS Method	Keynet VRS

PHOTOS:







Point ID	C14
Project No.	26236
Project Name	DELAWARE VALLEY LiDAR
State	Pennsylvania
County	Bucks
Quad	Telford

	Aerial Target
X	LiDAR Ground Control
	LiDAR QC Point
	New Control
	Photo ID
	Published Control

Coordinate System	
NAD83(2011)	
UTM – Zone 18N	
NAVD88	
GEOID12A	
Meters	

Northing	Easting	Elevation
4461772.152	477628.902	162.461

Operator	Kevin Chapman
Receiver Model	Trimble R-8, Model 3
Receiver S/N	5106461067
Antenna Height	2.000 Meters

Date (MM-DD-YYYY)	04/15/2015
RMSE Hz	N/A
RMSE Z	N/A
GPS Method	Keynet VRS

PHOTOS:





Point ID	C15
Project No.	26236
Project Name	DELAWARE VALLEY LiDAR
State	Pennsylvania
County	Montgomery
Quad	Lansdale

	Aerial Target
X	LiDAR Ground Control
	LiDAR QC Point
	New Control
	Photo ID
	Published Control

Coordinate System	
NAD83(2011)	
UTM – Zone 18N	
NAVD88	
GEOID12A	
Meters	

<b>Northing</b>	<b>Easting</b>	<b>Elevation</b>
4450278.078	470332.839	72.744

Operator	Kevin Chapman
Receiver Model	Trimble R-8, Model 3
Receiver S/N	5106461067
Antenna Height	2.000 Meters

Date (MM-DD-YYYY)	04/15/2015
RMSE Hz	N/A
RMSE Z	N/A
GPS Method	Keynet VRS

PHOTOS:





Point ID	C16
Project No.	26236
Project Name	DELAWARE VALLEY LiDAR
State	Pennsylvania
County	Montgomery
Quad	Collegeville

Aerial Target	
X	LiDAR Ground Control
	LiDAR QC Point
	New Control
	Photo ID
	Published Control

Coordinate System	
	NAD83(2011)
	UTM – Zone 18N
	NAVD88
	GEOID12A
	Meters

Northing	Easting	Elevation
4442680.416	461616.052	28.426

Operator	Kevin Chapman
Receiver Model	Trimble R-8, Model 3
Receiver S/N	5106461067
Antenna Height	2.000 Meters

Date (MM-DD-YYYY)	04/17/2015
RMSE Hz	N/A
RMSE Z	N/A
GPS Method	Keynet VRS

PHOTOS:





Point ID	CP17
Project No.	26236
Project Name	DELAWARE VALLEY LiDAR
State	Pennsylvania
County	Delaware
Quad	Wilmington North

Aerial Target	
X	LiDAR Ground Control
	LiDAR QC Point
	New Control
	Photo ID
	Published Control

Coordinate System	
	NAD83(2011)
	UTM – Zone 18N
	NAVD88
	GEOID12A
	Meters

<b>Northing</b>	<b>Easting</b>	<b>Elevation</b>
4413135.054	453340.498	117.800

Operator	Kevin Chapman
Receiver Model	Trimble R-8, Model 3
Receiver S/N	5106461067
Antenna Height	2.000 Meters

Date (MM-DD-YYYY)	05/07/2015
RMSE Hz	0.007
RMSE Z	0.009
GPS Method	Keynet VRS

PHOTOS:





Point ID	CP18
Project No.	26236
Project Name	DELAWARE VALLEY LiDAR
State	Pennsylvania
County	Delaware
Quad	Media

	Aerial Target
X	LiDAR Ground Control
	LiDAR QC Point
	New Control
	Photo ID
	Published Control

Coordinate System
NAD83(2011)
UTM – Zone 18N
NAVD88
GEOID12A
Meters

Northing	Easting	Elevation
4421846.578	460055.026	128.586

Operator	Kevin Chapman
Receiver Model	Trimble R-8, Model 3
Receiver S/N	5106461067
Antenna Height	2.000 Meters

Date (MM-DD-YYYY)	05/08/2015
RMSE Hz	0.010
RMSE Z	0.013
GPS Method	Keynet VRS

PHOTOS:





Point ID	C19
Project No.	26236
Project Name	DELAWARE VALLEY LiDAR
State	Pennsylvania
County	Delaware
Quad	Norristown

	Aerial Target
X	LiDAR Ground Control
	LiDAR QC Point
	New Control
	Photo ID
	Published Control

Coordinate System	
NAD83(2011)	
UTM – Zone 18N	
NAVD88	
GEOID12A	
Meters	

<b>Northing</b>	<b>Easting</b>	<b>Elevation</b>
4432094.751	469970.839	119.865

Operator	Kevin Chapman
Receiver Model	Trimble R-8, Model 3
Receiver S/N	5106461067
Antenna Height	2.000 Meters

Date (MM-DD-YYYY)	05/06/2015
RMSE Hz	0.010
RMSE Z	0.013
GPS Method	Keynet VRS

PHOTOS:





Point ID	CP20
Project No.	26236
Project Name	DELAWARE VALLEY LiDAR
State	Pennsylvania
County	Montgomery
Quad	Frankford

Aerial Target	
X	LiDAR Ground Control
	LiDAR QC Point
	New Control
	Photo ID
	Published Control

Coordinate System	
	NAD83(2011)
	UTM – Zone 18N
	NAVD88
	GEOID12A
	Meters

Northing	Easting	Elevation
4439610.343	489850.101	51.795

Operator	Kevin Chapman
Receiver Model	Trimble R-8, Model 3
Receiver S/N	5106461067
Antenna Height	2.000 Meters

Date (MM-DD-YYYY)	04/23/2015
RMSE Hz	0.013
RMSE Z	0.013
GPS Method	Keynet VRS

PHOTOS:





Point ID	CP21
Project No.	26236
Project Name	DELAWARE VALLEY LiDAR
State	New Jersey
County	Mercer
Quad	Pennington

	Aerial Target
X	LiDAR Ground Control
	LiDAR QC Point
	New Control
	Photo ID
	Published Control

Coordinate System
NAD83(2011)
UTM – Zone 18N
NAVD88
GEOID12A
Meters

Northing	Easting	Elevation
4461326.146	510943.784	13.987

Operator	Kevin Chapman
Receiver Model	Trimble R-8, Model 3
Receiver S/N	5106461067
Antenna Height	2.000 Meters

Date (MM-DD-YYYY)	06/14/2015
RMSE Hz	0.015
RMSE Z	0.016
GPS Method	Keynet VRS

PHOTOS:







Point ID	CP21
Project No.	26236
Project Name	DELAWARE VALLEY LiDAR
State	New Jersey
County	Mercer
Quad	Pennington

	Aerial Target
X	LiDAR Ground Control
	LiDAR QC Point
	New Control
	Photo ID
	Published Control

Coordinate System	
NAD83(2011)	
UTM – Zone 18N	
NAVD88	
GEOID12A	
Meters	

Northing	Easting	Elevation
4461326.146	510943.784	13.987

Operator	Kevin Chapman
Receiver Model	Trimble R-8, Model 3
Receiver S/N	5106461067
Antenna Height	2.000 Meters

Date (MM-DD-YYYY)	06/14/2015
RMSE Hz	0.015
RMSE Z	0.016
GPS Method	Keynet VRS

PHOTOS:





Point ID	CP22
Project No.	26236
Project Name	DELAWARE VALLEY LiDAR
State	New Jersey
County	Mercer
Quad	Hopewell

	Aerial Target
X	LiDAR Ground Control
	LiDAR QC Point
	New Control
	Photo ID
	Published Control

Coordinate System
NAD83(2011)
UTM – Zone 18N
NAVD88
GEOID12A
Meters

<b>Northing</b>	<b>Easting</b>	<b>Elevation</b>
4470732.766	520437.688	47.914

Operator	Kevin Chapman
Receiver Model	Trimble R-8, Model 3
Receiver S/N	5106461067
Antenna Height	2.000 Meters

Date (MM-DD-YYYY)	06/14/2015
RMSE Hz	0.014
RMSE Z	0.015
GPS Method	Keynet VRS

PHOTOS:





Point ID	CP23
Project No.	26236
Project Name	DELAWARE VALLEY LiDAR
State	Pennsylvania
County	Delaware
Quad	Marcus Hook

Aerial Target	
X	LiDAR Ground Control
	LiDAR QC Point
	New Control
	Photo ID
	Published Control

Coordinate System	
	NAD83(2011)
	UTM – Zone 18N
	NAVD88
	GEOID12A
	Meters

Northing	Easting	Elevation
4408028.765	464189.997	8.719

Operator	Kevin Chapman
Receiver Model	Trimble R-8, Model 3
Receiver S/N	5106461067
Antenna Height	2.000 Meters

Date (MM-DD-YYYY)	05/07/2015
RMSE Hz	0.007
RMSE Z	0.009
GPS Method	Keynet VRS

PHOTOS:





Point ID	C30
Project No.	26236
Project Name	DELAWARE VALLEY LiDAR
State	New Jersey
County	Burlington
Quad	New Egypt

Aerial Target	
X	LiDAR Ground Control
	LiDAR QC Point
	New Control
	Photo ID
	Published Control

Coordinate System	
	NAD83(2011)
	UTM – Zone 18N
	NAVD88
	GEOID12A
	Meters

Northing	Easting	Elevation
4433696.916	536981.134	25.016

Operator	Kevin Chapman
Receiver Model	Trimble R-8, Model 3
Receiver S/N	5106461067
Antenna Height	2.000 Meters

Date (MM-DD-YYYY)	06/13/2015
RMSE Hz	0.014
RMSE Z	0.013
GPS Method	Keynet VRS

PHOTOS:





Point ID	CP31
Project No.	26236
Project Name	DELAWARE VALLEY LiDAR
State	New Jersey
County	Burlington
Quad	Whiting

	Aerial Target
X	LiDAR Ground Control
	LiDAR QC Point
	New Control
	Photo ID
	Published Control

Coordinate System	
NAD83(2011)	
UTM – Zone 18N	
NAVD88	
GEOID12A	
Meters	

Northing	Easting	Elevation
4422271.669	543710.144	27.948

Operator	Kevin Chapman
Receiver Model	Trimble R-8, Model 3
Receiver S/N	5106461067
Antenna Height	2.000 Meters

Date (MM-DD-YYYY)	06/12/2015
RMSE Hz	N/A
RMSE Z	N/A
GPS Method	Keynet VRS

PHOTOS:





Point ID	C32
Project No.	26236
Project Name	DELAWARE VALLEY LiDAR
State	New Jersey
County	Burlington
Quad	Browns Mills

	Aerial Target
X	LiDAR Ground Control
	LiDAR QC Point
	New Control
	Photo ID
	Published Control

Coordinate System
NAD83(2011)
UTM – Zone 18N
NAVD88
GEOID12A
Meters

<b>Northing</b>	<b>Easting</b>	<b>Elevation</b>
4415104.073	535503.242	28.164

Operator	Kevin Chapman
Receiver Model	Trimble R-8, Model 3
Receiver S/N	5106461067
Antenna Height	2.000 Meters

Date (MM-DD-YYYY)	06/12/2015
RMSE Hz	N/A
RMSE Z	N/A
GPS Method	Keynet VRS

PHOTOS:





Point ID	C39
Project No.	26236
Project Name	DELAWARE VALLEY LiDAR
State	New Jersey
County	Burlington
Quad	Woodmansie

	Aerial Target
X	LiDAR Ground Control
	LiDAR QC Point
	New Control
	Photo ID
	Published Control

Coordinate System
NAD83(2011)
UTM – Zone 18N
NAVD88
GEOID12A
Meters

Northing	Easting	Elevation
4409673.574	545754.089	36.250

Operator	Kevin Chapman
Receiver Model	Trimble R-8, Model 3
Receiver S/N	5106461067
Antenna Height	2.000 Meters

Date (MM-DD-YYYY)	06/12/2015
RMSE Hz	N/A
RMSE Z	N/A
GPS Method	Keynet VRS

PHOTOS:





Point ID	CP56
Project No.	26236
Project Name	DVRPC/NJ LIDAR
State	NEW JERSEY
County	GLOUCESTER
Quad	MEDFORD LAKES

Aerial Target	
LiDAR Ground Control	
X LiDAR QC Point	
New Control	
Photo ID	
Published Control	

Coordinate System	NAD83(2011)
	UTM – Zone 18N
	NAVD88
	GEOID12A
	Meters

Northing	Easting	Elevation
4402732.969	514450.992	30.399

Operator	STEVE MILLER
Receiver Model	Trimble R-8, Model 3
Receiver S/N	5108461884
Antenna Height	2.000 Meters

Date (MM-DD-YYYY)	06/04/2015
RMSE Hz	0.006
RMSE Z	0.007
GPS Method	RTK/STATIC

PHOTOS:







Point ID	CP24
Project No.	26236
Project Name	DVRPC/NJ LIDAR
State	NEW JERSEY
County	BURLINGTON
Quad	NEW GRETN

Aerial Target	
LiDAR Ground Control	
X LiDAR QC Point	
New Control	
Photo ID	
Published Control	

Coordinate System	NAD83(2011)
	UTM – Zone 18N
	NAVD88
	GEOID12A
	Meters

<b>Northing</b>	<b>Easting</b>	<b>Elevation</b>
4380951.771	547150.025	0.853

Operator	STEVE MILLER
Receiver Model	Trimble R-8, Model 3
Receiver S/N	5133470976
Antenna Height	2.000 Meters

Date (MM-DD-YYYY)	06/12/2015
RMSE Hz	0.008
RMSE Z	0.010
GPS Method	RTK/STATIC

PHOTOS:





Point ID	CP25
Project No.	26236
Project Name	DVRPC/NJ LIDAR
State	NEW JERSEY
County	BURLINGTON
Quad	COLUMBUS

Aerial Target	
LiDAR Ground Control	
X LiDAR QC Point	
New Control	
Photo ID	
Published Control	

Coordinate System	NAD83(2011)
	UTM – Zone 18N
	NAVD88
	GEOID12A
	Meters

<b>Northing</b>	<b>Easting</b>	<b>Elevation</b>
4435951.596	524718.155	21.991

Operator	STEVE MILLER
Receiver Model	Trimble R-8, Model 3
Receiver S/N	5108461884
Antenna Height	2.000 Meters

Date (MM-DD-YYYY)	06/06/2015
RMSE Hz	0.007
RMSE Z	0.007
GPS Method	RTK/STATIC

PHOTOS:





Point ID	CP26
Project No.	26236
Project Name	DVRPC/NJ LIDAR
State	NEW JERSEY
County	BURLINGTON
Quad	MOORESTOWN

	Aerial Target
	LiDAR Ground Control
X	LiDAR QC Point
	New Control
	Photo ID
	Published Control

Coordinate System
NAD83(2011)
UTM – Zone 18N
NAVD88
GEOID12A
Meters

Northing	Easting	Elevation
4424856.061	508744.959	12.342

Operator	STEVE MILLER
Receiver Model	Trimble R-8, Model 3
Receiver S/N	5108461884
Antenna Height	2.000 Meters

Date (MM-DD-YYYY)	06/05/2015
RMSE Hz	0.006
RMSE Z	0.007
GPS Method	RTK/STATIC

PHOTOS:





Point ID	CP27
Project No.	26236
Project Name	DVRPC/NJ LIDAR
State	NEW JERSEY
County	GLOUCESTER
Quad	RUNNEMEDE

Aerial Target	
LiDAR Ground Control	
X LiDAR QC Point	
New Control	
Photo ID	
Published Control	

Coordinate System	NAD83(2011)
	UTM – Zone 18N
	NAVD88
	GEOID12A
	Meters

Northing	Easting	Elevation
4401391.789	486309.408	46.251

Operator	STEVE MILLER
Receiver Model	Trimble R-8, Model 3
Receiver S/N	5108461884
Antenna Height	2.000 Meters

Date (MM-DD-YYYY)	06/03/2015
RMSE Hz	0.007
RMSE Z	0.008
GPS Method	STATIC/RTK

PHOTOS:





Point ID	CP28
Project No.	26236
Project Name	DVRPC/NJ LIDAR
State	NEW JERSEY
County	GLOUCESTER
Quad	PITTMAN WEST

Aerial Target	
LiDAR Ground Control	
X LiDAR QC Point	
New Control	
Photo ID	
Published Control	

Coordinate System	NAD83(2011)
	UTM – Zone 18N
	NAVD88
	GEOID12A
	Meters

<b>Northing</b>	<b>Easting</b>	<b>Elevation</b>
4392160.513	482573.781	41.409

Operator	STEVE MILLER
Receiver Model	Trimble R-8, Model 3
Receiver S/N	51084611884
Antenna Height	2.000 Meters

Date (MM-DD-YYYY)	06/03/2015
RMSE Hz	0.007
RMSE Z	0.008
GPS Method	RTK/STATIC

PHOTOS:





Point ID	CP29
Project No.	26236
Project Name	DVRPC/NJ LIDAR
State	NEW JERSEY
County	CAMDEN
Quad	CLEMENTON

	Aerial Target
	LiDAR Ground Control
X	LiDAR QC Point
	New Control
	Photo ID
	Published Control

Coordinate System
NAD83(2011)
UTM – Zone 18N
NAVD88
GEOID12A
Meters

Northing	Easting	Elevation
4402389.986	508557.423	50.649

Operator	STEVE MILLER
Receiver Model	Trimble R-8, Model 3
Receiver S/N	5108461884
Antenna Height	2.000 Meters

Date (MM-DD-YYYY)	06/05/2015
RMSE Hz	0.007
RMSE Z	0.007
GPS Method	RTK/STATIC

PHOTOS:





Point ID	CP33
Project No.	26236
Project Name	DVRPC/NJ LIDAR
State	NEW JERSEY
County	BURLINGTON
Quad	INDIAN MILLS

	Aerial Target
	LiDAR Ground Control
X	LiDAR QC Point
	New Control
	Photo ID
	Published Control

Coordinate System	NAD83(2011)
	UTM – Zone 18N
	NAVD88
	GEOID12A
	Meters

Northing	Easting	Elevation
4404320.072	529108.807	17.008

Operator	STEVE MILLER
Receiver Model	Trimble R-8, Model 3
Receiver S/N	5133470976
Antenna Height	2.000 Meters

Date (MM-DD-YYYY)	06/14/2015
RMSE Hz	0.007
RMSE Z	0.008
GPS Method	RTK/STATIC

PHOTOS:





Point ID	CP34
Project No.	26236
Project Name	DVRPC/NJ LIDAR
State	NEW JERSEY
County	BURLINGTON
Quad	MEDFORD LAKES

Aerial Target	
LiDAR Ground Control	
X LiDAR QC Point	
New Control	
Photo ID	
Published Control	

Coordinate System	NAD83(2011)
	UTM – Zone 18N
	NAVD88
	GEOID12A
	Meters

Northing	Easting	Elevation
4404633.120	521124.203	25.121

Operator	STEVE MILLER
Receiver Model	Trimble R-8, Model 3
Receiver S/N	5133470976
Antenna Height	2.000 Meters

Date (MM-DD-YYYY)	06/14/2015
RMSE Hz	0.007
RMSE Z	0.008
GPS Method	RTK/STATIC

PHOTOS:







Point ID	CP35
Project No.	26236
Project Name	DVRPC/NJ LIDAR
State	NEW JERSEY
County	GLOUCESTER
Quad	HAMMONTOWN

	Aerial Target
	LiDAR Ground Control
X	LiDAR QC Point
	New Control
	Photo ID
	Published Control

Coordinate System	NAD83(2011)
	UTM – Zone 18N
	NAVD88
	GEOID12A
	Meters

Northing	Easting	Elevation
4393488.954	513192.681	30.833

Operator	STEVE MILLER
Receiver Model	Trimble R-8, Model 3
Receiver S/N	5108461884
Antenna Height	2.000 Meters

Date (MM-DD-YYYY)	06/04/2015
RMSE Hz	0.007
RMSE Z	0.008
GPS Method	RTK/STATIC

PHOTOS:





Point ID	CP36
Project No.	26236
Project Name	DVRPC/NJ LIDAR
State	NEW JERSEY
County	GLOUCESTER
Quad	NEWFIELD

	Aerial Target
	LiDAR Ground Control
X	LiDAR QC Point
	New Control
	Photo ID
	Published Control

Coordinate System
NAD83(2011)
UTM – Zone 18N
NAVD88
GEOID12A
Meters

Northing	Easting	Elevation
4385354.158	492983.935	32.668

Operator	STEVE MILLER
Receiver Model	Trimble R-8, Model 3
Receiver S/N	5108461884
Antenna Height	2.000 Meters

Date (MM-DD-YYYY)	06/03/2015
RMSE Hz	0.007
RMSE Z	0.008
GPS Method	RTK/STATIC

PHOTOS:





Point ID	CP37
Project No.	26236
Project Name	DVRPC/NJ LIDAR
State	NEW JERSEY
County	GLOUCESTER
Quad	BUENA

	Aerial Target
	LiDAR Ground Control
X	LiDAR QC Point
	New Control
	Photo ID
	Published Control

Coordinate System	
NAD83(2011)	
UTM – Zone 18N	
NAVD88	
GEOID12A	
Meters	

Northing	Easting	Elevation
4378228.291	500184.559	36.395

Operator	STEVE MILLER
Receiver Model	Trimble R-8, Model 3
Receiver S/N	5108461884
Antenna Height	2.000 Meters

Date (MM-DD-YYYY)	06/04/2015
RMSE Hz	0.006
RMSE Z	0.008
GPS Method	RTK/STATIC

PHOTOS:





Point ID	CP38
Project No.	26236
Project Name	DVRPC/NJ LIDAR
State	NEW JERSEY
County	BURLINGTON
Quad	JCHATSWORTH

Aerial Target	
LiDAR Ground Control	
X LiDAR QC Point	
New Control	
Photo ID	
Published Control	

Coordinate System	NAD83(2011)
	UTM – Zone 18N
	NAVD88
	GEOID12A
	Meters

Northing	Easting	Elevation
4400182.275	535539.817	17.709

Operator	STEVE MILLER
Receiver Model	Trimble R-8, Model 3
Receiver S/N	5133470976
Antenna Height	2.000 Meters

Date (MM-DD-YYYY)	06/13/2015
RMSE Hz	0.011
RMSE Z	0.012
GPS Method	RTK/STATIC

PHOTOS:





Point ID	CP40
Project No.	26236
Project Name	DVRPC/NJ LIDAR
State	NEW JERSEY
County	BURLINGTON
Quad	WOODMANSIE

	Aerial Target
	LiDAR Ground Control
X	LiDAR QC Point
	New Control
	Photo ID
	Published Control

Coordinate System
NAD83(2011)
UTM – Zone 18N
NAVD88
GEOID12A
Meters

Northing	Easting	Elevation
4401690.393	550604.308	29.746

Operator	STEVE MILLER
Receiver Model	Trimble R-8, Model 3
Receiver S/N	5133470976
Antenna Height	2.000 Meters

Date (MM-DD-YYYY)	06/13/2015
RMSE Hz	0.007
RMSE Z	0.010
GPS Method	RTK/STATIC

PHOTOS:





Point ID	CP41
Project No.	26236
Project Name	DVRPC/NJ LIDAR
State	NEW JERSEY
County	BURLINGTON
Quad	WOODMANSIE

	Aerial Target
	LiDAR Ground Control
X	LiDAR QC Point
	New Control
	Photo ID
	Published Control

Coordinate System	
NAD83(2011)	
UTM – Zone 18N	
NAVD88	
GEOID12A	
Meters	

Northing	Easting	Elevation
4394697.037	552295.838	40.830

Operator	STEVE MILLER
Receiver Model	Trimble R-8, Model 3
Receiver S/N	5108461884
Antenna Height	2.000 Meters

Date (MM-DD-YYYY)	06/13/2015
RMSE Hz	0.007
RMSE Z	0.009
GPS Method	RTK/STATIC

PHOTOS:





Point ID	CP42
Project No.	26236
Project Name	DVRPC/NJ LIDAR
State	NEW JERSEY
County	BURLINGTON
Quad	JENKINS

Aerial Target	
LiDAR Ground Control	
X LiDAR QC Point	
New Control	
Photo ID	
Published Control	

Coordinate System	
NAD83(2011)	
UTM – Zone 18N	
NAVD88	
GEOID12A	
Meters	

Northing	Easting	Elevation
4386164.427	533160.038	1.399

Operator	STEVE MILLER
Receiver Model	Trimble R-8, Model 3
Receiver S/N	5133470976
Antenna Height	2.000 Meters

Date (MM-DD-YYYY)	06/13/2015
RMSE Hz	0.010
RMSE Z	0.012
GPS Method	RTK/STATIC

PHOTOS:





Point ID	CP43
Project No.	26236
Project Name	DVRPC/NJ LIDAR
State	NEW JERSEY
County	BURLINGTON
Quad	NEW GRETN

Aerial Target	
LiDAR Ground Control	
X LiDAR QC Point	
New Control	
Photo ID	
Published Control	

Coordinate System	
NAD83(2011)	
UTM – Zone 18N	
NAVD88	
GEOID12A	
Meters	

Northing	Easting	Elevation
4385862.477	549516.693	7.245

Operator	STEVE MILLER
Receiver Model	Trimble R-8, Model 3
Receiver S/N	5108461884
Antenna Height	2.000 Meters

Date (MM-DD-YYYY)	06/12/2015
RMSE Hz	0.007
RMSE Z	0.012
GPS Method	RTK/STATIC

PHOTOS:







Point ID	CP46
Project No.	26236
Project Name	DELAWARE VALLEY
State	NEW JERSEY
County	GLOUCESTER
Quad	WOODSTOWN

	Aerial Target
	LiDAR Ground Control
X	LiDAR QC Point
	New Control
	Photo ID
	Published Control

Coordinate System
NAD83(2011)
UTM – Zone 18N
NAVD88
GEOID12A
Meters

Northing	Easting	Elevation
4396862.739	477927.472	33.984

Operator	STEVE MILLER
Receiver Model	Trimble R-8, Model 3
Receiver S/N	5133470976
Antenna Height	2.000 Meters

Date (MM-DD-YYYY)	06/03/2015
RMSE Hz	0.006
RMSE Z	0.008
GPS Method	RTK

PHOTOS:





Point ID	CP47
Project No.	26236
Project Name	DVRPC/NJ LIDAR
State	NEW JERSEY
County	GLOUCESTER
Quad	BRIDGEPORT

Aerial Target	
LiDAR Ground Control	
X LiDAR QC Point	
New Control	
Photo ID	
Published Control	

Coordinate System	NAD83(2011)
	UTM – Zone 18N
	NAVD88
	GEOID12A
	Meters

Northing	Easting	Elevation
4401984.706	468823.341	4.596

Operator	STEVE MILLER
Receiver Model	Trimble R-8, Model 3
Receiver S/N	5108461884
Antenna Height	2.000 Meters

Date (MM-DD-YYYY)	06/03/2015
RMSE Hz	0.006
RMSE Z	0.008
GPS Method	RTK/STATIC

PHOTOS:





Point ID	CP48
Project No.	26236
Project Name	DVRPC/NJ LIDAR
State	NEW JERSEY
County	GLOUCESTER
Quad	BRIDGEPORT

Aerial Target	
LiDAR Ground Control	
X LiDAR QC Point	
New Control	
Photo ID	
Published Control	

Coordinate System	NAD83(2011)
	UTM – Zone 18N
	NAVD88
	GEOID12A
	Meters

<b>Northing</b>	<b>Easting</b>	<b>Elevation</b>
4408298.295	475044.910	3.553

Operator	STEVE MILLER
Receiver Model	Trimble R-8, Model 3
Receiver S/N	5108461884
Antenna Height	2.000 Meters

Date (MM-DD-YYYY)	06/03/2015
RMSE Hz	0.007
RMSE Z	0.008
GPS Method	RTK/STATIC

PHOTOS:





Point ID	CP50
Project No.	26236
Project Name	DVRPC/NJ LIDAR
State	NEW JERSEY
County	GLOUCESTER
Quad	RUNNEMEDE

Aerial Target	
LiDAR Ground Control	
X LiDAR QC Point	
New Control	
Photo ID	
Published Control	

Coordinate System	
NAD83(2011)	
UTM – Zone 18N	
NAVD88	
GEOID12A	
Meters	

Northing	Easting	Elevation
4405925.259	489382.523	22.361

Operator	STEVE MILLER
Receiver Model	Trimble R-8, Model 3
Receiver S/N	5135472526
Antenna Height	2.000 Meters

Date (MM-DD-YYYY)	06/03/2015
RMSE Hz	0.007
RMSE Z	0.007
GPS Method	STATIC/RTK

PHOTOS:





Point ID	CP51
Project No.	26236
Project Name	DVRPC/NJ LIDAR
State	NEW JERSEY
County	GLOUCESTER
Quad	PITTMAN EAST

Aerial Target	
LiDAR Ground Control	
X LiDAR QC Point	
New Control	
Photo ID	
Published Control	

Coordinate System	NAD83(2011)
	UTM – Zone 18N
	NAVD88
	GEOID12A
	Meters

<b>Northing</b>	<b>Easting</b>	<b>Elevation</b>
4395705.132	493948.654	47.121

Operator	STEVE MILLER
Receiver Model	Trimble R-8, Model 3
Receiver S/N	5108461884
Antenna Height	2.000 Meters

Date (MM-DD-YYYY)	06/03/2015
RMSE Hz	0.007
RMSE Z	0.008
GPS Method	RTK/STATIC

PHOTOS:





Point ID	CP52
Project No.	26236
Project Name	DVRPC/NJ LIDAR
State	NEW JERSEY
County	GLOUCESTER
Quad	PITTMAN WEST

Aerial Target	
LiDAR Ground Control	
X LiDAR QC Point	
New Control	
Photo ID	
Published Control	

Coordinate System	NAD83(2011)
	UTM – Zone 18N
	NAVD88
	GEOID12A
	Meters

<b>Northing</b>	<b>Easting</b>	<b>Elevation</b>
4388571.676	488253.552	41.298

Operator	STEVE MILLER
Receiver Model	Trimble R-8, Model 3
Receiver S/N	51084611884
Antenna Height	2.000 Meters

Date (MM-DD-YYYY)	06/03/2015
RMSE Hz	0.007
RMSE Z	0.008
GPS Method	RTK/STATIC

PHOTOS:





Point ID	CP53
Project No.	26236
Project Name	DVRPC/NJ LIDAR
State	NEW JERSEY
County	GLOUCESTER
Quad	NEWFIELD

	Aerial Target
	LiDAR Ground Control
X	LiDAR QC Point
	New Control
	Photo ID
	Published Control

Coordinate System
NAD83(2011)
UTM – Zone 18N
NAVD88
GEOID12A
Meters

Northing	Easting	Elevation
4381123.053	495727.076	27.612

Operator	STEVE MILLER
Receiver Model	Trimble R-8, Model 3
Receiver S/N	5108461884
Antenna Height	2.000 Meters

Date (MM-DD-YYYY)	06/04/2015
RMSE Hz	0.006
RMSE Z	0.007
GPS Method	RTK/STATIC

PHOTOS:





Point ID	CP54
Project No.	26236
Project Name	DVRPC/NJ LIDAR
State	NEW JERSEY
County	GLOUCESTER
Quad	WILLIAMSTOWN

Aerial Target	
LiDAR Ground Control	
X LiDAR QC Point	
New Control	
Photo ID	
Published Control	

Coordinate System	
NAD83(2011)	
UTM – Zone 18N	
NAVD88	
GEOID12A	
Meters	

Northing	Easting	Elevation
4389490.677	501360.315	38.484

Operator	STEVE MILLER
Receiver Model	Trimble R-8, Model 3
Receiver S/N	5108461884
Antenna Height	2.000 Meters

Date (MM-DD-YYYY)	06/04/2015
RMSE Hz	0.006
RMSE Z	0.007
GPS Method	RTK/STATIC

PHOTOS:







Point ID	CP55
Project No.	26236
Project Name	DVRPC/NJ LIDAR
State	NEW JERSEY
County	GLOUCESTER
Quad	WILLIAMSTOWN

	Aerial Target
	LiDAR Ground Control
X	LiDAR QC Point
	New Control
	Photo ID
	Published Control

Coordinate System	NAD83(2011)
	UTM – Zone 18N
	NAVD88
	GEOID12A
	Meters

Northing	Easting	Elevation
4396120.773	506661.233	47.037

Operator	STEVE MILLER
Receiver Model	Trimble R-8, Model 3
Receiver S/N	5108461884
Antenna Height	2.000 Meters

Date (MM-DD-YYYY)	06/04/2015
RMSE Hz	0.006
RMSE Z	0.008
GPS Method	RTK/STATIC

PHOTOS:





Point ID	CP57
Project No.	26236
Project Name	DVRPC/NJ LIDAR
State	NEW JERSEY
County	CAMDEN
Quad	CAMDEN

Aerial Target	
LiDAR Ground Control	
LiDAR QC Point	
New Control	
X Photo ID	
Published Control	

Coordinate System	NAD83(2011)
	UTM – Zone 18N
	NAVD88
	GEOID12A
	Meters

Northing	Easting	Elevation
4419031.845	492292.670	3.785

Operator	STEVE MILLER
Receiver Model	Trimble R-8, Model 3
Receiver S/N	5108461884
Antenna Height	2.000 Meters

Date (MM-DD-YYYY)	06/05/2015
RMSE Hz	0.006
RMSE Z	0.007
GPS Method	RTK/STATIC

PHOTOS:





Point ID	CP58
Project No.	26236
Project Name	DVRPC/NJ LIDAR
State	NEW JERSEY
County	CAMDEN
Quad	RUNNEMEDE

Aerial Target	
LiDAR Ground Control	
X LiDAR QC Point	
New Control	
Photo ID	
Published Control	

Coordinate System	NAD83(2011)
	UTM – Zone 18N
	NAVD88
	GEOID12A
	Meters

Northing	Easting	Elevation
4406835.294	498659.825	20.525

Operator	STEVE MILLER
Receiver Model	Trimble R-8, Model 3
Receiver S/N	5108461884
Antenna Height	2.000 Meters

Date (MM-DD-YYYY)	06/05/2015
RMSE Hz	0.007
RMSE Z	0.008
GPS Method	RTK/STATIC

PHOTOS:





Point ID	CP59
Project No.	26236
Project Name	DVRPC/NJ LIDAR
State	NEW JERSEY
County	CAMDEN
Quad	RUNNEMEDE

Aerial Target	
LiDAR Ground Control	
X LiDAR QC Point	
New Control	
Photo ID	
Published Control	

Coordinate System	NAD83(2011)
	UTM – Zone 18N
	NAVD88
	GEOID12A
	Meters

Northing	Easting	Elevation
4400255.068	501435.928	44.318

Operator	STEVE MILLER
Receiver Model	Trimble R-8, Model 3
Receiver S/N	5108461884
Antenna Height	2.000 Meters

Date (MM-DD-YYYY)	06/05/2015
RMSE Hz	0.006
RMSE Z	0.007
GPS Method	RTK/STATIC

PHOTOS:





Point ID	CP60
Project No.	26236
Project Name	DVRPC/NJ LIDAR
State	NEW JERSEY
County	CAMDEN
Quad	CLEMENTON

	Aerial Target
	LiDAR Ground Control
X	LiDAR QC Point
	New Control
	Photo ID
	Published Control

Coordinate System	NAD83(2011)
	UTM – Zone 18N
	NAVD88
	GEOID12A
	Meters

Northing	Easting	Elevation
4412491.384	504458.737	45.324

Operator	STEVE MILLER
Receiver Model	Trimble R-8, Model 3
Receiver S/N	5108461884
Antenna Height	2.000 Meters

Date (MM-DD-YYYY)	06/05/2015
RMSE Hz	0.006
RMSE Z	0.007
GPS Method	RTK/STATIC

PHOTOS:





Point ID	CP61
Project No.	26236
Project Name	DVRPC/NJ LIDAR
State	NEW JERSEY
County	BURLINGTON
Quad	MOORESTOWN

Aerial Target	
LiDAR Ground Control	
X LiDAR QC Point	
New Control	
Photo ID	
Published Control	

Coordinate System	NAD83(2011)
	UTM – Zone 18N
	NAVD88
	GEOID12A
	Meters

Northing	Easting	Elevation
4419128.401	509447.896	21.062

Operator	STEVE MILLER
Receiver Model	Trimble R-8, Model 3
Receiver S/N	5108461884
Antenna Height	2.000 Meters

Date (MM-DD-YYYY)	06/05/2015
RMSE Hz	0.006
RMSE Z	0.007
GPS Method	RTK/STATIC

PHOTOS:





Point ID	CP62
Project No.	26236
Project Name	DVRPC/NJ LIDAR
State	NEW JERSEY
County	CAMDEN
Quad	CAMDEN

Aerial Target	
LiDAR Ground Control	
X LiDAR QC Point	
New Control	
Photo ID	
Published Control	

Coordinate System	
NAD83(2011)	
UTM – Zone 18N	
NAVD88	
GEOID12A	
Meters	

Northing	Easting	Elevation
4425119.704	497012.581	15.108

Operator	STEVE MILLER
Receiver Model	Trimble R-8, Model 3
Receiver S/N	5108461884
Antenna Height	2.000 Meters

Date (MM-DD-YYYY)	06/06/2015
RMSE Hz	0.006
RMSE Z	0.007
GPS Method	RTK/STATIC

PHOTOS:





Point ID	CP63
Project No.	26236
Project Name	DVRPC/NJ LIDAR
State	NEW JERSEY
County	BURLINGTON
Quad	BEVERLY

	Aerial Target
	LiDAR Ground Control
X	LiDAR QC Point
	New Control
	Photo ID
	Published Control

Coordinate System	NAD83(2011)
	UTM – Zone 18N
	NAVD88
	GEOID12A
	Meters

Northing	Easting	Elevation
4431445.394	502552.149	4.904

Operator	STEVE MILLER
Receiver Model	Trimble R-8, Model 3
Receiver S/N	5108461884
Antenna Height	2.000 Meters

Date (MM-DD-YYYY)	06/06/2015
RMSE Hz	0.006
RMSE Z	0.008
GPS Method	RTK/STATIC

PHOTOS:







Point ID	CP64
Project No.	26236
Project Name	DVRPC/NJ LIDAR
State	NEW JERSEY
County	BURLINGTON
Quad	BEVERLY

Aerial Target	
LiDAR Ground Control	
X LiDAR QC Point	
New Control	
Photo ID	
Published Control	

Coordinate System	NAD83(2011)
	UTM – Zone 18N
	NAVD88
	GEOID12A
	Meters

Northing	Easting	Elevation
4435809.666	510714.719	1.871

Operator	STEVE MILLER
Receiver Model	Trimble R-8, Model 3
Receiver S/N	5108461884
Antenna Height	2.000 Meters

Date (MM-DD-YYYY)	06/06/2015
RMSE Hz	0.007
RMSE Z	0.008
GPS Method	RTK/STATIC

PHOTOS:





Point ID	CP65
Project No.	26236
Project Name	DVRPC/NJ LIDAR
State	NEW JERSEY
County	BURLINGTON
Quad	COLUMBUS

Aerial Target	
LiDAR Ground Control	
X LiDAR QC Point	
New Control	
Photo ID	
Published Control	

Coordinate System	NAD83(2011)
	UTM – Zone 18N
	NAVD88
	GEOID12A
	Meters

Northing	Easting	Elevation
4431921.989	526383.158	22.003

Operator	STEVE MILLER
Receiver Model	Trimble R-8, Model 3
Receiver S/N	5108461884
Antenna Height	2.000 Meters

Date (MM-DD-YYYY)	06/06/2015
RMSE Hz	0.006
RMSE Z	0.007
GPS Method	RTK/STATIC

PHOTOS:





Point ID	CP66
Project No.	26236
Project Name	DVRPC/NJ LIDAR
State	NEW JERSEY
County	BURLINGTON
Quad	PEMBERTON

Aerial Target	
LiDAR Ground Control	
X LiDAR QC Point	
New Control	
Photo ID	
Published Control	

Coordinate System	NAD83(2011)
	UTM – Zone 18N
	NAVD88
	GEOID12A
	Meters

<b>Northing</b>	<b>Easting</b>	<b>Elevation</b>
4428091.484	521472.954	22.246

Operator	STEVE MILLER
Receiver Model	Trimble R-8, Model 3
Receiver S/N	5133470976
Antenna Height	2.000 Meters

Date (MM-DD-YYYY)	06/06/2015
RMSE Hz	0.007
RMSE Z	0.008
GPS Method	RTK/STATIC

PHOTOS:





Point ID	CP67
Project No.	26236
Project Name	DVRPC/NJ LIDAR
State	NEW JERSEY
County	BURLINGTON
Quad	MT. HOLLY

Aerial Target	
LiDAR Ground Control	
X LiDAR QC Point	
New Control	
Photo ID	
Published Control	

Coordinate System	NAD83(2011)
	UTM – Zone 18N
	NAVD88
	GEOID12A
	Meters

Northing	Easting	Elevation
4422816.044	516118.465	14.233

Operator	STEVE MILLER
Receiver Model	Trimble R-8, Model 3
Receiver S/N	5108461884
Antenna Height	2.000 Meters

Date (MM-DD-YYYY)	06/06/2015
RMSE Hz	0.007
RMSE Z	0.007
GPS Method	RTK/STATIC

PHOTOS:





Point ID	CP68
Project No.	26236
Project Name	DVRPC/NJ LIDAR
State	NEW JERSEY
County	BURLINGTON
Quad	PEMBERTON

Aerial Target	
LiDAR Ground Control	
X LiDAR QC Point	
New Control	
Photo ID	
Published Control	

Coordinate System	NAD83(2011)
	UTM – Zone 18N
	NAVD88
	GEOID12A
	Meters

Northing	Easting	Elevation
4420677.102	521622.086	12.566

Operator	STEVE MILLER
Receiver Model	Trimble R-8, Model 3
Receiver S/N	5133470976
Antenna Height	2.000 Meters

Date (MM-DD-YYYY)	06/06/2015
RMSE Hz	0.007
RMSE Z	0.008
GPS Method	RTK/STATIC

PHOTOS:





Point ID	CP69
Project No.	26236
Project Name	DVRPC/NJ LIDAR
State	NEW JERSEY
County	BURLINGTON
Quad	NEW GREтна

Aerial Target	
LiDAR Ground Control	
X LiDAR QC Point	
New Control	
Photo ID	
Published Control	

Coordinate System	NAD83(2011)
	UTM – Zone 18N
	NAVD88
	GEOID12A
	Meters

Northing	Easting	Elevation
4398233.644	487223.130	41.340

Operator	STEVE MILLER
Receiver Model	Trimble R-8, Model 3
Receiver S/N	5133470976
Antenna Height	2.000 Meters

Date (MM-DD-YYYY)	06/12/2015
RMSE Hz	0.006
RMSE Z	0.007
GPS Method	RTK/STATIC

PHOTOS:





Point ID	CP70
Project No.	26236
Project Name	DVRPC/NJ LIDAR
State	NEW JERSEY
County	BURLINGTON
Quad	NEW GREтна

Aerial Target	
LiDAR Ground Control	
X LiDAR QC Point	
New Control	
Photo ID	
Published Control	

Coordinate System	NAD83(2011)
	UTM – Zone 18N
	NAVD88
	GEOID12A
	Meters

Northing	Easting	Elevation
4420677.102	521622.086	12.566

Operator	STEVE MILLER
Receiver Model	Trimble R-8, Model 3
Receiver S/N	5133470976
Antenna Height	2.000 Meters

Date (MM-DD-YYYY)	06/12/2015
RMSE Hz	0.007
RMSE Z	0.010
GPS Method	RTK/STATIC

PHOTOS:





Point ID	CP71
Project No.	26236
Project Name	DVRPC/NJ LIDAR
State	NEW JERSEY
County	BURLINGTON
Quad	GREEN BANK

Aerial Target	
LiDAR Ground Control	
X LiDAR QC Point	
New Control	
Photo ID	
Published Control	

Coordinate System	NAD83(2011)
	UTM – Zone 18N
	NAVD88
	GEOID12A
	Meters

Northing	Easting	Elevation
4382791.887	538730.107	1.657

Operator	STEVE MILLER
Receiver Model	Trimble R-8, Model 3
Receiver S/N	5133470976
Antenna Height	2.000 Meters

Date (MM-DD-YYYY)	06/12/2015
RMSE Hz	0.007
RMSE Z	0.009
GPS Method	RTK/STATIC

PHOTOS:







Point ID	CP72
Project No.	26236
Project Name	DVRPC/NJ LIDAR
State	NEW JERSEY
County	BURLINGTON
Quad	GREEN BANK

Aerial Target	
LiDAR Ground Control	
X LiDAR QC Point	
New Control	
Photo ID	
Published Control	

Coordinate System	NAD83(2011)
	UTM – Zone 18N
	NAVD88
	GEOID12A
	Meters

Northing	Easting	Elevation
4385228.903	536167.920	8.176

Operator	STEVE MILLER
Receiver Model	Trimble R-8, Model 3
Receiver S/N	5133470976
Antenna Height	2.000 Meters

Date (MM-DD-YYYY)	06/13/2015
RMSE Hz	0.007
RMSE Z	0.010
GPS Method	RTK/STATIC

PHOTOS:





Point ID	CP73
Project No.	26236
Project Name	DVRPC/NJ LIDAR
State	NEW JERSEY
County	BURLINGTON
Quad	JENKINS

Aerial Target	
LiDAR Ground Control	
X LiDAR QC Point	
New Control	
Photo ID	
Published Control	

Coordinate System	NAD83(2011)
	UTM – Zone 18N
	NAVD88
	GEOID12A
	Meters

Northing	Easting	Elevation
4392906.551	540012.263	13.331

Operator	STEVE MILLER
Receiver Model	Trimble R-8, Model 3
Receiver S/N	5133470976
Antenna Height	2.000 Meters

Date (MM-DD-YYYY)	06/13/2015
RMSE Hz	0.009
RMSE Z	0.010
GPS Method	RTK/STATIC

PHOTOS:





Point ID	CP74
Project No.	26236
Project Name	DVRPC/NJ LIDAR
State	NEW JERSEY
County	BURLINGTON
Quad	JENKINS

Aerial Target	
LiDAR Ground Control	
X LiDAR QC Point	
New Control	
Photo ID	
Published Control	

Coordinate System	NAD83(2011)
	UTM – Zone 18N
	NAVD88
	GEOID12A
	Meters

Northing	Easting	Elevation
4399345.399	540309.995	17.119

Operator	STEVE MILLER
Receiver Model	Trimble R-8, Model 3
Receiver S/N	5135472526
Antenna Height	2.000 Meters

Date (MM-DD-YYYY)	06/13/2015
RMSE Hz	0.010
RMSE Z	0.010
GPS Method	RTK/STATIC

PHOTOS:





Point ID	CP75
Project No.	26236
Project Name	DVRPC/NJ LIDAR
State	NEW JERSEY
County	BURLINGTON
Quad	CHATSWORTH

Aerial Target	
LiDAR Ground Control	
X LiDAR QC Point	
New Control	
Photo ID	
Published Control	

Coordinate System	NAD83(2011)
	UTM – Zone 18N
	NAVD88
	GEOID12A
	Meters

<b>Northing</b>	<b>Easting</b>	<b>Elevation</b>
4407406.408	539636.263	29.698

Operator	STEVE MILLER
Receiver Model	Trimble R-8, Model 3
Receiver S/N	5133470976
Antenna Height	2.000 Meters

Date (MM-DD-YYYY)	06/13/2015
RMSE Hz	0.009
RMSE Z	0.010
GPS Method	RTK/STATIC

PHOTOS:





Point ID	CP76
Project No.	26236
Project Name	DVRPC/NJ LIDAR
State	NEW JERSEY
County	BURLINGTON
Quad	MEDFORD LAKES

Aerial Target	
LiDAR Ground Control	
X LiDAR QC Point	
New Control	
Photo ID	
Published Control	

Coordinate System	NAD83(2011)
	UTM – Zone 18N
	NAVD88
	GEOID12A
	Meters

Northing	Easting	Elevation
4407646.191	519985.518	32.676

Operator	STEVE MILLER
Receiver Model	Trimble R-8, Model 3
Receiver S/N	5133470976
Antenna Height	2.000 Meters

Date (MM-DD-YYYY)	06/14/2015
RMSE Hz	0.007
RMSE Z	0.008
GPS Method	RTK/STATIC

PHOTOS:





Point ID	CP77
Project No.	26236
Project Name	DVRPC/NJ LIDAR
State	NEW JERSEY
County	BURLINGTON
Quad	INDIAN MILLS

Aerial Target	
LiDAR Ground Control	
X LiDAR QC Point	
New Control	
Photo ID	
Published Control	

Coordinate System	NAD83(2011)
	UTM – Zone 18N
	NAVD88
	GEOID12A
	Meters

Northing	Easting	Elevation
4413139.146	529675.188	29.901

Operator	STEVE MILLER
Receiver Model	Trimble R-8, Model 3
Receiver S/N	5133470976
Antenna Height	2.000 Meters

Date (MM-DD-YYYY)	06/14/2015
RMSE Hz	0.007
RMSE Z	0.008
GPS Method	RTK/STATIC

PHOTOS:





Point ID	CP78
Project No.	26236
Project Name	DVRPC/NJ LIDAR
State	NEW JERSEY
County	BURLINGTON
Quad	TRENTON EAST

	Aerial Target
	LiDAR Ground Control
X	LiDAR QC Point
	New Control
	Photo ID
	Published Control

Coordinate System
NAD83(2011)
UTM – Zone 18N
NAVD88
GEOID12A
Meters

Northing	Easting	Elevation
4449264.183	523881.137	19.092

Operator	STEVE MILLER
Receiver Model	Trimble R-8, Model 3
Receiver S/N	5108461884
Antenna Height	2.000 Meters

Date (MM-DD-YYYY)	06/15/2015
RMSE Hz	0.012
RMSE Z	0.016
GPS Method	RTK/STATIC

PHOTOS:





Point ID	CP79
Project No.	26236
Project Name	DVRPC/NJ LIDAR
State	NEW JERSEY
County	BURLINGTON
Quad	ALLENTOWN

Aerial Target	
LiDAR Ground Control	
X LiDAR QC Point	
New Control	
Photo ID	
Published Control	

Coordinate System	
NAD83(2011)	
UTM – Zone 18N	
NAVD88	
GEOID12A	
Meters	

<b>Northing</b>	<b>Easting</b>	<b>Elevation</b>
4454891.902	536200.682	31.376

Operator	STEVE MILLER
Receiver Model	Trimble R-8, Model 3
Receiver S/N	5108461884
Antenna Height	2.000 Meters

Date (MM-DD-YYYY)	06/15/2015
RMSE Hz	0.008
RMSE Z	0.009
GPS Method	RTK/STATIC

PHOTOS:







## **NON-VEGETATION POINT DATA SHEETS**



## **BARE EARTH POINT DATA SHEETS**



Point ID	BE2
Project No.	26236
Project Name	DELAWARE VALLEY LiDAR
State	Pennsylvania
County	Bucks
Quad	Bedminster

Aerial Target	
LiDAR Ground Control	
X LiDAR QC Point	
New Control	
Photo ID	
Published Control	

Coordinate System	
NAD83(2011)	
UTM – Zone 18N	
NAVD88	
GEOID12A	
Meters	

<b>Northing</b>	<b>Easting</b>	<b>Elevation</b>
4483119.170	484489.501	159.320

Operator	Kevin Chapman
Receiver Model	Trimble R-8, Model 3
Receiver S/N	5106461067
Antenna Height	2.000 Meters

Date (MM-DD-YYYY)	04/15/2015
RMSE Hz	0.021
RMSE Z	0.024
GPS Method	Keynet VRS

PHOTOS:





Point ID	BE9
Project No.	26236
Project Name	DELAWARE VALLEY LiDAR
State	Pennsylvania
County	Montgomery
Quad	Phoenixville

	Aerial Target
	LiDAR Ground Control
X	LiDAR QC Point
	New Control
	Photo ID
	Published Control

Coordinate System	NAD83(2011)
	UTM – Zone 18N
	NAVD88
	GEOID12A
	Meters

Northing	Easting	Elevation
4447078.997	456848.786	76.790

Operator	Kevin Chapman
Receiver Model	Trimble R-8, Model 3
Receiver S/N	5106461067
Antenna Height	2.000 Meters

Date (MM-DD-YYYY)	04/17/2015
RMSE Hz	N/A
RMSE Z	N/A
GPS Method	Keynet VRS

PHOTOS:





Point ID	BE50
Project No.	26236
Project Name	DVRPC/NJ LIDAR
State	NEW JERSEY
County	GLOUCESTER
Quad	RUNNEMEDE

Aerial Target	
LiDAR Ground Control	
X LiDAR QC Point	
New Control	
Photo ID	
Published Control	

Coordinate System	
NAD83(2011)	
UTM – Zone 18N	
NAVD88	
GEOID12A	
Meters	

Northing	Easting	Elevation
4401431.248	486090.221	43.534

Operator	STEVE MILLER
Receiver Model	Trimble R-8, Model 3
Receiver S/N	5135472526
Antenna Height	2.000 Meters

Date (MM-DD-YYYY)	06/03/2015
RMSE Hz	0.014
RMSE Z	0.021
GPS Method	RTK

PHOTOS:





Point ID	BE55
Project No.	26236
Project Name	DVRPC/NJ LIDAR
State	NEW JERSEY
County	GLOUCESTER
Quad	BUENA

	Aerial Target
	LiDAR Ground Control
X	LiDAR QC Point
	New Control
	Photo ID
	Published Control

Coordinate System	
NAD83(2011)	
UTM – Zone 18N	
NAVD88	
GEOID12A	
Meters	

Northing	Easting	Elevation
4378310.508	500114.285	36.013

Operator	STEVE MILLER
Receiver Model	Trimble R-8, Model 3
Receiver S/N	5135472526
Antenna Height	2.000 Meters

Date (MM-DD-YYYY)	06/04/2015
RMSE Hz	0.013
RMSE Z	0.015
GPS Method	RTK

PHOTOS:





Point ID	BE58
Project No.	26236
Project Name	DVRPC/NJ LIDAR
State	NEW JERSEY
County	GLOUCESTER
Quad	MEDFORD LAKES

Aerial Target	
LiDAR Ground Control	
X LiDAR QC Point	
New Control	
Photo ID	
Published Control	

Coordinate System	NAD83(2011)
	UTM – Zone 18N
	NAVD88
	GEOID12A
	Meters

Northing	Easting	Elevation
4402955.310	514904.757	29.966

Operator	STEVE MILLER
Receiver Model	Trimble R-8, Model 3
Receiver S/N	5135472526
Antenna Height	2.000 Meters

Date (MM-DD-YYYY)	06/04/2015
RMSE Hz	0.013
RMSE Z	0.012
GPS Method	RTK

PHOTOS:





Point ID	BE62
Project No.	26236
Project Name	DVRPC/NJ LIDAR
State	NEW JERSEY
County	CAMDEN
Quad	CLEMENTON

Aerial Target	
LiDAR Ground Control	
X LiDAR QC Point	
New Control	
Photo ID	
Published Control	

Coordinate System	NAD83(2011)
	UTM – Zone 18N
	NAVD88
	GEOID12A
	Meters

Northing	Easting	Elevation
4412577.851	504486.140	44.269

Operator	STEVE MILLER
Receiver Model	Trimble R-8, Model 3
Receiver S/N	5135472526
Antenna Height	2.000 Meters

Date (MM-DD-YYYY)	06/05/2015
RMSE Hz	0.013
RMSE Z	0.015
GPS Method	RTK

PHOTOS:







Point ID	BE64
Project No.	26236
Project Name	DVRPC/NJ LIDAR
State	NEW JERSEY
County	BURLINGTON
Quad	BEVERLY

Aerial Target	
LiDAR Ground Control	
X LiDAR QC Point	
New Control	
Photo ID	
Published Control	

Coordinate System	NAD83(2011)
	UTM – Zone 18N
	NAVD88
	GEOID12A
	Meters

Northing	Easting	Elevation
4435705.050	510200.853	3.366

Operator	STEVE MILLER
Receiver Model	Trimble R-8, Model 3
Receiver S/N	5135472526
Antenna Height	2.000 Meters

Date (MM-DD-YYYY)	06/06/2015
RMSE Hz	0.014
RMSE Z	0.015
GPS Method	RTK

PHOTOS:





Point ID	BE67
Project No.	26236
Project Name	DELAWARE VALLEY LiDAR
State	New Jersey
County	Burlington
Quad	Browns Mills

Aerial Target	
LiDAR Ground Control	
X LiDAR QC Point	
New Control	
Photo ID	
Published Control	

Coordinate System	NAD83(2011)
	UTM – Zone 18N
	NAVD88
	GEOID12A
	Meters

<b>Northing</b>	<b>Easting</b>	<b>Elevation</b>
4422418.173	533612.339	16.614

Operator	Kevin Chapman
Receiver Model	Trimble R-8, Model 3
Receiver S/N	5106461067
Antenna Height	2.000 Meters

Date (MM-DD-YYYY)	06/12/2015
RMSE Hz	0.013
RMSE Z	0.012
GPS Method	Keynet VRS

PHOTOS:





Point ID	BE71
Project No.	26236
Project Name	DVRPC/NJ LIDAR
State	NEW JERSEY
County	BURLINGTON
Quad	JENKINS

Aerial Target	
LiDAR Ground Control	
X LiDAR QC Point	
New Control	
Photo ID	
Published Control	

Coordinate System	NAD83(2011)
	UTM – Zone 18N
	NAVD88
	GEOID12A
	Meters

Northing	Easting	Elevation
4392826.765	539990.878	12.581

Operator	STEVE MILLER
Receiver Model	Trimble R-8, Model 3
Receiver S/N	5135472526
Antenna Height	2.000 Meters

Date (MM-DD-YYYY)	06/13/2015
RMSE Hz	0.012
RMSE Z	0.013
GPS Method	RTK

PHOTOS:





Point ID	BE82
Project No.	26236
Project Name	DELAWARE VALLEY LiDAR
State	New Jersey
County	Burlington
Quad	Whiting

	Aerial Target
	LiDAR Ground Control
X	LiDAR QC Point
	New Control
	Photo ID
	Published Control

Coordinate System
NAD83(2011)
UTM – Zone 18N
NAVD88
GEOID12A
Meters

Northing	Easting	Elevation
4415848.142	543288.429	38.017

Operator	Kevin Chapman
Receiver Model	Trimble R-8, Model 3
Receiver S/N	5106461067
Antenna Height	2.000 Meters

Date (MM-DD-YYYY)	06/12/2015
RMSE Hz	0.014
RMSE Z	0.014
GPS Method	Keynet VRS

PHOTOS:





## URBAN AREA POINT DATA SHEETS



Point ID	UA1
Project No.	26236
Project Name	DELAWARE VALLEY LiDAR
State	Pennsylvania
County	Bucks
Quad	Riegelsville

Aerial Target	
LiDAR Ground Control	
X LiDAR QC Point	
New Control	
Photo ID	
Published Control	

Coordinate System	NAD83(2011)
	UTM – Zone 18N
	NAVD88
	GEOID12A
	Meters

<b>Northing</b>	<b>Easting</b>	<b>Elevation</b>
4488869.518	488312.933	184.228

Operator	Kevin Chapman
Receiver Model	Trimble R-8, Model 3
Receiver S/N	5106461067
Antenna Height	2.000 Meters

Date (MM-DD-YYYY)	04/15/2015
RMSE Hz	N/A
RMSE Z	N/A
GPS Method	Keynet VRS

PHOTOS:





Point ID	UA3
Project No.	26236
Project Name	DELAWARE VALLEY LiDAR
State	Pennsylvania
County	Bucks
Quad	Quakertown

	Aerial Target
	LiDAR Ground Control
X	LiDAR QC Point
	New Control
	Photo ID
	Published Control

Coordinate System
NAD83(2011)
UTM – Zone 18N
NAVD88
GEOID12A
Meters

Northing	Easting	Elevation
4479760.044	476838.716	153.667

Operator	Kevin Chapman
Receiver Model	Trimble R-8, Model 3
Receiver S/N	5106461067
Antenna Height	2.000 Meters

Date (MM-DD-YYYY)	04/15/2015
RMSE Hz	N/A
RMSE Z	N/A
GPS Method	Keynet VRS

PHOTOS:





Point ID	UA4
Project No.	26236
Project Name	DELAWARE VALLEY LiDAR
State	Pennsylvania
County	Bucks
Quad	Quakertown

	Aerial Target
	LiDAR Ground Control
X	LiDAR QC Point
	New Control
X	Photo ID
	Published Control

Coordinate System
NAD83(2011)
UTM – Zone 18N
NAVD88
GEOID12A
Meters

Northing	Easting	Elevation
4474313.503	470887.945	159.618

Operator	Kevin Chapman
Receiver Model	Trimble R-8, Model 3
Receiver S/N	5106461067
Antenna Height	2.000 Meters

Date (MM-DD-YYYY)	04/15/2015
RMSE Hz	N/A
RMSE Z	N/A
GPS Method	Keynet VRS

PHOTOS:







Point ID	UA5
Project No.	26236
Project Name	DELAWARE VALLEY LiDAR
State	Pennsylvania
County	Bucks
Quad	Milford Square

Aerial Target	
LiDAR Ground Control	
X LiDAR QC Point	
New Control	
Photo ID	
Published Control	

Coordinate System	NAD83(2011)
	UTM – Zone 18N
	NAVD88
	GEOID12A
	Meters

<b>Northing</b>	<b>Easting</b>	<b>Elevation</b>
4470616.220	465192.747	164.770

Operator	Kevin Chapman
Receiver Model	Trimble R-8, Model 3
Receiver S/N	5106461067
Antenna Height	2.000 Meters

Date (MM-DD-YYYY)	04/18/2015
RMSE Hz	N/A
RMSE Z	N/A
GPS Method	Keynet VRS

PHOTOS:





Point ID	UA6
Project No.	26236
Project Name	DELAWARE VALLEY LiDAR
State	Pennsylvania
County	Montgomery
Quad	Perkiomenville

Aerial Target	
LiDAR Ground Control	
X LiDAR QC Point	
New Control	
Photo ID	
Published Control	

Coordinate System	NAD83(2011)
	UTM – Zone 18N
	NAVD88
	GEOID12A
	Meters

Northing	Easting	Elevation
4467121.945	459090.865	95.900

Operator	Kevin Chapman
Receiver Model	Trimble R-8, Model 3
Receiver S/N	5106461067
Antenna Height	2.000 Meters

Date (MM-DD-YYYY)	04/18/2015
RMSE Hz	0.019
RMSE Z	0.019
GPS Method	Keynet VRS

PHOTOS:





Point ID	UA7
Project No.	26236
Project Name	DELAWARE VALLEY LiDAR
State	Pennsylvania
County	Montgomery
Quad	Sassamansville

	Aerial Target
	LiDAR Ground Control
X	LiDAR QC Point
	New Control
X	Photo ID
	Published Control

Coordinate System	NAD83(2011)
	UTM – Zone 18N
	NAVD88
	GEOID12A
	Meters

Northing	Easting	Elevation
4460116.815	452354.114	85.964

Operator	Kevin Chapman
Receiver Model	Trimble R-8, Model 3
Receiver S/N	5106461067
Antenna Height	2.000 Meters

Date (MM-DD-YYYY)	04/18/2015
RMSE Hz	N/A
RMSE Z	N/A
GPS Method	Keynet VRS

PHOTOS:





Point ID	UA8
Project No.	26236
Project Name	DELAWARE VALLEY LiDAR
State	Pennsylvania
County	Montgomery
Quad	Phoenixville

Aerial Target	
LiDAR Ground Control	
X LiDAR QC Point	
New Control	
Photo ID	
Published Control	

Coordinate System	NAD83(2011)
	UTM – Zone 18N
	NAVD88
	GEOID12A
	Meters

Northing	Easting	Elevation
4454400.971	448348.459	46.114

Operator	Kevin Chapman
Receiver Model	Trimble R-8, Model 3
Receiver S/N	5106461067
Antenna Height	2.000 Meters

Date (MM-DD-YYYY)	04/17/2015
RMSE Hz	0.020
RMSE Z	0.020
GPS Method	Keynet VRS

PHOTOS:





Point ID	UA11
Project No.	26236
Project Name	DELAWARE VALLEY LiDAR
State	Pennsylvania
County	Montgomery
Quad	Perkiomenville

	Aerial Target
	LiDAR Ground Control
X	LiDAR QC Point
	New Control
X	Photo ID
	Published Control

Coordinate System	
NAD83(2011)	
UTM – Zone 18N	
NAVD88	
GEOID12A	
Meters	

Northing	Easting	Elevation
4460575.453	465279.032	79.962

Operator	Kevin Chapman
Receiver Model	Trimble R-8, Model 3
Receiver S/N	5106461067
Antenna Height	2.000 Meters

Date (MM-DD-YYYY)	04/18/2015
RMSE Hz	N/A
RMSE Z	N/A
GPS Method	Keynet VRS

PHOTOS:





Point ID	UA12
Project No.	26236
Project Name	DELAWARE VALLEY LiDAR
State	Pennsylvania
County	Montgomery
Quad	Lansdale

	Aerial Target
	LiDAR Ground Control
X	LiDAR QC Point
	New Control
X	Photo ID
	Published Control

Coordinate System
NAD83(2011)
UTM – Zone 18N
NAVD88
GEOID12A
Meters

Northing	Easting	Elevation
4460575.453	465279.032	79.962

Operator	Kevin Chapman
Receiver Model	Trimble R-8, Model 3
Receiver S/N	5106461067
Antenna Height	2.000 Meters

Date (MM-DD-YYYY)	04/15/2015
RMSE Hz	N/A
RMSE Z	N/A
GPS Method	Keynet VRS

PHOTOS:





Point ID	UA13
Project No.	26236
Project Name	DELAWARE VALLEY LiDAR
State	Pennsylvania
County	Bucks
Quad	Telford

Aerial Target	
LiDAR Ground Control	
X LiDAR QC Point	
New Control	
Photo ID	
Published Control	

Coordinate System	NAD83(2011)
	UTM – Zone 18N
	NAVD88
	GEOID12A
	Meters

Northing	Easting	Elevation
4463274.049	476097.162	189.288

Operator	Kevin Chapman
Receiver Model	Trimble R-8, Model 3
Receiver S/N	5106461067
Antenna Height	2.000 Meters

Date (MM-DD-YYYY)	04/15/2015
RMSE Hz	N/A
RMSE Z	N/A
GPS Method	Keynet VRS

PHOTOS:





Point ID	UA14
Project No.	26236
Project Name	DELAWARE VALLEY LiDAR
State	Pennsylvania
County	Bucks
Quad	Doylestown

	Aerial Target
	LiDAR Ground Control
X	LiDAR QC Point
	New Control
	Photo ID
	Published Control

Coordinate System
NAD83(2011)
UTM – Zone 18N
NAVD88
GEOID12A
Meters

Northing	Easting	Elevation
4468436.400	482299.129	174.635

Operator	Kevin Chapman
Receiver Model	Trimble R-8, Model 3
Receiver S/N	5106461067
Antenna Height	2.000 Meters

Date (MM-DD-YYYY)	04/24/2015
RMSE Hz	0.013
RMSE Z	0.014
GPS Method	Keynet VRS

PHOTOS:







Point ID	UA15
Project No.	26236
Project Name	DELAWARE VALLEY LiDAR
State	Pennsylvania
County	Bucks
Quad	Doylestown

Aerial Target	
LiDAR Ground Control	
X LiDAR QC Point	
New Control	
Photo ID	
Published Control	

Coordinate System	NAD83(2011)
	UTM – Zone 18N
	NAVD88
	GEOID12A
	Meters

Northing	Easting	Elevation
4467814.773	488598.764	133.268

Operator	Kevin Chapman
Receiver Model	Trimble R-8, Model 3
Receiver S/N	5106461067
Antenna Height	2.000 Meters

Date (MM-DD-YYYY)	04/24/2015
RMSE Hz	0.012
RMSE Z	0.014
GPS Method	Keynet VRS

PHOTOS:





Point ID	UA16
Project No.	26236
Project Name	DELAWARE VALLEY LiDAR
State	Pennsylvania
County	Bucks
Quad	Bedminster

Aerial Target	
LiDAR Ground Control	
X LiDAR QC Point	
New Control	
Photo ID	
Published Control	

Coordinate System	NAD83(2011)
	UTM – Zone 18N
	NAVD88
	GEOID12A
	Meters

Northing	Easting	Elevation
4467814.773	488598.764	133.268

Operator	Kevin Chapman
Receiver Model	Trimble R-8, Model 3
Receiver S/N	5106461067
Antenna Height	2.000 Meters

Date (MM-DD-YYYY)	04/24/2015
RMSE Hz	0.015
RMSE Z	0.017
GPS Method	Keynet VRS

PHOTOS:





Point ID	UA17
Project No.	26236
Project Name	DELAWARE VALLEY LiDAR
State	Pennsylvania
County	Bucks
Quad	Lumberville

Aerial Target	
LiDAR Ground Control	
X LiDAR QC Point	
New Control	
Photo ID	
Published Control	

Coordinate System	NAD83(2011)
	UTM – Zone 18N
	NAVD88
	GEOID12A
	Meters

Northing	Easting	Elevation
4467814.773	488598.764	133.268

Operator	Kevin Chapman
Receiver Model	Trimble R-8, Model 3
Receiver S/N	5106461067
Antenna Height	2.000 Meters

Date (MM-DD-YYYY)	04/24/2015
RMSE Hz	0.015
RMSE Z	0.017
GPS Method	Keynet VRS

PHOTOS:





Point ID	UA18
Project No.	26236
Project Name	DELAWARE VALLEY LiDAR
State	Pennsylvania
County	Bucks
Quad	Buckingham

	Aerial Target
	LiDAR Ground Control
X	LiDAR QC Point
	New Control
X	Photo ID
	Published Control

Coordinate System	NAD83(2011)
	UTM – Zone 18N
	NAVD88
	GEOID12A
	Meters

Northing	Easting	Elevation
4469115.376	496042.754	115.389

Operator	Kevin Chapman
Receiver Model	Trimble R-8, Model 3
Receiver S/N	5106461067
Antenna Height	2.000 Meters

Date (MM-DD-YYYY)	04/24/2015
RMSE Hz	0.015
RMSE Z	0.016
GPS Method	Keynet VRS

PHOTOS:





Point ID	UA19
Project No.	26236
Project Name	DELAWARE VALLEY LiDAR
State	Pennsylvania
County	Mercer
Quad	Buckingham

Aerial Target	
LiDAR Ground Control	
X LiDAR QC Point	
New Control	
Photo ID	
Published Control	

Coordinate System	NAD83(2011)
	UTM – Zone 18N
	NAVD88
	GEOID12A
	Meters

Northing	Easting	Elevation
4465221.968	498778.987	73.352

Operator	Kevin Chapman
Receiver Model	Trimble R-8, Model 3
Receiver S/N	5106461067
Antenna Height	2.000 Meters

Date (MM-DD-YYYY)	04/14/2015
RMSE Hz	N/A
RMSE Z	N/A
GPS Method	Keynet VRS

PHOTOS:





Point ID	UA20
Project No.	26236
Project Name	DELAWARE VALLEY LiDAR
State	Pennsylvania
County	Mercer
Quad	Buckingham

Aerial Target	
LiDAR Ground Control	
X LiDAR QC Point	
New Control	
Photo ID	
Published Control	

Coordinate System	NAD83(2011)
	UTM – Zone 18N
	NAVD88
	GEOID12A
	Meters

Northing	Easting	Elevation
4460654.382	493806.692	92.756

Operator	Kevin Chapman
Receiver Model	Trimble R-8, Model 3
Receiver S/N	5106461067
Antenna Height	2.000 Meters

Date (MM-DD-YYYY)	04/14/2015
RMSE Hz	N/A
RMSE Z	N/A
GPS Method	Keynet VRS

PHOTOS:





Point ID	UA21
Project No.	26236
Project Name	DELAWARE VALLEY LiDAR
State	Pennsylvania
County	Bucks
Quad	Ambler

	Aerial Target
	LiDAR Ground Control
X	LiDAR QC Point
	New Control
X	Photo ID
	Published Control

Coordinate System
NAD83(2011)
UTM – Zone 18N
NAVD88
GEOID12A
Meters

Northing	Easting	Elevation
4460654.382	493806.692	92.756

Operator	Kevin Chapman
Receiver Model	Trimble R-8, Model 3
Receiver S/N	5106461067
Antenna Height	2.000 Meters

Date (MM-DD-YYYY)	04/23/2015
RMSE Hz	0.014
RMSE Z	0.014
GPS Method	Keynet VRS

PHOTOS:





Point ID	UA22
Project No.	26236
Project Name	DELAWARE VALLEY LiDAR
State	Pennsylvania
County	Montgomery
Quad	Ambler

Aerial Target	
LiDAR Ground Control	
X LiDAR QC Point	
New Control	
Photo ID	
Published Control	

Coordinate System	NAD83(2011)
	UTM – Zone 18N
	NAVD88
	GEOID12A
	Meters

<b>Northing</b>	<b>Easting</b>	<b>Elevation</b>
4448792.662	480563.805	97.973

Operator	Kevin Chapman
Receiver Model	Trimble R-8, Model 3
Receiver S/N	5106461067
Antenna Height	2.000 Meters

Date (MM-DD-YYYY)	04/23/2015
RMSE Hz	0.014
RMSE Z	0.014
GPS Method	Keynet VRS

PHOTOS:







Point ID	UA23
Project No.	26236
Project Name	DELAWARE VALLEY LiDAR
State	Pennsylvania
County	Montgomery
Quad	Lansdale

Aerial Target	
LiDAR Ground Control	
X LiDAR QC Point	
New Control	
Photo ID	
Published Control	

Coordinate System	NAD83(2011)
	UTM – Zone 18N
	NAVD88
	GEOID12A
	Meters

Northing	Easting	Elevation
4443988.473	472236.874	66.375

Operator	Kevin Chapman
Receiver Model	Trimble R-8, Model 3
Receiver S/N	5106461067
Antenna Height	2.000 Meters

Date (MM-DD-YYYY)	04/15/2015
RMSE Hz	N/A
RMSE Z	N/A
GPS Method	Keynet VRS

PHOTOS:





Point ID	UA24
Project No.	26236
Project Name	DELAWARE VALLEY LiDAR
State	Pennsylvania
County	Montgomery
Quad	Norristown

	Aerial Target
	LiDAR Ground Control
X	LiDAR QC Point
	New Control
X	Photo ID
	Published Control

Coordinate System	
NAD83(2011)	
UTM – Zone 18N	
NAVD88	
GEOID12A	
Meters	

<b>Northing</b>	<b>Easting</b>	<b>Elevation</b>
4438894.829	468636.543	54.157

Operator	Kevin Chapman
Receiver Model	Trimble R-8, Model 3
Receiver S/N	5106461067
Antenna Height	2.000 Meters

Date (MM-DD-YYYY)	04/17/2015
RMSE Hz	N/A
RMSE Z	N/A
GPS Method	Keynet VRS

PHOTOS:





Point ID	UA25
Project No.	26236
Project Name	DELAWARE VALLEY LiDAR
State	Pennsylvania
County	Delaware
Quad	Marcus Hook

	Aerial Target
	LiDAR Ground Control
X	LiDAR QC Point
	New Control
X	Photo ID
	Published Control

Coordinate System
NAD83(2011)
UTM – Zone 18N
NAVD88
GEOID12A
Meters

Northing	Easting	Elevation
4411248.365	459802.504	68.170

Operator	Kevin Chapman
Receiver Model	Trimble R-8, Model 3
Receiver S/N	5106461067
Antenna Height	2.000 Meters

Date (MM-DD-YYYY)	05/07/2015
RMSE Hz	0.007
RMSE Z	0.009
GPS Method	Keynet VRS

PHOTOS:





Point ID	UA26
Project No.	26236
Project Name	DELAWARE VALLEY LiDAR
State	Pennsylvania
County	Delaware
Quad	Media

Aerial Target	
LiDAR Ground Control	
X LiDAR QC Point	
New Control	
Photo ID	
Published Control	

Coordinate System	NAD83(2011)
	UTM – Zone 18N
	NAVD88
	GEOID12A
	Meters

<b>Northing</b>	<b>Easting</b>	<b>Elevation</b>
4417480.712	464377.081	85.307

Operator	Kevin Chapman
Receiver Model	Trimble R-8, Model 3
Receiver S/N	5106461067
Antenna Height	2.000 Meters

Date (MM-DD-YYYY)	05/08/2015
RMSE Hz	0.007
RMSE Z	0.010
GPS Method	Keynet VRS

PHOTOS:





Point ID	UA27
Project No.	26236
Project Name	DELAWARE VALLEY LiDAR
State	Pennsylvania
County	Delaware
Quad	Lansdowne

	Aerial Target
	LiDAR Ground Control
X	LiDAR QC Point
	New Control
	Photo ID
	Published Control

Coordinate System
NAD83(2011)
UTM – Zone 18N
NAVD88
GEOID12A
Meters

Northing	Easting	Elevation
4414154.270	470429.007	23.589

Operator	Kevin Chapman
Receiver Model	Trimble R-8, Model 3
Receiver S/N	5106461067
Antenna Height	2.000 Meters

Date (MM-DD-YYYY)	05/07/2015
RMSE Hz	0.007
RMSE Z	0.008
GPS Method	Keynet VRS

PHOTOS:





Point ID	UA28
Project No.	26236
Project Name	DELAWARE VALLEY LiDAR
State	Pennsylvania
County	Philadelphia
Quad	Philadelphia

Aerial Target	
LiDAR Ground Control	
X LiDAR QC Point	
New Control	
Photo ID	
Published Control	

Coordinate System	NAD83(2011)
	UTM – Zone 18N
	NAVD88
	GEOID12A
	Meters

<b>Northing</b>	<b>Easting</b>	<b>Elevation</b>
4414154.270	470429.007	23.589

Operator	Kevin Chapman
Receiver Model	Trimble R-8, Model 3
Receiver S/N	5106461067
Antenna Height	2.000 Meters

Date (MM-DD-YYYY)	05/07/2015
RMSE Hz	0.007
RMSE Z	0.008
GPS Method	Keynet VRS

PHOTOS:





Point ID	UA29
Project No.	26236
Project Name	DELAWARE VALLEY LiDAR
State	Pennsylvania
County	Delaware
Quad	Lansdowne

Aerial Target	
LiDAR Ground Control	
X LiDAR QC Point	
New Control	
Photo ID	
Published Control	

Coordinate System	NAD83(2011)
	UTM – Zone 18N
	NAVD88
	GEOID12A
	Meters

Northing	Easting	Elevation
4422043.968	473787.559	71.443

Operator	Kevin Chapman
Receiver Model	Trimble R-8, Model 3
Receiver S/N	5106461067
Antenna Height	2.000 Meters

Date (MM-DD-YYYY)	05/07/2015
RMSE Hz	0.008
RMSE Z	0.010
GPS Method	Keynet VRS

PHOTOS:





Point ID	UA30
Project No.	26236
Project Name	DELAWARE VALLEY LiDAR
State	Pennsylvania
County	Delaware
Quad	Lansdowne

Aerial Target	
LiDAR Ground Control	
X LiDAR QC Point	
New Control	
Photo ID	
Published Control	

Coordinate System	NAD83(2011)
	UTM – Zone 18N
	NAVD88
	GEOID12A
	Meters

Northing	Easting	Elevation
4426364.285	468198.199	104.134

Operator	Kevin Chapman
Receiver Model	Trimble R-8, Model 3
Receiver S/N	5106461067
Antenna Height	2.000 Meters

Date (MM-DD-YYYY)	05/06/2015
RMSE Hz	0.008
RMSE Z	0.010
GPS Method	Keynet VRS

PHOTOS:







Point ID	UA31
Project No.	26236
Project Name	DELAWARE VALLEY LiDAR
State	Pennsylvania
County	Montgomery
Quad	Norristown

	Aerial Target
	LiDAR Ground Control
X	LiDAR QC Point
	New Control
	Photo ID
	Published Control

Coordinate System
NAD83(2011)
UTM – Zone 18N
NAVD88
GEOID12A
Meters

Northing	Easting	Elevation
4433016.458	477219.171	105.158

Operator	Kevin Chapman
Receiver Model	Trimble R-8, Model 3
Receiver S/N	5106461067
Antenna Height	2.000 Meters

Date (MM-DD-YYYY)	05/06/2015
RMSE Hz	0.010
RMSE Z	0.011
GPS Method	Keynet VRS

PHOTOS:





Point ID	UA32
Project No.	26236
Project Name	DELAWARE VALLEY LiDAR
State	Pennsylvania
County	Philadelphia
Quad	Germantown

Aerial Target	
LiDAR Ground Control	
X LiDAR QC Point	
New Control	
Photo ID	
Published Control	

Coordinate System	NAD83(2011)
	UTM – Zone 18N
	NAVD88
	GEOID12A
	Meters

Northing	Easting	Elevation
4428546.166	482724.549	32.220

Operator	Kevin Chapman
Receiver Model	Trimble R-8, Model 3
Receiver S/N	5106461067
Antenna Height	2.000 Meters

Date (MM-DD-YYYY)	05/07/2015
RMSE Hz	0.009
RMSE Z	0.010
GPS Method	Keynet VRS

PHOTOS:





Point ID	UA33
Project No.	26236
Project Name	DELAWARE VALLEY LiDAR
State	Pennsylvania
County	Philadelphia
Quad	Philadelphia

	Aerial Target
	LiDAR Ground Control
X	LiDAR QC Point
	New Control
	Photo ID
	Published Control

Coordinate System
NAD83(2011)
UTM – Zone 18N
NAVD88
GEOID12A
Meters

Northing	Easting	Elevation
4425270.856	487266.892	19.017

Operator	Kevin Chapman
Receiver Model	Trimble R-8, Model 3
Receiver S/N	5106461067
Antenna Height	2.000 Meters

Date (MM-DD-YYYY)	04/26/2015
RMSE Hz	0.014
RMSE Z	0.013
GPS Method	Keynet VRS

PHOTOS:





Point ID	UA34
Project No.	26236
Project Name	DELAWARE VALLEY LiDAR
State	Pennsylvania
County	Philadelphia
Quad	Frankford

Aerial Target	
LiDAR Ground Control	
X LiDAR QC Point	
New Control	
Photo ID	
Published Control	

Coordinate System	NAD83(2011)
	UTM – Zone 18N
	NAVD88
	GEOID12A
	Meters

<b>Northing</b>	<b>Easting</b>	<b>Elevation</b>
4432828.341	494441.779	33.287

Operator	Kevin Chapman
Receiver Model	Trimble R-8, Model 3
Receiver S/N	5106461067
Antenna Height	2.000 Meters

Date (MM-DD-YYYY)	04/26/2015
RMSE Hz	0.014
RMSE Z	0.015
GPS Method	Keynet VRS

PHOTOS:





Point ID	UA35
Project No.	26236
Project Name	DELAWARE VALLEY LiDAR
State	Pennsylvania
County	Montgomery
Quad	Germantown

	Aerial Target
	LiDAR Ground Control
X	LiDAR QC Point
	New Control
X	Photo ID
	Published Control

Coordinate System
NAD83(2011)
UTM – Zone 18N
NAVD88
GEOID12A
Meters

Northing	Easting	Elevation
4437163.405	486177.186	109.915

Operator	Kevin Chapman
Receiver Model	Trimble R-8, Model 3
Receiver S/N	5106461067
Antenna Height	2.000 Meters

Date (MM-DD-YYYY)	04/23/2015
RMSE Hz	0.014
RMSE Z	0.014
GPS Method	Keynet VRS

PHOTOS:





Point ID	UA36
Project No.	26236
Project Name	DELAWARE VALLEY LiDAR
State	Pennsylvania
County	Montgomery
Quad	Frankford

Aerial Target	
LiDAR Ground Control	
X LiDAR QC Point	
New Control	
Photo ID	
Published Control	

Coordinate System	
NAD83(2011)	
UTM – Zone 18N	
NAVD88	
GEOID12A	
Meters	

<b>Northing</b>	<b>Easting</b>	<b>Elevation</b>
4440774.580	493287.031	35.898

Operator	Kevin Chapman
Receiver Model	Trimble R-8, Model 3
Receiver S/N	5106461067
Antenna Height	2.000 Meters

Date (MM-DD-YYYY)	04/23/2015
RMSE Hz	0.013
RMSE Z	0.013
GPS Method	Keynet VRS

PHOTOS:





Point ID	UA37
Project No.	26236
Project Name	DELAWARE VALLEY LiDAR
State	Pennsylvania
County	Bucks
Quad	Hatboro

	Aerial Target
	LiDAR Ground Control
X	LiDAR QC Point
	New Control
	Photo ID
	Published Control

Coordinate System
NAD83(2011)
UTM – Zone 18N
NAVD88
GEOID12A
Meters

Northing	Easting	Elevation
4446198.762	499552.741	31.245

Operator	Kevin Chapman
Receiver Model	Trimble R-8, Model 3
Receiver S/N	5106461067
Antenna Height	2.000 Meters

Date (MM-DD-YYYY)	04/26/2015
RMSE Hz	0.013
RMSE Z	0.012
GPS Method	Keynet VRS

PHOTOS:





Point ID	UA38
Project No.	26236
Project Name	DELAWARE VALLEY LiDAR
State	Pennsylvania
County	Philadelphia
Quad	Beverly

	Aerial Target
	LiDAR Ground Control
X	LiDAR QC Point
	New Control
X	Photo ID
	Published Control

Coordinate System
NAD83(2011)
UTM – Zone 18N
NAVD88
GEOID12A
Meters

Northing	Easting	Elevation
4440093.360	502310.668	34.782

Operator	Kevin Chapman
Receiver Model	Trimble R-8, Model 3
Receiver S/N	5106461067
Antenna Height	2.000 Meters

Date (MM-DD-YYYY)	04/26/2015
RMSE Hz	0.014
RMSE Z	0.014
GPS Method	Keynet VRS

PHOTOS:







Point ID	UA39
Project No.	26236
Project Name	DELAWARE VALLEY LiDAR
State	Pennsylvania
County	Bucks
Quad	Langhorne

	Aerial Target
	LiDAR Ground Control
X	LiDAR QC Point
	New Control
X	Photo ID
	Published Control

Coordinate System	NAD83(2011)
	UTM – Zone 18N
	NAVD88
	GEOID12A
	Meters

Northing	Easting	Elevation
4450838.039	504131.849	46.515

Operator	Kevin Chapman
Receiver Model	Trimble R-8, Model 3
Receiver S/N	5106461067
Antenna Height	2.000 Meters

Date (MM-DD-YYYY)	04/26/2015
RMSE Hz	0.014
RMSE Z	0.013
GPS Method	Keynet VRS

PHOTOS:





Point ID	UA40
Project No.	26236
Project Name	DELAWARE VALLEY LiDAR
State	Pennsylvania
County	Bucks
Quad	Lambertville

	Aerial Target
	LiDAR Ground Control
X	LiDAR QC Point
	New Control
X	Photo ID
	Published Control

Coordinate System	NAD83(2011)
	UTM – Zone 18N
	NAVD88
	GEOID12A
	Meters

Northing	Easting	Elevation
4463539.006	506214.730	24.258

Operator	Kevin Chapman
Receiver Model	Trimble R-8, Model 3
Receiver S/N	5106461067
Antenna Height	2.000 Meters

Date (MM-DD-YYYY)	04/24/2015
RMSE Hz	0.014
RMSE Z	0.017
GPS Method	Keynet VRS

PHOTOS:





Point ID	UA41
Project No.	26236
Project Name	DELAWARE VALLEY LiDAR
State	Pennsylvania
County	Bucks
Quad	Pennington

	Aerial Target
	LiDAR Ground Control
X	LiDAR QC Point
	New Control
X	Photo ID
	Published Control

Coordinate System	NAD83(2011)
	UTM – Zone 18N
	NAVD88
	GEOID12A
	Meters

Northing	Easting	Elevation
4455551.738	512549.154	25.012

Operator	Kevin Chapman
Receiver Model	Trimble R-8, Model 3
Receiver S/N	5106461067
Antenna Height	2.000 Meters

Date (MM-DD-YYYY)	04/24/2015
RMSE Hz	0.014
RMSE Z	0.017
GPS Method	Keynet VRS

PHOTOS:





Point ID	UA42
Project No.	26236
Project Name	DELAWARE VALLEY LiDAR
State	New Jersey
County	Mercer
Quad	Pennington

Aerial Target	
LiDAR Ground Control	
X LiDAR QC Point	
New Control	
Photo ID	
Published Control	

Coordinate System	NAD83(2011)
	UTM – Zone 18N
	NAVD88
	GEOID12A
	Meters

<b>Northing</b>	<b>Easting</b>	<b>Elevation</b>
4459633.232	518008.585	55.454

Operator	Kevin Chapman
Receiver Model	Trimble R-8, Model 3
Receiver S/N	5106461067
Antenna Height	2.000 Meters

Date (MM-DD-YYYY)	06/14/2015
RMSE Hz	0.014
RMSE Z	0.013
GPS Method	Keynet VRS

PHOTOS:





Point ID	UA43
Project No.	26236
Project Name	DELAWARE VALLEY LiDAR
State	New Jersey
County	Mercer
Quad	Princeton

	Aerial Target
	LiDAR Ground Control
X	LiDAR QC Point
	New Control
	Photo ID
	Published Control

Coordinate System
NAD83(2011)
UTM – Zone 18N
NAVD88
GEOID12A
Meters

Northing	Easting	Elevation
4468127.612	522524.958	74.600

Operator	Kevin Chapman
Receiver Model	Trimble R-8, Model 3
Receiver S/N	5106461067
Antenna Height	2.000 Meters

Date (MM-DD-YYYY)	06/14/2015
RMSE Hz	0.014
RMSE Z	0.013
GPS Method	Keynet VRS

PHOTOS:





Point ID	UA47
Project No.	26236
Project Name	DELAWARE VALLEY LiDAR
State	New Jersey
County	Mercer
Quad	Trenton West

Aerial Target	
LiDAR Ground Control	
X LiDAR QC Point	
New Control	
Photo ID	
Published Control	

Coordinate System	NAD83(2011)
	UTM – Zone 18N
	NAVD88
	GEOID12A
	Meters

<b>Northing</b>	<b>Easting</b>	<b>Elevation</b>
4452456.872	519400.142	19.107

Operator	Kevin Chapman
Receiver Model	Trimble R-8, Model 3
Receiver S/N	5106461067
Antenna Height	2.000 Meters

Date (MM-DD-YYYY)	06/14/2015
RMSE Hz	0.014
RMSE Z	0.015
GPS Method	Keynet VRS

PHOTOS:





Point ID	UA49
Project No.	26236
Project Name	DVRPC/NJ LIDAR
State	NEW JERSEY
County	BURLINGTON
Quad	BEVERLY

Aerial Target	
LiDAR Ground Control	
X LiDAR QC Point	
New Control	
Photo ID	
Published Control	

Coordinate System	NAD83(2011)
	UTM – Zone 18N
	NAVD88
	GEOID12A
	Meters

Northing	Easting	Elevation
4435957.282	511380.153	1.935

Operator	STEVE MILLER
Receiver Model	Trimble R-8, Model 3
Receiver S/N	5135472526
Antenna Height	2.000 Meters

Date (MM-DD-YYYY)	06/06/2015
RMSE Hz	0.014
RMSE Z	0.015
GPS Method	RTK

PHOTOS:





Point ID	UA50
Project No.	26236
Project Name	DVRPC/NJ LIDAR
State	NEW JERSEY
County	BURLINGTON
Quad	BEVERLY

Aerial Target	
LiDAR Ground Control	
X LiDAR QC Point	
New Control	
Photo ID	
Published Control	

Coordinate System	NAD83(2011)
	UTM – Zone 18N
	NAVD88
	GEOID12A
	Meters

<b>Northing</b>	<b>Easting</b>	<b>Elevation</b>
4431398.036	502459.931	4.815

Operator	STEVE MILLER
Receiver Model	Trimble R-8, Model 3
Receiver S/N	5135472526
Antenna Height	2.000 Meters

Date (MM-DD-YYYY)	06/06/2015
RMSE Hz	0.013
RMSE Z	0.014
GPS Method	RTK

PHOTOS:







Point ID	UA51
Project No.	26236
Project Name	DVRPC/NJ LIDAR
State	NEW JERSEY
County	CAMDEN
Quad	CAMDEN

	Aerial Target
	LiDAR Ground Control
X	LiDAR QC Point
	New Control
	Photo ID
	Published Control

Coordinate System
NAD83(2011)
UTM – Zone 18N
NAVD88
GEOID12A
Meters

<b>Northing</b>	<b>Easting</b>	<b>Elevation</b>
4425064.161	497037.822	15.155

Operator	STEVE MILLER
Receiver Model	Trimble R-8, Model 3
Receiver S/N	5135472526
Antenna Height	2.000 Meters

Date (MM-DD-YYYY)	06/06/2015
RMSE Hz	0.013
RMSE Z	0.012
GPS Method	RTK

PHOTOS:





Point ID	UA52
Project No.	26236
Project Name	DVRPC/NJ LIDAR
State	NEW JERSEY
County	CAMDEN
Quad	CAMDEN

Aerial Target	
LiDAR Ground Control	
X LiDAR QC Point	
New Control	
Photo ID	
Published Control	

Coordinate System	NAD83(2011)
	UTM – Zone 18N
	NAVD88
	GEOID12A
	Meters

Northing	Easting	Elevation
4419009.209	492040.067	4.054

Operator	STEVE MILLER
Receiver Model	Trimble R-8, Model 3
Receiver S/N	5135472526
Antenna Height	2.000 Meters

Date (MM-DD-YYYY)	06/05/2015
RMSE Hz	0.013
RMSE Z	0.012
GPS Method	RTK

PHOTOS:





Point ID	UA59
Project No.	26236
Project Name	DVRPC/NJ LIDAR
State	NEW JERSEY
County	CAMDEN
Quad	RUNNEMEDE

Aerial Target	
LiDAR Ground Control	
X LiDAR QC Point	
New Control	
Photo ID	
Published Control	

Coordinate System	NAD83(2011)
	UTM – Zone 18N
	NAVD88
	GEOID12A
	Meters

Northing	Easting	Elevation
4406889.702	498446.357	17.213

Operator	STEVE MILLER
Receiver Model	Trimble R-8, Model 3
Receiver S/N	5135472526
Antenna Height	2.000 Meters

Date (MM-DD-YYYY)	06/05/2015
RMSE Hz	0.014
RMSE Z	0.015
GPS Method	RTK

PHOTOS:





Point ID	UA60
Project No.	26236
Project Name	DVRPC/NJ LIDAR
State	NEW JERSEY
County	CAMDEN
Quad	CLEMENTON

Aerial Target	
LiDAR Ground Control	
X LiDAR QC Point	
New Control	
Photo ID	
Published Control	

Coordinate System	NAD83(2011)
	UTM – Zone 18N
	NAVD88
	GEOID12A
	Meters

Northing	Easting	Elevation
4413038.487	504591.126	32.952

Operator	STEVE MILLER
Receiver Model	Trimble R-8, Model 3
Receiver S/N	5135472526
Antenna Height	2.000 Meters

Date (MM-DD-YYYY)	06/05/2015
RMSE Hz	0.013
RMSE Z	0.015
GPS Method	RTK

PHOTOS:





Point ID	UA61
Project No.	26236
Project Name	DVRPC/NJ LIDAR
State	NEW JERSEY
County	BURLINGTON
Quad	MOORESTOWN

Aerial Target	
LiDAR Ground Control	
X LiDAR QC Point	
New Control	
Photo ID	
Published Control	

Coordinate System	NAD83(2011)
	UTM – Zone 18N
	NAVD88
	GEOID12A
	Meters

Northing	Easting	Elevation
4419064.015	509164.841	19.978

Operator	STEVE MILLER
Receiver Model	Trimble R-8, Model 3
Receiver S/N	5135472526
Antenna Height	2.000 Meters

Date (MM-DD-YYYY)	06/05/2015
RMSE Hz	0.013
RMSE Z	0.013
GPS Method	RTK

PHOTOS:





Point ID	UA62
Project No.	26236
Project Name	DVRPC/NJ LIDAR
State	NEW JERSEY
County	BURLINGTON
Quad	MT. HOLLY

	Aerial Target
	LiDAR Ground Control
X	LiDAR QC Point
	New Control
	Photo ID
	Published Control

Coordinate System
NAD83(2011)
UTM – Zone 18N
NAVD88
GEOID12A
Meters

Northing	Easting	Elevation
4423022.814	516285.815	13.671

Operator	STEVE MILLER
Receiver Model	Trimble R-8, Model 3
Receiver S/N	5135472526
Antenna Height	2.000 Meters

Date (MM-DD-YYYY)	06/06/2015
RMSE Hz	0.013
RMSE Z	0.014
GPS Method	RTK

PHOTOS:





Point ID	UA63
Project No.	26236
Project Name	DVRPC/NJ LIDAR
State	NEW JERSEY
County	BURLINGTON
Quad	PEMBERTON

Aerial Target	
LiDAR Ground Control	
X LiDAR QC Point	
New Control	
Photo ID	
Published Control	

Coordinate System	NAD83(2011)
	UTM – Zone 18N
	NAVD88
	GEOID12A
	Meters

Northing	Easting	Elevation
4427859.884	521484.938	21.148

Operator	STEVE MILLER
Receiver Model	Trimble R-8, Model 3
Receiver S/N	5135472526
Antenna Height	2.000 Meters

Date (MM-DD-YYYY)	06/06/2015
RMSE Hz	0.014
RMSE Z	0.017
GPS Method	RTK

PHOTOS:





Point ID	UA64
Project No.	26236
Project Name	DVRPC/NJ LIDAR
State	NEW JERSEY
County	BURLINGTON
Quad	COLUMBUS

Aerial Target	
LiDAR Ground Control	
X LiDAR QC Point	
New Control	
Photo ID	
Published Control	

Coordinate System	NAD83(2011)
	UTM – Zone 18N
	NAVD88
	GEOID12A
	Meters

<b>Northing</b>	<b>Easting</b>	<b>Elevation</b>
4431932.939	526069.751	22.324

Operator	STEVE MILLER
Receiver Model	Trimble R-8, Model 3
Receiver S/N	5135472526
Antenna Height	2.000 Meters

Date (MM-DD-YYYY)	06/06/2015
RMSE Hz	0.013
RMSE Z	0.013
GPS Method	RTK/STATIC

PHOTOS:







Point ID	UA65
Project No.	26236
Project Name	DELAWARE VALLEY LiDAR
State	New Jersey
County	Burlington
Quad	New Egypt

Aerial Target	
LiDAR Ground Control	
X LiDAR QC Point	
New Control	
Photo ID	
Published Control	

Coordinate System	NAD83(2011)
	UTM – Zone 18N
	NAVD88
	GEOID12A
	Meters

<b>Northing</b>	<b>Easting</b>	<b>Elevation</b>
4439978.937	532561.490	29.570

Operator	Kevin Chapman
Receiver Model	Trimble R-8, Model 3
Receiver S/N	5106461067
Antenna Height	2.000 Meters

Date (MM-DD-YYYY)	06/13/2015
RMSE Hz	0.012
RMSE Z	0.012
GPS Method	Keynet VRS

PHOTOS:





Point ID	UA66
Project No.	26236
Project Name	DELAWARE VALLEY LiDAR
State	New Jersey
County	Burlington
Quad	Browns Mills

	Aerial Target
	LiDAR Ground Control
X	LiDAR QC Point
	New Control
	Photo ID
	Published Control

Coordinate System
NAD83(2011)
UTM – Zone 18N
NAVD88
GEOID12A
Meters

Northing	Easting	Elevation
4426927.489	538769.439	29.896

Operator	Kevin Chapman
Receiver Model	Trimble R-8, Model 3
Receiver S/N	5106461067
Antenna Height	2.000 Meters

Date (MM-DD-YYYY)	06/13/2015
RMSE Hz	0.014
RMSE Z	0.014
GPS Method	Keynet VRS

PHOTOS:





Point ID	UA67
Project No.	26236
Project Name	DVRPC/NJ LIDAR
State	NEW JERSEY
County	BURLINGTON
Quad	NEW GRETNA

Aerial Target	
LiDAR Ground Control	
X LiDAR QC Point	
New Control	
Photo ID	
Published Control	

Coordinate System	
NAD83(2011)	
UTM – Zone 18N	
NAVD88	
GEOID12A	
Meters	

<b>Northing</b>	<b>Easting</b>	<b>Elevation</b>
4381108.524	546829.511	1.410

Operator	STEVE MILLER
Receiver Model	Trimble R-8, Model 3
Receiver S/N	5135472526
Antenna Height	2.000 Meters

Date (MM-DD-YYYY)	06/12/2015
RMSE Hz	0.012
RMSE Z	0.012
GPS Method	RTK

PHOTOS:





Point ID	UA68
Project No.	26236
Project Name	DVRPC/NJ LIDAR
State	NEW JERSEY
County	BURLINGTON
Quad	PEMBERTON

Aerial Target	
LiDAR Ground Control	
X LiDAR QC Point	
New Control	
Photo ID	
Published Control	

Coordinate System	
NAD83(2011)	
UTM – Zone 18N	
NAVD88	
GEOID12A	
Meters	

<b>Northing</b>	<b>Easting</b>	<b>Elevation</b>
4420493.569	521688.917	11.961

Operator	STEVE MILLER
Receiver Model	Trimble R-8, Model 3
Receiver S/N	5135472526
Antenna Height	2.000 Meters

Date (MM-DD-YYYY)	06/06/2015
RMSE Hz	0.014
RMSE Z	0.018
GPS Method	RTK

PHOTOS:





Point ID	UA70
Project No.	26236
Project Name	DVRPC/NJ LIDAR
State	NEW JERSEY
County	BURLINGTON
Quad	MEDFORD LAKES

Aerial Target	
LiDAR Ground Control	
X LiDAR QC Point	
New Control	
Photo ID	
Published Control	

Coordinate System	NAD83(2011)
	UTM – Zone 18N
	NAVD88
	GEOID12A
	Meters

Northing	Easting	Elevation
4407262.358	520357.107	30.842

Operator	STEVE MILLER
Receiver Model	Trimble R-8, Model 3
Receiver S/N	5135472526
Antenna Height	2.000 Meters

Date (MM-DD-YYYY)	06/14/2015
RMSE Hz	0.013
RMSE Z	0.013
GPS Method	RTK

PHOTOS:





Point ID	UA71
Project No.	26236
Project Name	DVRPC/NJ LIDAR
State	NEW JERSEY
County	GLOUCESTER
Quad	MEDFORD LAKES

Aerial Target	
LiDAR Ground Control	
LiDAR QC Point	
New Control	
X Photo ID	
Published Control	

Coordinate System	NAD83(2011)
	UTM – Zone 18N
	NAVD88
	GEOID12A
	Meters

Northing	Easting	Elevation
4402824.865	514904.447	31.038

Operator	STEVE MILLER
Receiver Model	Trimble R-8, Model 3
Receiver S/N	5135472526
Antenna Height	2.000 Meters

Date (MM-DD-YYYY)	06/04/2015
RMSE Hz	0.011
RMSE Z	0.012
GPS Method	RTK

PHOTOS:





Point ID	UA72
Project No.	26236
Project Name	DVRPC/NJ LIDAR
State	NEW JERSEY
County	GLOUCESTER
Quad	WILLIAMSTOWN

	Aerial Target
	LiDAR Ground Control
X	LiDAR QC Point
	New Control
	Photo ID
	Published Control

Coordinate System
NAD83(2011)
UTM – Zone 18N
NAVD88
GEOID12A
Meters

Northing	Easting	Elevation
4395840.403	507463.520	42.946

Operator	STEVE MILLER
Receiver Model	Trimble R-8, Model 3
Receiver S/N	5133470976
Antenna Height	2.000 Meters

Date (MM-DD-YYYY)	06/04/2015
RMSE Hz	0.007
RMSE Z	0.008
GPS Method	RTK/STATIC

PHOTOS:





Point ID	UA73
Project No.	26236
Project Name	DVRPC/NJ LIDAR
State	NEW JERSEY
County	CAMDEN
Quad	RUNNEMEDE

Aerial Target	
LiDAR Ground Control	
X LiDAR QC Point	
New Control	
Photo ID	
Published Control	

Coordinate System	
NAD83(2011)	
UTM – Zone 18N	
NAVD88	
GEOID12A	
Meters	

Northing	Easting	Elevation
4400289.607	501725.586	44.133

Operator	STEVE MILLER
Receiver Model	Trimble R-8, Model 3
Receiver S/N	5135472526
Antenna Height	2.000 Meters

Date (MM-DD-YYYY)	06/05/2015
RMSE Hz	0.013
RMSE Z	0.013
GPS Method	RTK

PHOTOS:







Point ID	UA75
Project No.	26236
Project Name	DVRPC/NJ LIDAR
State	NEW JERSEY
County	GLOUCESTER
Quad	WILLIAMSTOWN

Aerial Target	
LiDAR Ground Control	
X LiDAR QC Point	
New Control	
Photo ID	
Published Control	

Coordinate System	NAD83(2011)
	UTM – Zone 18N
	NAVD88
	GEOID12A
	Meters

Northing	Easting	Elevation
4389511.492	501077.997	39.864

Operator	STEVE MILLER
Receiver Model	Trimble R-8, Model 3
Receiver S/N	5135472526
Antenna Height	2.000 Meters

Date (MM-DD-YYYY)	06/04/2015
RMSE Hz	0.013
RMSE Z	0.013
GPS Method	RTK

PHOTOS:





Point ID	UA79
Project No.	26236
Project Name	DVRPC/NJ LIDAR
State	NEW JERSEY
County	BURLINGTON
Quad	JCHATSWORTH

Aerial Target	
LiDAR Ground Control	
X LiDAR QC Point	
New Control	
Photo ID	
Published Control	

Coordinate System	
NAD83(2011)	
UTM – Zone 18N	
NAVD88	
GEOID12A	
Meters	

Northing	Easting	Elevation
4400228.025	535540.196	17.273

Operator	STEVE MILLER
Receiver Model	Trimble R-8, Model 3
Receiver S/N	5135472526
Antenna Height	2.000 Meters

Date (MM-DD-YYYY)	06/13/2015
RMSE Hz	0.015
RMSE Z	0.015
GPS Method	RTK

PHOTOS:





Point ID	UA83
Project No.	26236
Project Name	DELAWARE VALLEY LiDAR
State	New Jersey
County	Burlington
Quad	Woodmansie

Aerial Target	
LiDAR Ground Control	
X LiDAR QC Point	
New Control	
Photo ID	
Published Control	

Coordinate System	
NAD83(2011)	
UTM – Zone 18N	
NAVD88	
GEOID12A	
Meters	

Northing	Easting	Elevation
4407721.364	549285.477	58.861

Operator	Kevin Chapman
Receiver Model	Trimble R-8, Model 3
Receiver S/N	5106461067
Antenna Height	2.000 Meters

Date (MM-DD-YYYY)	06/12/2015
RMSE Hz	0.008
RMSE Z	0.010
GPS Method	Keynet VRS

PHOTOS:





Point ID	UA86
Project No.	26236
Project Name	DVRPC/NJ LIDAR
State	NEW JERSEY
County	BURLINGTON
Quad	JENKINS

Aerial Target	
LiDAR Ground Control	
X LiDAR QC Point	
New Control	
Photo ID	
Published Control	

Coordinate System	NAD83(2011)
	UTM – Zone 18N
	NAVD88
	GEOID12A
	Meters

Northing	Easting	Elevation
4392831.873	540007.719	12.712

Operator	STEVE MILLER
Receiver Model	Trimble R-8, Model 3
Receiver S/N	5135472526
Antenna Height	2.000 Meters

Date (MM-DD-YYYY)	06/13/2015
RMSE Hz	0.014
RMSE Z	0.016
GPS Method	RTK

PHOTOS:





Point ID	UA88
Project No.	26236
Project Name	DVRPC/NJ LIDAR
State	NEW JERSEY
County	BURLINGTON
Quad	GREEN BANK

Aerial Target	
LiDAR Ground Control	
X LiDAR QC Point	
New Control	
Photo ID	
Published Control	

Coordinate System	NAD83(2011)
	UTM – Zone 18N
	NAVD88
	GEOID12A
	Meters

Northing	Easting	Elevation
4382792.680	538696.855	1.422

Operator	STEVE MILLER
Receiver Model	Trimble R-8, Model 3
Receiver S/N	5135472526
Antenna Height	2.000 Meters

Date (MM-DD-YYYY)	06/12/2015
RMSE Hz	0.013
RMSE Z	0.013
GPS Method	RTK

PHOTOS:





Point ID	UA91
Project No.	26236
Project Name	DVRPC/NJ LIDAR
State	NEW JERSEY
County	BURLINGTON
Quad	NEW GREтна

Aerial Target	
LiDAR Ground Control	
X LiDAR QC Point	
New Control	
Photo ID	
Published Control	

Coordinate System	
NAD83(2011)	
UTM – Zone 18N	
NAVD88	
GEOID12A	
Meters	

Northing	Easting	Elevation
4382885.539	550166.416	3.886

Operator	STEVE MILLER
Receiver Model	Trimble R-8, Model 3
Receiver S/N	5133470976
Antenna Height	2.000 Meters

Date (MM-DD-YYYY)	06/12/2015
RMSE Hz	0.007
RMSE Z	0.010
GPS Method	RTK/STATIC

PHOTOS:





Point ID	UA101
Project No.	26236
Project Name	DVRPC/NJ LIDAR
State	NEW JERSEY
County	GLOUCESTER
Quad	BUENA

Aerial Target	
LiDAR Ground Control	
X LiDAR QC Point	
New Control	
Photo ID	
Published Control	

Coordinate System	NAD83(2011)
	UTM – Zone 18N
	NAVD88
	GEOID12A
	Meters

Northing	Easting	Elevation
4378326.224	499994.459	34.748

Operator	STEVE MILLER
Receiver Model	Trimble R-8, Model 3
Receiver S/N	5135472526
Antenna Height	2.000 Meters

Date (MM-DD-YYYY)	06/04/2015
RMSE Hz	0.013
RMSE Z	0.014
GPS Method	RTK

PHOTOS:





Point ID	UA102
Project No.	26236
Project Name	DVRPC/NJ LIDAR
State	NEW JERSEY
County	GLOUCESTER
Quad	HAMMONTOWN

	Aerial Target
	LiDAR Ground Control
X	LiDAR QC Point
	New Control
	Photo ID
	Published Control

Coordinate System
NAD83(2011)
UTM – Zone 18N
NAVD88
GEOID12A
Meters

Northing	Easting	Elevation
4392173.353	512389.211	35.446

Operator	STEVE MILLER
Receiver Model	Trimble R-8, Model 3
Receiver S/N	5135472526
Antenna Height	2.000 Meters

Date (MM-DD-YYYY)	06/04/2015
RMSE Hz	0.014
RMSE Z	0.017
GPS Method	RTK

PHOTOS:







Point ID	UA103
Project No.	26236
Project Name	DVRPC/NJ LIDAR
State	NEW JERSEY
County	CAMDEN
Quad	CLEMENTON

Aerial Target	
LiDAR Ground Control	
X LiDAR QC Point	
New Control	
Photo ID	
Published Control	

Coordinate System	
NAD83(2011)	
UTM – Zone 18N	
NAVD88	
GEOID12A	
Meters	

<b>Northing</b>	<b>Easting</b>	<b>Elevation</b>
4402489.139	508447.099	49.814

Operator	STEVE MILLER
Receiver Model	Trimble R-8, Model 3
Receiver S/N	5135472526
Antenna Height	2.000 Meters

Date (MM-DD-YYYY)	06/05/2015
RMSE Hz	0.013
RMSE Z	0.012
GPS Method	RTK

PHOTOS:





Point ID	UA104
Project No.	26236
Project Name	DVRPC/NJ LIDAR
State	NEW JERSEY
County	BURLINGTON
Quad	MOORESTOWN

Aerial Target	
LiDAR Ground Control	
X LiDAR QC Point	
New Control	
Photo ID	
Published Control	

Coordinate System	NAD83(2011)
	UTM – Zone 18N
	NAVD88
	GEOID12A
	Meters

<b>Northing</b>	<b>Easting</b>	<b>Elevation</b>
4424752.638	508922.168	13.176

Operator	STEVE MILLER
Receiver Model	Trimble R-8, Model 3
Receiver S/N	5135472526
Antenna Height	2.000 Meters

Date (MM-DD-YYYY)	06/05/2015
RMSE Hz	0.011
RMSE Z	0.012
GPS Method	RTK

PHOTOS:





Point ID	UA105
Project No.	26236
Project Name	DVRPC/NJ LIDAR
State	NEW JERSEY
County	BURLINGTON
Quad	COLUMBUS

Aerial Target	
LiDAR Ground Control	
X LiDAR QC Point	
New Control	
Photo ID	
Published Control	

Coordinate System	
NAD83(2011)	
UTM – Zone 18N	
NAVD88	
GEOID12A	
Meters	

Northing	Easting	Elevation
4436293.876	524367.991	22.641

Operator	STEVE MILLER
Receiver Model	Trimble R-8, Model 3
Receiver S/N	5135472526
Antenna Height	2.000 Meters

Date (MM-DD-YYYY)	06/05/2015
RMSE Hz	0.014
RMSE Z	0.014
GPS Method	RTK

PHOTOS:





Point ID	UA106
Project No.	26236
Project Name	DVRPC/NJ LIDAR
State	NEW JERSEY
County	BURLINGTON
Quad	NEW GRETNA

	Aerial Target
	LiDAR Ground Control
X	LiDAR QC Point
	New Control
	Photo ID
	Published Control

Coordinate System
NAD83(2011)
UTM – Zone 18N
NAVD88
GEOID12A
Meters

Northing	Easting	Elevation
4436293.876	524367.991	22.641

Operator	STEVE MILLER
Receiver Model	Trimble R-8, Model 3
Receiver S/N	5135472526
Antenna Height	2.000 Meters

Date (MM-DD-YYYY)	06/12/2015
RMSE Hz	0.013
RMSE Z	0.014
GPS Method	RTK

PHOTOS:





Point ID	UA107
Project No.	26236
Project Name	DVRPC/NJ LIDAR
State	NEW JERSEY
County	BURLINGTON
Quad	JENKINS

Aerial Target	
LiDAR Ground Control	
X LiDAR QC Point	
New Control	
Photo ID	
Published Control	

Coordinate System	NAD83(2011)
	UTM – Zone 18N
	NAVD88
	GEOID12A
	Meters

Northing	Easting	Elevation
4386195.281	533177.792	1.160

Operator	STEVE MILLER
Receiver Model	Trimble R-8, Model 3
Receiver S/N	5135472526
Antenna Height	2.000 Meters

Date (MM-DD-YYYY)	06/13/2015
RMSE Hz	0.015
RMSE Z	0.016
GPS Method	RTK

PHOTOS:





Point ID	UA109
Project No.	26236
Project Name	DVRPC/NJ LIDAR
State	NEW JERSEY
County	BURLINGTON
Quad	MEDFORD LAKES

Aerial Target	
LiDAR Ground Control	
X LiDAR QC Point	
New Control	
Photo ID	
Published Control	

Coordinate System	NAD83(2011)
	UTM – Zone 18N
	NAVD88
	GEOID12A
	Meters

<b>Northing</b>	<b>Easting</b>	<b>Elevation</b>
4404577.477	521121.356	24.970

Operator	STEVE MILLER
Receiver Model	Trimble R-8, Model 3
Receiver S/N	5135472526
Antenna Height	2.000 Meters

Date (MM-DD-YYYY)	06/14/2015
RMSE Hz	0.013
RMSE Z	0.014
GPS Method	RTK

PHOTOS:





Point ID	UA110
Project No.	26236
Project Name	DVRPC/NJ LIDAR
State	NEW JERSEY
County	BURLINGTON
Quad	INDIAN MILLS

Aerial Target	
LiDAR Ground Control	
X LiDAR QC Point	
New Control	
Photo ID	
Published Control	

Coordinate System	NAD83(2011)
	UTM – Zone 18N
	NAVD88
	GEOID12A
	Meters

Northing	Easting	Elevation
4454810.216	536238.904	30.810

Operator	STEVE MILLER
Receiver Model	Trimble R-8, Model 3
Receiver S/N	5135472526
Antenna Height	2.000 Meters

Date (MM-DD-YYYY)	06/14/2015
RMSE Hz	0.014
RMSE Z	0.014
GPS Method	RTK

PHOTOS:





Point ID	UA111
Project No.	26236
Project Name	DVRPC/NJ LIDAR
State	NEW JERSEY
County	BURLINGTON
Quad	ALLENTOWN

Aerial Target	
LiDAR Ground Control	
X LiDAR QC Point	
New Control	
Photo ID	
Published Control	

Coordinate System	NAD83(2011)
	UTM – Zone 18N
	NAVD88
	GEOID12A
	Meters

Northing	Easting	Elevation
4454810.216	536238.904	30.810

Operator	STEVE MILLER
Receiver Model	Trimble R-8, Model 3
Receiver S/N	5135472526
Antenna Height	2.000 Meters

Date (MM-DD-YYYY)	06/15/2015
RMSE Hz	0.013
RMSE Z	0.013
GPS Method	RTK

PHOTOS:







Point ID	NVA56
Project No.	26236
Project Name	DELAWARE VALLEY
State	NEW JERSEY
County	GLOUCESTER
Quad	WOODSTOWN

	Aerial Target
	LiDAR Ground Control
X	LiDAR QC Point
	New Control
	Photo ID
	Published Control

Coordinate System
NAD83(2011)
UTM – Zone 18N
NAVD88
GEOID12A
Meters

Northing	Easting	Elevation
4396881.766	477852.955	32.082

Operator	STEVE MILLER
Receiver Model	Trimble R-8, Model 3
Receiver S/N	5135472526
Antenna Height	2.000 Meters

Date (MM-DD-YYYY)	06/02/2015
RMSE Hz	0.012
RMSE Z	0.013
GPS Method	RTK

PHOTOS:





Point ID	NVA69
Project No.	26236
Project Name	DVRPC/NJ LIDAR
State	NEW JERSEY
County	BURLINGTON
Quad	INDIAN MILLS

	Aerial Target
	LiDAR Ground Control
X	LiDAR QC Point
	New Control
	Photo ID
	Published Control

Coordinate System
NAD83(2011)
UTM – Zone 18N
NAVD88
GEOID12A
Meters

Northing	Easting	Elevation
4413143.124	529610.287	29.705

Operator	STEVE MILLER
Receiver Model	Trimble R-8, Model 3
Receiver S/N	5135472526
Antenna Height	2.000 Meters

Date (MM-DD-YYYY)	06/14/2015
RMSE Hz	0.013
RMSE Z	0.014
GPS Method	RTK

PHOTOS:





Point ID	NVA74
Project No.	26236
Project Name	DVRPC/NJ LIDAR
State	NEW JERSEY
County	GLOUCESTER
Quad	PITTMAN EAST

Aerial Target	
LiDAR Ground Control	
X LiDAR QC Point	
New Control	
Photo ID	
Published Control	

Coordinate System	NAD83(2011)
	UTM – Zone 18N
	NAVD88
	GEOID12A
	Meters

<b>Northing</b>	<b>Easting</b>	<b>Elevation</b>
4395708.842	494333.292	44.820

Operator	STEVE MILLER
Receiver Model	Trimble R-8, Model 3
Receiver S/N	5135472526
Antenna Height	2.000 Meters

Date (MM-DD-YYYY)	06/03/2015
RMSE Hz	0.013
RMSE Z	0.013
GPS Method	RTK

PHOTOS:





Point ID	NVA76
Project No.	26236
Project Name	DVRPC/NJ LIDAR
State	NEW JERSEY
County	GLOUCESTER
Quad	PITTMAN WEST

Aerial Target	
LiDAR Ground Control	
X LiDAR QC Point	
New Control	
Photo ID	
Published Control	

Coordinate System	NAD83(2011)
	UTM – Zone 18N
	NAVD88
	GEOID12A
	Meters

Northing	Easting	Elevation
4388352.625	488420.567	39.986

Operator	STEVE MILLER
Receiver Model	Trimble R-8, Model 3
Receiver S/N	5135472526
Antenna Height	2.000 Meters

Date (MM-DD-YYYY)	06/03/2015
RMSE Hz	0.013
RMSE Z	0.013
GPS Method	RTK

PHOTOS:





Point ID	NVA77
Project No.	26236
Project Name	DVRPC/NJ LIDAR
State	NEW JERSEY
County	GLOUCESTER
Quad	NEWFIELD

Aerial Target	
LiDAR Ground Control	
X LiDAR QC Point	
New Control	
Photo ID	
Published Control	

Coordinate System	NAD83(2011)
	UTM – Zone 18N
	NAVD88
	GEOID12A
	Meters

<b>Northing</b>	<b>Easting</b>	<b>Elevation</b>
4381620.817	495377.489	31.774

Operator	STEVE MILLER
Receiver Model	Trimble R-8, Model 3
Receiver S/N	5135472526
Antenna Height	2.000 Meters

Date (MM-DD-YYYY)	06/04/2015
RMSE Hz	0.013
RMSE Z	0.016
GPS Method	RTK

PHOTOS:





Point ID	NVA100
Project No.	26236
Project Name	DVRPC/NJ LIDAR
State	NEW JERSEY
County	GLOUCESTER
Quad	RUNNEMEDE

Aerial Target	
LiDAR Ground Control	
X LiDAR QC Point	
New Control	
Photo ID	
Published Control	

Coordinate System	NAD83(2011)
	UTM – Zone 18N
	NAVD88
	GEOID12A
	Meters

Northing	Easting	Elevation
4401513.802	486031.316	42.815

Operator	STEVE MILLER
Receiver Model	Trimble R-8, Model 3
Receiver S/N	5135472526
Antenna Height	2.000 Meters

Date (MM-DD-YYYY)	06/03/2015
RMSE Hz	0.013
RMSE Z	0.015
GPS Method	RTK

PHOTOS:





## VEGETATION POINT DATA SHEETS



## **FORESTED POINT DATA SHEETS**





Point ID	FO01A
Project No.	26236
Project Name	DELEWARE VALLEY LIDAR
State	NEW JERSEY
County	BURLINGTON
Quad	JENKINS

	Aerial Target
	LiDAR Ground Control
X	LiDAR QC Point
	New Control
	Photo ID
	Published Control

Coordinate System
NAD83(2011)
UTM – Zone 18N
NAVD88
GEOID12A
Meters

Northing	Easting	Elevation
4392850.431	539950.795	11.805

Operator	ZEKE INGRAM
Instrument Model	Trimble M3 2"
Date (MM-DD-YYYY)	07-07-2015
Occupy PT	BE71
Back Sight PT	CP73
RMSE Hz	0.02
RMSE Z	0.02

PHOTOS:





Point ID	FO02A
Project No.	26236
Project Name	DELEWARE VALLEY LIDAR
State	PENNSYLVANIA
County	MONTGOMERY
Quad	NORRISTOWN

	Aerial Target
	LiDAR Ground Control
X	LiDAR QC Point
	New Control
	Photo ID
	Published Control

Coordinate System	NAD83(2011)
	UTM - Zone 18N
	NAVD88
	GEOID12A
	Meters

Northing	Easting	Elevation
4432990.871	477194.935	104.332

Operator	ZEKE INGRAM
Instrument Model	Trimble M3 2"
Date (MM-DD-YYYY)	07-09-2015
Occupy PT	UA31
Back Sight PT	FO02ABS
RMSE Hz	0.02
RMSE Z	0.02

PHOTOS:





Point ID	FO03A
Project No.	26236
Project Name	DELEWARE VALLEY LIDAR
State	PENNSYLVANIA
County	MONTGOMERY
Quad	AMBLER

	Aerial Target
	LiDAR Ground Control
X	LiDAR QC Point
	New Control
	Photo ID
	Published Control

Coordinate System	
NAD83(2011)	
UTM - Zone 18N	
NAVD88	
GEOID12A	
Meters	

Northing	Easting	Elevation
4448835.607	480563.636	99.761

Operator	ZEKE INGRAM
Instrument Model	Trimble M3 2"
Date (MM-DD-YYYY)	07-09-2015
Occupy PT	UA22
Back Sight PT	FO03ABS
RMSE Hz	0.02
RMSE Z	0.02

PHOTOS:





Point ID	FO04A
Project No.	26236
Project Name	DELEWARE VALLEY LIDAR
State	NEW JERSEY
County	CAMDEN
Quad	MEDFORD LAKES

	Aerial Target
	LiDAR Ground Control
X	LiDAR QC Point
	New Control
	Photo ID
	Published Control

Coordinate System	NAD83(2011)
	UTM - Zone 18N
	NAVD88
	GEOID12A
	Meters

Northing	Easting	Elevation
4392850.431	539950.795	11.805

Operator	ZEKE INGRAM
Instrument Model	Trimble M3 2"
Date (MM-DD-YYYY)	07-07-2015
Occupy PT	BE58
Back Sight PT	UA71
RMSE Hz	0.02
RMSE Z	0.02

PHOTOS:





Point ID	FO05A
Project No.	26236
Project Name	DELEWARE VALLEY LIDAR
State	NEW JERSEY
County	GLOUCESTER
Quad	BUENA

	Aerial Target
	LiDAR Ground Control
X	LiDAR QC Point
	New Control
	Photo ID
	Published Control

Coordinate System
NAD83(2011)
UTM – Zone 18N
NAVD88
GEOID12A
Meters

Northing	Easting	Elevation
4378351.748	500007.060	34.347

Operator	ZEKE INGRAM
Instrument Model	Trimble M3 2"
Date (MM-DD-YYYY)	07-07-2015
Occupy PT	UA101
Back Sight PT	BE55
RMSE Hz	0.02
RMSE Z	0.02

PHOTOS:





Point ID	FO06A
Project No.	26236
Project Name	DELEWARE VALLEY LIDAR
State	PENNSYLVANIA
County	DELAWARE
Quad	MARCUS HOOK

	Aerial Target
	LiDAR Ground Control
X	LiDAR QC Point
	New Control
	Photo ID
	Published Control

Coordinate System
NAD83(2011)
UTM – Zone 18N
NAVD88
GEOID12A
Meters

Northing	Easting	Elevation
4411244.473	459837.455	69.465

Operator	ZEKE INGRAM
Instrument Model	Trimble M3 2"
Date (MM-DD-YYYY)	07-07-2015
Occupy PT	UA25
Back Sight PT	TW11
RMSE Hz	0.02
RMSE Z	0.02

PHOTOS:





Point ID	FO07A
Project No.	26236
Project Name	DELEWARE VALLEY LIDAR
State	PENNSYLVANIA
County	MONTGOMERY
Quad	PERKIOMENVILLE

	Aerial Target
	LiDAR Ground Control
X	LiDAR QC Point
	New Control
	Photo ID
	Published Control

Coordinate System
NAD83(2011)
UTM – Zone 18N
NAVD88
GEOID12A
Meters

Northing	Easting	Elevation
4459006.563	465093.687	56.823

Operator	ZEKE INGRAM
Instrument Model	Trimble M3 2"
Date (MM-DD-YYYY)	07-09-2015
Occupy PT	TW5
Back Sight PT	FO07ABS
RMSE Hz	0.03
RMSE Z	0.03

PHOTOS:





Point ID	FO08A
Project No.	26236
Project Name	DELEWARE VALLEY LIDAR
State	PENNSYLVANIA
County	BUCKS
Quad	DOYLESTOWN

	Aerial Target
	LiDAR Ground Control
X	LiDAR QC Point
	New Control
	Photo ID
	Published Control

Coordinate System
NAD83(2011)
UTM – Zone 18N
NAVD88
GEOID12A
Meters

Northing	Easting	Elevation
4467819.289	488671.030	136.899

Operator	ZEKE INGRAM
Instrument Model	Trimble M3 2"
Date (MM-DD-YYYY)	07-09-2015
Occupy PT	UA15
Back Sight PT	FO08ABS
RMSE Hz	0.020
RMSE Z	0.020

PHOTOS:







Point ID	FO09A
Project No.	26236
Project Name	DELEWARE VALLEY LIDAR
State	PENNSYLVANIA
County	BUCKS
Quad	LANGHORNE

	Aerial Target
	LiDAR Ground Control
X	LiDAR QC Point
	New Control
	Photo ID
	Published Control

Coordinate System
NAD83(2011)
UTM – Zone 18N
NAVD88
GEOID12A
Meters

Northing	Easting	Elevation
4467819.289	488671.030	136.899

Operator	ZEKE INGRAM
Instrument Model	Trimble M3 2"
Date (MM-DD-YYYY)	07-09-2015
Occupy PT	TW15
Back Sight PT	FO09ABS
RMSE Hz	0.020
RMSE Z	0.020

PHOTOS:





Point ID	FO10A
Project No.	26236
Project Name	DELEWARE VALLEY LIDAR
State	PENNSYLVANIA
County	PHILADEPHIA
Quad	GERMANTOWN

	Aerial Target
	LiDAR Ground Control
X	LiDAR QC Point
	New Control
	Photo ID
	Published Control

Coordinate System	
NAD83(2011)	
UTM – Zone 18N	
NAVD88	
GEOID12A	
Meters	

Northing	Easting	Elevation
4428542.428	482767.100	33.187

Operator	ZEKE INGRAM
Instrument Model	Trimble M3 2"
Date (MM-DD-YYYY)	07-08-2015
Occupy PT	UA32
Back Sight PT	TW13
RMSE Hz	0.020
RMSE Z	0.020

PHOTOS:





Point ID	FO11A
Project No.	26236
Project Name	DELEWARE VALLEY LIDAR
State	PENNSYLVANIA
County	MONTGOMERY
Quad	COLLEGEVILLE

	Aerial Target
	LiDAR Ground Control
X	LiDAR QC Point
	New Control
	Photo ID
	Published Control

Coordinate System
NAD83(2011)
UTM – Zone 18N
NAVD88
GEOID12A
Meters

Northing	Easting	Elevation
4451151.130	461691.499	34.248

Operator	ZEKE INGRAM
Instrument Model	Trimble M3 2"
Date (MM-DD-YYYY)	07-08-2015
Occupy PT	BE10
Back Sight PT	TW4
RMSE Hz	0.020
RMSE Z	0.020

PHOTOS:





Point ID	FO12A
Project No.	26236
Project Name	DELEWARE VALLEY LIDAR
State	PENNSYLVANIA
County	MONTGOMERY
Quad	PHOENIXVILLE

	Aerial Target
	LiDAR Ground Control
X	LiDAR QC Point
	New Control
	Photo ID
	Published Control

Coordinate System	
NAD83(2011)	
UTM – Zone 18N	
NAVD88	
GEOID12A	
Meters	

Northing	Easting	Elevation
4454451.159	448333.516	44.416

Operator	ZEKE INGRAM
Instrument Model	Trimble M3 2"
Date (MM-DD-YYYY)	07-08-2015
Occupy PT	TW3
Back Sight PT	UA8
RMSE Hz	0.020
RMSE Z	0.020

PHOTOS:





Point ID	FO13A
Project No.	26236
Project Name	DELEWARE VALLEY LIDAR
State	PENNSYLVANIA
County	MONTGOMERY
Quad	PERKIOMENVILLE

	Aerial Target
	LiDAR Ground Control
X	LiDAR QC Point
	New Control
	Photo ID
	Published Control

Coordinate System
NAD83(2011)
UTM – Zone 18N
NAVD88
GEOID12A
Meters

Northing	Easting	Elevation
4467092.705	459083.273	97.661

Operator	ZEKE INGRAM
Instrument Model	Trimble M3 2"
Date (MM-DD-YYYY)	07-08-2015
Occupy PT	UA6
Back Sight PT	TW2
RMSE Hz	0.030
RMSE Z	0.030

PHOTOS:





Point ID	FO14A
Project No.	26236
Project Name	DELEWARE VALLEY LIDAR
State	PENNSYLVANIA
County	BUCKS
Quad	BEDMINSTER

	Aerial Target
	LiDAR Ground Control
X	LiDAR QC Point
	New Control
	Photo ID
	Published Control

Coordinate System	
NAD83(2011)	
UTM – Zone 18N	
NAVD88	
GEOID12A	
Meters	

Northing	Easting	Elevation
4483076.108	484510.426	159.470

Operator	ZEKE INGRAM
Instrument Model	Trimble M3 2"
Date (MM-DD-YYYY)	07-08-2015
Occupy PT	BE2
Back Sight PT	TW1
RMSE Hz	0.020
RMSE Z	0.020

PHOTOS:





Point ID	FO15A
Project No.	26236
Project Name	DELEWARE VALLEY LIDAR
State	PENNSYLVANIA
County	BUCKS
Quad	LUMBERVILLE

	Aerial Target
	LiDAR Ground Control
X	LiDAR QC Point
	New Control
	Photo ID
	Published Control

Coordinate System	
NAD83(2011)	
UTM – Zone 18N	
NAVD88	
GEOID12A	
Meters	

Northing	Easting	Elevation
4477266.087	492415.797	133.415

Operator	ZEKE INGRAM
Instrument Model	Trimble M3 2"
Date (MM-DD-YYYY)	07-08-2015
Occupy PT	UA17
Back Sight PT	TW7
RMSE Hz	0.020
RMSE Z	0.020

PHOTOS:





Point ID	FO16
Project No.	26236
Project Name	DELEWARE VALLEY LIDAR
State	NEW JERSEY
County	MERCER
Quad	PRINCETON

	Aerial Target
	LiDAR Ground Control
X	LiDAR QC Point
	New Control
	Photo ID
	Published Control

Coordinate System
NAD83(2011)
UTM – Zone 18N
NAVD88
GEOID12A
Meters

Northing	Easting	Elevation
4468118.537	522564.781	74.651

Operator	STEVE MILLER
Instrument Model	Trimble M3 2"
Date (MM-DD-YYYY)	06-15-2015
Occupy PT	UA43
Back Sight PT	TW16
RMSE Hz	0.020
RMSE Z	0.020

PHOTOS:







Point ID	FO17
Project No.	26236
Project Name	DELEWARE VALLEY LIDAR
State	NEW JERSEY
County	MERCER
Quad	ALLENTOWN

	Aerial Target
	LiDAR Ground Control
X	LiDAR QC Point
	New Control
	Photo ID
	Published Control

Coordinate System
NAD83(2011)
UTM – Zone 18N
NAVD88
GEOID12A
Meters

Northing	Easting	Elevation
4454780.149	536197.369	29.670

Operator	STEVE MILLER
Instrument Model	Trimble M3 2"
Date (MM-DD-YYYY)	06-15-2015
Occupy PT	UA111
Back Sight PT	CP79
RMSE Hz	0.020
RMSE Z	0.020

PHOTOS:





Point ID	FO18
Project No.	26236
Project Name	DELEWARE VALLEY LIDAR
State	NEW JERSEY
County	MERCER
Quad	TRENTON EAST

	Aerial Target
	LiDAR Ground Control
X	LiDAR QC Point
	New Control
	Photo ID
	Published Control

Coordinate System
NAD83(2011)
UTM – Zone 18N
NAVD88
GEOID12A
Meters

Northing	Easting	Elevation
4449401.214	524011.950	18.523

Operator	STEVE MILLER
Instrument Model	Trimble M3 2"
Date (MM-DD-YYYY)	06-15-2015
Occupy PT	NVA46
Back Sight PT	TW18
RMSE Hz	0.020
RMSE Z	0.020

PHOTOS:





Point ID	FO19
Project No.	26236
Project Name	DELEWARE VALLEY LIDAR
State	NEW JERSEY
County	BURLINGTON
Quad	BEVERLY

	Aerial Target
	LiDAR Ground Control
X	LiDAR QC Point
	New Control
	Photo ID
	Published Control

Coordinate System
NAD83(2011)
UTM – Zone 18N
NAVD88
GEOID12A
Meters

Northing	Easting	Elevation
4435696.499	510133.636	3.503

Operator	STEVE MILLER
Instrument Model	Trimble M3 2"
Date (MM-DD-YYYY)	06-07-2015
Occupy PT	TW19
Back Sight PT	BE63
RMSE Hz	0.020
RMSE Z	0.020

PHOTOS:





Point ID	FO20
Project No.	26236
Project Name	DELEWARE VALLEY LIDAR
State	NEW JERSEY
County	CAMDEN
Quad	CAMDEN

	Aerial Target
	LiDAR Ground Control
X	LiDAR QC Point
	New Control
	Photo ID
	Published Control

Coordinate System
NAD83(2011)
UTM – Zone 18N
NAVD88
GEOID12A
Meters

Northing	Easting	Elevation
4425013.081	497090.994	13.071

Operator	STEVE MILLER
Instrument Model	Trimble M3 2"
Date (MM-DD-YYYY)	06-07-2015
Occupy PT	UA51
Back Sight PT	CP62
RMSE Hz	0.020
RMSE Z	0.020

PHOTOS:





Point ID	FO21
Project No.	26236
Project Name	DELEWARE VALLEY LIDAR
State	NEW JERSEY
County	BURLINGTON
Quad	WOODBURY

	Aerial Target
	LiDAR Ground Control
X	LiDAR QC Point
	New Control
	Photo ID
	Published Control

Coordinate System
NAD83(2011)
UTM – Zone 18N
NAVD88
GEOID12A
Meters

Northing	Easting	Elevation
4411405.804	485086.466	2.244

Operator	STEVE MILLER
Instrument Model	Trimble M3 2"
Date (MM-DD-YYYY)	06-15-2015
Occupy PT	TW21
Back Sight PT	NVA53
RMSE Hz	0.020
RMSE Z	0.020

PHOTOS:





Point ID	FO22
Project No.	26236
Project Name	DELEWARE VALLEY LIDAR
State	NEW JERSEY
County	GLOUCESTER
Quad	BRIDGEPORT

	Aerial Target
	LiDAR Ground Control
X	LiDAR QC Point
	New Control
	Photo ID
	Published Control

Coordinate System
NAD83(2011)
UTM - Zone 18N
NAVD88
GEOID12A
Meters

Northing	Easting	Elevation
4402115.168	469201.798	1.690

Operator	STEVE MILLER
Instrument Model	Trimble M3 2"
Date (MM-DD-YYYY)	06-07-2015
Occupy PT	NVA55
Back Sight PT	BSFO22
RMSE Hz	0.020
RMSE Z	0.020

PHOTOS:





Point ID	FO23
Project No.	26236
Project Name	DELEWARE VALLEY LIDAR
State	NEW JERSEY
County	GLOUCESTER
Quad	PITTMAN WEST

	Aerial Target
	LiDAR Ground Control
X	LiDAR QC Point
	New Control
	Photo ID
	Published Control

Coordinate System	NAD83(2011)
	UTM – Zone 18N
	NAVD88
	GEOID12A
	Meters

Northing	Easting	Elevation
4398113.571	487270.762	39.004

Operator	STEVE MILLER
Instrument Model	Trimble M3 2"
Date (MM-DD-YYYY)	06-07-2015
Occupy PT	TPFO23
Back Sight PT	CP45
RMSE Hz	0.020
RMSE Z	0.020

PHOTOS:





Point ID	FO24
Project No.	26236
Project Name	DELEWARE VALLEY LIDAR
State	NEW JERSEY
County	CAMDEN
Quad	CLEMENTON

	Aerial Target
	LiDAR Ground Control
X	LiDAR QC Point
	New Control
	Photo ID
	Published Control

Coordinate System
NAD83(2011)
UTM - Zone 18N
NAVD88
GEOID12A
Meters

Northing	Easting	Elevation
4412607.699	504547.197	42.684

Operator	STEVE MILLER
Instrument Model	Trimble M3 2"
Date (MM-DD-YYYY)	06-07-2015
Occupy PT	BE62
Back Sight PT	CP60
RMSE Hz	0.020
RMSE Z	0.020

PHOTOS:







Point ID	FO25
Project No.	26236
Project Name	DELEWARE VALLEY LIDAR
State	NEW JERSEY
County	BURLINGTON
Quad	MT. HOLLY

	Aerial Target
	LiDAR Ground Control
X	LiDAR QC Point
	New Control
	Photo ID
	Published Control

Coordinate System
NAD83(2011)
UTM – Zone 18N
NAVD88
GEOID12A
Meters

Northing	Easting	Elevation
4407511.249	519874.688	31.721

Operator	STEVE MILLER
Instrument Model	Trimble M3 2"
Date (MM-DD-YYYY)	06-07-2015
Occupy PT	NVA67
Back Sight PT	UA62
RMSE Hz	0.020
RMSE Z	0.020

PHOTOS:





Point ID	FO26
Project No.	26236
Project Name	DELEWARE VALLEY LIDAR
State	NEW JERSEY
County	BURLINGTON
Quad	CAMP DIX

	Aerial Target
	LiDAR Ground Control
X	LiDAR QC Point
	New Control
	Photo ID
	Published Control

Coordinate System
NAD83(2011)
UTM – Zone 18N
NAVD88
GEOID12A
Meters

Northing	Easting	Elevation
4439967.031	532507.290	29.084

Operator	STEVE MILLER
Instrument Model	Trimble M3 2"
Date (MM-DD-YYYY)	06-15-2015
Occupy PT	TW26
Back Sight PT	NVA65
RMSE Hz	0.020
RMSE Z	0.020

PHOTOS:





Point ID	FO27
Project No.	26236
Project Name	DELEWARE VALLEY LIDAR
State	NEW JERSEY
County	BURLINGTON
Quad	BROWNS MILL

	Aerial Target
	LiDAR Ground Control
X	LiDAR QC Point
	New Control
	Photo ID
	Published Control

Coordinate System
NAD83(2011)
UTM – Zone 18N
NAVD88
GEOID12A
Meters

Northing	Easting	Elevation
4426898.197	538727.367	29.510

Operator	STEVE MILLER
Instrument Model	Trimble M3 2"
Date (MM-DD-YYYY)	06-15-2015
Occupy PT	TW27
Back Sight PT	NVA66
RMSE Hz	0.020
RMSE Z	0.020

PHOTOS:





Point ID	FO28
Project No.	26236
Project Name	DELEWARE VALLEY LIDAR
State	NEW JERSEY
County	BURLINGTON
Quad	MEDFORD LAKES

	Aerial Target
	LiDAR Ground Control
X	LiDAR QC Point
	New Control
	Photo ID
	Published Control

Coordinate System
NAD83(2011)
UTM – Zone 18N
NAVD88
GEOID12A
Meters

Northing	Easting	Elevation
4407511.249	519874.688	31.721

Operator	STEVE MILLER
Instrument Model	Trimble M3 2"
Date (MM-DD-YYYY)	06-07-2015
Occupy PT	TW28
Back Sight PT	CP76
RMSE Hz	0.020
RMSE Z	0.020

PHOTOS:





Point ID	FO29
Project No.	26236
Project Name	DELEWARE VALLEY LIDAR
State	NEW JERSEY
County	BURLINGTON
Quad	WILLIAMSTOWN

	Aerial Target
	LiDAR Ground Control
X	LiDAR QC Point
	New Control
	Photo ID
	Published Control

Coordinate System
NAD83(2011)
UTM – Zone 18N
NAVD88
GEOID12A
Meters

Northing	Easting	Elevation
4396234.932	506624.298	46.255

Operator	STEVE MILLER
Instrument Model	Trimble M3 2"
Date (MM-DD-YYYY)	06-07-2015
Occupy PT	CP55
Back Sight PT	BE56
RMSE Hz	0.020
RMSE Z	0.020

PHOTOS:





Point ID	FO30
Project No.	26236
Project Name	DELEWARE VALLEY LIDAR
State	NEW JERSEY
County	BURLINGTON
Quad	NEWFIELD

	Aerial Target
	LiDAR Ground Control
X	LiDAR QC Point
	New Control
	Photo ID
	Published Control

Coordinate System
NAD83(2011)
UTM – Zone 18N
NAVD88
GEOID12A
Meters

Northing	Easting	Elevation
4380808.456	496039.040	35.891

Operator	STEVE MILLER
Instrument Model	Trimble M3 2"
Date (MM-DD-YYYY)	06-07-2015
Occupy PT	TPFO30
Back Sight PT	BE54
RMSE Hz	0.020
RMSE Z	0.020

PHOTOS:





Point ID	FO31
Project No.	26236
Project Name	DELEWARE VALLEY LIDAR
State	NEW JERSEY
County	BURLINGTON
Quad	CHATSWORTH

	Aerial Target
	LiDAR Ground Control
X	LiDAR QC Point
	New Control
	Photo ID
	Published Control

Coordinate System
NAD83(2011)
UTM – Zone 18N
NAVD88
GEOID12A
Meters

Northing	Easting	Elevation
4408037.076	535359.109	33.671

Operator	STEVE MILLER
Instrument Model	Trimble M3 2"
Date (MM-DD-YYYY)	06-07-2015
Occupy PT	NVA81
Back Sight PT	TW31
RMSE Hz	0.020
RMSE Z	0.020

PHOTOS:





Point ID	FO32
Project No.	26236
Project Name	DELEWARE VALLEY LIDAR
State	NEW JERSEY
County	BURLINGTON
Quad	WHITING

	Aerial Target
	LiDAR Ground Control
X	LiDAR QC Point
	New Control
	Photo ID
	Published Control

Coordinate System
NAD83(2011)
UTM – Zone 18N
NAVD88
GEOID12A
Meters

Northing	Easting	Elevation
4407678.700	549315.591	58.132

Operator	STEVE MILLER
Instrument Model	Trimble M3 2"
Date (MM-DD-YYYY)	06-15-2015
Occupy PT	TW32
Back Sight PT	NVA83
RMSE Hz	0.020
RMSE Z	0.020

PHOTOS:







Point ID	FO33
Project No.	26236
Project Name	DELEWARE VALLEY LIDAR
State	NEW JERSEY
County	BURLINGTON
Quad	MEDFORD LAKES

	Aerial Target
	LiDAR Ground Control
X	LiDAR QC Point
	New Control
	Photo ID
	Published Control

Coordinate System
NAD83(2011)
UTM – Zone 18N
NAVD88
GEOID12A
Meters

Northing	Easting	Elevation
4398930.007	540127.971	17.468

Operator	STEVE MILLER
Instrument Model	Trimble M3 2"
Date (MM-DD-YYYY)	06-07-2015
Occupy PT	TPFO33
Back Sight PT	CP74
RMSE Hz	0.020
RMSE Z	0.020

PHOTOS:





Point ID	FO34
Project No.	26236
Project Name	DELEWARE VALLEY LIDAR
State	NEW JERSEY
County	BURLINGTON
Quad	GREEN BANK

	Aerial Target
	LiDAR Ground Control
X	LiDAR QC Point
	New Control
	Photo ID
	Published Control

Coordinate System
NAD83(2011)
UTM – Zone 18N
NAVD88
GEOID12A
Meters

Northing	Easting	Elevation
4385254.867	536160.096	7.442

Operator	STEVE MILLER
Instrument Model	Trimble M3 2"
Date (MM-DD-YYYY)	06-07-2015
Occupy PT	CP72
Back Sight PT	NVA87
RMSE Hz	0.020
RMSE Z	0.020

PHOTOS:





Point ID	FO35
Project No.	26236
Project Name	DELEWARE VALLEY LIDAR
State	NEW JERSEY
County	BURLINGTON
Quad	NEW GRETN

	Aerial Target
	LiDAR Ground Control
X	LiDAR QC Point
	New Control
	Photo ID
	Published Control

Coordinate System
NAD83(2011)
UTM - Zone 18N
NAVD88
GEOID12A
Meters

Northing	Easting	Elevation
4386214.005	545688.299	9.793

Operator	STEVE MILLER
Instrument Model	Trimble M3 2"
Date (MM-DD-YYYY)	06-07-2015
Occupy PT	BE69
Back Sight PT	CP70
RMSE Hz	0.020
RMSE Z	0.020

PHOTOS:





## TALL WEED POINT DATA SHEETS



Point ID	TW2
Project No.	26236
Project Name	DELAWARE VALLEY LiDAR
State	Pennsylvania
County	Montgomery
Quad	Perkiomenville

Aerial Target	
LiDAR Ground Control	
X LiDAR QC Point	
New Control	
Photo ID	
Published Control	

Coordinate System	NAD83(2011)
	UTM – Zone 18N
	NAVD88
	GEOID12A
	Meters

Northing	Easting	Elevation
4467114.015	459051.233	96.337

Operator	Kevin Chapman
Receiver Model	Trimble R-8, Model 3
Receiver S/N	5106461067
Antenna Height	2.000 Meters

Date (MM-DD-YYYY)	04/18/2015
RMSE Hz	0.018
RMSE Z	0.019
GPS Method	Keynet VRS

PHOTOS:





Point ID	TW3
Project No.	26236
Project Name	DELAWARE VALLEY LiDAR
State	Pennsylvania
County	Montgomery
Quad	Phoenixville

	Aerial Target
	LiDAR Ground Control
X	LiDAR QC Point
	New Control
	Photo ID
	Published Control

Coordinate System
NAD83(2011)
UTM – Zone 18N
NAVD88
GEOID12A
Meters

Northing	Easting	Elevation
4454423.676	448316.382	43.964

Operator	Kevin Chapman
Receiver Model	Trimble R-8, Model 3
Receiver S/N	5106461067
Antenna Height	2.000 Meters

Date (MM-DD-YYYY)	04/17/2015
RMSE Hz	0.020
RMSE Z	0.021
GPS Method	Keynet VRS

PHOTOS:





Point ID	TW4
Project No.	26236
Project Name	DELAWARE VALLEY LiDAR
State	Pennsylvania
County	Montgomery
Quad	Collegeville

	Aerial Target
	LiDAR Ground Control
X	LiDAR QC Point
	New Control
	Photo ID
	Published Control

Coordinate System
NAD83(2011)
UTM – Zone 18N
NAVD88
GEOID12A
Meters

Northing	Easting	Elevation
4454423.676	448316.382	43.964

Operator	Kevin Chapman
Receiver Model	Trimble R-8, Model 3
Receiver S/N	5106461067
Antenna Height	2.000 Meters

Date (MM-DD-YYYY)	05/06/2015
RMSE Hz	0.008
RMSE Z	0.011
GPS Method	Keynet VRS

PHOTOS:





Point ID	TW6
Project No.	26236
Project Name	DELAWARE VALLEY LiDAR
State	Pennsylvania
County	Bucks
Quad	Doylestown

Aerial Target	
LiDAR Ground Control	
X LiDAR QC Point	
New Control	
Photo ID	
Published Control	

Coordinate System	
NAD83(2011)	
UTM – Zone 18N	
NAVD88	
GEOID12A	
Meters	

<b>Northing</b>	<b>Easting</b>	<b>Elevation</b>
4464853.427	481345.363	194.172

Operator	Kevin Chapman
Receiver Model	Trimble R-8, Model 3
Receiver S/N	5106461067
Antenna Height	2.000 Meters

Date (MM-DD-YYYY)	04/24/2015
RMSE Hz	0.015
RMSE Z	0.016
GPS Method	Keynet VRS

PHOTOS:







Point ID	TW7
Project No.	26236
Project Name	DELAWARE VALLEY LiDAR
State	Pennsylvania
County	Bucks
Quad	Lumberville

Aerial Target	
LiDAR Ground Control	
X LiDAR QC Point	
New Control	
Photo ID	
Published Control	

Coordinate System	NAD83(2011)
	UTM – Zone 18N
	NAVD88
	GEOID12A
	Meters

<b>Northing</b>	<b>Easting</b>	<b>Elevation</b>
4477270.588	492492.453	131.936

Operator	Kevin Chapman
Receiver Model	Trimble R-8, Model 3
Receiver S/N	5106461067
Antenna Height	2.000 Meters

Date (MM-DD-YYYY)	04/24/2015
RMSE Hz	0.015
RMSE Z	0.017
GPS Method	Keynet VRS

PHOTOS:





Point ID	TW9
Project No.	26236
Project Name	DELAWARE VALLEY LiDAR
State	Pennsylvania
County	Bucks
Quad	Ambler

Aerial Target	
LiDAR Ground Control	
X LiDAR QC Point	
New Control	
Photo ID	
Published Control	

Coordinate System	
NAD83(2011)	
UTM – Zone 18N	
NAVD88	
GEOID12A	
Meters	

<b>Northing</b>	<b>Easting</b>	<b>Elevation</b>
4453127.795	488418.449	70.437

Operator	Kevin Chapman
Receiver Model	Trimble R-8, Model 3
Receiver S/N	5106461067
Antenna Height	2.000 Meters

Date (MM-DD-YYYY)	04/23/2015
RMSE Hz	0.013
RMSE Z	0.013
GPS Method	Keynet VRS

PHOTOS:





Point ID	TW11
Project No.	26236
Project Name	DELAWARE VALLEY LiDAR
State	Pennsylvania
County	Delaware
Quad	Marcus Hook

Aerial Target	
LiDAR Ground Control	
X LiDAR QC Point	
New Control	
Photo ID	
Published Control	

Coordinate System	
NAD83(2011)	
UTM – Zone 18N	
NAVD88	
GEOID12A	
Meters	

<b>Northing</b>	<b>Easting</b>	<b>Elevation</b>
4411283.694	459813.053	69.895

Operator	Kevin Chapman
Receiver Model	Trimble R-8, Model 3
Receiver S/N	5106461067
Antenna Height	2.000 Meters

Date (MM-DD-YYYY)	05/07/2015
RMSE Hz	0.007
RMSE Z	0.010
GPS Method	Keynet VRS

PHOTOS:





Point ID	TW13
Project No.	26236
Project Name	DELAWARE VALLEY LiDAR
State	Pennsylvania
County	Philadelphia
Quad	Germantown

	Aerial Target
	LiDAR Ground Control
X	LiDAR QC Point
	New Control
	Photo ID
	Published Control

Coordinate System
NAD83(2011)
UTM – Zone 18N
NAVD88
GEOID12A
Meters

Northing	Easting	Elevation
4428557.836	482748.175	31.882

Operator	Kevin Chapman
Receiver Model	Trimble R-8, Model 3
Receiver S/N	5106461067
Antenna Height	2.000 Meters

Date (MM-DD-YYYY)	05/07/2015
RMSE Hz	0.008
RMSE Z	0.010
GPS Method	Keynet VRS

PHOTOS:





Point ID	TW14
Project No.	26236
Project Name	DELAWARE VALLEY LiDAR
State	Pennsylvania
County	Montgomery
Quad	Germantown

Aerial Target	
LiDAR Ground Control	
X LiDAR QC Point	
New Control	
Photo ID	
Published Control	

Coordinate System	NAD83(2011)
	UTM – Zone 18N
	NAVD88
	GEOID12A
	Meters

Northing	Easting	Elevation
4436519.713	486276.940	99.431

Operator	Kevin Chapman
Receiver Model	Trimble R-8, Model 3
Receiver S/N	5106461067
Antenna Height	2.000 Meters

Date (MM-DD-YYYY)	04/23/2015
RMSE Hz	0.014
RMSE Z	0.014
GPS Method	Keynet VRS

PHOTOS:





Point ID	TW15
Project No.	26236
Project Name	DELAWARE VALLEY LiDAR
State	Pennsylvania
County	Bucks
Quad	Langhorne

Aerial Target	
LiDAR Ground Control	
X LiDAR QC Point	
New Control	
Photo ID	
Published Control	

Coordinate System	NAD83(2011)
	UTM – Zone 18N
	NAVD88
	GEOID12A
	Meters

Northing	Easting	Elevation
4452704.230	503222.820	35.045

Operator	Kevin Chapman
Receiver Model	Trimble R-8, Model 3
Receiver S/N	5106461067
Antenna Height	2.000 Meters

Date (MM-DD-YYYY)	04/26/2015
RMSE Hz	0.014
RMSE Z	0.013
GPS Method	Keynet VRS

PHOTOS:





Point ID	TW17
Project No.	26236
Project Name	DVRPC/NJ LIDAR
State	NEW JERSEY
County	BURLINGTON
Quad	ALLENTOWN

	Aerial Target
	LiDAR Ground Control
X	LiDAR QC Point
	New Control
	Photo ID
	Published Control

Coordinate System
NAD83(2011)
UTM – Zone 18N
NAVD88
GEOID12A
Meters

Northing	Easting	Elevation
4454892.531	536237.071	31.448

Operator	STEVE MILLER
Receiver Model	Trimble R-8, Model 3
Receiver S/N	5135472526
Antenna Height	2.000 Meters

Date (MM-DD-YYYY)	06/15/2015
RMSE Hz	0.014
RMSE Z	0.014
GPS Method	RTK

PHOTOS:





Point ID	TW18
Project No.	26236
Project Name	DVRPC/NJ LIDAR
State	NEW JERSEY
County	BURLINGTON
Quad	TREBTON EAST

Aerial Target	
LiDAR Ground Control	
X LiDAR QC Point	
New Control	
Photo ID	
Published Control	

Coordinate System	NAD83(2011)
	UTM – Zone 18N
	NAVD88
	GEOID12A
	Meters

Northing	Easting	Elevation
4449381.488	523923.983	19.343

Operator	STEVE MILLER
Receiver Model	Trimble R-8, Model 3
Receiver S/N	5135472526
Antenna Height	2.000 Meters

Date (MM-DD-YYYY)	06/15/2015
RMSE Hz	0.010
RMSE Z	0.011
GPS Method	RTK

PHOTOS:







Point ID	TW19
Project No.	26236
Project Name	DVRPC/NJ LIDAR
State	NEW JERSEY
County	BURLINGTON
Quad	BEVERLY

Aerial Target	
LiDAR Ground Control	
X LiDAR QC Point	
New Control	
Photo ID	
Published Control	

Coordinate System	NAD83(2011)
	UTM – Zone 18N
	NAVD88
	GEOID12A
	Meters

Northing	Easting	Elevation
4435674.051	510144.652	3.202

Operator	STEVE MILLER
Receiver Model	Trimble R-8, Model 3
Receiver S/N	5135472526
Antenna Height	2.000 Meters

Date (MM-DD-YYYY)	06/06/2015
RMSE Hz	0.014
RMSE Z	0.015
GPS Method	RTK

PHOTOS:





Point ID	TW21
Project No.	26236
Project Name	DVRPC/NJ LIDAR
State	NEW JERSEY
County	GLOUCESTER
Quad	WOODBURY

Aerial Target	
LiDAR Ground Control	
X LiDAR QC Point	
New Control	
Photo ID	
Published Control	

Coordinate System	NAD83(2011)
	UTM – Zone 18N
	NAVD88
	GEOID12A
	Meters

Northing	Easting	Elevation
4411403.422	485100.305	2.406

Operator	STEVE MILLER
Receiver Model	Trimble R-8, Model 3
Receiver S/N	5135472526
Antenna Height	2.000 Meters

Date (MM-DD-YYYY)	06/03/2015
RMSE Hz	0.007
RMSE Z	0.008
GPS Method	RTK

PHOTOS:





Point ID	TW22
Project No.	26236
Project Name	DVRPC/NJ LIDAR
State	NEW JERSEY
County	GLOUCESTER
Quad	BRIDGEPORT

Aerial Target	
LiDAR Ground Control	
X LiDAR QC Point	
New Control	
Photo ID	
Published Control	

Coordinate System	NAD83(2011)
	UTM – Zone 18N
	NAVD88
	GEOID12A
	Meters

Northing	Easting	Elevation
4401995.831	468814.531	4.853

Operator	STEVE MILLER
Receiver Model	Trimble R-8, Model 3
Receiver S/N	5135472526
Antenna Height	2.000 Meters

Date (MM-DD-YYYY)	06/03/2015
RMSE Hz	0.007
RMSE Z	0.008
GPS Method	RTK

PHOTOS:





Point ID	TW23
Project No.	26236
Project Name	DELAWARE VALLEY
State	NEW JERSEY
County	GLOUCESTER
Quad	PITTMAN WEST

Aerial Target	
LiDAR Ground Control	
X LiDAR QC Point	
New Control	
Photo ID	
Published Control	

Coordinate System	NAD83(2011)
	UTM – Zone 18N
	NAVD88
	GEOID12A
	Meters

<b>Northing</b>	<b>Easting</b>	<b>Elevation</b>
4398038.663	487152.110	40.738

Operator	STEVE MILLER
Receiver Model	Trimble R-8, Model 3
Receiver S/N	5133470976
Antenna Height	2.000 Meters

Date (MM-DD-YYYY)	06/03/2015
RMSE Hz	0.006
RMSE Z	0.008
GPS Method	RTK

PHOTOS:





Point ID	TW24
Project No.	26236
Project Name	DVRPC/NJ LIDAR
State	NEW JERSEY
County	CAMDEN
Quad	CLEMENTON

Aerial Target	
LiDAR Ground Control	
X LiDAR QC Point	
New Control	
Photo ID	
Published Control	

Coordinate System	NAD83(2011)
	UTM – Zone 18N
	NAVD88
	GEOID12A
	Meters

<b>Northing</b>	<b>Easting</b>	<b>Elevation</b>
4412367.271	504626.680	46.431

Operator	STEVE MILLER
Receiver Model	Trimble R-8, Model 3
Receiver S/N	5135472526
Antenna Height	2.000 Meters

Date (MM-DD-YYYY)	06/05/2015
RMSE Hz	0.013
RMSE Z	0.014
GPS Method	RTK

PHOTOS:





Point ID	TW25
Project No.	26236
Project Name	DVRPC/NJ LIDAR
State	NEW JERSEY
County	BURLINGTON
Quad	MT. HOLLY

Aerial Target	
LiDAR Ground Control	
X LiDAR QC Point	
New Control	
Photo ID	
Published Control	

Coordinate System	NAD83(2011)
	UTM – Zone 18N
	NAVD88
	GEOID12A
	Meters

Northing	Easting	Elevation
4423056.246	516234.229	12.769

Operator	STEVE MILLER
Receiver Model	Trimble R-8, Model 3
Receiver S/N	5135472526
Antenna Height	2.000 Meters

Date (MM-DD-YYYY)	06/06/2015
RMSE Hz	0.013
RMSE Z	0.013
GPS Method	RTK

PHOTOS:





Point ID	TW26
Project No.	26236
Project Name	DELAWARE VALLEY LiDAR
State	New Jersey
County	Burlington
Quad	New Egypt

Aerial Target	
LiDAR Ground Control	
X LiDAR QC Point	
New Control	
Photo ID	
Published Control	

Coordinate System	
NAD83(2011)	
UTM – Zone 18N	
NAVD88	
GEOID12A	
Meters	

Northing	Easting	Elevation
4439972.584	532528.321	29.415

Operator	Kevin Chapman
Receiver Model	Trimble R-8, Model 3
Receiver S/N	5106461067
Antenna Height	2.000 Meters

Date (MM-DD-YYYY)	06/13/2015
RMSE Hz	0.01
RMSE Z	0.011
GPS Method	Keynet VRS

PHOTOS:





Point ID	TW28
Project No.	26236
Project Name	DVRPC/NJ LIDAR
State	NEW JERSEY
County	BURLINGTON
Quad	MEDFORD LAKES

Aerial Target	
LiDAR Ground Control	
X LiDAR QC Point	
New Control	
Photo ID	
Published Control	

Coordinate System	NAD83(2011)
	UTM – Zone 18N
	NAVD88
	GEOID12A
	Meters

Northing	Easting	Elevation
4407530.252	519883.755	31.676

Operator	STEVE MILLER
Receiver Model	Trimble R-8, Model 3
Receiver S/N	5135472526
Antenna Height	2.000 Meters

Date (MM-DD-YYYY)	06/14/2015
RMSE Hz	0.014
RMSE Z	0.014
GPS Method	RTK

PHOTOS:







Point ID	TW29
Project No.	26236
Project Name	DVRPC/NJ LIDAR
State	NEW JERSEY
County	GLOUCESTER
Quad	MEDFORD LAKES

Aerial Target	
LiDAR Ground Control	
X LiDAR QC Point	
New Control	
Photo ID	
Published Control	

Coordinate System	NAD83(2011)
	UTM – Zone 18N
	NAVD88
	GEOID12A
	Meters

Northing	Easting	Elevation
4402992.902	514932.663	29.248

Operator	STEVE MILLER
Receiver Model	Trimble R-8, Model 3
Receiver S/N	5135472526
Antenna Height	2.000 Meters

Date (MM-DD-YYYY)	06/04/2015
RMSE Hz	0.013
RMSE Z	0.013
GPS Method	RTK

PHOTOS:





Point ID	TW31
Project No.	26236
Project Name	DVRPC/NJ LIDAR
State	NEW JERSEY
County	BURLINGTON
Quad	CHATSWORTH

Aerial Target	
LiDAR Ground Control	
X LiDAR QC Point	
New Control	
Photo ID	
Published Control	

Coordinate System	
NAD83(2011)	
UTM – Zone 18N	
NAVD88	
GEOID12A	
Meters	

Northing	Easting	Elevation
4407997.518	535312.527	34.212

Operator	STEVE MILLER
Receiver Model	Trimble R-8, Model 3
Receiver S/N	513572526
Antenna Height	2.000 Meters

Date (MM-DD-YYYY)	06/14/2015
RMSE Hz	0.013
RMSE Z	0.016
GPS Method	RTK

PHOTOS:





Point ID	TW32
Project No.	26236
Project Name	DELAWARE VALLEY LiDAR
State	New Jersey
County	Burlington
Quad	Woodmansie

	Aerial Target
	LiDAR Ground Control
X	LiDAR QC Point
	New Control
	Photo ID
	Published Control

Coordinate System
NAD83(2011)
UTM – Zone 18N
NAVD88
GEOID12A
Meters

Northing	Easting	Elevation
4407709.793	549328.226	58.349

Operator	Kevin Chapman
Receiver Model	Trimble R-8, Model 3
Receiver S/N	5106461067
Antenna Height	2.000 Meters

Date (MM-DD-YYYY)	06/12/2015
RMSE Hz	0.014
RMSE Z	0.015
GPS Method	Keynet VRS

PHOTOS:





Point ID	TW33
Project No.	26236
Project Name	DVRPC/NJ LIDAR
State	NEW JERSEY
County	BURLINGTON
Quad	JENKINS

Aerial Target	
LiDAR Ground Control	
X LiDAR QC Point	
New Control	
Photo ID	
Published Control	

Coordinate System	NAD83(2011)
	UTM – Zone 18N
	NAVD88
	GEOID12A
	Meters

Northing	Easting	Elevation
4399651.701	540309.144	17.219

Operator	STEVE MILLER
Receiver Model	Trimble R-8, Model 3
Receiver S/N	5135472526
Antenna Height	2.000 Meters

Date (MM-DD-YYYY)	06/13/2015
RMSE Hz	0.015
RMSE Z	0.016
GPS Method	RTK

PHOTOS:





Point ID	TW35
Project No.	26236
Project Name	DVRPC/NJ LIDAR
State	NEW JERSEY
County	BURLINGTON
Quad	NEW GREтна

	Aerial Target
	LiDAR Ground Control
X	LiDAR QC Point
	New Control
	Photo ID
	Published Control

Coordinate System
NAD83(2011)
UTM – Zone 18N
NAVD88
GEOID12A
Meters

Northing	Easting	Elevation
4386258.156	545712.700	9.451

Operator	STEVE MILLER
Receiver Model	Trimble R-8, Model 3
Receiver S/N	5135472526
Antenna Height	2.000 Meters

Date (MM-DD-YYYY)	06/12/2015
RMSE Hz	0.013
RMSE Z	0.019
GPS Method	RTK

PHOTOS:





Point ID	TW35
Project No.	26236
Project Name	DVRPC/NJ LIDAR
State	NEW JERSEY
County	BURLINGTON
Quad	NEW GREтна

Aerial Target	
LiDAR Ground Control	
X LiDAR QC Point	
New Control	
Photo ID	
Published Control	

Coordinate System	
NAD83(2011)	
UTM – Zone 18N	
NAVD88	
GEOID12A	
Meters	

<b>Northing</b>	<b>Easting</b>	<b>Elevation</b>
4386258.150	545712.700	9.439

Operator	STEVE MILLER
Receiver Model	Trimble R-8, Model 3
Receiver S/N	5135472526
Antenna Height	2.000 Meters

Date (MM-DD-YYYY)	06/12/2015
RMSE Hz	N/A
RMSE Z	N/A
GPS Method	RTK

PHOTOS:





Point ID	TW51
Project No.	26236
Project Name	DVRPC/NJ LIDAR
State	NEW JERSEY
County	GLOUCESTER
Quad	NEWFIELD

Aerial Target	
LiDAR Ground Control	
X LiDAR QC Point	
New Control	
Photo ID	
Published Control	

Coordinate System	NAD83(2011)
	UTM – Zone 18N
	NAVD88
	GEOID12A
	Meters

Northing	Easting	Elevation
4385432.086	492920.672	32.314

Operator	STEVE MILLER
Receiver Model	Trimble R-8, Model 3
Receiver S/N	5135472526
Antenna Height	2.000 Meters

Date (MM-DD-YYYY)	06/03/2015
RMSE Hz	0.014
RMSE Z	0.014
GPS Method	RTK

PHOTOS:





Point ID	TW52
Project No.	26236
Project Name	DVRPC/NJ LIDAR
State	NEW JERSEY
County	GLOUCESTER
Quad	PITTMAN WEST

Aerial Target	
LiDAR Ground Control	
X LiDAR QC Point	
New Control	
Photo ID	
Published Control	

Coordinate System	NAD83(2011)
	UTM – Zone 18N
	NAVD88
	GEOID12A
	Meters

Northing	Easting	Elevation
4388750.495	488297.344	41.194

Operator	STEVE MILLER
Receiver Model	Trimble R-8, Model 3
Receiver S/N	5135472526
Antenna Height	2.000 Meters

Date (MM-DD-YYYY)	06/03/2015
RMSE Hz	0.013
RMSE Z	0.013
GPS Method	RTK

PHOTOS:







Point ID	TW53
Project No.	26236
Project Name	DVRPC/NJ LIDAR
State	NEW JERSEY
County	GLOUCESTER
Quad	WILLIAMSTOWN

Aerial Target	
LiDAR Ground Control	
X LiDAR QC Point	
New Control	
Photo ID	
Published Control	

Coordinate System	
NAD83(2011)	
UTM – Zone 18N	
NAVD88	
GEOID12A	
Meters	

Northing	Easting	Elevation
4389522.024	501052.507	39.693

Operator	STEVE MILLER
Receiver Model	Trimble R-8, Model 3
Receiver S/N	5135472526
Antenna Height	2.000 Meters

Date (MM-DD-YYYY)	06/04/2015
RMSE Hz	0.013
RMSE Z	0.013
GPS Method	RTK

PHOTOS:





Point ID	TW55
Project No.	26236
Project Name	DVRPC/NJ LIDAR
State	NEW JERSEY
County	GLOUCESTER
Quad	WILLIAMSTOWN

	Aerial Target
	LiDAR Ground Control
X	LiDAR QC Point
	New Control
	Photo ID
	Published Control

Coordinate System
NAD83(2011)
UTM – Zone 18N
NAVD88
GEOID12A
Meters

Northing	Easting	Elevation
4400337.781	501462.857	44.409

Operator	STEVE MILLER
Receiver Model	Trimble R-8, Model 3
Receiver S/N	5135472526
Antenna Height	2.000 Meters

Date (MM-DD-YYYY)	06/04/2015
RMSE Hz	0.013
RMSE Z	0.014
GPS Method	RTK

PHOTOS:





Point ID	TW57
Project No.	26236
Project Name	DVRPC/NJ LIDAR
State	NEW JERSEY
County	BURLINGTON
Quad	MOORESTOWN

	Aerial Target
	LiDAR Ground Control
X	LiDAR QC Point
	New Control
	Photo ID
	Published Control

Coordinate System
NAD83(2011)
UTM – Zone 18N
NAVD88
GEOID12A
Meters

Northing	Easting	Elevation
4424874.739	508912.191	12.570

Operator	STEVE MILLER
Receiver Model	Trimble R-8, Model 3
Receiver S/N	5135472526
Antenna Height	2.000 Meters

Date (MM-DD-YYYY)	06/05/2015
RMSE Hz	0.013
RMSE Z	0.013
GPS Method	RTK

PHOTOS:





Point ID	TW58
Project No.	26236
Project Name	DVRPC/NJ LIDAR
State	NEW JERSEY
County	BURLINGTON
Quad	PEMBERTON

Aerial Target	
LiDAR Ground Control	
X LiDAR QC Point	
New Control	
Photo ID	
Published Control	

Coordinate System	
NAD83(2011)	
UTM – Zone 18N	
NAVD88	
GEOID12A	
Meters	

<b>Northing</b>	<b>Easting</b>	<b>Elevation</b>
4428125.849	521367.142	22.435

Operator	STEVE MILLER
Receiver Model	Trimble R-8, Model 3
Receiver S/N	5135472526
Antenna Height	2.000 Meters

Date (MM-DD-YYYY)	06/06/2015
RMSE Hz	0.014
RMSE Z	0.018
GPS Method	RTK

PHOTOS:





Point ID	TW101
Project No.	26236
Project Name	DVRPC/NJ LIDAR
State	NEW JERSEY
County	BURLINGTON
Quad	JCHATSWORTH

Aerial Target	
LiDAR Ground Control	
X LiDAR QC Point	
New Control	
Photo ID	
Published Control	

Coordinate System	
NAD83(2011)	
UTM – Zone 18N	
NAVD88	
GEOID12A	
Meters	

Northing	Easting	Elevation
4400169.252	535578.534	18.634

Operator	STEVE MILLER
Receiver Model	Trimble R-8, Model 3
Receiver S/N	5135472526
Antenna Height	2.000 Meters

Date (MM-DD-YYYY)	06/13/2015
RMSE Hz	0.016
RMSE Z	0.016
GPS Method	RTK

PHOTOS:

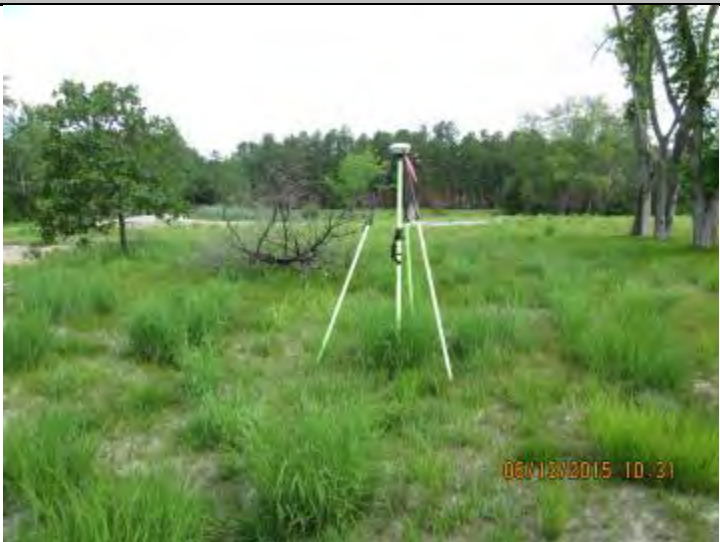



Point ID	TW102
Project No.	26236
Project Name	DVRPC/NJ LIDAR
State	NEW JERSEY
County	BURLINGTON
Quad	WOODMANSIE

	Aerial Target
	LiDAR Ground Control
X	LiDAR QC Point
	New Control
	Photo ID
	Published Control

Coordinate System	
NAD83(2011)	
UTM – Zone 18N	
NAVD88	
GEOID12A	
Meters	

<b>Northing</b>	<b>Easting</b>	<b>Elevation</b>
4401575.919	551191.053	28.844

Operator	STEVE MILLER
Receiver Model	Trimble R-8, Model 3
Receiver S/N	5135472526
Antenna Height	2.000 Meters

Date (MM-DD-YYYY)	06/13/2015
RMSE Hz	0.014
RMSE Z	0.016
GPS Method	RTK

PHOTOS:





Point ID	TW103
Project No.	26236
Project Name	DVRPC/NJ LIDAR
State	NEW JERSEY
County	BURLINGTON
Quad	MEDFORD LAKES

Aerial Target	
LiDAR Ground Control	
X LiDAR QC Point	
New Control	
Photo ID	
Published Control	

Coordinate System	NAD83(2011)
	UTM – Zone 18N
	NAVD88
	GEOID12A
	Meters

Northing	Easting	Elevation
4404580.143	521043.513	25.054

Operator	STEVE MILLER
Receiver Model	Trimble R-8, Model 3
Receiver S/N	5135472526
Antenna Height	2.000 Meters

Date (MM-DD-YYYY)	06/14/2015
RMSE Hz	0.013
RMSE Z	0.013
GPS Method	RTK

PHOTOS:





## **HORIZONTAL CHECK POINT DATA SHEETS**





Point ID	PP1
Project No.	26236
Project Name	DVRPC/NJ LIDAR
State	NEW JERSEY
County	GLOUCESTER
Quad	PITMAN WEST

Aerial Target	
LiDAR Ground Control	
LiDAR QC Point	
New Control	
X Photo ID	
Published Control	

Coordinate System	NAD83(2011)
	UTM – Zone 18N
	NAVD88
	GEOID12A
	Meters

Northing	Easting	Elevation
4398178.150	487277.559	Hz Only

Operator	STEVE MILLER
Receiver Model	Trimble R-8, Model 3
Receiver S/N	5135472526
Antenna Height	2.000 Meters

Date (MM-DD-YYYY)	06/02/2015
RMSE Hz	0.013
RMSE Z	N/A
GPS Method	RTK

PHOTOS:





Point ID	PP2
Project No.	26236
Project Name	DVRPC/NJ LIDAR
State	NEW JERSEY
County	GLOUCESTER
Quad	WOODSTOWN

	Aerial Target
	LiDAR Ground Control
	LiDAR QC Point
	New Control
X	Photo ID
	Published Control

Coordinate System	NAD83(2011)
	UTM – Zone 18N
	NAVD88
	GEOID12A
	Meters

<b>Northing</b>	<b>Easting</b>	<b>Elevation</b>
4396873.911	477855.223	Hz Only

Operator	STEVE MILLER
Receiver Model	Trimble R-8, Model 3
Receiver S/N	5135472526
Antenna Height	2.000 Meters

Date (MM-DD-YYYY)	06/02/2015
RMSE Hz	0.011
RMSE Z	N/A
GPS Method	RTK

PHOTOS:





Point ID	PP3
Project No.	26236
Project Name	DVRPC/NJ LIDAR
State	NEW JERSEY
County	GLOUCESTER
Quad	BRIDGEPORT

	Aerial Target
	LiDAR Ground Control
	LiDAR QC Point
	New Control
X	Photo ID
	Published Control

Coordinate System	NAD83(2011)
	UTM – Zone 18N
	NAVD88
	GEOID12A
	Meters

Northing	Easting	Elevation
4402008.453	468821.339	Hz Only

Operator	STEVE MILLER
Receiver Model	Trimble R-8, Model 3
Receiver S/N	5135472526
Antenna Height	2.000 Meters

Date (MM-DD-YYYY)	06/03/2015
RMSE Hz	0.014
RMSE Z	N/A
GPS Method	RTK

PHOTOS:





Point ID	PP4
Project No.	26236
Project Name	DVRPC/NJ LIDAR
State	NEW JERSEY
County	GLOUCESTER
Quad	BRIDGEPORT

Aerial Target	
LiDAR Ground Control	
LiDAR QC Point	
New Control	
X Photo ID	
Published Control	

Coordinate System	NAD83(2011)
	UTM – Zone 18N
	NAVD88
	GEOID12A
	Meters

<b>Northing</b>	<b>Easting</b>	<b>Elevation</b>
4408338.955	475052.910	Hz Only

Operator	STEVE MILLER
Receiver Model	Trimble R-8, Model 3
Receiver S/N	5135472526
Antenna Height	2.000 Meters

Date (MM-DD-YYYY)	06/03/2015
RMSE Hz	0.013
RMSE Z	N/A
GPS Method	RTK

PHOTOS:





Point ID	PP5
Project No.	26236
Project Name	DVRPC/NJ LIDAR
State	NEW JERSEY
County	GLOUCESTER
Quad	WOODBURY

	Aerial Target
	LiDAR Ground Control
	LiDAR QC Point
	New Control
X	Photo ID
	Published Control

Coordinate System	
NAD83(2011)	
UTM – Zone 18N	
NAVD88	
GEOID12A	
Meters	

<b>Northing</b>	<b>Easting</b>	<b>Elevation</b>
4410968.922	484706.676	Hz Only

Operator	STEVE MILLER
Receiver Model	Trimble R-8, Model 3
Receiver S/N	5135472526
Antenna Height	2.000 Meters

Date (MM-DD-YYYY)	06/03/2015
RMSE Hz	0.013
RMSE Z	N/A
GPS Method	RTK

PHOTOS:





Point ID	PP6
Project No.	26236
Project Name	DVRPC/NJ LIDAR
State	NEW JERSEY
County	GLOUCESTER
Quad	RUNNEMEDE

	Aerial Target
	LiDAR Ground Control
	LiDAR QC Point
	New Control
X	Photo ID
	Published Control

Coordinate System
NAD83(2011)
UTM – Zone 18N
NAVD88
GEOID12A
Meters

Northing	Easting	Elevation
4405968.887	489378.535	Hz Only

Operator	STEVE MILLER
Receiver Model	Trimble R-8, Model 3
Receiver S/N	5135472526
Antenna Height	2.000 Meters

Date (MM-DD-YYYY)	06/03/2015
RMSE Hz	0.015
RMSE Z	N/A
GPS Method	RTK

PHOTOS:





Point ID	PP7
Project No.	26236
Project Name	DVRPC/NJ LIDAR
State	NEW JERSEY
County	GLOUCESTER
Quad	RUNNEMEDE

Aerial Target	
LiDAR Ground Control	
LiDAR QC Point	
New Control	
X Photo ID	
Published Control	

Coordinate System	NAD83(2011)
	UTM – Zone 18N
	NAVD88
	GEOID12A
	Meters

<b>Northing</b>	<b>Easting</b>	<b>Elevation</b>
4401357.385	486275.508	Hz Only

Operator	STEVE MILLER
Receiver Model	Trimble R-8, Model 3
Receiver S/N	5135472526
Antenna Height	2.000 Meters

Date (MM-DD-YYYY)	06/03/2015
RMSE Hz	0.013
RMSE Z	N/A
GPS Method	STATIC/RTK

PHOTOS:





Point ID	PP8
Project No.	26236
Project Name	DVRPC/NJ LIDAR
State	NEW JERSEY
County	GLOUCESTER
Quad	PITTMAN EAST

Aerial Target	
LiDAR Ground Control	
LiDAR QC Point	
New Control	
X Photo ID	
Published Control	

Coordinate System	NAD83(2011)
	UTM – Zone 18N
	NAVD88
	GEOID12A
	Meters

Northing	Easting	Elevation
4395660.291	493910.114	Hz Only

Operator	STEVE MILLER
Receiver Model	Trimble R-8, Model 3
Receiver S/N	5135472526
Antenna Height	2.000 Meters

Date (MM-DD-YYYY)	06/03/2015
RMSE Hz	0.013
RMSE Z	N/A
GPS Method	RTK

PHOTOS:







Point ID	PP9
Project No.	26236
Project Name	DVRPC/NJ LIDAR
State	NEW JERSEY
County	GLOUCESTER
Quad	NEWFIELD

	Aerial Target
	LiDAR Ground Control
	LiDAR QC Point
	New Control
X	Photo ID
	Published Control

Coordinate System	NAD83(2011)
	UTM – Zone 18N
	NAVD88
	GEOID12A
	Meters

Northing	Easting	Elevation
4385380.533	493061.128	Hz Only

Operator	STEVE MILLER
Receiver Model	Trimble R-8, Model 3
Receiver S/N	5135472526
Antenna Height	2.000 Meters

Date (MM-DD-YYYY)	06/03/2015
RMSE Hz	0.014
RMSE Z	N/A
GPS Method	RTK

PHOTOS:





Point ID	PP10
Project No.	26236
Project Name	DVRPC/NJ LIDAR
State	NEW JERSEY
County	GLOUCESTER
Quad	PITTMAN WEST

Aerial Target	
LiDAR Ground Control	
LiDAR QC Point	
New Control	
X Photo ID	
Published Control	

Coordinate System	NAD83(2011)
	UTM – Zone 18N
	NAVD88
	GEOID12A
	Meters

<b>Northing</b>	<b>Easting</b>	<b>Elevation</b>
4388744.505	488318.966	Hz Only

Operator	STEVE MILLER
Receiver Model	Trimble R-8, Model 3
Receiver S/N	5135472526
Antenna Height	2.000 Meters

Date (MM-DD-YYYY)	06/03/2015
RMSE Hz	0.013
RMSE Z	N/A
GPS Method	RTK

PHOTOS:





Point ID	PP11
Project No.	26236
Project Name	DVRPC/NJ LIDAR
State	NEW JERSEY
County	GLOUCESTER
Quad	NEWFIELD

Aerial Target	
LiDAR Ground Control	
LiDAR QC Point	
New Control	
X Photo ID	
Published Control	

Coordinate System	NAD83(2011)
	UTM – Zone 18N
	NAVD88
	GEOID12A
	Meters

Northing	Easting	Elevation
4380979.961	495848.125	Hz Only

Operator	STEVE MILLER
Receiver Model	Trimble R-8, Model 3
Receiver S/N	5135472526
Antenna Height	2.000 Meters

Date (MM-DD-YYYY)	06/04/2015
RMSE Hz	0.013
RMSE Z	N/A
GPS Method	RTK

PHOTOS:





Point ID	PP12
Project No.	26236
Project Name	DVRPC/NJ LIDAR
State	NEW JERSEY
County	GLOUCESTER
Quad	PITTMAN WEST

Aerial Target	
LiDAR Ground Control	
LiDAR QC Point	
New Control	
X Photo ID	
Published Control	

Coordinate System	NAD83(2011)
	UTM – Zone 18N
	NAVD88
	GEOID12A
	Meters

Northing	Easting	Elevation
4392010.572	482601.648	Hz Only

Operator	STEVE MILLER
Receiver Model	Trimble R-8, Model 3
Receiver S/N	5135472526
Antenna Height	2.000 Meters

Date (MM-DD-YYYY)	06/03/2015
RMSE Hz	0.013
RMSE Z	N/A
GPS Method	RTK/STATIC

PHOTOS:





Point ID	PP13
Project No.	26236
Project Name	DVRPC/NJ LIDAR
State	NEW JERSEY
County	GLOUCESTER
Quad	BUENA

Aerial Target	
LiDAR Ground Control	
LiDAR QC Point	
New Control	
X Photo ID	
Published Control	

Coordinate System	NAD83(2011)
	UTM – Zone 18N
	NAVD88
	GEOID12A
	Meters

<b>Northing</b>	<b>Easting</b>	<b>Elevation</b>
4378279.957	500162.888	Hz Only

Operator	STEVE MILLER
Receiver Model	Trimble R-8, Model 3
Receiver S/N	5135472526
Antenna Height	2.000 Meters

Date (MM-DD-YYYY)	06/04/2015
RMSE Hz	0.013
RMSE Z	N/A
GPS Method	RTK

PHOTOS:





Point ID	PP14
Project No.	26236
Project Name	DVRPC/NJ LIDAR
State	NEW JERSEY
County	GLOUCESTER
Quad	WILLIAMSTOWN

Aerial Target	
LiDAR Ground Control	
LiDAR QC Point	
New Control	
X Photo ID	
Published Control	

Coordinate System	NAD83(2011)
	UTM – Zone 18N
	NAVD88
	GEOID12A
	Meters

Northing	Easting	Elevation
4378279.957	500162.888	Hz Only

Operator	STEVE MILLER
Receiver Model	Trimble R-8, Model 3
Receiver S/N	5135472526
Antenna Height	2.000 Meters

Date (MM-DD-YYYY)	06/04/2015
RMSE Hz	0.013
RMSE Z	N/A
GPS Method	RTK

PHOTOS:





Point ID	PP15
Project No.	26236
Project Name	DVRPC/NJ LIDAR
State	NEW JERSEY
County	GLOUCESTER
Quad	WILLIAMSTOWN

Aerial Target	
LiDAR Ground Control	
LiDAR QC Point	
New Control	
X Photo ID	
Published Control	

Coordinate System	NAD83(2011)
	UTM – Zone 18N
	NAVD88
	GEOID12A
	Meters

<b>Northing</b>	<b>Easting</b>	<b>Elevation</b>
4395979.422	506757.865	Hz Only

Operator	STEVE MILLER
Receiver Model	Trimble R-8, Model 3
Receiver S/N	5135472526
Antenna Height	2.000 Meters

Date (MM-DD-YYYY)	06/04/2015
RMSE Hz	0.012
RMSE Z	N/A
GPS Method	RTK

PHOTOS:





Point ID	PP16
Project No.	26236
Project Name	DVRPC/NJ LIDAR
State	NEW JERSEY
County	GLOUCESTER
Quad	HAMMONTOWN

Aerial Target	
LiDAR Ground Control	
X LiDAR QC Point	
New Control	
Photo ID	
Published Control	

Coordinate System	NAD83(2011)
	UTM – Zone 18N
	NAVD88
	GEOID12A
	Meters

<b>Northing</b>	<b>Easting</b>	<b>Elevation</b>
4393482.261	513225.082	Hz Only

Operator	STEVE MILLER
Receiver Model	Trimble R-8, Model 3
Receiver S/N	5108461884
Antenna Height	2.000 Meters

Date (MM-DD-YYYY)	06/04/2015
RMSE Hz	0.013
RMSE Z	N/A
GPS Method	RTK

PHOTOS:







Point ID	PP17
Project No.	26236
Project Name	DVRPC/NJ LIDAR
State	NEW JERSEY
County	GLOUCESTER
Quad	MEDFORD LAKES

Aerial Target	
LiDAR Ground Control	
LiDAR QC Point	
New Control	
X Photo ID	
Published Control	

Coordinate System	NAD83(2011)
	UTM – Zone 18N
	NAVD88
	GEOID12A
	Meters

<b>Northing</b>	<b>Easting</b>	<b>Elevation</b>
4402738.099	514442.960	Hz Only

Operator	STEVE MILLER
Receiver Model	Trimble R-8, Model 3
Receiver S/N	5135472526
Antenna Height	2.000 Meters

Date (MM-DD-YYYY)	06/04/2015
RMSE Hz	0.013
RMSE Z	N/A
GPS Method	RTK

PHOTOS:





Point ID	PP18
Project No.	26236
Project Name	DVRPC/NJ LIDAR
State	NEW JERSEY
County	CAMDEN
Quad	CAMDEN

	Aerial Target
	LiDAR Ground Control
	LiDAR QC Point
	New Control
X	Photo ID
	Published Control

Coordinate System
NAD83(2011)
UTM – Zone 18N
NAVD88
GEOID12A
Meters

Northing	Easting	Elevation
4419033.829	491989.664	Hz Only

Operator	STEVE MILLER
Receiver Model	Trimble R-8, Model 3
Receiver S/N	5135472526
Antenna Height	2.000 Meters

Date (MM-DD-YYYY)	06/05/2015
RMSE Hz	0.011
RMSE Z	N/A
GPS Method	RTK

PHOTOS:





Point ID	PP19
Project No.	26236
Project Name	DVRPC/NJ LIDAR
State	NEW JERSEY
County	CAMDEN
Quad	RUNNEMEDE

	Aerial Target
	LiDAR Ground Control
	LiDAR QC Point
	New Control
X	Photo ID
	Published Control

Coordinate System	NAD83(2011)
	UTM – Zone 18N
	NAVD88
	GEOID12A
	Meters

<b>Northing</b>	<b>Easting</b>	<b>Elevation</b>
4406837.553	498644.005	Hz Only

Operator	STEVE MILLER
Receiver Model	Trimble R-8, Model 3
Receiver S/N	5135472526
Antenna Height	2.000 Meters

Date (MM-DD-YYYY)	06/05/2015
RMSE Hz	0.014
RMSE Z	N/A
GPS Method	RTK

PHOTOS:





Point ID	PP20
Project No.	26236
Project Name	DVRPC/NJ LIDAR
State	NEW JERSEY
County	CAMDEN
Quad	RUNNEMEDE

Aerial Target	
LiDAR Ground Control	
LiDAR QC Point	
New Control	
X Photo ID	
Published Control	

Coordinate System	NAD83(2011)
	UTM – Zone 18N
	NAVD88
	GEOID12A
	Meters

<b>Northing</b>	<b>Easting</b>	<b>Elevation</b>
4400302.722	501712.640	Hz Only

Operator	STEVE MILLER
Receiver Model	Trimble R-8, Model 3
Receiver S/N	5135472526
Antenna Height	2.000 Meters

Date (MM-DD-YYYY)	06/05/2015
RMSE Hz	0.013
RMSE Z	N/A
GPS Method	RTK

PHOTOS:





Point ID	PP21
Project No.	26236
Project Name	DVRPC/NJ LIDAR
State	NEW JERSEY
County	CAMDEN
Quad	CLEMENTON

Aerial Target	
LiDAR Ground Control	
LiDAR QC Point	
New Control	
X Photo ID	
Published Control	

Coordinate System	NAD83(2011)
	UTM – Zone 18N
	NAVD88
	GEOID12A
	Meters

<b>Northing</b>	<b>Easting</b>	<b>Elevation</b>
4402427.645	508497.297	Hz Only

Operator	STEVE MILLER
Receiver Model	Trimble R-8, Model 3
Receiver S/N	5135472526
Antenna Height	2.000 Meters

Date (MM-DD-YYYY)	06/05/2015
RMSE Hz	0.013
RMSE Z	N/A
GPS Method	RTK

PHOTOS:





Point ID	PP22
Project No.	26236
Project Name	DVRPC/NJ LIDAR
State	NEW JERSEY
County	BURLINGTON
Quad	MOORESTOWN

	Aerial Target
	LiDAR Ground Control
	LiDAR QC Point
	New Control
X	Photo ID
	Published Control

Coordinate System	
NAD83(2011)	
UTM – Zone 18N	
NAVD88	
GEOID12A	
Meters	

Northing	Easting	Elevation
4413077.760	504481.794	Hz Only

Operator	STEVE MILLER
Receiver Model	Trimble R-8, Model 3
Receiver S/N	5135472526
Antenna Height	2.000 Meters

Date (MM-DD-YYYY)	06/05/2015
RMSE Hz	0.013
RMSE Z	N/A
GPS Method	RTK

PHOTOS:





Point ID	PP23
Project No.	26236
Project Name	DVRPC/NJ LIDAR
State	NEW JERSEY
County	BURLINGTON
Quad	MOORESTOWN

	Aerial Target
	LiDAR Ground Control
	LiDAR QC Point
	New Control
X	Photo ID
	Published Control

Coordinate System
NAD83(2011)
UTM – Zone 18N
NAVD88
GEOID12A
Meters

Northing	Easting	Elevation
4419233.186	509483.429	Hz Only

Operator	STEVE MILLER
Receiver Model	Trimble R-8, Model 3
Receiver S/N	5135472526
Antenna Height	2.000 Meters

Date (MM-DD-YYYY)	06/05/2015
RMSE Hz	0.013
RMSE Z	N/A
GPS Method	RTK

PHOTOS:





Point ID	PP24
Project No.	26236
Project Name	DVRPC/NJ LIDAR
State	NEW JERSEY
County	BURLINGTON
Quad	MOORESTOWN

Aerial Target	
LiDAR Ground Control	
LiDAR QC Point	
New Control	
X Photo ID	
Published Control	

Coordinate System	NAD83(2011)
	UTM – Zone 18N
	NAVD88
	GEOID12A
	Meters

<b>Northing</b>	<b>Easting</b>	<b>Elevation</b>
4424886.642	508876.565	Hz Only

Operator	STEVE MILLER
Receiver Model	Trimble R-8, Model 3
Receiver S/N	5135472526
Antenna Height	2.000 Meters

Date (MM-DD-YYYY)	06/05/2015
RMSE Hz	0.013
RMSE Z	N/A
GPS Method	RTK

PHOTOS:







Point ID	PP25
Project No.	26236
Project Name	DVRPC/NJ LIDAR
State	NEW JERSEY
County	CAMDEN
Quad	CAMDEN

Aerial Target	
LiDAR Ground Control	
LiDAR QC Point	
New Control	
X Photo ID	
Published Control	

Coordinate System	NAD83(2011)
	UTM – Zone 18N
	NAVD88
	GEOID12A
	Meters

<b>Northing</b>	<b>Easting</b>	<b>Elevation</b>
4425063.658	497015.152	Hz Only

Operator	STEVE MILLER
Receiver Model	Trimble R-8, Model 3
Receiver S/N	5135472526
Antenna Height	2.000 Meters

Date (MM-DD-YYYY)	06/06/2015
RMSE Hz	0.013
RMSE Z	N/A
GPS Method	RTK

PHOTOS:





Point ID	PP26
Project No.	26236
Project Name	DVRPC/NJ LIDAR
State	NEW JERSEY
County	BURLINGTON
Quad	BEVERLY

Aerial Target	
LiDAR Ground Control	
LiDAR QC Point	
New Control	
X Photo ID	
Published Control	

Coordinate System	NAD83(2011)
	UTM – Zone 18N
	NAVD88
	GEOID12A
	Meters

<b>Northing</b>	<b>Easting</b>	<b>Elevation</b>
4431419.982	502529.886	Hz Only

Operator	STEVE MILLER
Receiver Model	Trimble R-8, Model 3
Receiver S/N	5135472526
Antenna Height	2.000 Meters

Date (MM-DD-YYYY)	06/06/2015
RMSE Hz	0.013
RMSE Z	N/A
GPS Method	RTK

PHOTOS:





Point ID	PP27
Project No.	26236
Project Name	DVRPC/NJ LIDAR
State	NEW JERSEY
County	BURLINGTON
Quad	BEVERLY

	Aerial Target
	LiDAR Ground Control
	LiDAR QC Point
	New Control
X	Photo ID
	Published Control

Coordinate System	
NAD83(2011)	
UTM – Zone 18N	
NAVD88	
GEOID12A	
Meters	

Northing	Easting	Elevation
4435802.656	510714.841	Hz Only

Operator	STEVE MILLER
Receiver Model	Trimble R-8, Model 3
Receiver S/N	5135472526
Antenna Height	2.000 Meters

Date (MM-DD-YYYY)	06/06/2015
RMSE Hz	0.014
RMSE Z	N/A
GPS Method	RTK

PHOTOS:





Point ID	PP28
Project No.	26236
Project Name	DVRPC/NJ LIDAR
State	NEW JERSEY
County	BURLINGTON
Quad	COLUMBUS

Aerial Target	
LiDAR Ground Control	
LiDAR QC Point	
New Control	
X Photo ID	
Published Control	

Coordinate System	NAD83(2011)
	UTM – Zone 18N
	NAVD88
	GEOID12A
	Meters

Northing	Easting	Elevation
4435822.956	524796.948	Hz Only

Operator	STEVE MILLER
Receiver Model	Trimble R-8, Model 3
Receiver S/N	5135472526
Antenna Height	2.000 Meters

Date (MM-DD-YYYY)	06/05/2015
RMSE Hz	0.013
RMSE Z	N/A
GPS Method	RTK

PHOTOS:





Point ID	PP29
Project No.	26236
Project Name	DVRPC/NJ LIDAR
State	NEW JERSEY
County	BURLINGTON
Quad	COLUMBUS

Aerial Target	
LiDAR Ground Control	
LiDAR QC Point	
New Control	
X Photo ID	
Published Control	

Coordinate System	NAD83(2011)
	UTM – Zone 18N
	NAVD88
	GEOID12A
	Meters

<b>Northing</b>	<b>Easting</b>	<b>Elevation</b>
4431932.173	526065.079	Hz Only

Operator	STEVE MILLER
Receiver Model	Trimble R-8, Model 3
Receiver S/N	5135472526
Antenna Height	2.000 Meters

Date (MM-DD-YYYY)	06/06/2015
RMSE Hz	0.013
RMSE Z	N/A
GPS Method	RTK/STATIC

PHOTOS:





Point ID	PP30
Project No.	26236
Project Name	DVRPC/NJ LIDAR
State	NEW JERSEY
County	BURLINGTON
Quad	PEMBERTON

	Aerial Target
	LiDAR Ground Control
	LiDAR QC Point
	New Control
X	Photo ID
	Published Control

Coordinate System
NAD83(2011)
UTM – Zone 18N
NAVD88
GEOID12A
Meters

Northing	Easting	Elevation
4428033.125	521657.284	Hz Only

Operator	STEVE MILLER
Receiver Model	Trimble R-8, Model 3
Receiver S/N	5135472526
Antenna Height	2.000 Meters

Date (MM-DD-YYYY)	06/06/2015
RMSE Hz	0.013
RMSE Z	N/A
GPS Method	RTK

PHOTOS:





Point ID	PP31
Project No.	26236
Project Name	DVRPC/NJ LIDAR
State	NEW JERSEY
County	BURLINGTON
Quad	MT. HOLLY

Aerial Target	
LiDAR Ground Control	
LiDAR QC Point	
New Control	
X Photo ID	
Published Control	

Coordinate System	NAD83(2011)
	UTM – Zone 18N
	NAVD88
	GEOID12A
	Meters

<b>Northing</b>	<b>Easting</b>	<b>Elevation</b>
4422373.713	516074.974	Hz Only

Operator	STEVE MILLER
Receiver Model	Trimble R-8, Model 3
Receiver S/N	5135472526
Antenna Height	2.000 Meters

Date (MM-DD-YYYY)	06/06/2015
RMSE Hz	0.014
RMSE Z	N/A
GPS Method	RTK

PHOTOS:





Point ID	PP32
Project No.	26236
Project Name	DVRPC/NJ LIDAR
State	NEW JERSEY
County	BURLINGTON
Quad	PEMBERTON

Aerial Target	
LiDAR Ground Control	
LiDAR QC Point	
New Control	
X Photo ID	
Published Control	

Coordinate System	NAD83(2011)
	UTM – Zone 18N
	NAVD88
	GEOID12A
	Meters

<b>Northing</b>	<b>Easting</b>	<b>Elevation</b>
4420514.781	521654.763	Hz Only

Operator	STEVE MILLER
Receiver Model	Trimble R-8, Model 3
Receiver S/N	5135472526
Antenna Height	2.000 Meters

Date (MM-DD-YYYY)	06/06/2015
RMSE Hz	0.013
RMSE Z	N/A
GPS Method	RTK

PHOTOS:







Point ID	PP33
Project No.	26236
Project Name	DVRPC/NJ LIDAR
State	NEW JERSEY
County	BURLINGTON
Quad	NEW GRETNA

Aerial Target	
LiDAR Ground Control	
LiDAR QC Point	
New Control	
X Photo ID	
Published Control	

Coordinate System	NAD83(2011)
	UTM – Zone 18N
	NAVD88
	GEOID12A
	Meters

<b>Northing</b>	<b>Easting</b>	<b>Elevation</b>
4380950.574	547130.742	Hz Only

Operator	STEVE MILLER
Receiver Model	Trimble R-8, Model 3
Receiver S/N	5135472526
Antenna Height	2.000 Meters

Date (MM-DD-YYYY)	06/12/2015
RMSE Hz	0.013
RMSE Z	N/A
GPS Method	RTK

PHOTOS:





Point ID	PP34
Project No.	26236
Project Name	DVRPC/NJ LIDAR
State	NEW JERSEY
County	BURLINGTON
Quad	NEW GREтна

Aerial Target	
LiDAR Ground Control	
LiDAR QC Point	
New Control	
X Photo ID	
Published Control	

Coordinate System	NAD83(2011)
	UTM – Zone 18N
	NAVD88
	GEOID12A
	Meters

<b>Northing</b>	<b>Easting</b>	<b>Elevation</b>
4382850.496	550074.422	Hz Only

Operator	STEVE MILLER
Receiver Model	Trimble R-8, Model 3
Receiver S/N	5135472526
Antenna Height	2.000 Meters

Date (MM-DD-YYYY)	06/12/2015
RMSE Hz	0.014
RMSE Z	N/A
GPS Method	RTK

PHOTOS:





Point ID	PP35
Project No.	26236
Project Name	DVRPC/NJ LIDAR
State	NEW JERSEY
County	BURLINGTON
Quad	NEW GRETN

Aerial Target	
LiDAR Ground Control	
LiDAR QC Point	
New Control	
X Photo ID	
Published Control	

Coordinate System	NAD83(2011)
	UTM – Zone 18N
	NAVD88
	GEOID12A
	Meters

Northing	Easting	Elevation
4386232.414	545747.687	Hz Only

Operator	STEVE MILLER
Receiver Model	Trimble R-8, Model 3
Receiver S/N	5135472526
Antenna Height	2.000 Meters

Date (MM-DD-YYYY)	06/12/2015
RMSE Hz	0.016
RMSE Z	N/A
GPS Method	RTK

PHOTOS:





Point ID	PP36
Project No.	26236
Project Name	DVRPC/NJ LIDAR
State	NEW JERSEY
County	BURLINGTON
Quad	GREEN BANK

	Aerial Target
	LiDAR Ground Control
	LiDAR QC Point
	New Control
X	Photo ID
	Published Control

Coordinate System	
NAD83(2011)	
UTM – Zone 18N	
NAVD88	
GEOID12A	
Meters	

<b>Northing</b>	<b>Easting</b>	<b>Elevation</b>
4382802.979	538699.364	Hz Only

Operator	STEVE MILLER
Receiver Model	Trimble R-8, Model 3
Receiver S/N	5135472526
Antenna Height	2.000 Meters

Date (MM-DD-YYYY)	06/12/2015
RMSE Hz	0.013
RMSE Z	N/A
GPS Method	RTK

PHOTOS:





Point ID	PP37
Project No.	26236
Project Name	DVRPC/NJ LIDAR
State	NEW JERSEY
County	BURLINGTON
Quad	GREEN BANK

	Aerial Target
	LiDAR Ground Control
	LiDAR QC Point
	New Control
X	Photo ID
	Published Control

Coordinate System	
NAD83(2011)	
UTM – Zone 18N	
NAVD88	
GEOID12A	
Meters	

Northing	Easting	Elevation
4385219.074	536174.202	Hz Only

Operator	STEVE MILLER
Receiver Model	Trimble R-8, Model 3
Receiver S/N	5135472526
Antenna Height	2.000 Meters

Date (MM-DD-YYYY)	06/13/2015
RMSE Hz	0.013
RMSE Z	N/A
GPS Method	RTK

PHOTOS:





Point ID	PP38
Project No.	26236
Project Name	DVRPC/NJ LIDAR
State	NEW JERSEY
County	BURLINGTON
Quad	JENKINS

	Aerial Target
	LiDAR Ground Control
	LiDAR QC Point
	New Control
X	Photo ID
	Published Control

Coordinate System	
NAD83(2011)	
UTM – Zone 18N	
NAVD88	
GEOID12A	
Meters	

Northing	Easting	Elevation
4386249.160	533210.512	Hz Only

Operator	STEVE MILLER
Receiver Model	Trimble R-8, Model 3
Receiver S/N	5135472526
Antenna Height	2.000 Meters

Date (MM-DD-YYYY)	06/13/2015
RMSE Hz	0.014
RMSE Z	N/A
GPS Method	RTK

PHOTOS:





Point ID	PP39
Project No.	26236
Project Name	DVRPC/NJ LIDAR
State	NEW JERSEY
County	BURLINGTON
Quad	JENKINS

	Aerial Target
	LiDAR Ground Control
	LiDAR QC Point
	New Control
X	Photo ID
	Published Control

Coordinate System	NAD83(2011)
	UTM – Zone 18N
	NAVD88
	GEOID12A
	Meters

Northing	Easting	Elevation
4392881.064	540011.099	Hz Only

Operator	STEVE MILLER
Receiver Model	Trimble R-8, Model 3
Receiver S/N	5135472526
Antenna Height	2.000 Meters

Date (MM-DD-YYYY)	06/13/2015
RMSE Hz	0.014
RMSE Z	N/A
GPS Method	RTK

PHOTOS:





Point ID	PP40
Project No.	26236
Project Name	DVRPC/NJ LIDAR
State	NEW JERSEY
County	BURLINGTON
Quad	JENKINS

Aerial Target	
LiDAR Ground Control	
LiDAR QC Point	
New Control	
X Photo ID	
Published Control	

Coordinate System	NAD83(2011)
	UTM – Zone 18N
	NAVD88
	GEOID12A
	Meters

Northing	Easting	Elevation
4399692.881	540320.818	Hz Only

Operator	STEVE MILLER
Receiver Model	Trimble R-8, Model 3
Receiver S/N	5135472526
Antenna Height	2.000 Meters

Date (MM-DD-YYYY)	06/13/2015
RMSE Hz	0.015
RMSE Z	N/A
GPS Method	RTK

PHOTOS:







Point ID	PP41
Project No.	26236
Project Name	DVRPC/NJ LIDAR
State	NEW JERSEY
County	BURLINGTON
Quad	CHATSWORTH

Aerial Target	
LiDAR Ground Control	
LiDAR QC Point	
New Control	
X Photo ID	
Published Control	

Coordinate System	NAD83(2011)
	UTM – Zone 18N
	NAVD88
	GEOID12A
	Meters

<b>Northing</b>	<b>Easting</b>	<b>Elevation</b>
4407411.835	539623.735	Hz Only

Operator	STEVE MILLER
Receiver Model	Trimble R-8, Model 3
Receiver S/N	5135472526
Antenna Height	2.000 Meters

Date (MM-DD-YYYY)	06/13/2015
RMSE Hz	0.014
RMSE Z	N/A
GPS Method	RTK

PHOTOS:





Point ID	PP42
Project No.	26236
Project Name	DVRPC/NJ LIDAR
State	NEW JERSEY
County	BURLINGTON
Quad	MEDFORD LAKES

Aerial Target	
LiDAR Ground Control	
LiDAR QC Point	
New Control	
X Photo ID	
Published Control	

Coordinate System	NAD83(2011)
	UTM – Zone 18N
	NAVD88
	GEOID12A
	Meters

<b>Northing</b>	<b>Easting</b>	<b>Elevation</b>
4404649.557	521126.691	Hz Only

Operator	STEVE MILLER
Receiver Model	Trimble R-8, Model 3
Receiver S/N	5135472526
Antenna Height	2.000 Meters

Date (MM-DD-YYYY)	06/14/2015
RMSE Hz	0.013
RMSE Z	N/A
GPS Method	RTK

PHOTOS:





Point ID	PP43
Project No.	26236
Project Name	DVRPC/NJ LIDAR
State	NEW JERSEY
County	BURLINGTON
Quad	MEDFORD LAKES

Aerial Target	
LiDAR Ground Control	
LiDAR QC Point	
New Control	
X Photo ID	
Published Control	

Coordinate System	NAD83(2011)
	UTM – Zone 18N
	NAVD88
	GEOID12A
	Meters

<b>Northing</b>	<b>Easting</b>	<b>Elevation</b>
4407625.902	520150.225	Hz Only

Operator	STEVE MILLER
Receiver Model	Trimble R-8, Model 3
Receiver S/N	5135472526
Antenna Height	2.000 Meters

Date (MM-DD-YYYY)	06/14/2015
RMSE Hz	0.013
RMSE Z	N/A
GPS Method	RTK

PHOTOS:





Point ID	PP44
Project No.	26236
Project Name	DVRPC/NJ LIDAR
State	NEW JERSEY
County	BURLINGTON
Quad	INDIAN MILLS

	Aerial Target
	LiDAR Ground Control
	LiDAR QC Point
	New Control
X	Photo ID
	Published Control

Coordinate System	
NAD83(2011)	
UTM – Zone 18N	
NAVD88	
GEOID12A	
Meters	

<b>Northing</b>	<b>Easting</b>	<b>Elevation</b>
4413156.894	529461.940	Hz Only

Operator	STEVE MILLER
Receiver Model	Trimble R-8, Model 3
Receiver S/N	5135472526
Antenna Height	2.000 Meters

Date (MM-DD-YYYY)	06/14/2015
RMSE Hz	0.010
RMSE Z	N/A
GPS Method	RTK

PHOTOS:





Point ID	PP45
Project No.	26236
Project Name	DVRPC/NJ LIDAR
State	NEW JERSEY
County	BURLINGTON
Quad	CHATSWORTH

Aerial Target	
LiDAR Ground Control	
LiDAR QC Point	
New Control	
X Photo ID	
Published Control	

Coordinate System	NAD83(2011)
	UTM – Zone 18N
	NAVD88
	GEOID12A
	Meters

<b>Northing</b>	<b>Easting</b>	<b>Elevation</b>
4407977.848	535353.131	Hz Only

Operator	STEVE MILLER
Receiver Model	Trimble R-8, Model 3
Receiver S/N	513572526
Antenna Height	2.000 Meters

Date (MM-DD-YYYY)	06/14/2015
RMSE Hz	0.011
RMSE Z	N/A
GPS Method	RTK

PHOTOS:





Point ID	PP46
Project No.	26236
Project Name	DVRPC/NJ LIDAR
State	NEW JERSEY
County	BURLINGTON
Quad	TRENTON EAST

	Aerial Target
	LiDAR Ground Control
	LiDAR QC Point
	New Control
X	Photo ID
	Published Control

Coordinate System
NAD83(2011)
UTM – Zone 18N
NAVD88
GEOID12A
Meters

Northing	Easting	Elevation
4449208.851	523985.748	Hz Only

Operator	STEVE MILLER
Receiver Model	Trimble R-8, Model 3
Receiver S/N	5135472526
Antenna Height	2.000 Meters

Date (MM-DD-YYYY)	06/15/2015
RMSE Hz	0.013
RMSE Z	N/A
GPS Method	RTK

PHOTOS:





Point ID	PP47
Project No.	26236
Project Name	DVRPC/NJ LIDAR
State	NEW JERSEY
County	BURLINGTON
Quad	ALLENTOWN

Aerial Target	
LiDAR Ground Control	
LiDAR QC Point	
New Control	
X Photo ID	
Published Control	

Coordinate System	NAD83(2011)
	UTM – Zone 18N
	NAVD88
	GEOID12A
	Meters

Northing	Easting	Elevation
4454789.165	536143.546	Hz Only

Operator	STEVE MILLER
Receiver Model	Trimble R-8, Model 3
Receiver S/N	5135472526
Antenna Height	2.000 Meters

Date (MM-DD-YYYY)	06/15/2015
RMSE Hz	0.013
RMSE Z	N/A
GPS Method	RTK

PHOTOS:





Point ID	PP100
Project No.	26236
Project Name	DELAWARE VALLEY LiDAR
State	New Jersey
County	Burlington
Quad	Whiting

	Aerial Target
	LiDAR Ground Control
	LiDAR QC Point
	New Control
X	Photo ID
	Published Control

Coordinate System	
NAD83(2011)	
UTM – Zone 18N	
NAVD88	
GEOID12A	
Meters	

Northing	Easting	Elevation
4422282.966	543749.424	Hz Only

Operator	Kevin Chapman
Receiver Model	Trimble R-8, Model 3
Receiver S/N	5106461067
Antenna Height	2.000 Meters

Date (MM-DD-YYYY)	06/12/2015
RMSE Hz	0.013
RMSE Z	N/A
GPS Method	Keynet VRS

PHOTOS:







Point ID	PP101
Project No.	26236
Project Name	DELAWARE VALLEY LiDAR
State	New Jersey
County	Burlington
Quad	Woodmansie

Aerial Target	
LiDAR Ground Control	
LiDAR QC Point	
New Control	
X Photo ID	
Published Control	

Coordinate System	NAD83(2011)
	UTM – Zone 18N
	NAVD88
	GEOID12A
	Meters

<b>Northing</b>	<b>Easting</b>	<b>Elevation</b>
4409659.788	545783.659	Hz Only

Operator	Kevin Chapman
Receiver Model	Trimble R-8, Model 3
Receiver S/N	5106461067
Antenna Height	2.000 Meters

Date (MM-DD-YYYY)	06/12/2015
RMSE Hz	0.014
RMSE Z	N/A
GPS Method	Keynet VRS

PHOTOS:





Point ID	PP102
Project No.	26236
Project Name	DELAWARE VALLEY LiDAR
State	New Jersey
County	Burlington
Quad	New Egypt

	Aerial Target
	LiDAR Ground Control
	LiDAR QC Point
	New Control
X	Photo ID
	Published Control

Coordinate System	
NAD83(2011)	
UTM – Zone 18N	
NAVD88	
GEOID12A	
Meters	

Northing	Easting	Elevation
4439942.569	532726.226	Hz Only

Operator	Kevin Chapman
Receiver Model	Trimble R-8, Model 3
Receiver S/N	5106461067
Antenna Height	2.000 Meters

Date (MM-DD-YYYY)	06/13/2015
RMSE Hz	0.011
RMSE Z	N/A
GPS Method	Keynet VRS

PHOTOS:





Point ID	PP103
Project No.	26236
Project Name	DELAWARE VALLEY LiDAR
State	New Jersey
County	Burlington
Quad	Browns Mills

Aerial Target	
LiDAR Ground Control	
X LiDAR QC Point	
New Control	
Photo ID	
Published Control	

Coordinate System	NAD83(2011)
	UTM – Zone 18N
	NAVD88
	GEOID12A
	Meters

Northing	Easting	Elevation
4452470.121	519385.595	Hz Only

Operator	Kevin Chapman
Receiver Model	Trimble R-8, Model 3
Receiver S/N	5106461067
Antenna Height	2.000 Meters

Date (MM-DD-YYYY)	06/13/2015
RMSE Hz	0.015
RMSE Z	N/A
GPS Method	Keynet VRS

PHOTOS:





Point ID	PP104
Project No.	26236
Project Name	DELAWARE VALLEY LiDAR
State	New Jersey
County	Mercer
Quad	Princeton

Aerial Target	
LiDAR Ground Control	
X LiDAR QC Point	
New Control	
Photo ID	
Published Control	

Coordinate System	NAD83(2011)
	UTM – Zone 18N
	NAVD88
	GEOID12A
	Meters

<b>Northing</b>	<b>Easting</b>	<b>Elevation</b>
4467425.138	522820.489	Hz Only

Operator	Kevin Chapman
Receiver Model	Trimble R-8, Model 3
Receiver S/N	5106461067
Antenna Height	2.000 Meters

Date (MM-DD-YYYY)	06/14/2015
RMSE Hz	0.014
RMSE Z	N/A
GPS Method	Keynet VRS

PHOTOS:





Point ID	PP105
Project No.	26236
Project Name	DELAWARE VALLEY LiDAR
State	New Jersey
County	Mercer
Quad	Pennington

Aerial Target	
LiDAR Ground Control	
X LiDAR QC Point	
New Control	
Photo ID	
Published Control	

Coordinate System	NAD83(2011)
	UTM – Zone 18N
	NAVD88
	GEOID12A
	Meters

<b>Northing</b>	<b>Easting</b>	<b>Elevation</b>
4459656.141	518009.289	Hz Only

Operator	Kevin Chapman
Receiver Model	Trimble R-8, Model 3
Receiver S/N	5106461067
Antenna Height	2.000 Meters

Date (MM-DD-YYYY)	06/14/2015
RMSE Hz	0.014
RMSE Z	N/A
GPS Method	Keynet VRS

PHOTOS:





Point ID	PP106
Project No.	26236
Project Name	DELAWARE VALLEY LiDAR
State	New Jersey
County	Mercer
Quad	Trenton West

Aerial Target	
LiDAR Ground Control	
X LiDAR QC Point	
New Control	
Photo ID	
Published Control	

Coordinate System	NAD83(2011)
	UTM – Zone 18N
	NAVD88
	GEOID12A
	Meters

Northing	Easting	Elevation
4452470.121	519385.595	Hz Only

Operator	Kevin Chapman
Receiver Model	Trimble R-8, Model 3
Receiver S/N	5106461067
Antenna Height	2.000 Meters

Date (MM-DD-YYYY)	06/14/2015
RMSE Hz	0.014
RMSE Z	N/A
GPS Method	Keynet VRS

PHOTOS:

