

Project Report Appendices

The following section contains the appendices as listed in
the Connecticut River Basin, VT
2016 QL2 Project Report.

Appendix A

GPS/IMU Processing Statistics Flight Logs

There were 28 total lifts. Graph reports generated from processing software and flight logs are found on the following pages.

Nov 1, 2016-A (N73TM, SN7178).....	2	Nov 14, 2016-B (N22GE, SN7161)	190
Flight Log	9	Flight Log	198
Nov 1, 2016-B (N73TM, SN7178).....	10	Nov 15, 2016-A (N73TM, SN7178)	199
Flight Log	17	Flight Log	207
Nov 7, 2016-A (N22GE, SN7161).....	18	Nov 18, 2016-A (N22GE, SN7161)	208
Flight Log	26	Flight Log	216
Nov 7, 2016-A (N73TM, SN7178).....	27	Nov 18, 2016-B (N22GE, SN7161)	217
Flight Log	34	Flight Log	225
Nov 7, 2016-B (N22GE, SN7161).....	35	Nov 19, 2016-A (N22GE, SN7161)	226
Flight Log	43	Flight Log	234
Nov 7, 2016-B (N73TM, SN7178)	44	Nov 19, 2016-A (N73TM, SN7178)	235
Flight Log	52	Flight Log	243
Nov 8, 2016-A (N22GE, SN7161).....	53		
Flight Log	61		
Nov 8, 2016-A (N73TM, SN7178).....	62		
Flight Log	71		
Nov 8, 2016-B (N22GE, SN7161).....	72		
Flight Log	80		
Nov 8, 2016-B (N73TM, SN7178)	81		
Flight Log	89		
Nov 10, 2016-A (N22GE, SN7161).....	90		
Flight Log	97		
Nov 10, 2016-A (N73TM, SN7178).....	98		
Flight Log	105		
Nov 10, 2016-B (N22GE, SN7161)	106		
Flight Log	113		
Nov 10, 2016-B (N73TM, SN7178)	114		
Flight Log	122		
Nov 12, 2016-A (N73TM, SN7178)	123		
Flight Log	131		
Nov 12, 2016-B (N73TM, SN7178).....	132		
Flight Log	139		
Nov 13, 2016-A (N22GE, SN7161)	140		
Flight Log	147		
Nov 13, 2016-A (N73TM, SN7178)	148		
Flight Log	156		
Nov 13, 2016-B (N22GE, SN7161)	157		
Flight Log	164		
Nov 13, 2016-B (N73TM, SN7178).....	165		
Flight Log	172		
Nov 14, 2016-A (N22GE, SN7161).....	173		
Flight Log	181		
Nov 14, 2016-A (N73TM, SN7178)	182		
Flight Log	189		

Nov 1, 2016-A (N73TM, SN7178)

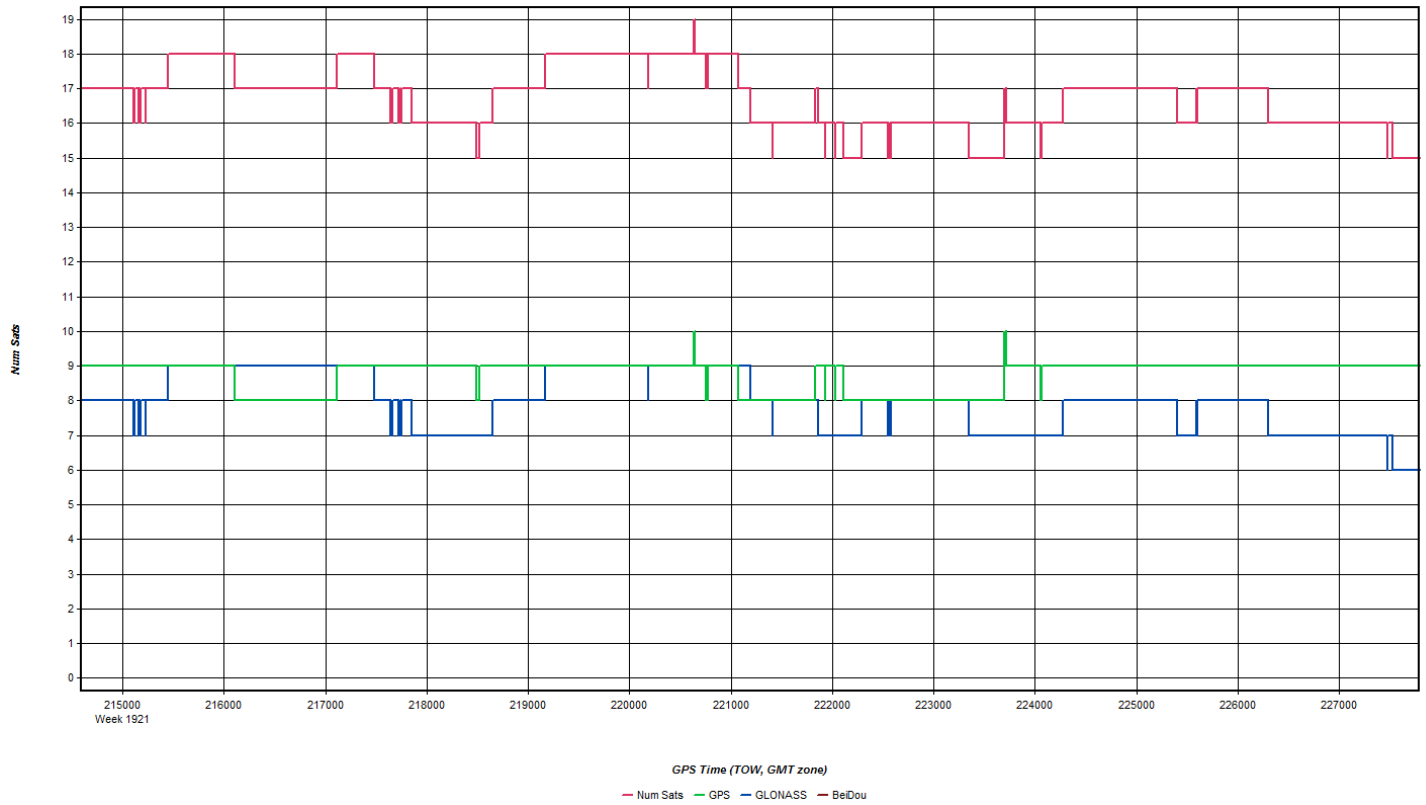
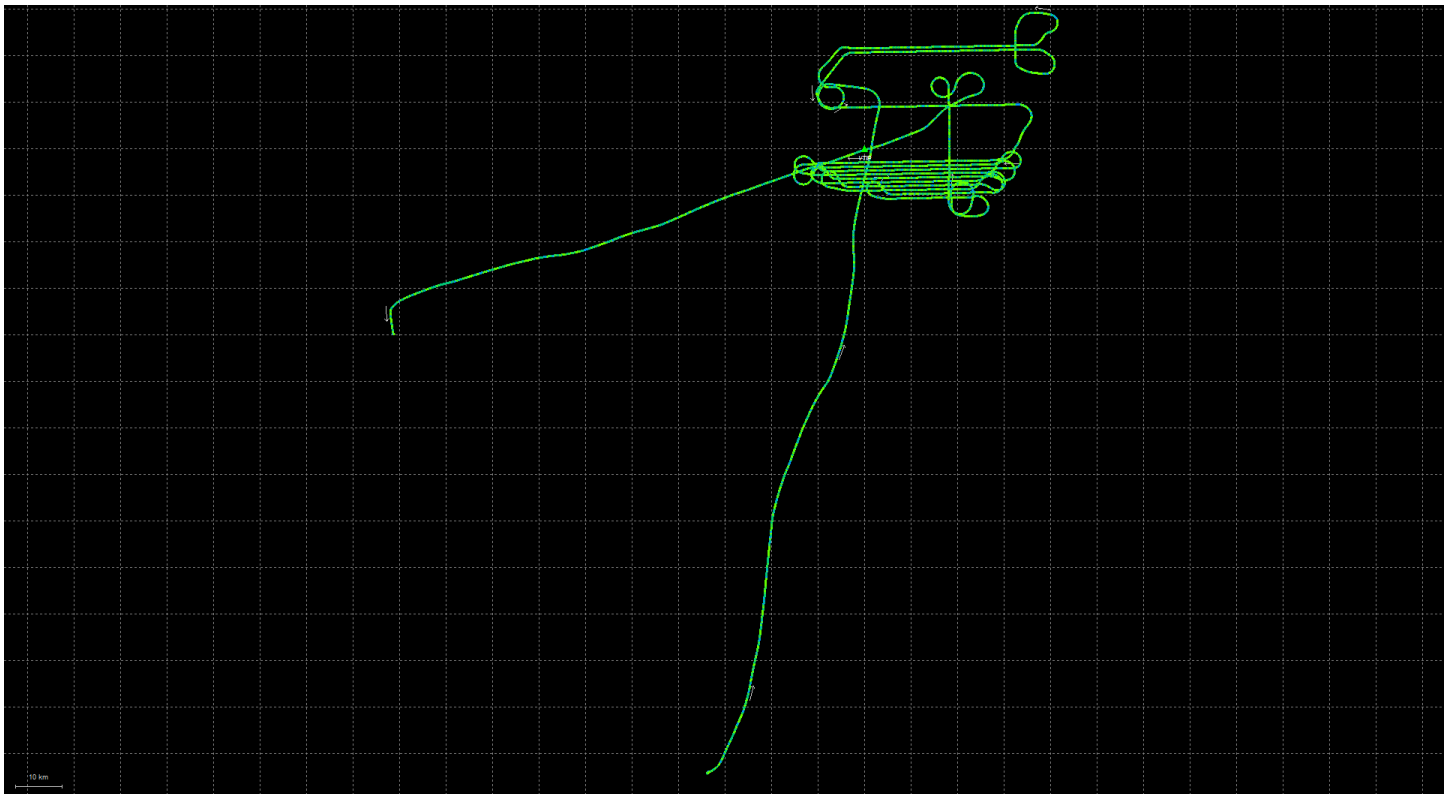

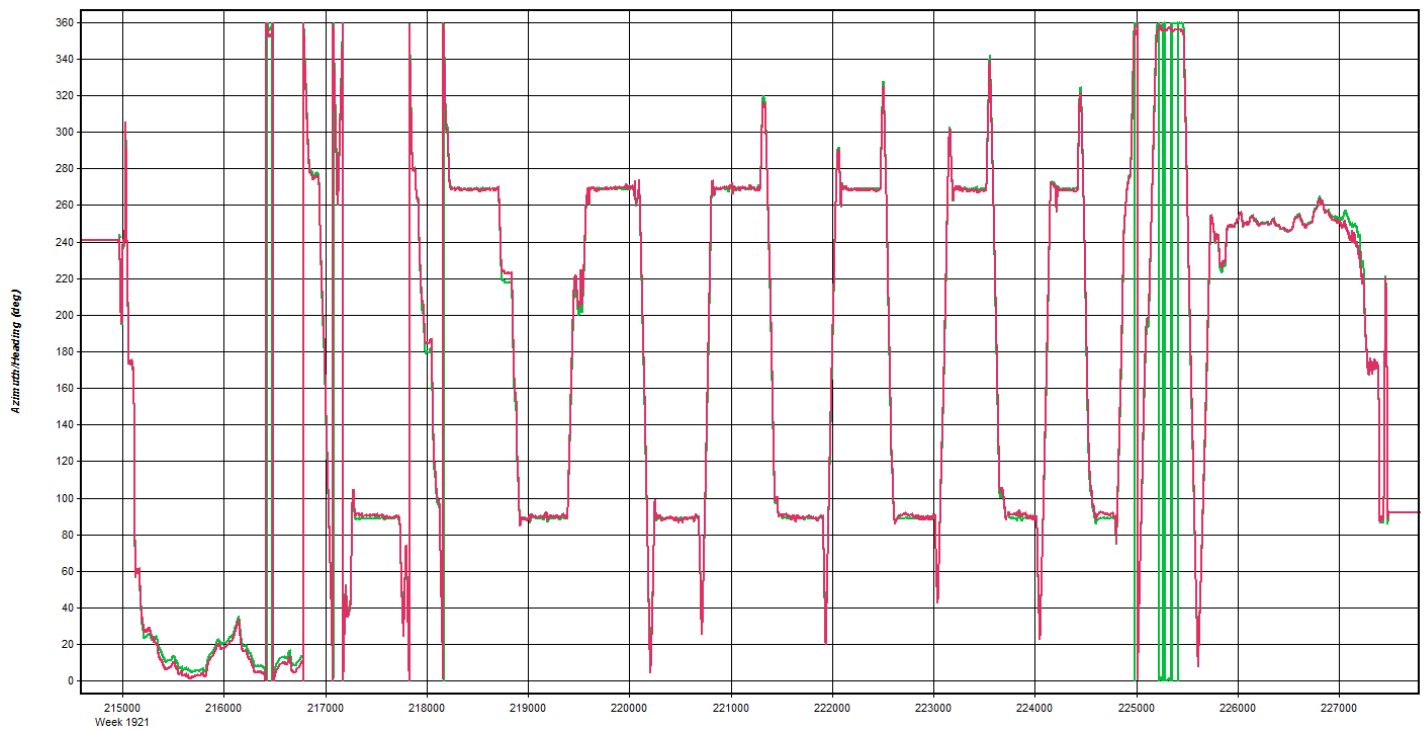
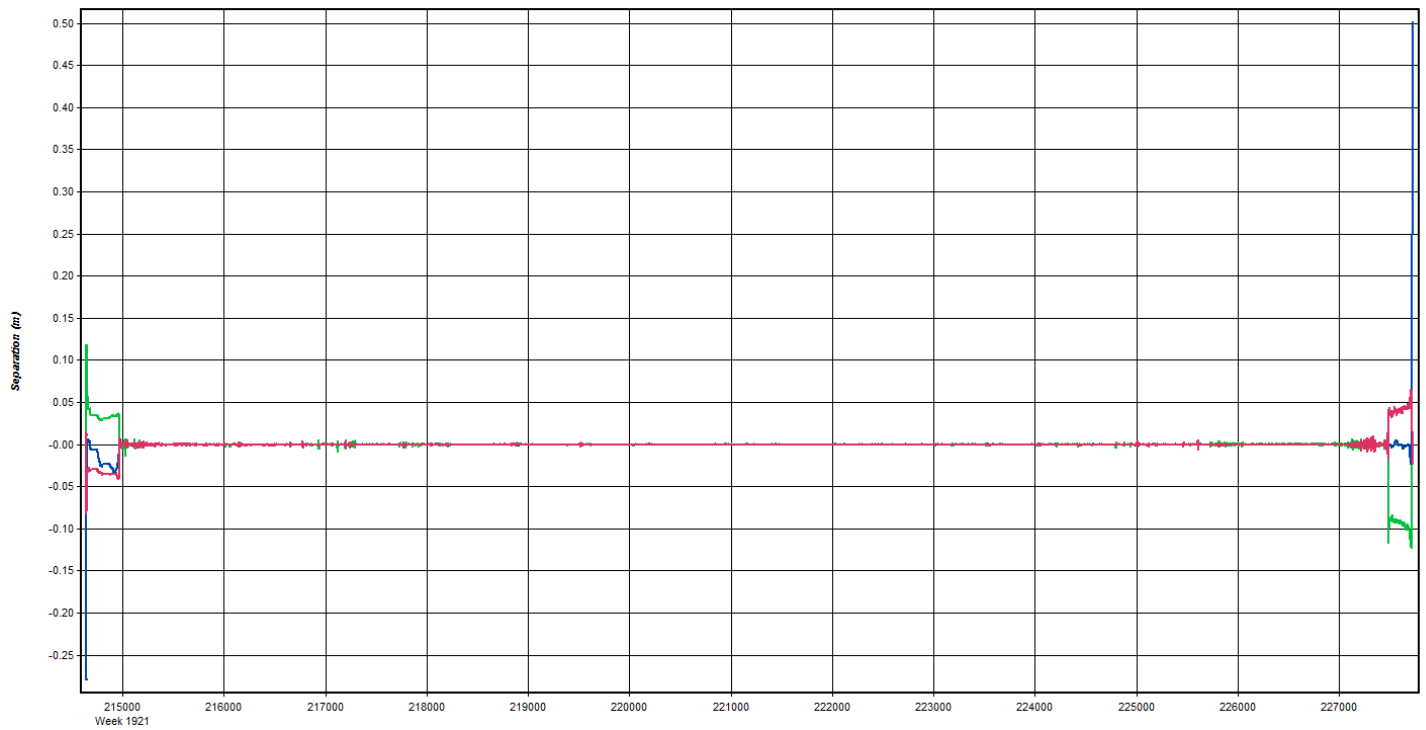

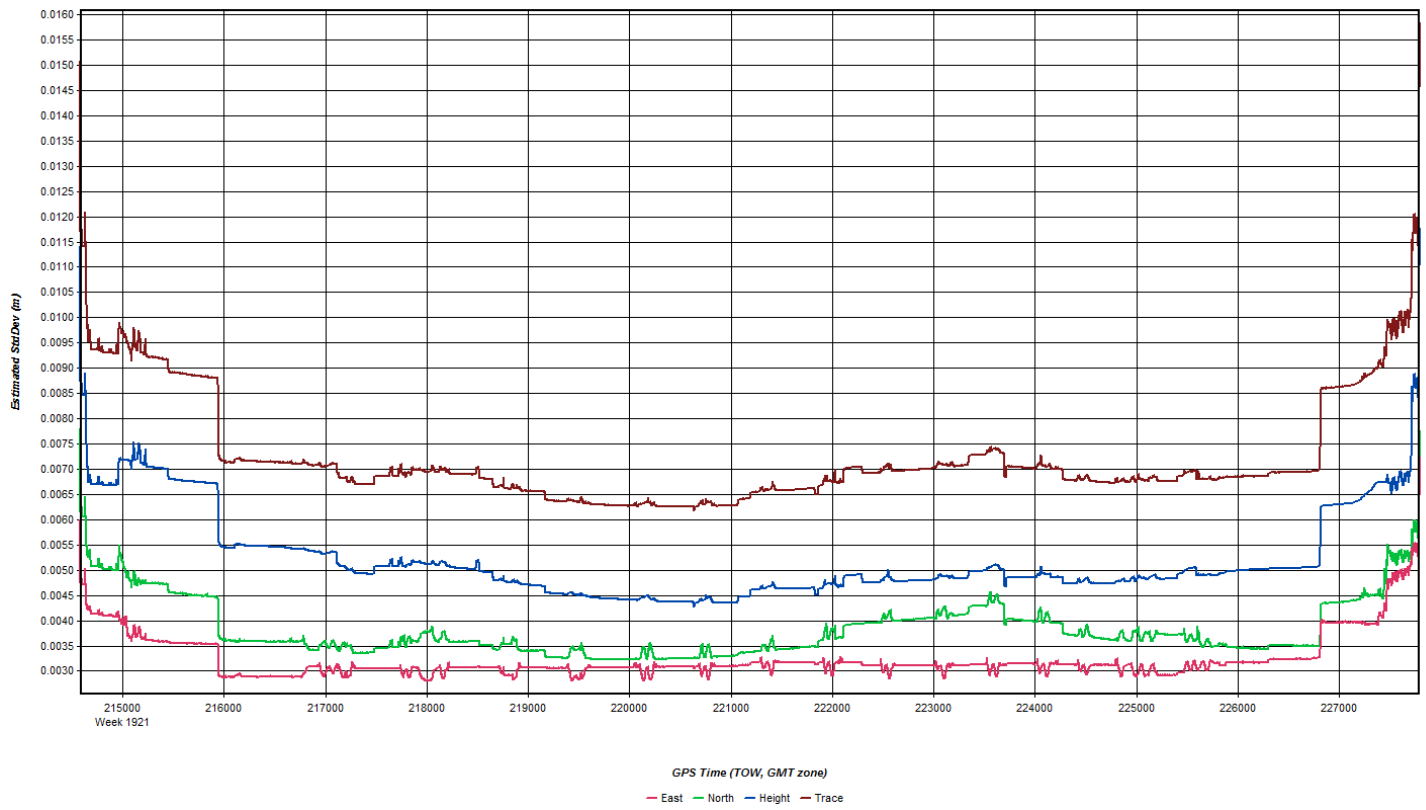
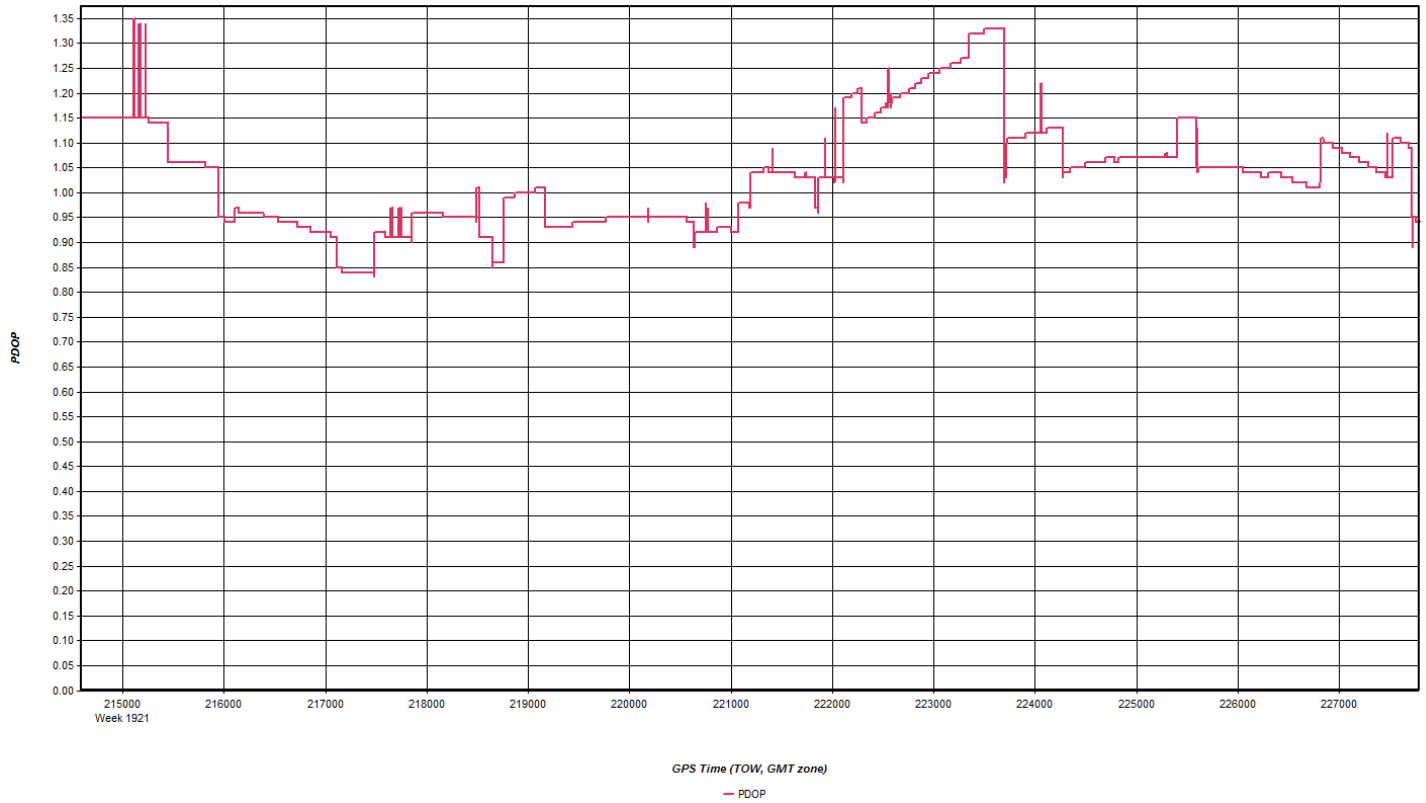

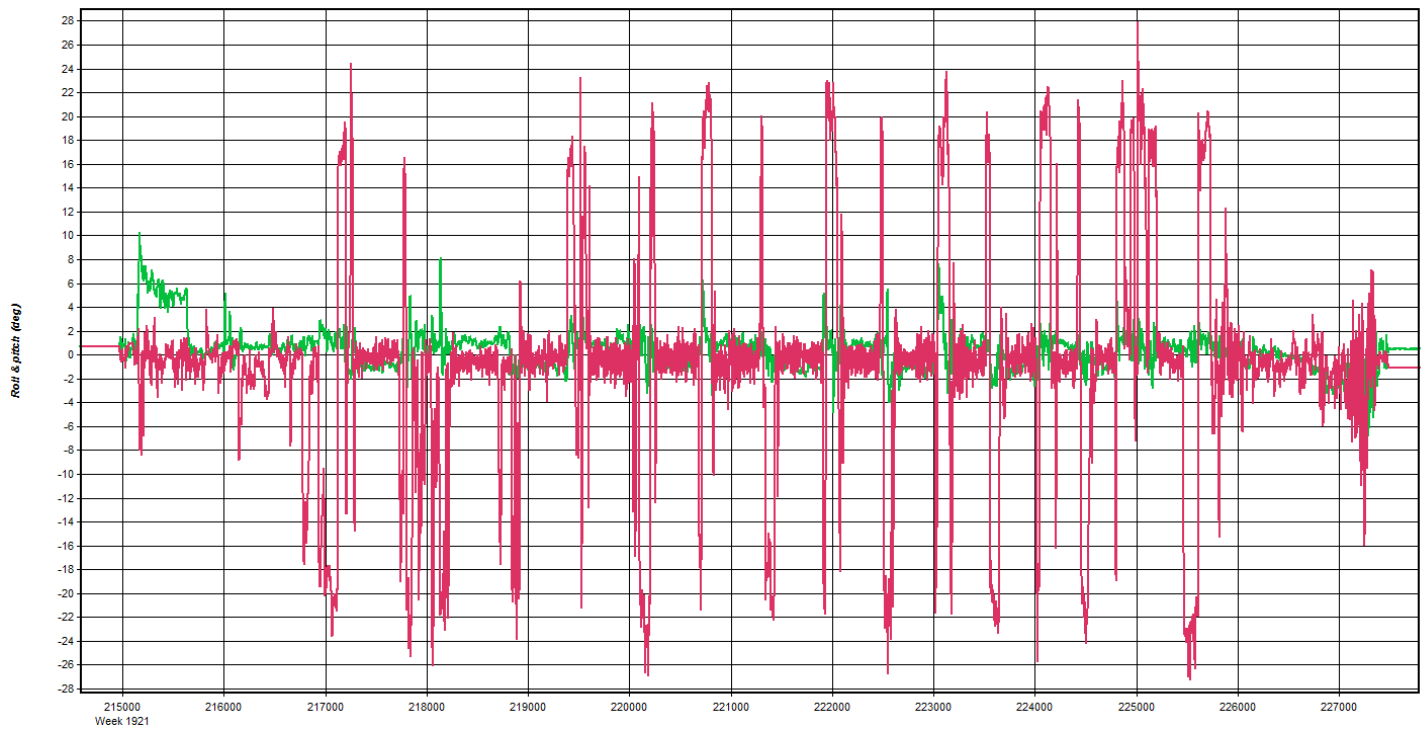

GPS Time (TOW, GMT zone)

— Roll — Pitch

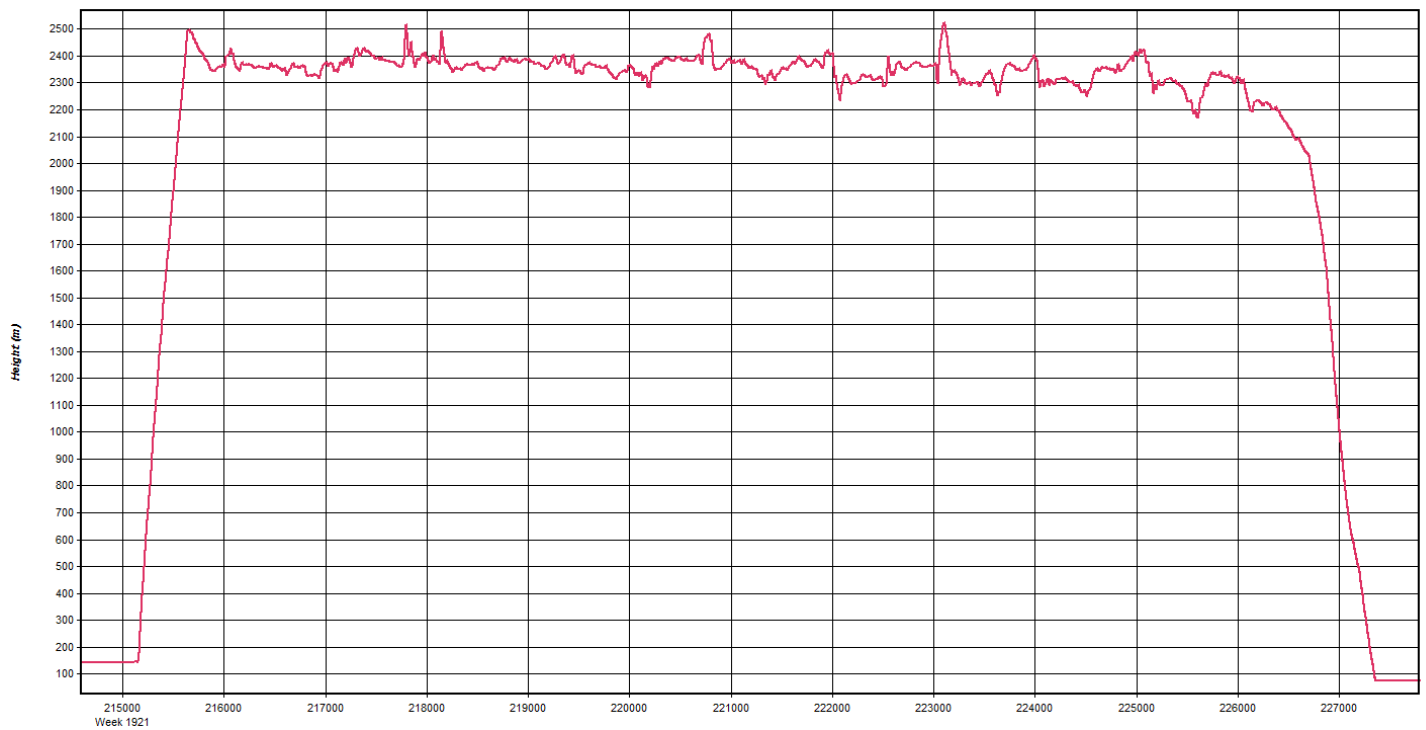

GPS Time (TOW, GMT zone)

— Height

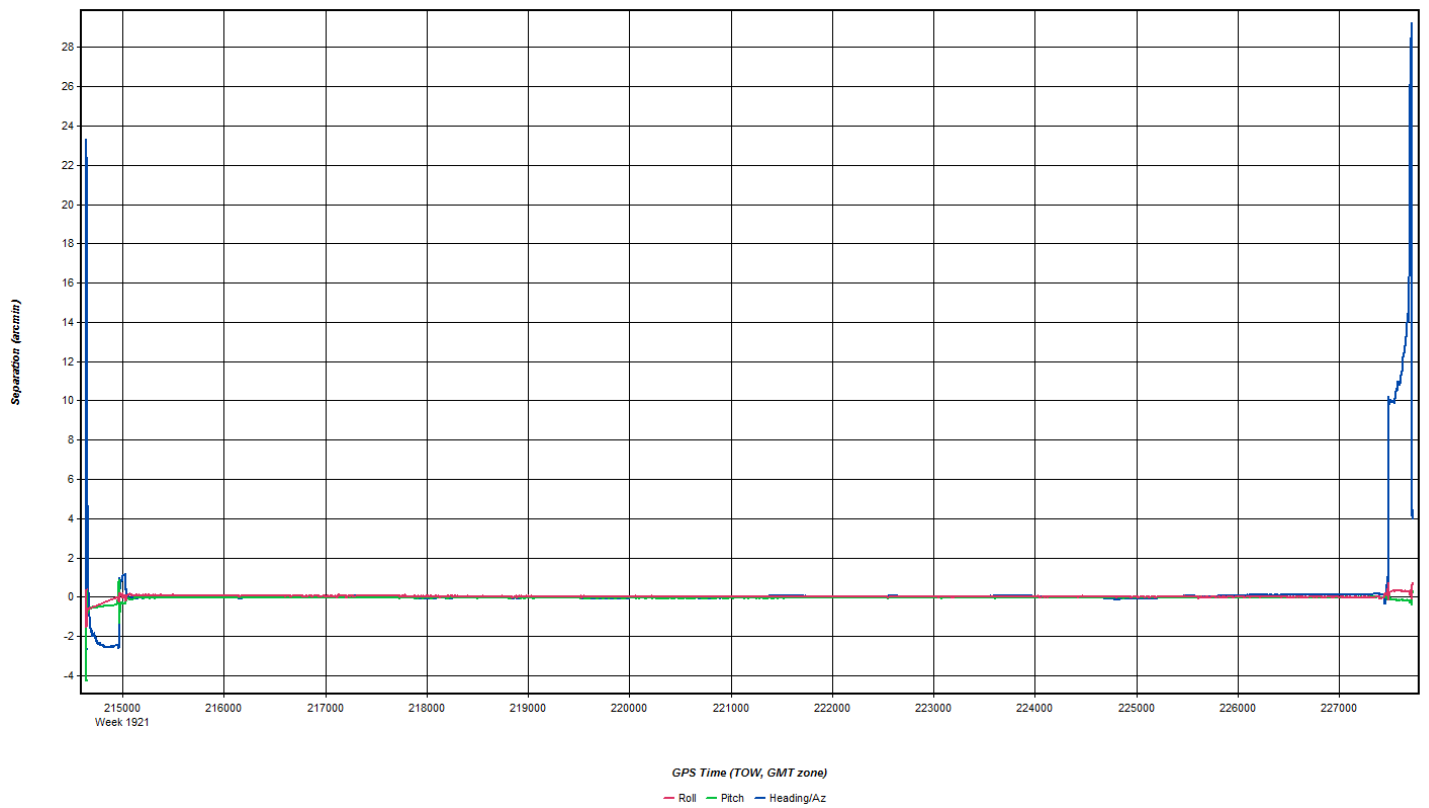
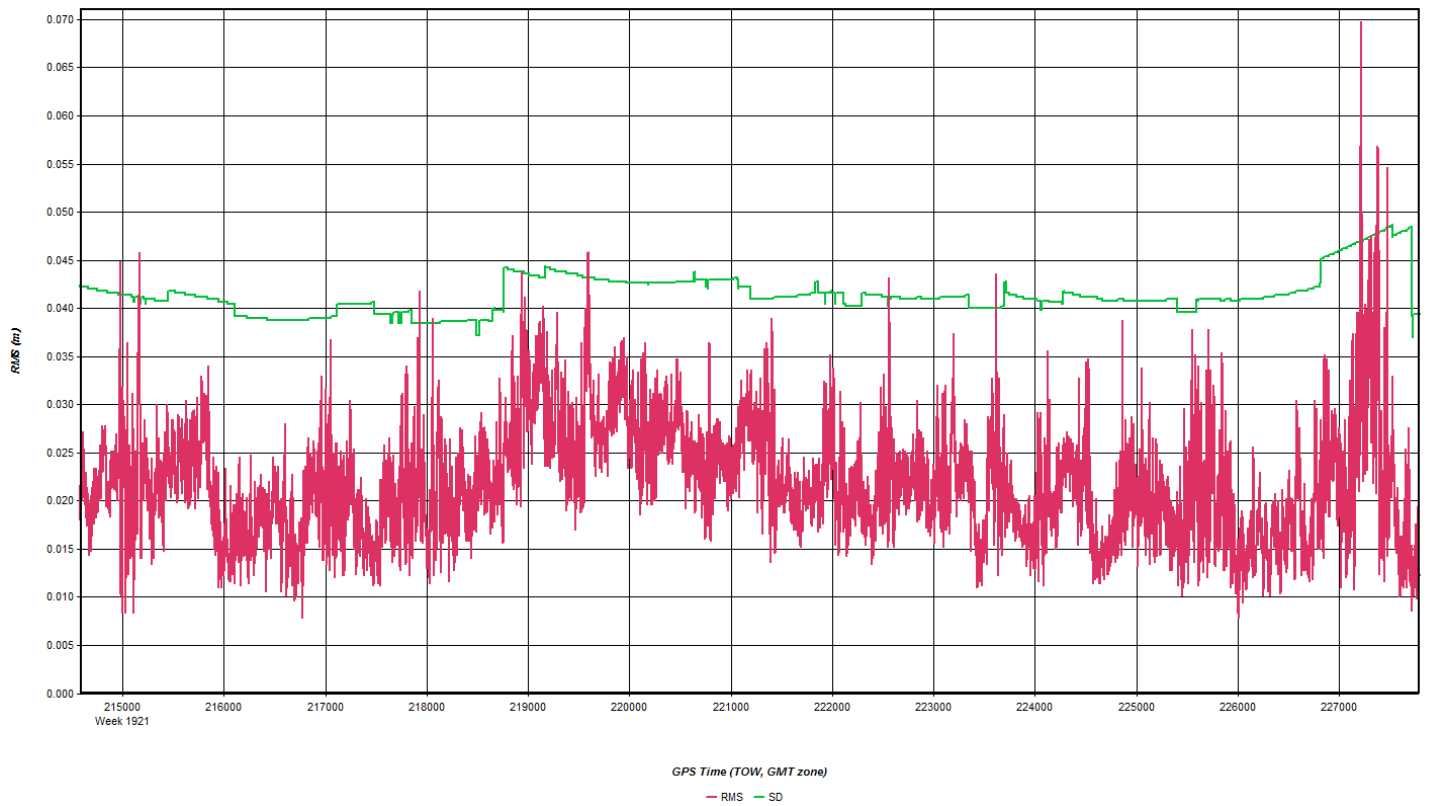

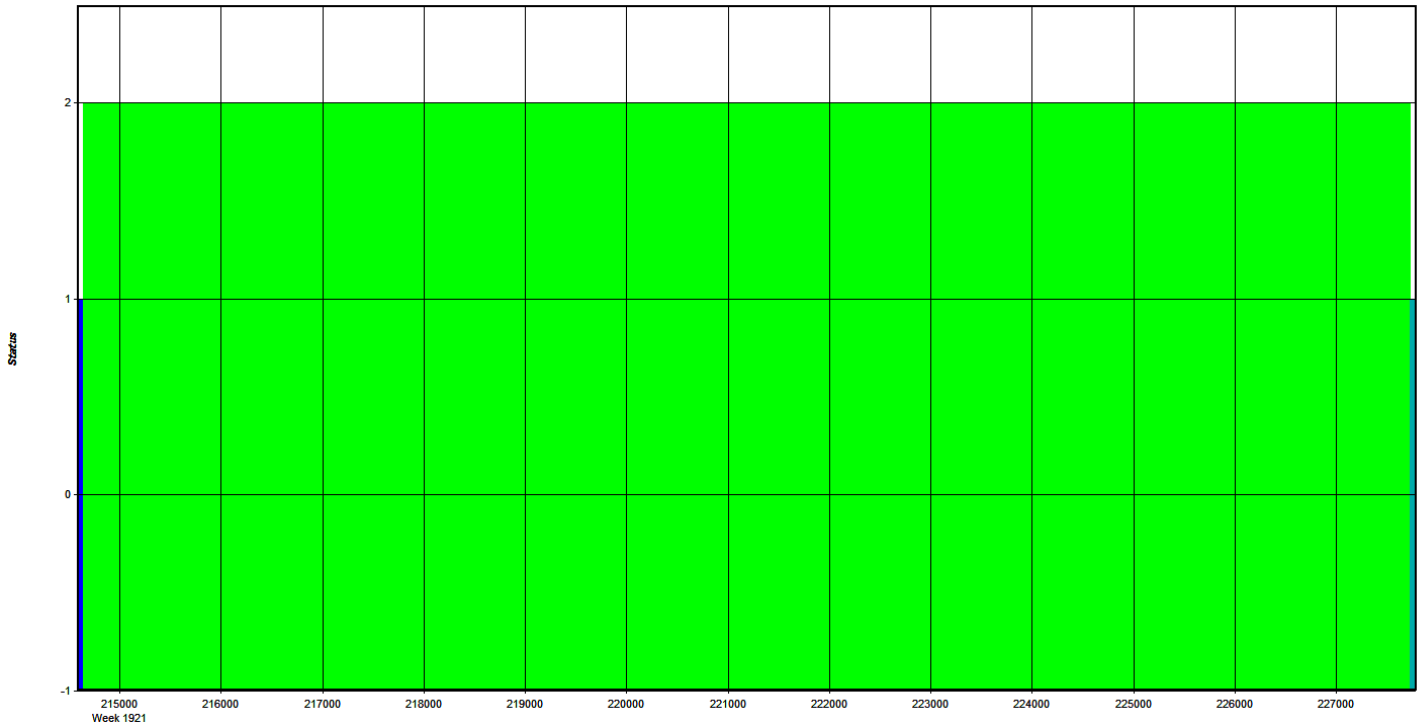

GPS Time (TOW, GMT zone)
 - Float - Forward Fixed - Reverse Fixed - Fixed (2 or more)

Coordinate/Antenna Settings

Master Remote

Base Station
 1: VTIP Name: VTIP Disabled
 File: E:\Proc\29178_VT_CT_River_Basin\20161101_AB_29178_ALS7

Coordinates
 Latitude: North 44 49 12.18043 Compute from PPP
 Longitude: West 71 53 25.83872 Enter Grid Values
 Ellipsoidal height: 341.732 m Enter MSL Height
 Datum: WGS84 Datum Options
 Select From Favorites Add To Favorites Use Average Position

Antenna Height
 From station file: TRM55971.00, NONE View STA File
 Antenna profile: TRM55971.00 Info
 Measured height: 0.000 m
 ARP to L1 offset: 0.067 m
 Applied height: 0.067 m
 Measured to:
 ARP
 L1 Phase Centre
 Compute From Slant

OK Cancel

Flight Log

Scanned by CamScanner

Project: VSGS CT RIVER BASIN **Proj #:** 29178 **Flight Mgmt File:** 29178 - VSGS - WINDSOR CO - SN718 2016101-113301
(email Log daily to flight_log_distribution_list@quantumspatial.com)

Aircraft: N73TM **Begin Hobbs:** 6459.8 **Total:** 34 **Pilot:** BILKINGTON **Co-Pilot:** - **Tech:** MADDY

Dep Apt: LEB **Dep Time (Lcl):** 0745 [Z]: 1145 **Arr Apt:** DTN **Arr Time (Local):** 1110 [Z]: 1510 **Tot Time Aloft:** 3:35

CORS: (Y) N **Sta 1:** VTIP **Sta 2:** **Flyovers:** (Y) / N **IF Y, times: Sta 1** ? / 1446 **Sta 2** **Sta 2**

GPS Unit: Y / (N) **Sta 1:** **Sta 2:** **Flyovers:** Y / N **IF Y, times: Sta 1** **Sta 2**

Type	Serial #	End: °C	OAT beg: °C	Alt AMSL ± 7800'	Alt AGL ± 5700'	GPS Altitude	GPS Altitude	Crab	Turn (0-1)	Altimeter begin:			Avg Ft Spacing	Max Gdspd	Power	PPSM	Bag CB	End CB	Tot CB	Storage Name#	
										Avg Terr Ht ± 1500'	Pulse Rate 260.4 KHZ	Power 100%									
LIDAR	4570	7178																			
FOV	40°	53.42																			

Line #	Hdg	Start (UTC)	End (UTC)	Gd Spd	FOF/F-SAS	GPS Altitude	Crab	Turn (0-1)	FLIGHT LINE NOTES - visibility, clouds, smoke, partial, etc.
4001	089	1221	1229	163		7820	1	0	- SNOW 9-12, SMALL PMAI F06 13
4002	180	1233	1233	172		7800	0	0	- MANUAL TIE LINE FOR LINKS 4001+4002
4003	269	1237	1244	162		7730	0	0	- LIGHT SNOW 15-14, SNOW 9-12
4004	90	1249	1256	160		7760	0	0	- SNOW THROUGHOUT RESUME?
4005	269	1259	1306	158		7760	0	0	- LIGHT SNOW MALE 0-1
4006	089	1311	1317	157		7840	1	0	- SNOW 0-2
4007	269	1320	1327	164		7710	0	0	- LIGHT SNOW MALE 5, 0-2
4008	089	1331	1338	159		7730	0	0	- SNOW 0-1
4009	269	1341	1347	153		7640	0	0	- SNOW 4 0-1
4010	089	1350	1356	158		7720	1	0	- SNOW 0-4
4011	269	1359	1404	163		7670	1	0	- SNOW 12
4012	089	1408	1413	157		7780	0	0	- LIGHT SNOW 3-6
4013	269	1417	1419	155		7600	0	0	- SNOW 1-2
4014	089	1424	1426	156		7720	0	0	
4015	269	1433	1437	176		7590	0	0	- TIE LINE FOR LINKS 4030-4039

Nov 1, 2016-B (N73TM, SN7178)

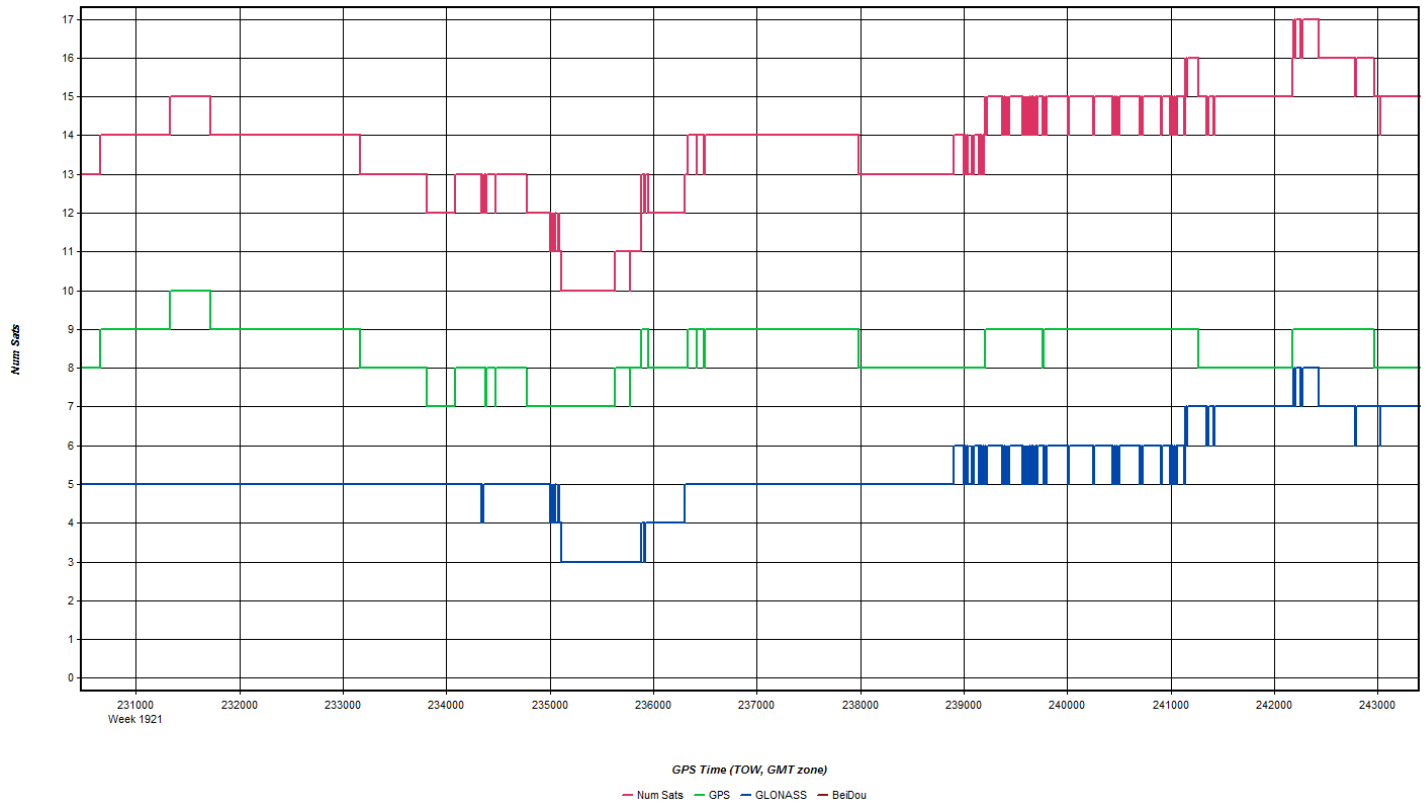
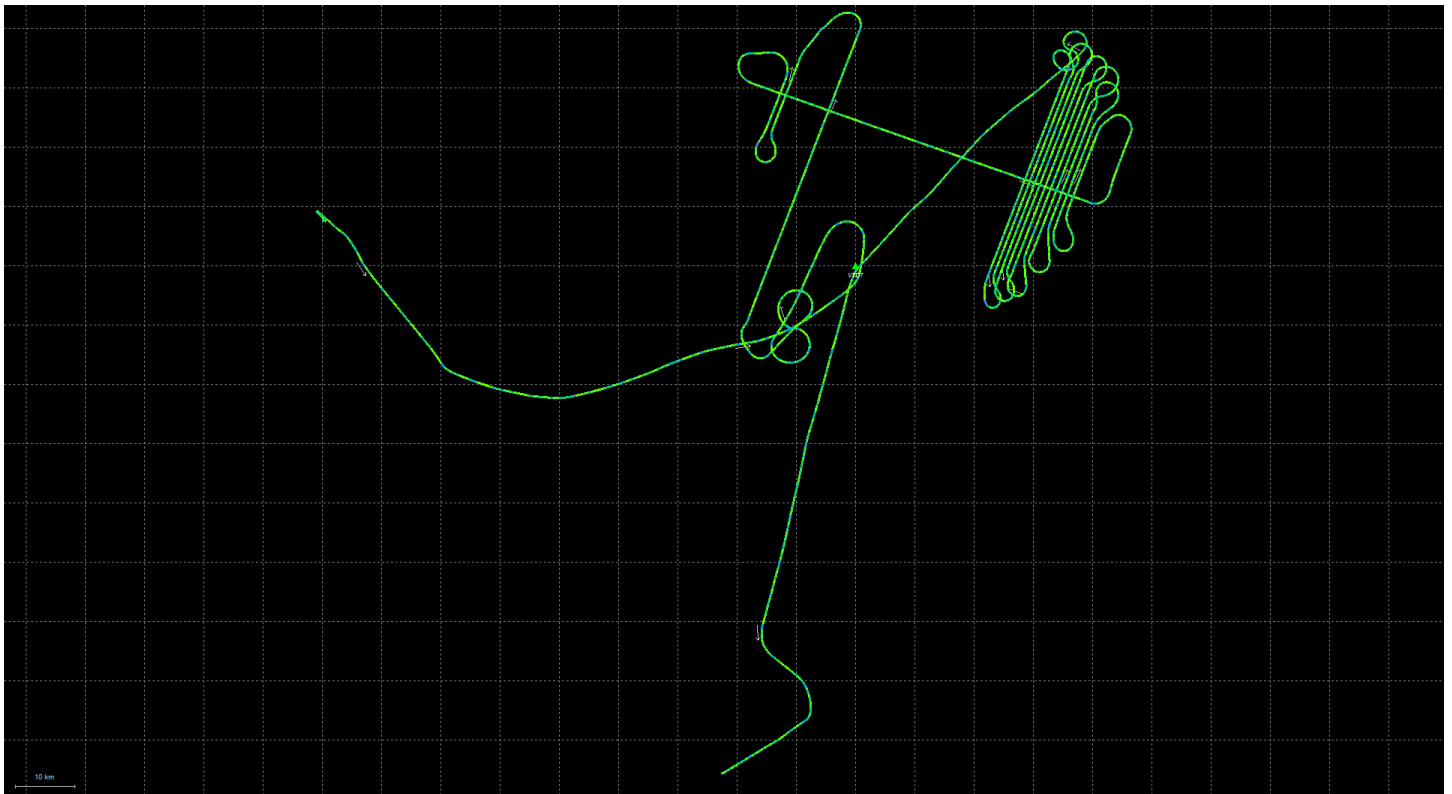

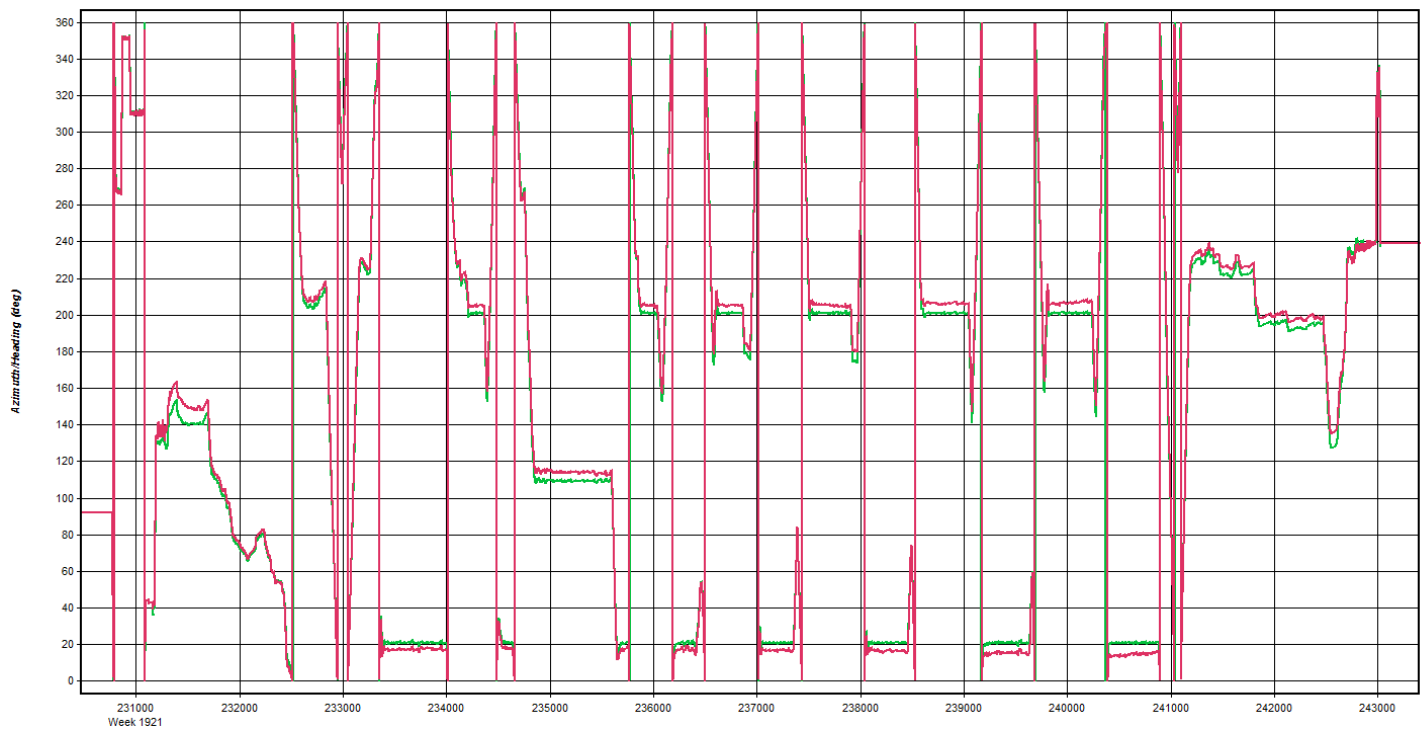
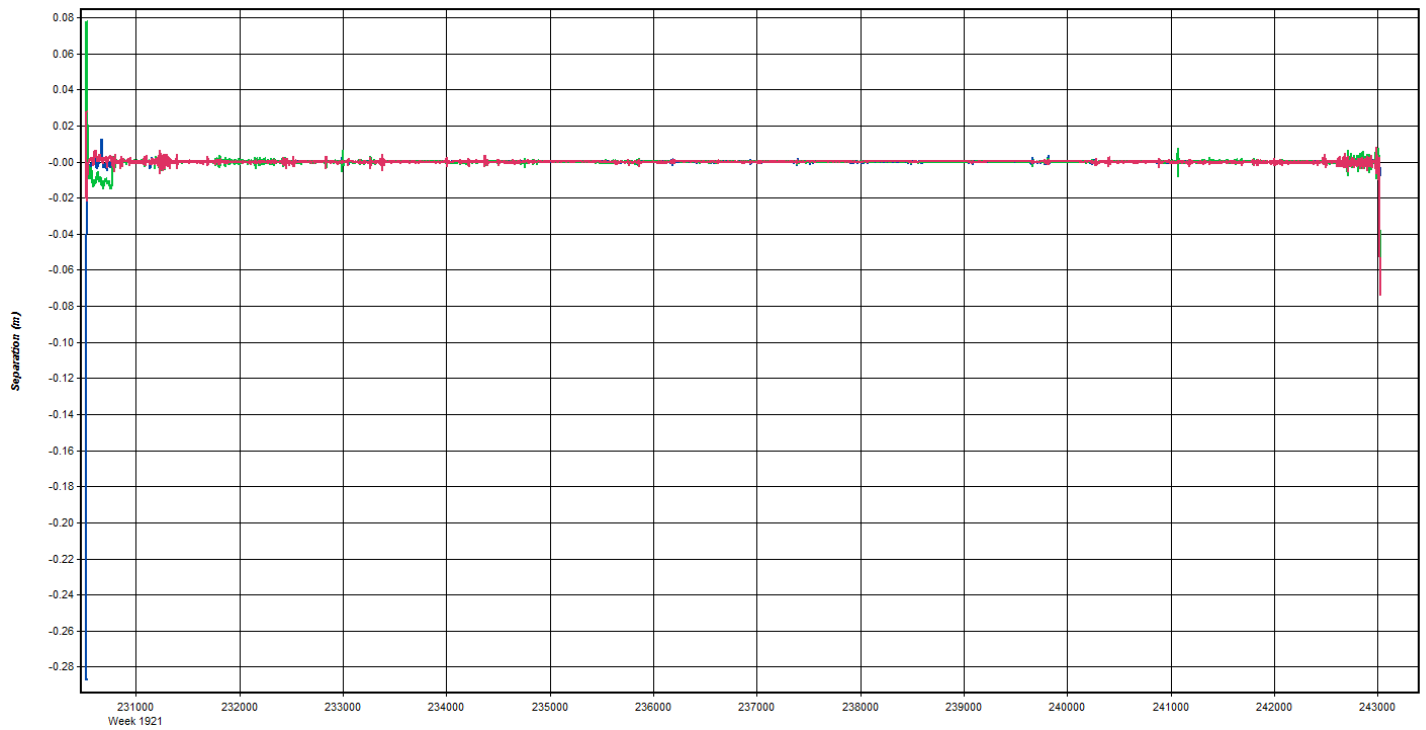

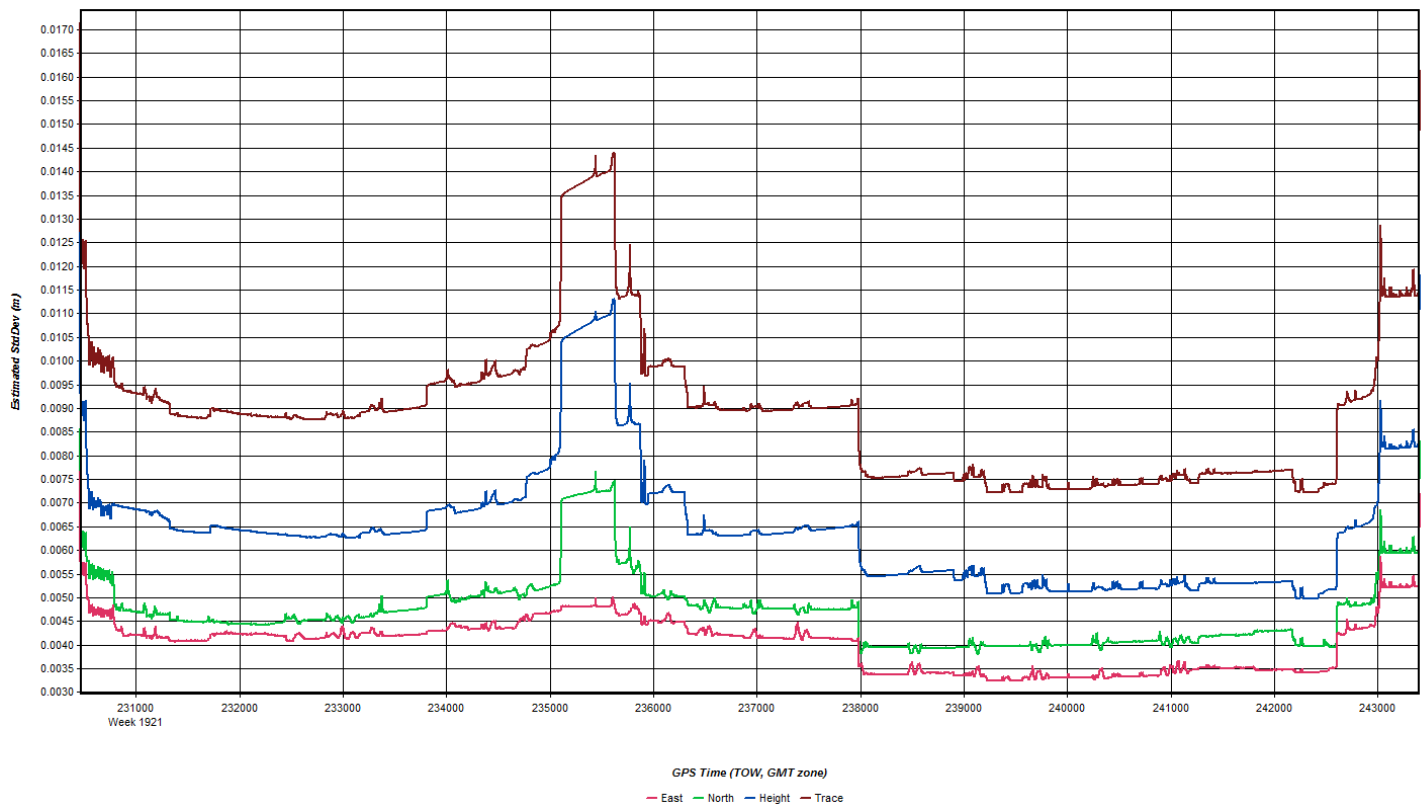

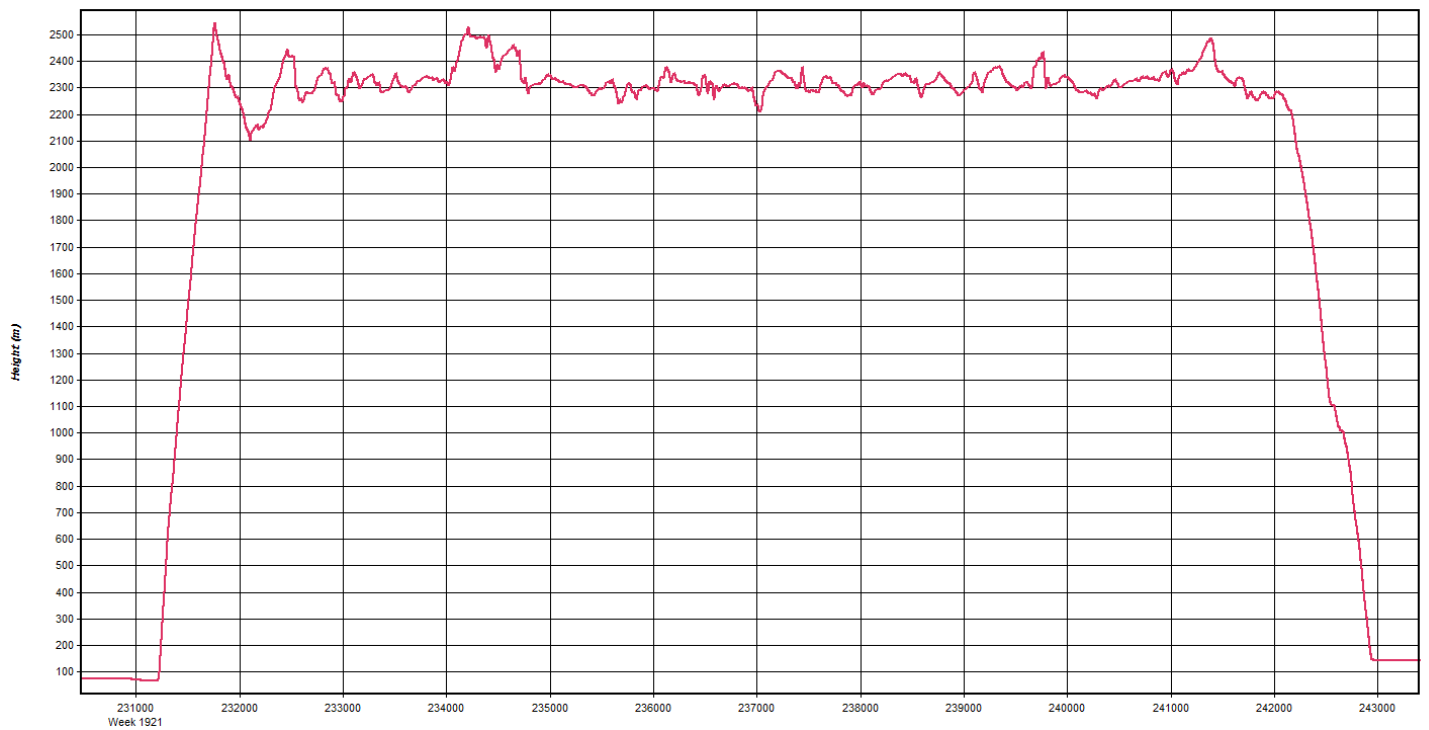
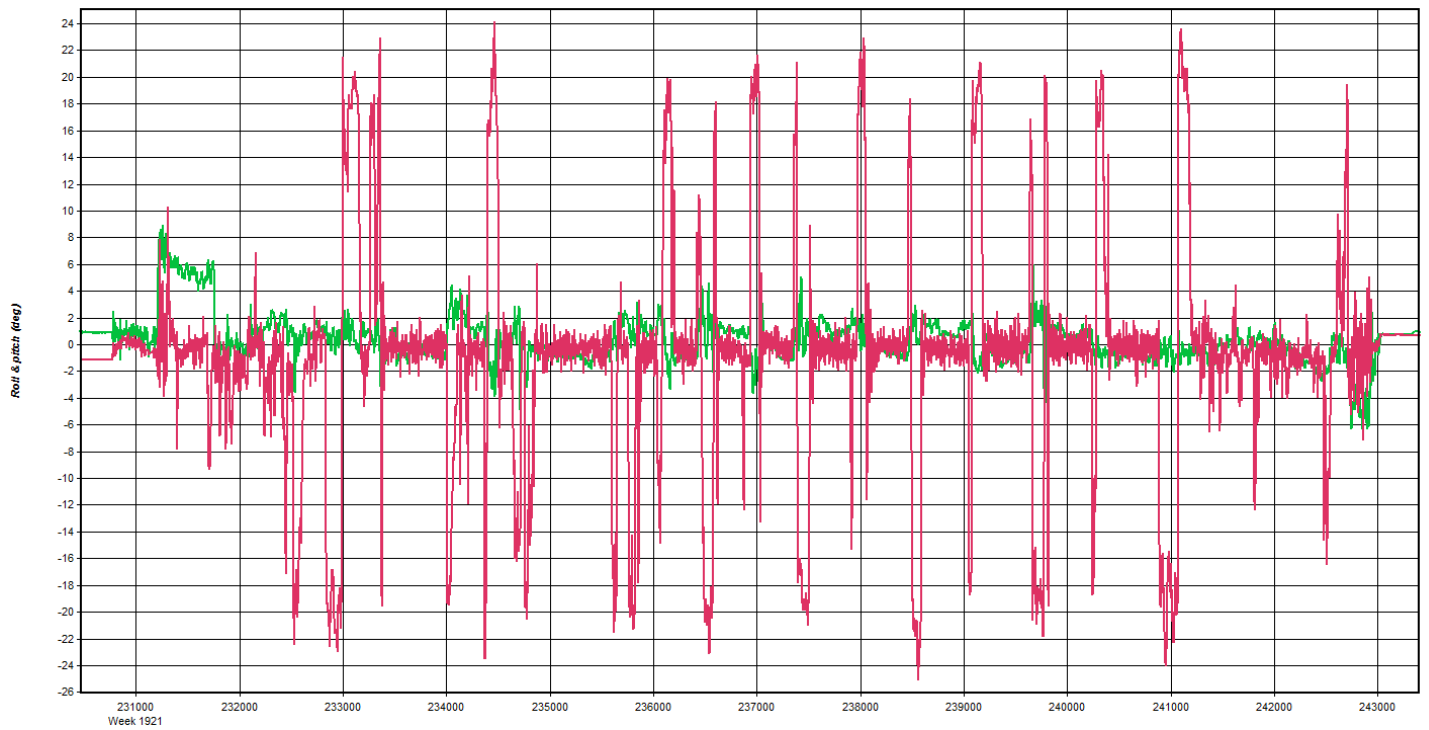

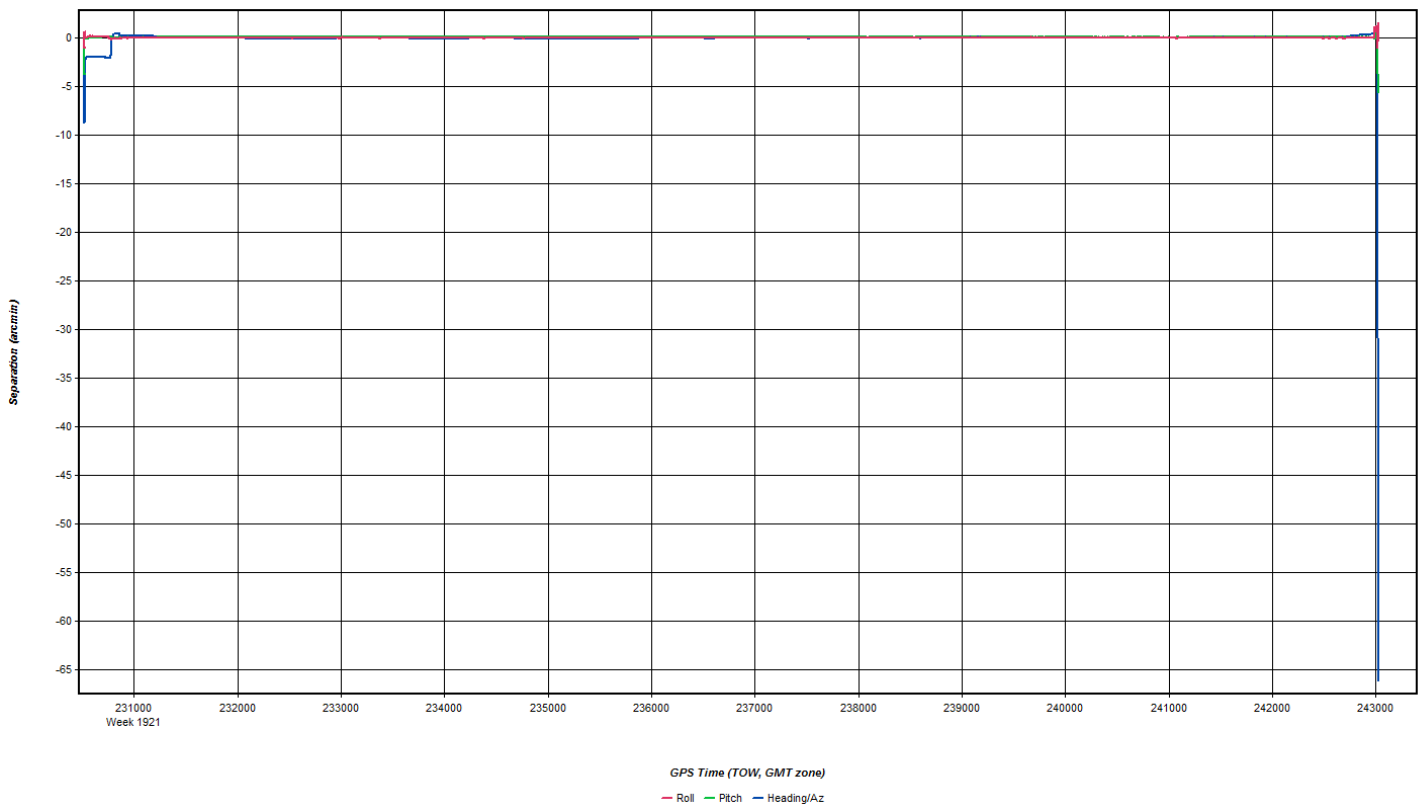
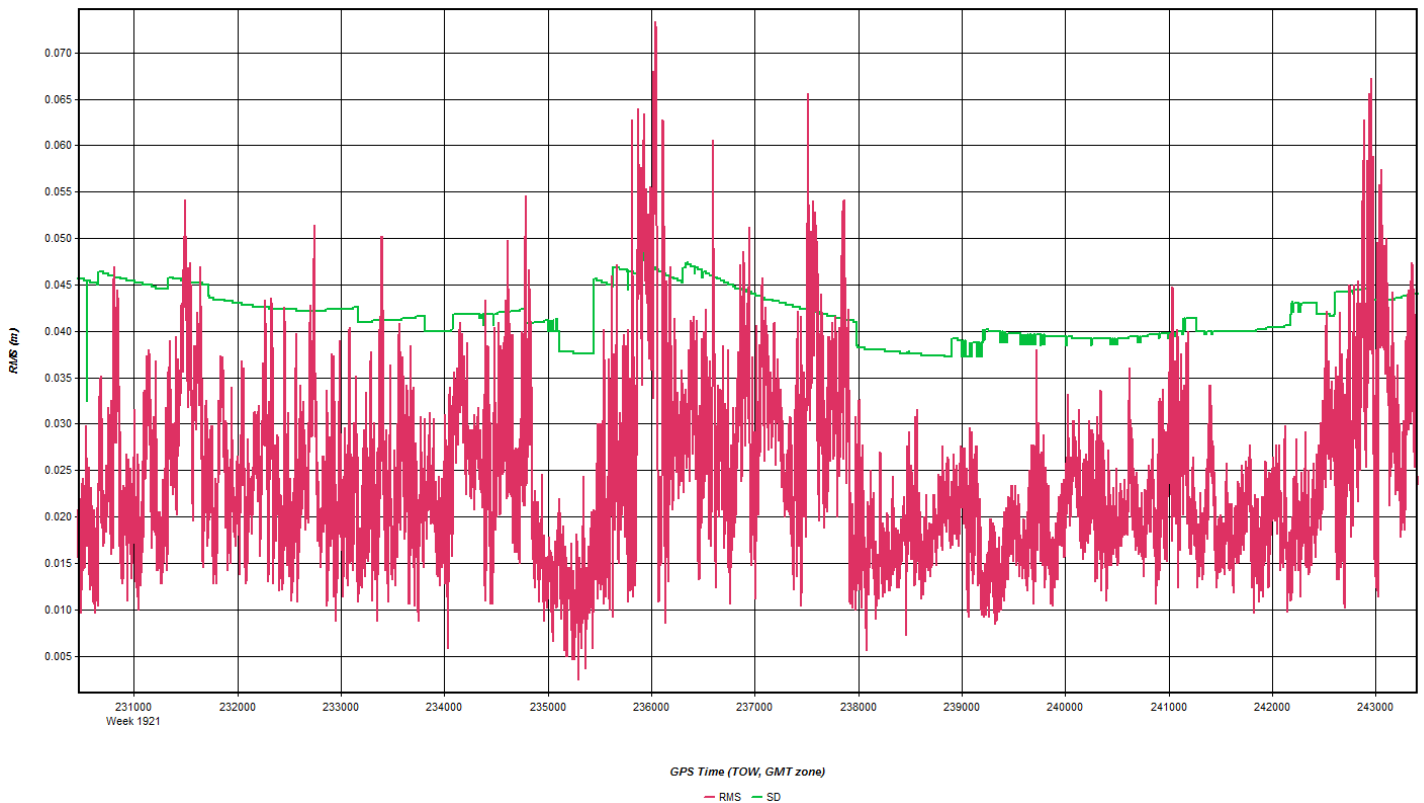

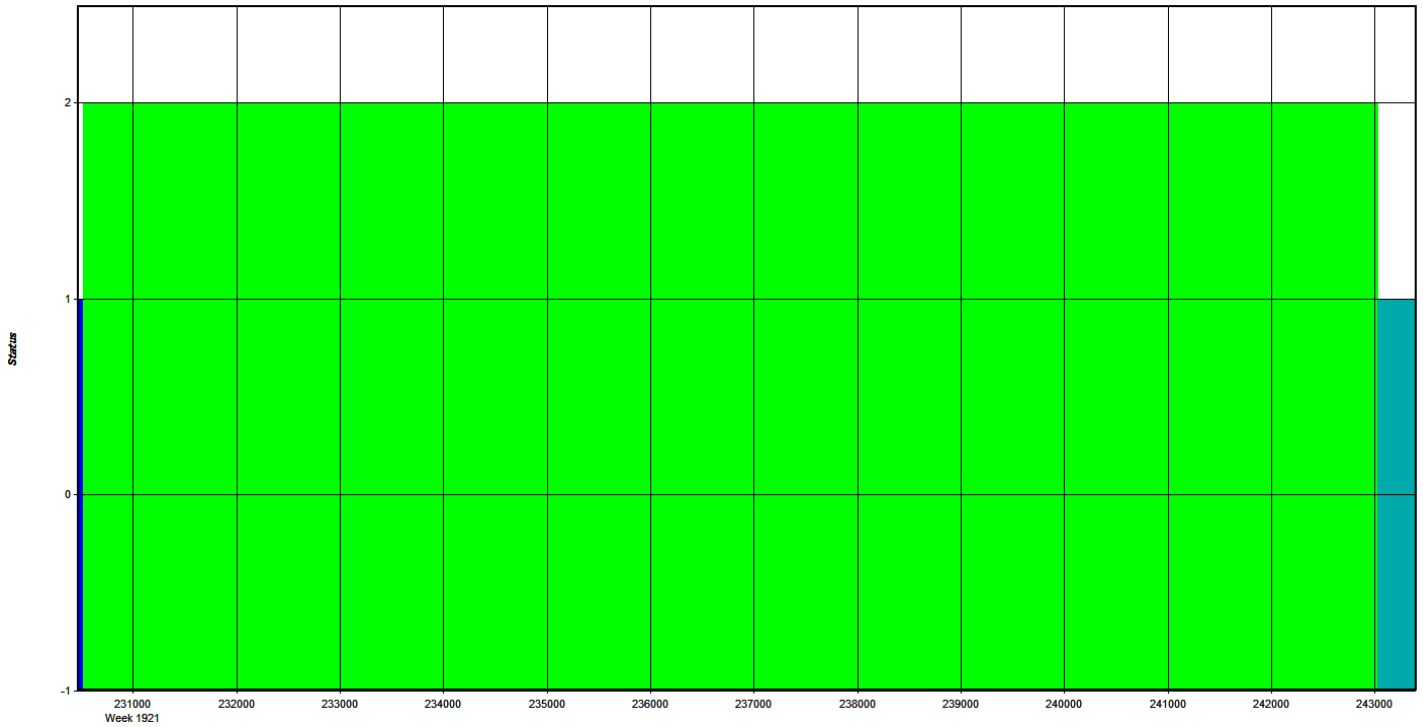

GPS Time (TOW, GMT zone)
 - Float - Forward Fixed - Reverse Fixed - Fixed (2 or more)

Coordinate/Antenna Settings

Master Remote

Base Station
 1: VTD7 Name: VTD7 Disabled
 File: E:\Proc\29178_VT_CT_River_Basin\20161101_AB_29178_ALS7

Coordinates
 Latitude: North 44 23 52.31066 Compute from PPP
 Longitude: West 72 01 32.39267 Enter Grid Values
 Ellipsoidal height: 166.528 m Enter MSL Height
 Datum: WGS84 Datum Options
 Select From Favorites Add To Favorites Use Average Position

Antenna Height
 From station file: TRM55971.00, NONE View STA File
 Antenna profile: TRM55971.00 Info
 Measured height: 0.000 m
 ARP to L1 offset: 0.067 m
 Applied height: 0.067 m
 Measured to:
 ARP
 L1 Phase Centre
 Compute From Slant

OK Cancel

Flight Log

Project: USGS CT RIVER BASIN

Project: USGS CT RIVER BASIN

Aircraft: N737TM

Dep Apt: 0TV

CORS: 01N

GPS Unit: Y / N

Date: 11-1-16

Flight Mgmt File: 29178_0365-WINDSOR-2016101-1532Z

Pilot: BILLINGTON

Tech: MADDY

Co-Pilot: -

Altitude: 1610

Altitude: 1610

Altitude: 1610

Gd Temp beg:		°C		OAT beg:		°C		End:		°C		Altimeter begin:		end:		
Type	Serial #	Alt AGL	Alt AMSL	Pulses In Air	MPIA	Alt	Rate	Avg Terr	Max Gspd	Avg Ft Spacing	Power	Mag GB	End GB	Tot GB	Storage Name/#	
LIDAR	A1570	7178	7200	2	2	± 5500'	2604 KHz	± 1100'	155	100%	30	30	59	29	7178 5504	
	FOV	40°	53Hz													

Line #	Hdg	Start UTC	End UTC	Gd Spd	Power/Batt	GPS Altitude	Crab	Turn (0-1)	Notes
3011	021	1649	1655	164	12/15	7520	0	0	- 4 bit snow miles 2-4 7-17 27-600
3002	201	1704	1705	161	11/16	8180	0	0	
3001	021	1709	1710	163	11/16	7950	0	0	
3080	109	1714	1726	156	10/17	7590	1	0	- TIE LINE FOR LINES 3001,3002,3011
3063	201	1731	1733	156	10/18	7580	0	0	
3062	021	1736	1739	163	10/16	7630	0	0	
3061	201	1743	1747	159	11/16	7530	0	0	
3060	021	1750	1755	160	12/15	7520	0	0	
3059	201	1758	1804	156	13/15	7520	0	0	
3058	021	1807	1813	159	13/16	7470	0	0	
3057	201	1816	1823	151	11/17	7600	0	0	
3056	021	1826	1833	155	12/17	7670	0	0	
3055	201	1836	1843	165	12/17	7570	0	0	
3054	021	1846	1854	156	12/17	7650	0	0	

Total Proj Lines:	Lines Flown: 14	Lines Remain:	Online Time: 2.0	Mob Time:	Notes:
-------------------	-----------------	---------------	------------------	-----------	--------

Nov 7, 2016-A (N22GE, SN7161)

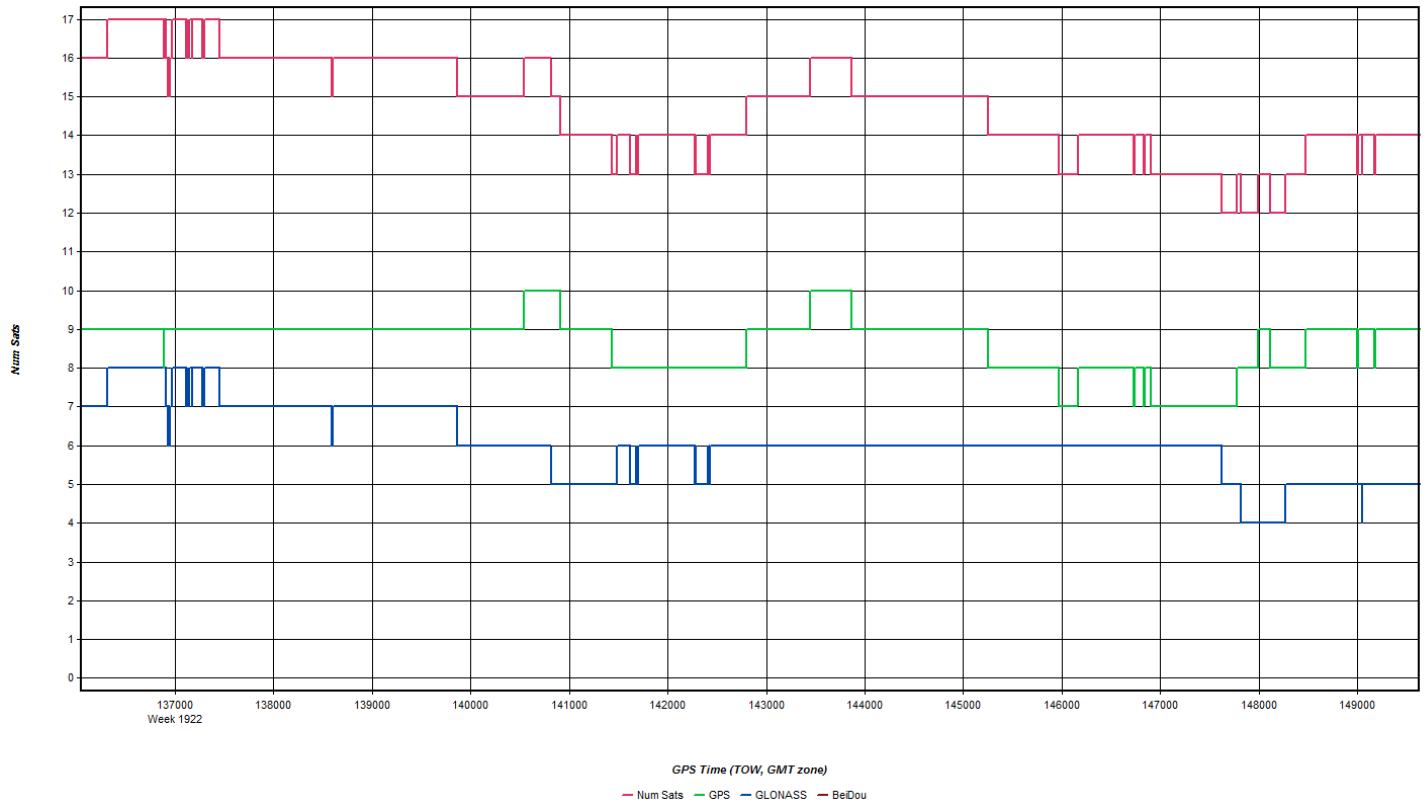
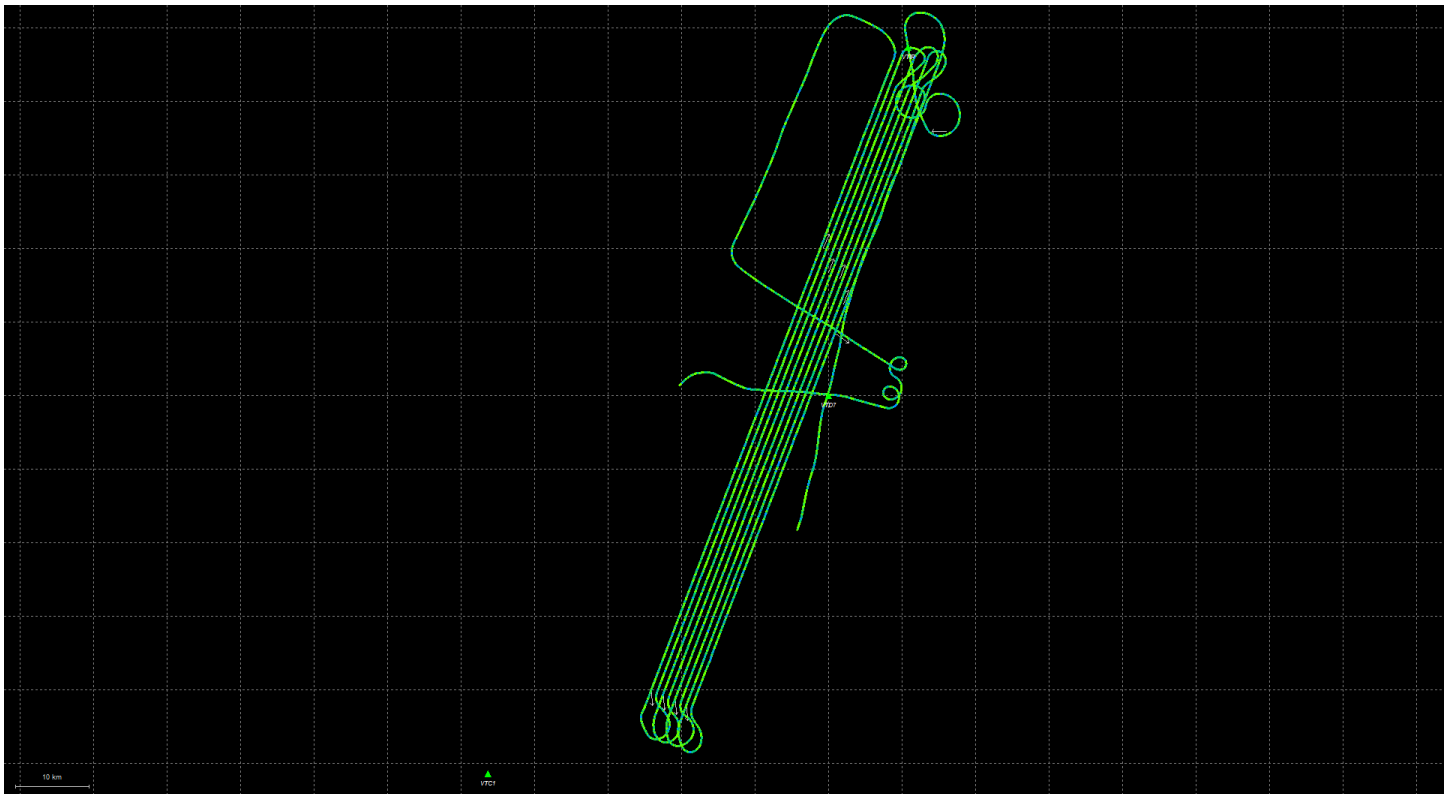

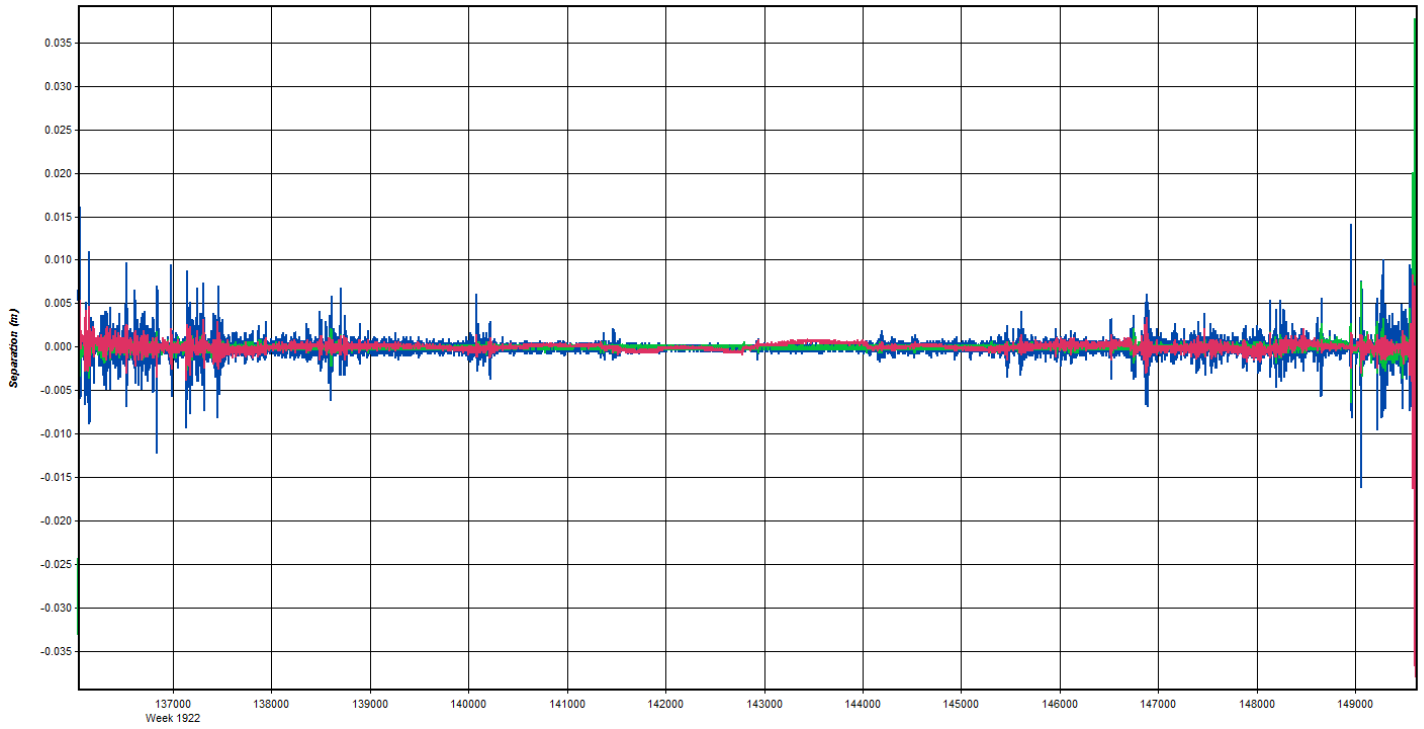

GPS Time (TOW, GMT zone)
— East — North — Up

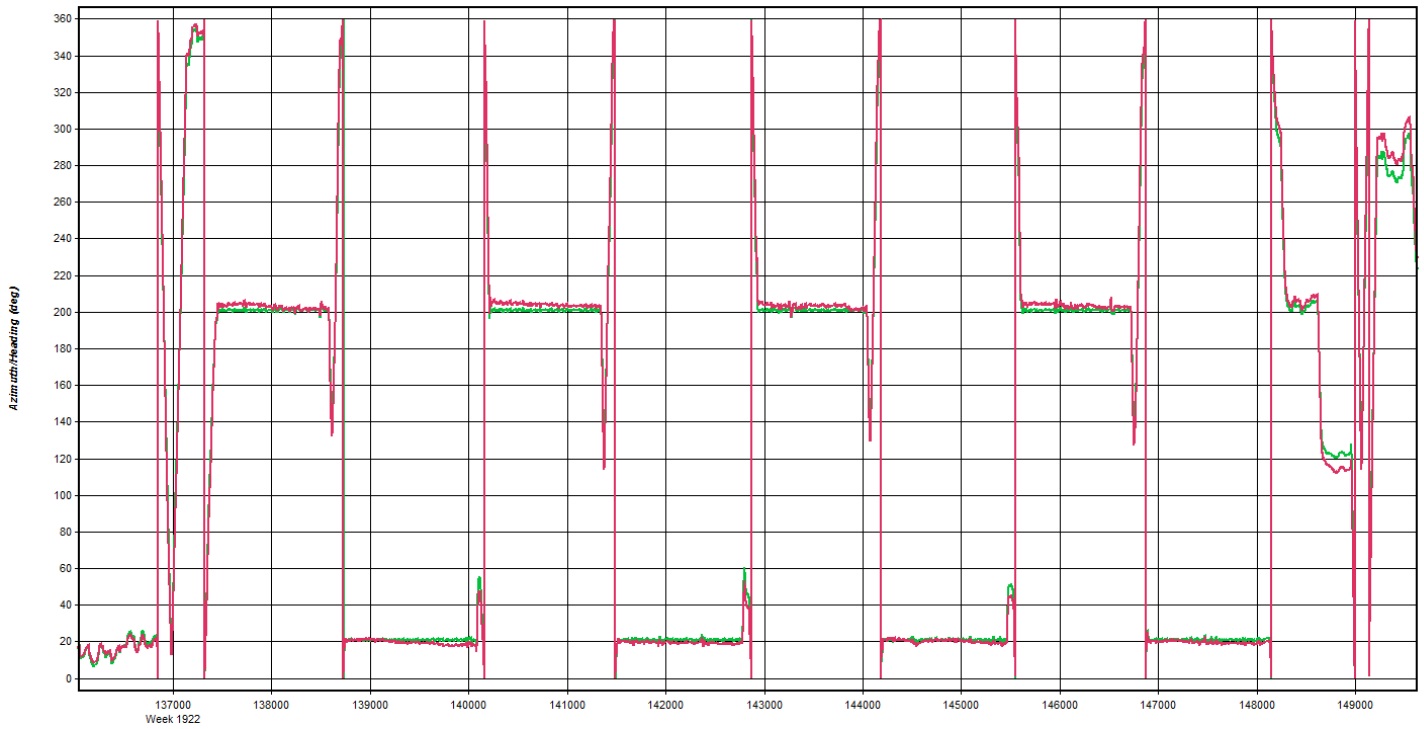

GPS Time (TOW, GMT zone)
— Heading/Azimuth — GPS-COG

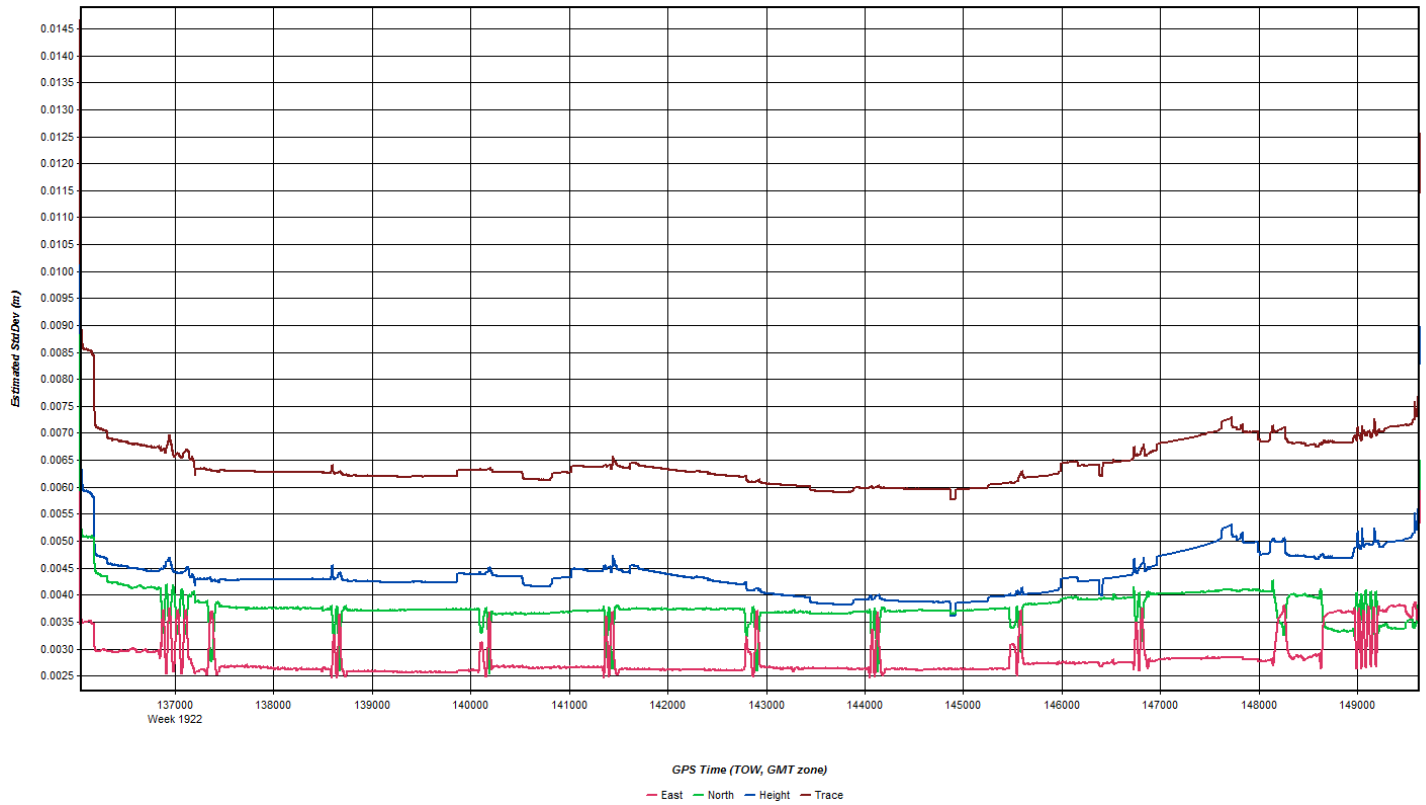
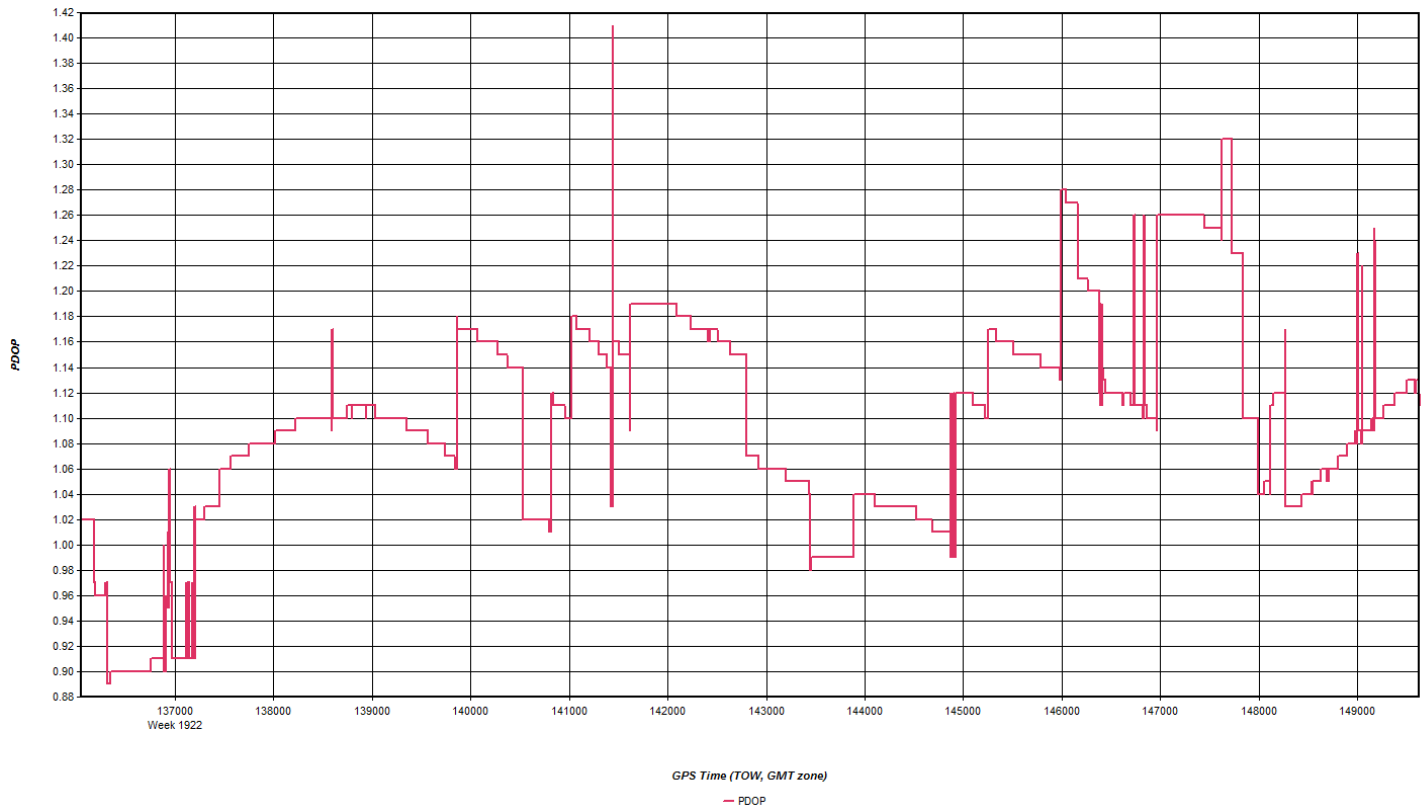

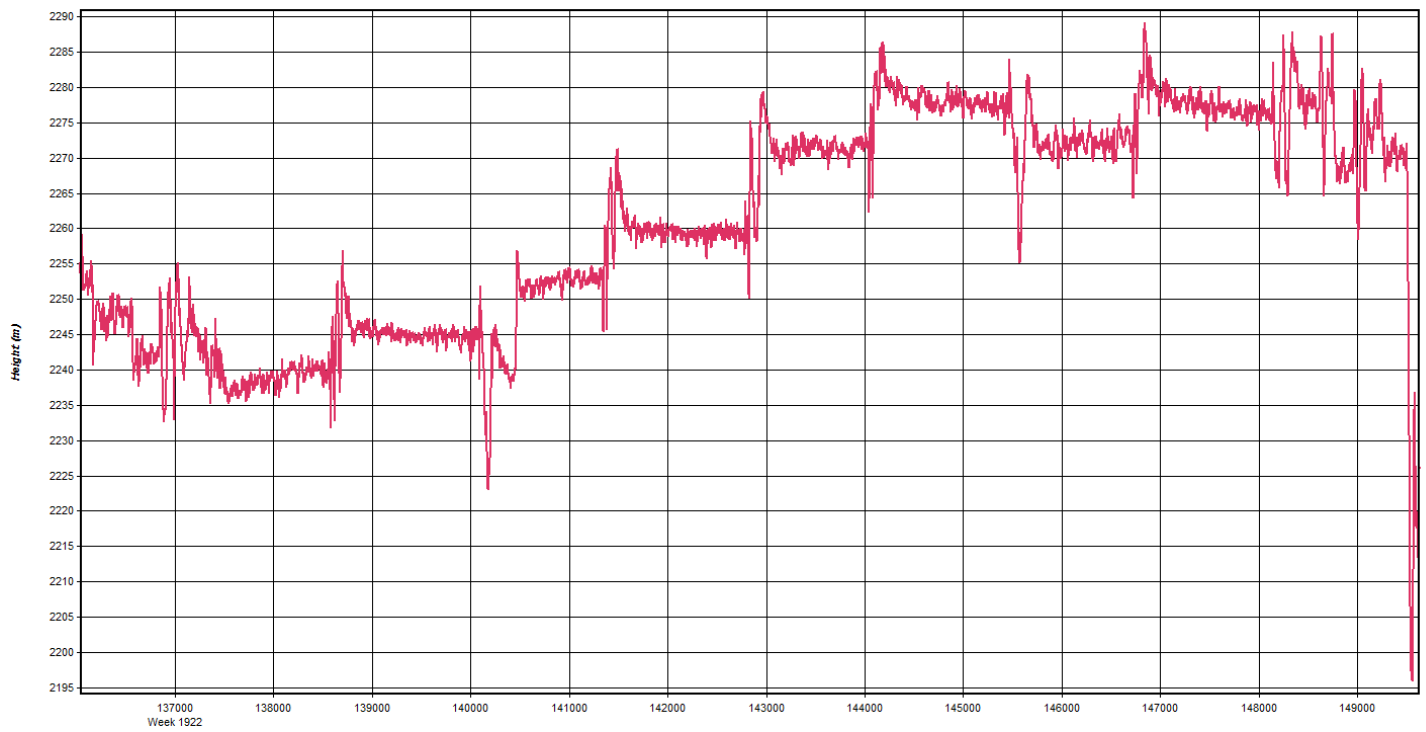
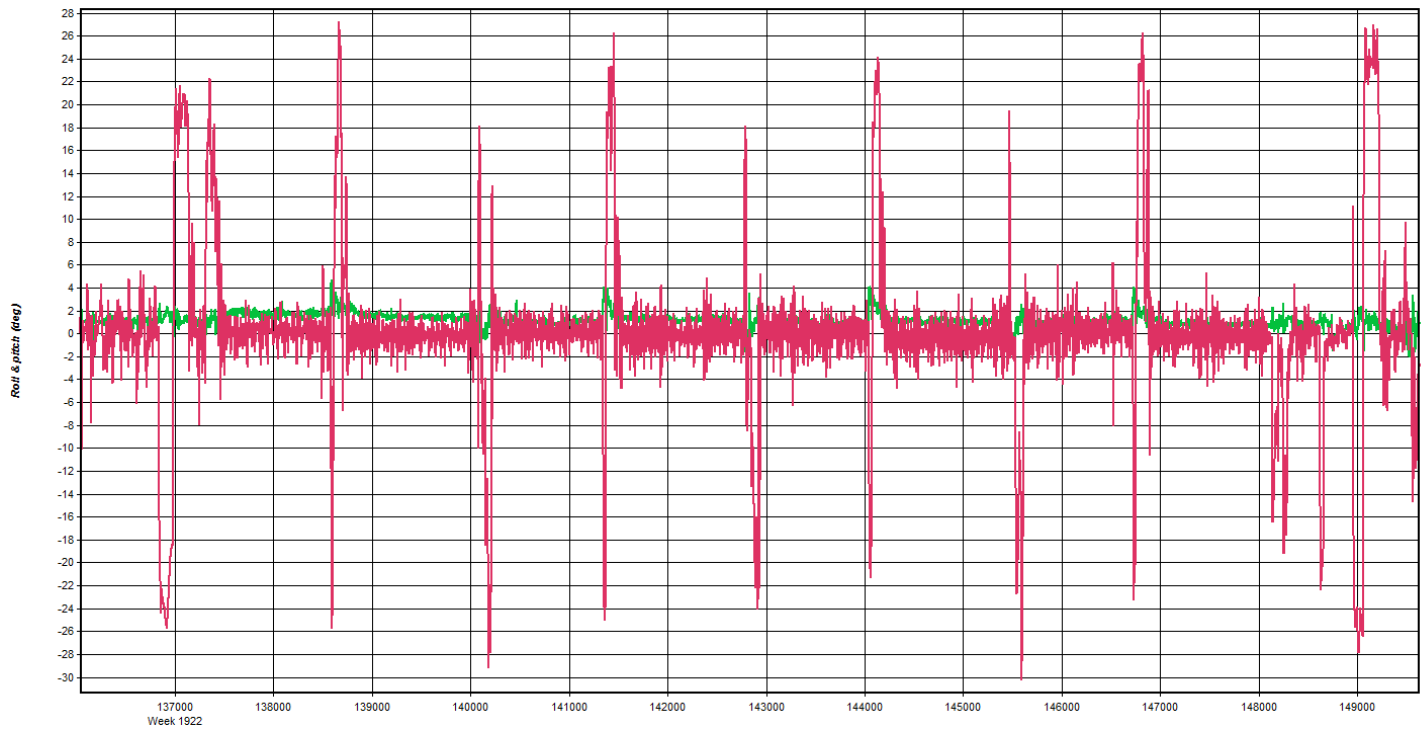

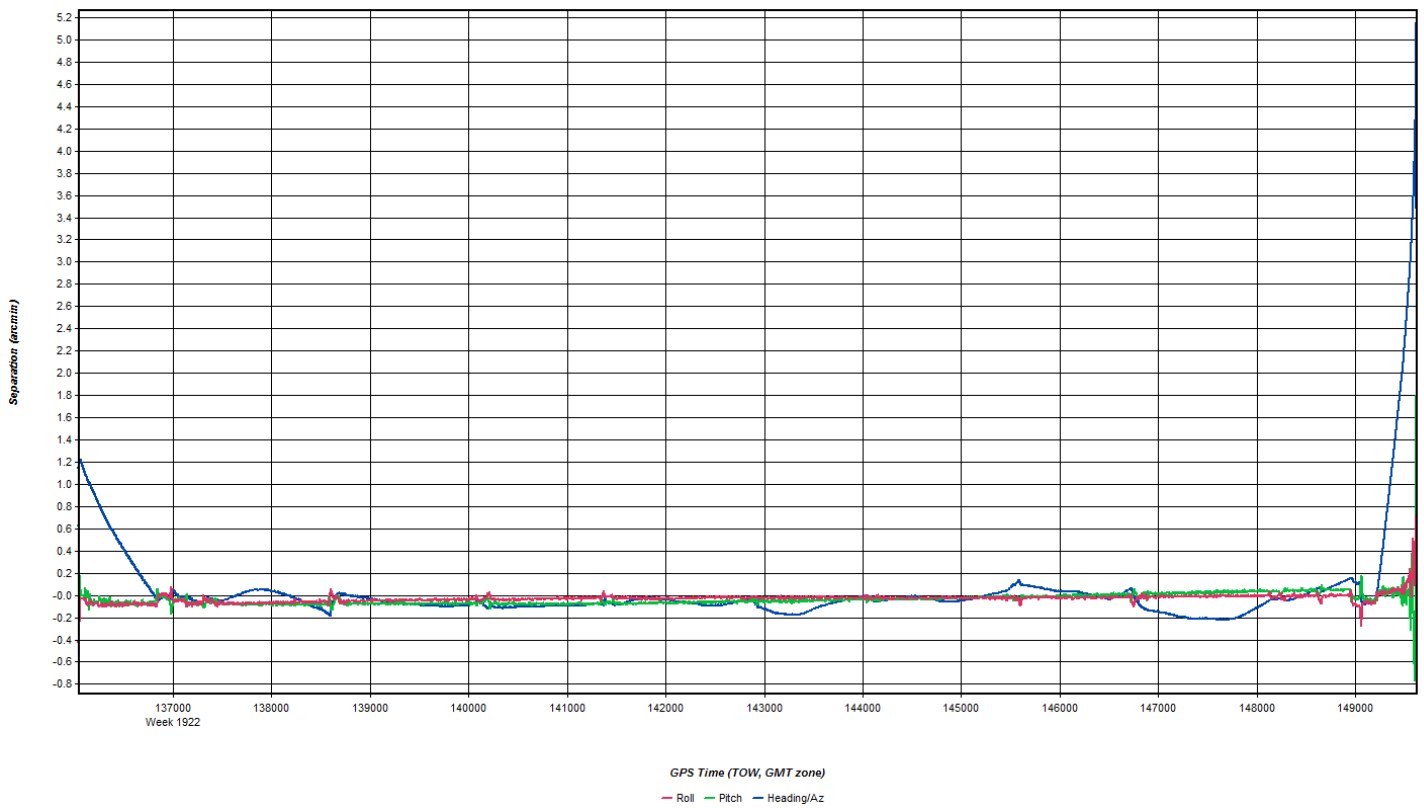
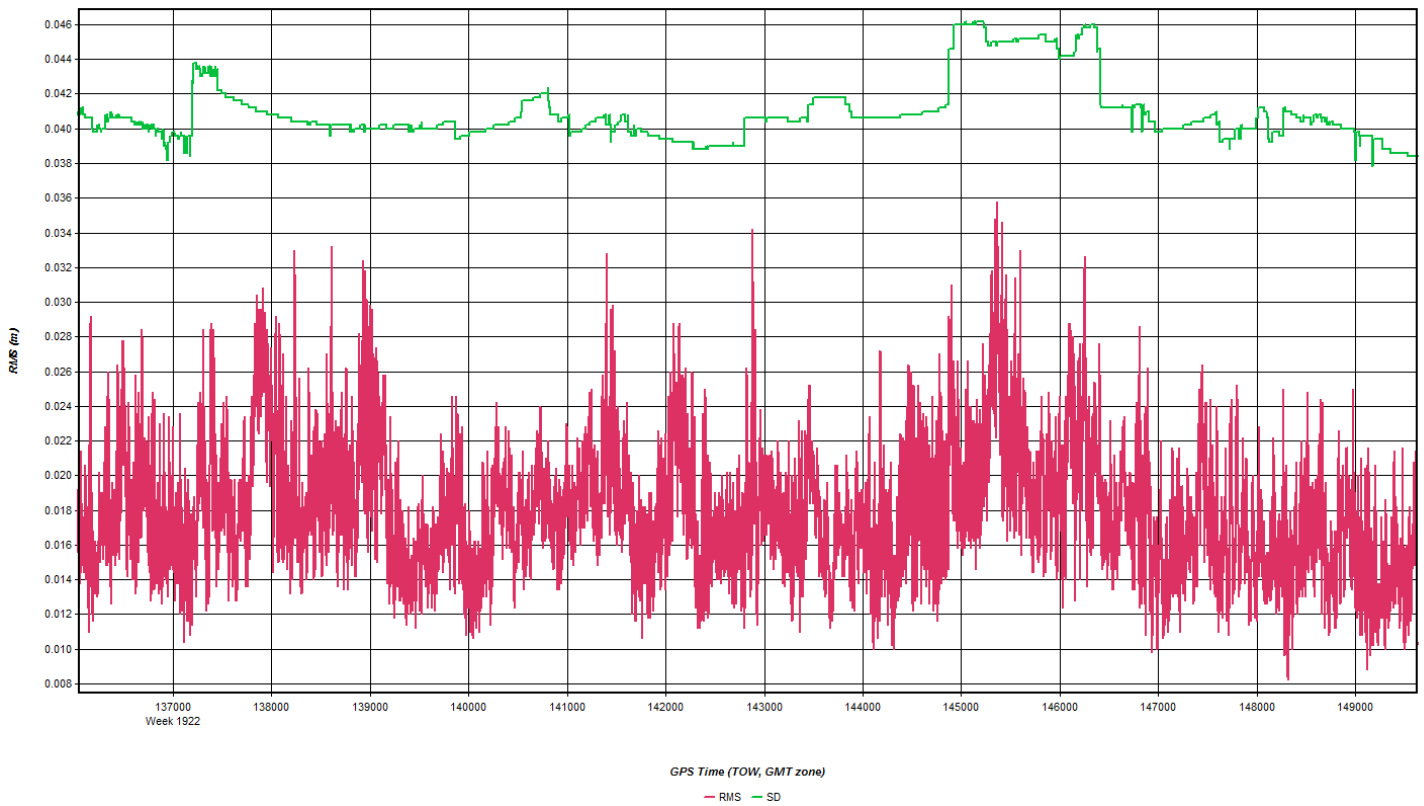

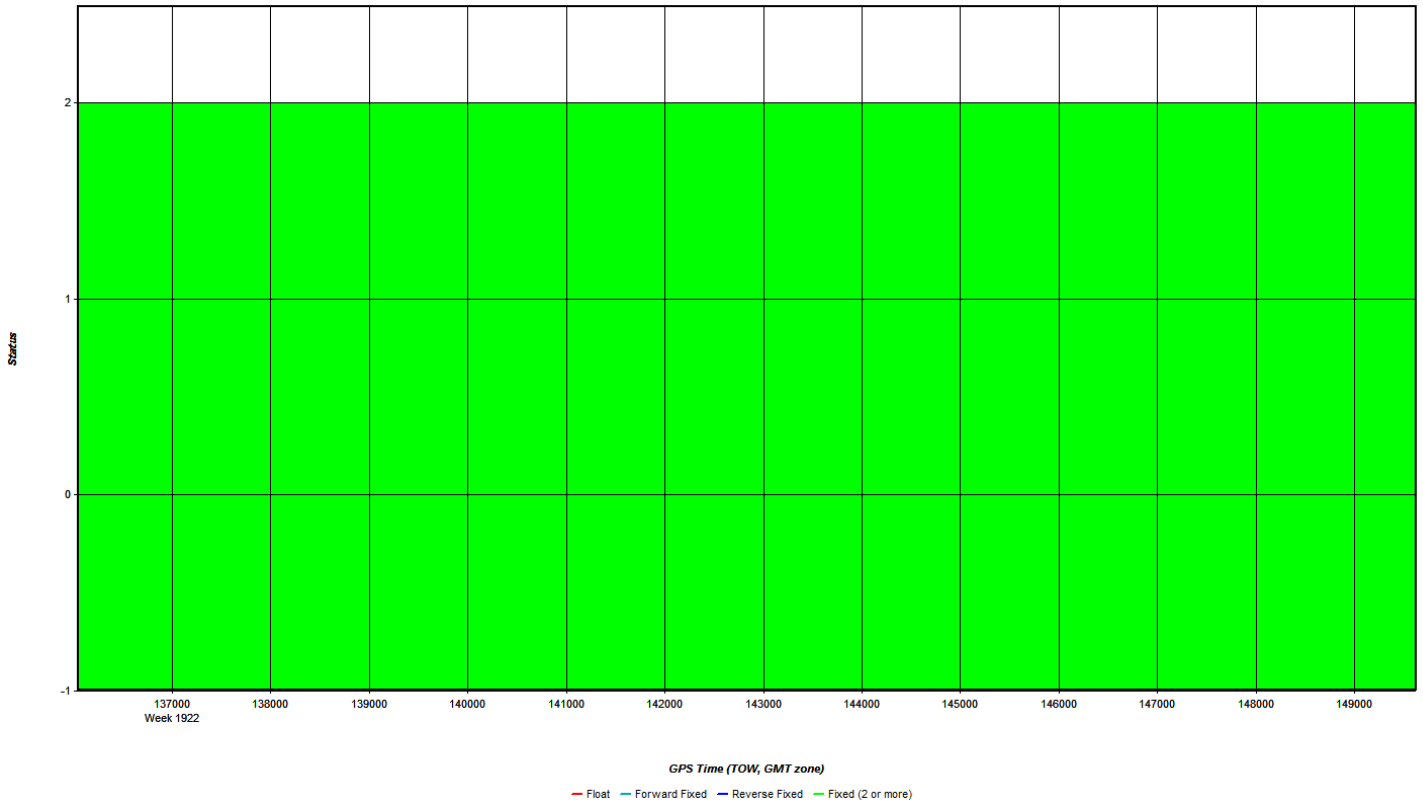

Coordinate/Antenna Settings

Master Remote

Base Station
 2: VTC1 Name: VTC1 Disabled
 File: E:\Proc\29178_VT_CT_River_Basin\20161107_A_B_29178_SN7

Coordinates
 Latitude: North 43 56 21.21809 Compute from PPP
 Longitude: West 72 36 12.56537 Enter Grid Values
 Ellipsoidal height: 405.144 m Enter MSL Height
 Datum: WGS84 Datum Options
 Select From Favorites Add To Favorites Use Average Position

Antenna Height
 From station file: TRM55971.00, NONE View STA File
 Antenna profile: TRM55971.00 Info
 Measured height: 0.000 m
 ARP to L1 offset: 0.067 m
 Applied height: 0.067 m
 Measured to
 ARP
 L1 Phase Centre
 Compute From Slant

OK Cancel

Coordinate/Antenna Settings
? X

Master
Remote

Base Station

1: VTD7
Name: VTD7
 Disabled

File: E:\Proc\29178_VT_CT_River_Basin\20161107_A_B_29178_SN7

Coordinates

Latitude: North
44 23 52.31066
Compute from PPP

Longitude: West
72 01 32.39267
Enter Grid Values

Ellipsoidal height: 166.528 m
Enter MSL Height

Datum: WGS84
Datum Options

Select From Favorites
Add To Favorites
Use Average Position

Antenna Height

From station file: TRM55971.00, NONE
View STA File

Antenna profile: TRM55971.00
Info

Measured height: 0.000 m

ARP to L1 offset: 0.067 m

Applied height: 0.067 m

Measured to

ARP

L1 Phase Centre

Compute From Slant

OK
Cancel

Coordinate/Antenna Settings
? X

Master
Remote

Base Station

3: VTIP
Name: VTIP
 Disabled

File: E:\Proc\29178_VT_CT_River_Basin\20161107_A_B_29178_SN7

Coordinates

Latitude: North
44 49 12.18043
Compute from PPP

Longitude: West
71 53 25.83872
Enter Grid Values

Ellipsoidal height: 341.732 m
Enter MSL Height

Datum: WGS84
Datum Options

Select From Favorites
Add To Favorites
Use Average Position

Antenna Height

From station file: TRM55971.00, NONE
View STA File

Antenna profile: TRM55971.00
Info

Measured height: 0.000 m

ARP to L1 offset: 0.067 m

Applied height: 0.067 m

Measured to

ARP

L1 Phase Centre

Compute From Slant

OK
Cancel

Flight Log

Airborne LIDAR Data Collection Log Sheet :: Quantum Spatial, Inc
(email log daily to flight_log_distribution_list@quantumspatial.com)

Project: **LIDAR - CT River Basin** Proj #: **29178** Flight Mgmt File: **29178_VEG-5-CTRiverBasin_SNTM16_5550**
 Altcraft: **N27GE** Begin Hobbs: **89417** End Hobbs: **89451** Total: **44** Pilot: **Carl Christy** Co-Pilot: **Tommy Grogan**
 Dep Apt: **KLEB** Dep Time (Ld): **8:29** (Z): **13:29** Arr Apt: **KBTY** Air Time (Local): **12:52** (Z): **17:52** Tot Time Aloft: **4:23**
 CORs: **Y/N** Sta 1: **VD7** Flyovers: **Y/N** # Y, times: **Sta 1** **13:51/17:29** **Sta 2**
 GPS Unit: **Y/N** Sta 1: Flyovers: **Y/N** # Y, times: **Sta 1** **13:51/17:29** **Sta 2** **16:22**

Gd Temp beg:		°C		End:		°C		OAT beg:		°C		End:		°C		Altimeter beg:		end:	
Type	Alt	Wind	Dir	Alt	Wind	Dir	Dir	Alt	Wind	Dir	Dir	Alt	Wind	Dir	Dir	Alt	Wind	Dir	Dir
LIDAR	40°	1570	7161	2000	7400'	155	KT	5160'	155	KT	700	90	2			356			
FLIGHT LINE NOTES - visibility, clouds, embla, partial, etc																			
Line #	Hdg	Start (UTC)	End (UTC)	Alt	GPS Altitude	Crab	Roll	Roll											
		13:48	13:53	146															
		14:00	14:06																
3025	20°	14:11	14:29	159	1217	735	3°	0											
3024	21°	14:33	14:54	128	1316	738	1°	0											
3023	20°	14:58	15:15	154	1117	740	4°	0											
3022	21°	15:19	15:39	135	919	742	1°	0											
3021	20°	15:43	16:00	161	1117	747	4°	0											
3020	21°	16:01	16:24	136	1117	749	2°	0											
3019	20°	16:27	16:45	160	1117	750	4°	0											
3018	21°	16:49	17:08	133	1117	750	1°	-											
42001	122°	17:18	17:22	160	1215	750													
		17:22	17:26																
		17:27	17:31	140															

Notes:
 Flyover of **VD7** **CORS**
 clear, 150' drift to west @ 4 FSE
 clear
 clear
 150' drift to east @ 15 FSE, clear
 200' drift to the west @ 94 FSE
 Clear
 CROSS TIE
 Closeout F18
 Flyover of **VD7** **CORS**

Total Proj Lines: **8** Lines Remain: **N/A** Online Time: **3:2** Mob Time: **1:2** Notes:

Nov 7, 2016-A (N73TM, SN7178)

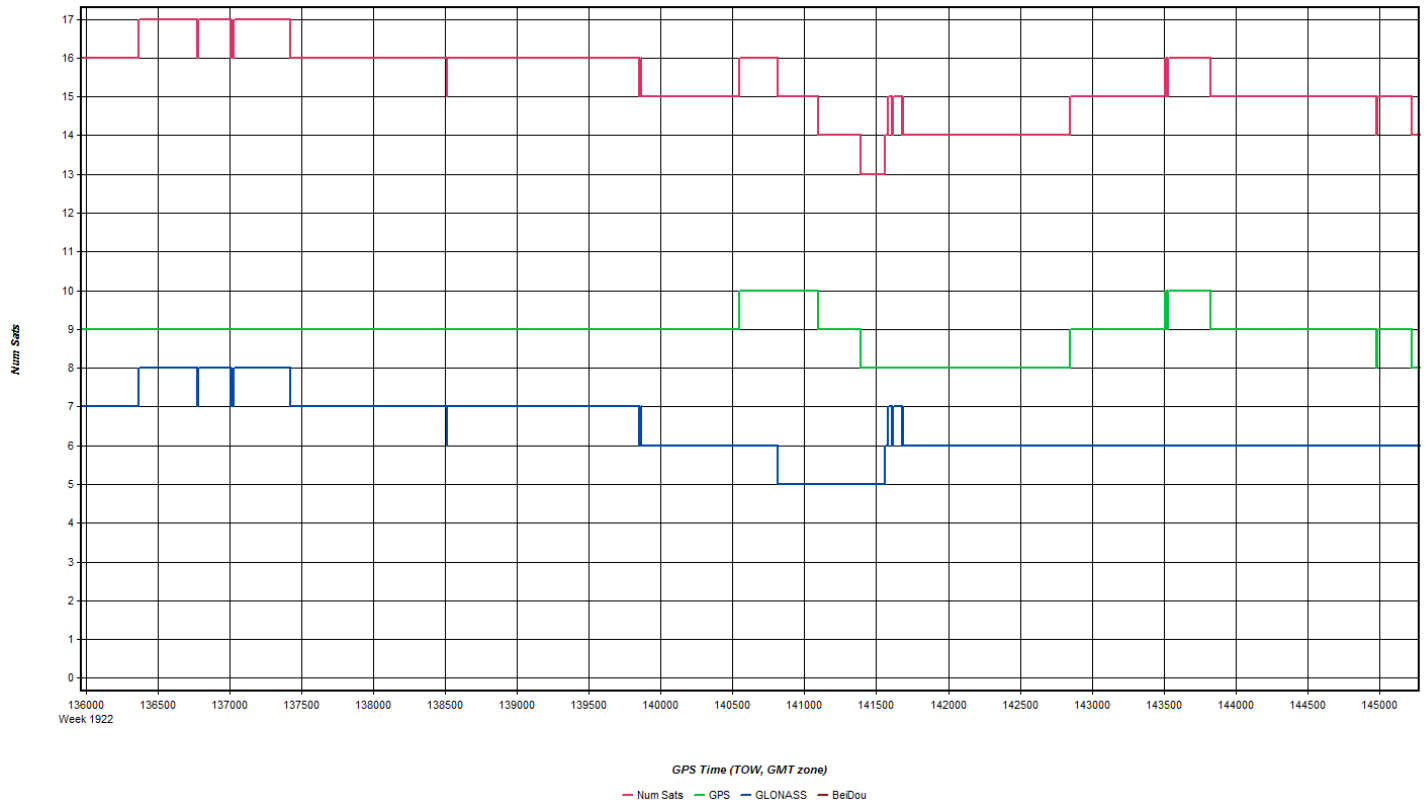
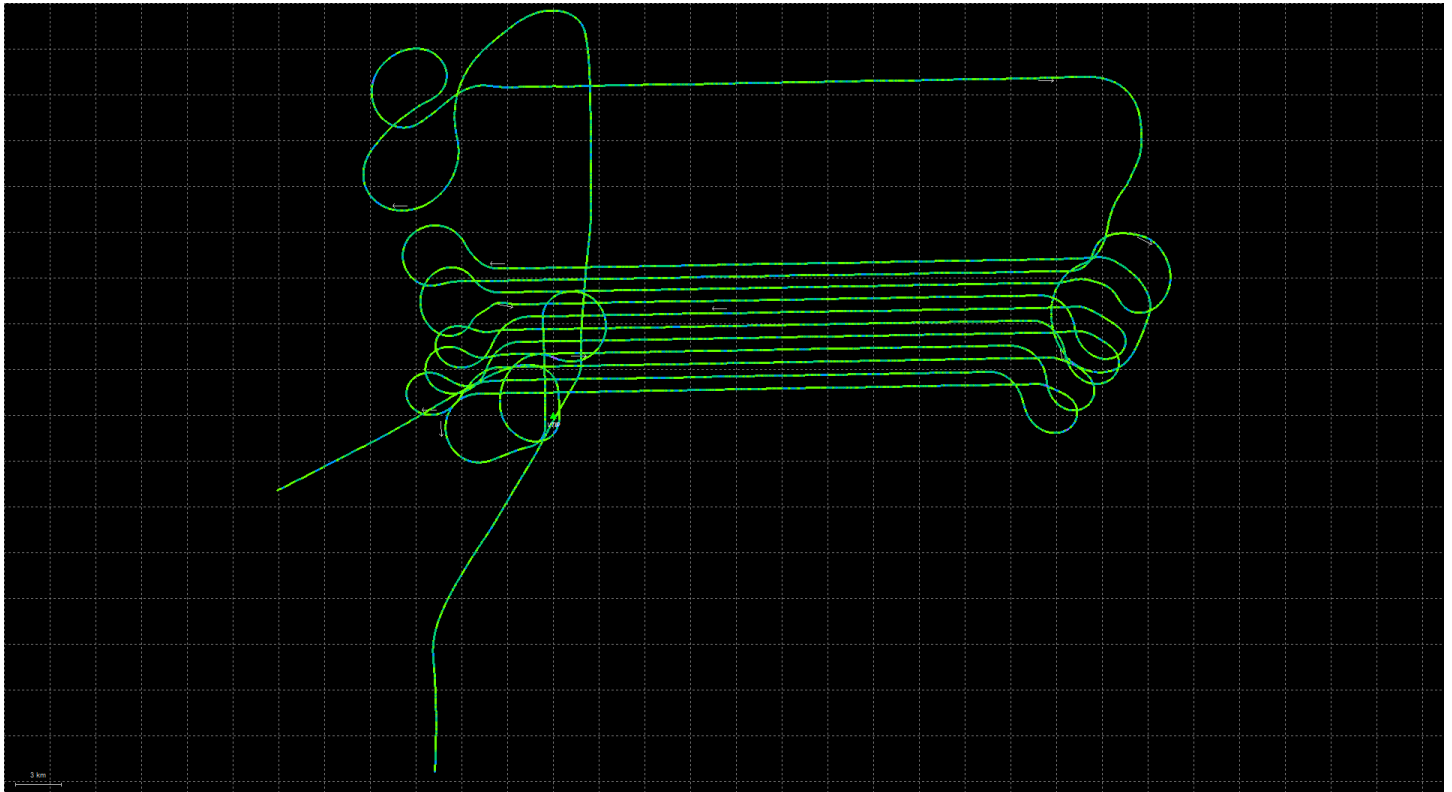

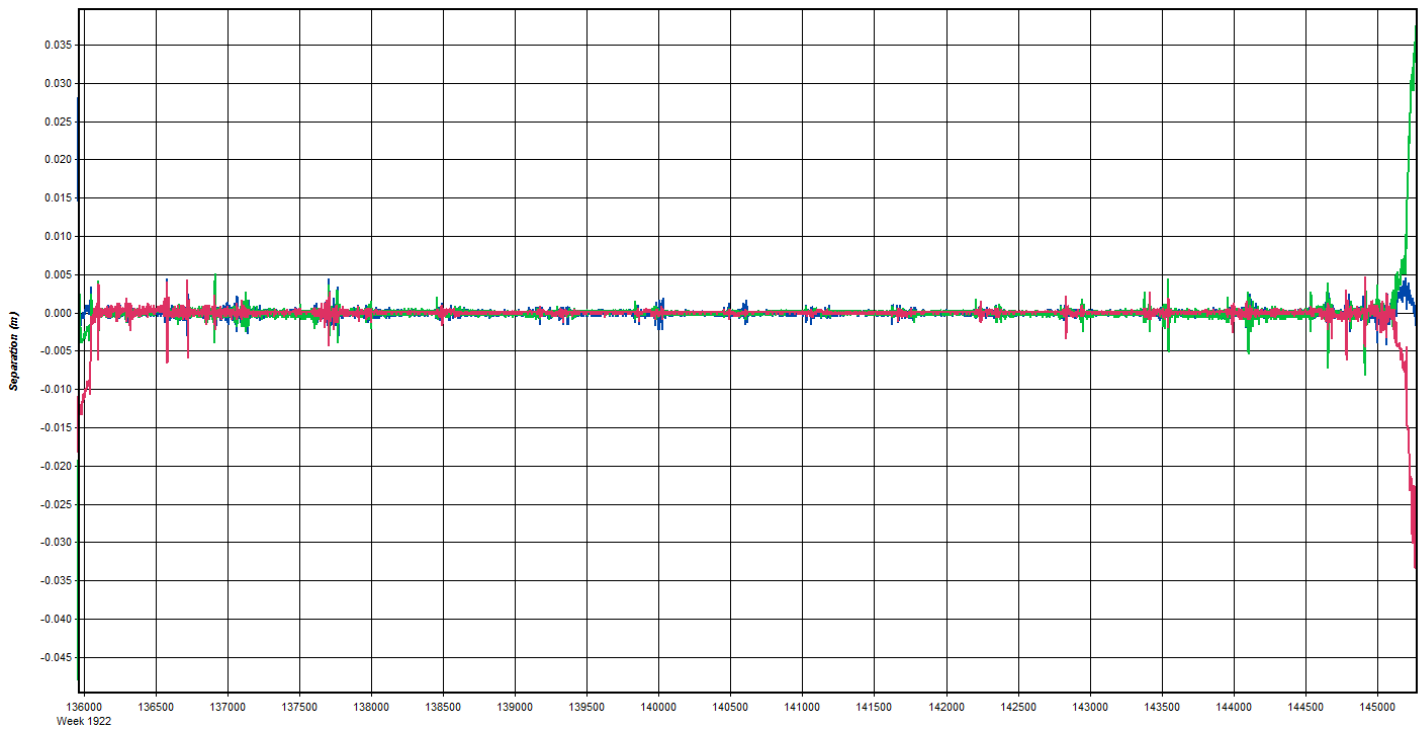

GPS Time (TOW, GMT zone)

— East — North — Up

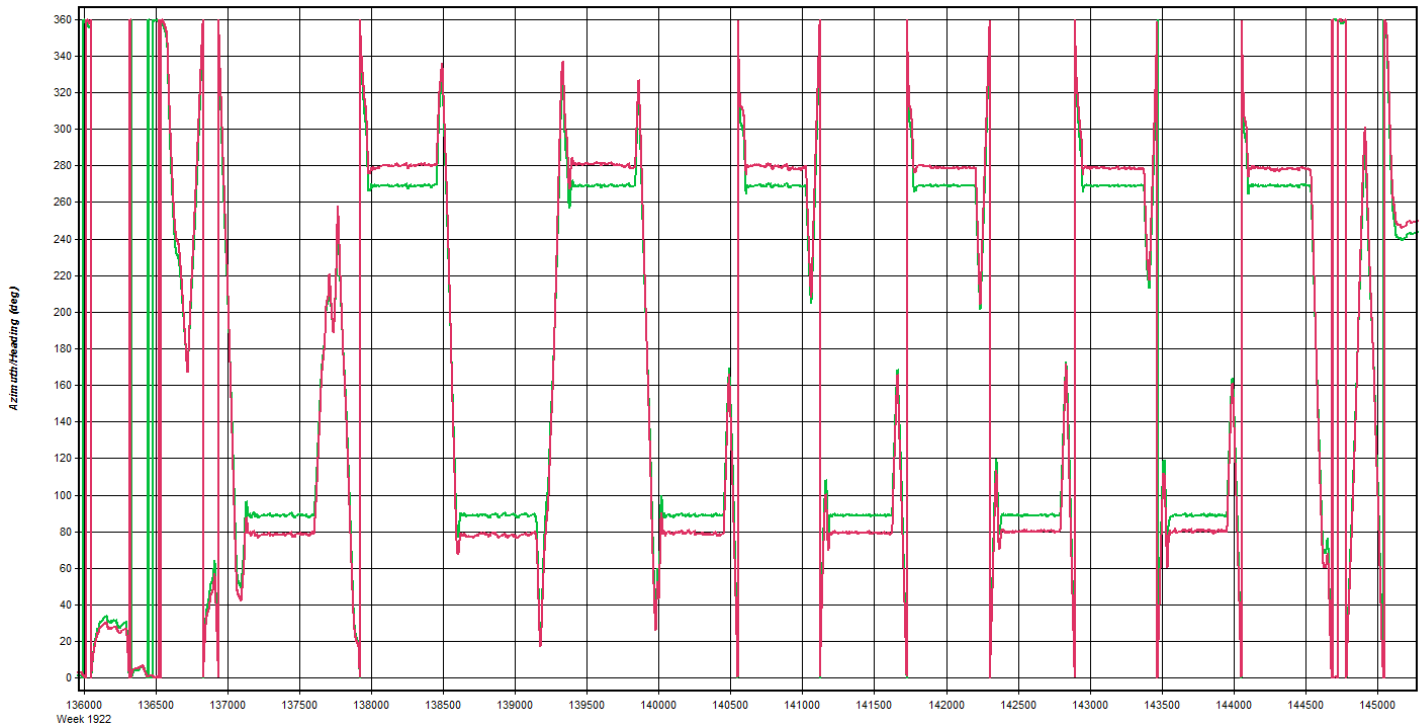

GPS Time (TOW, GMT zone)

— Heading/Azimuth — GPS-COG

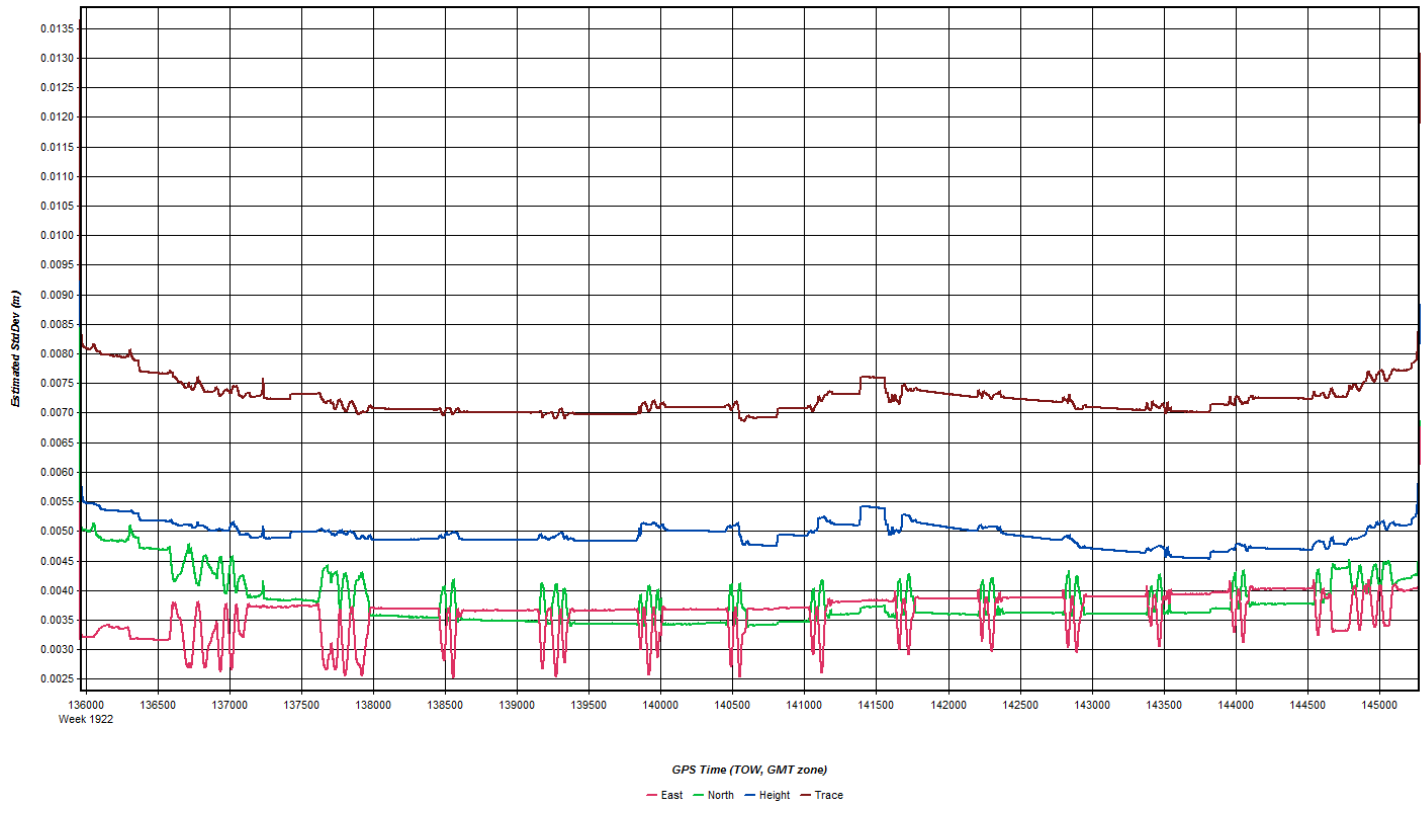

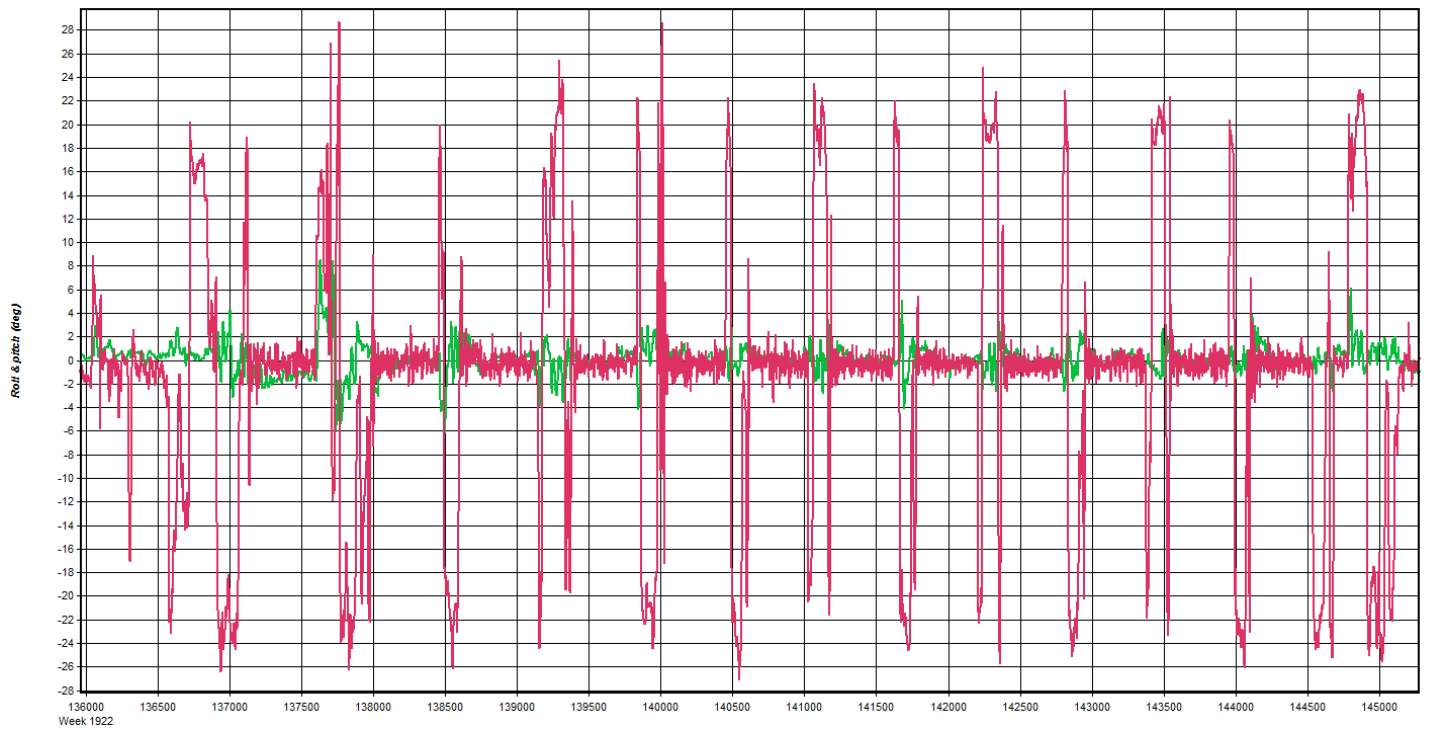

GPS Time (TOW, GMT zone)

— Roll — Pitch

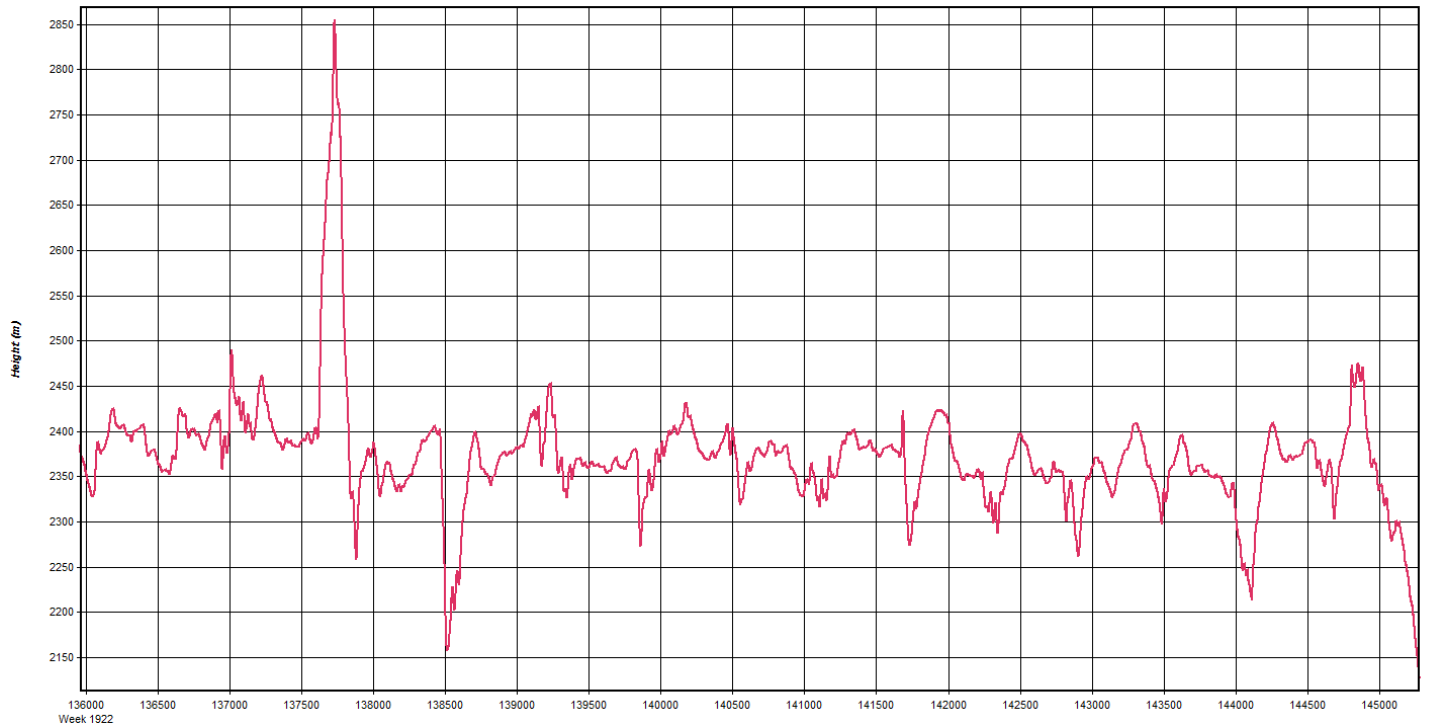

GPS Time (TOW, GMT zone)

— Height

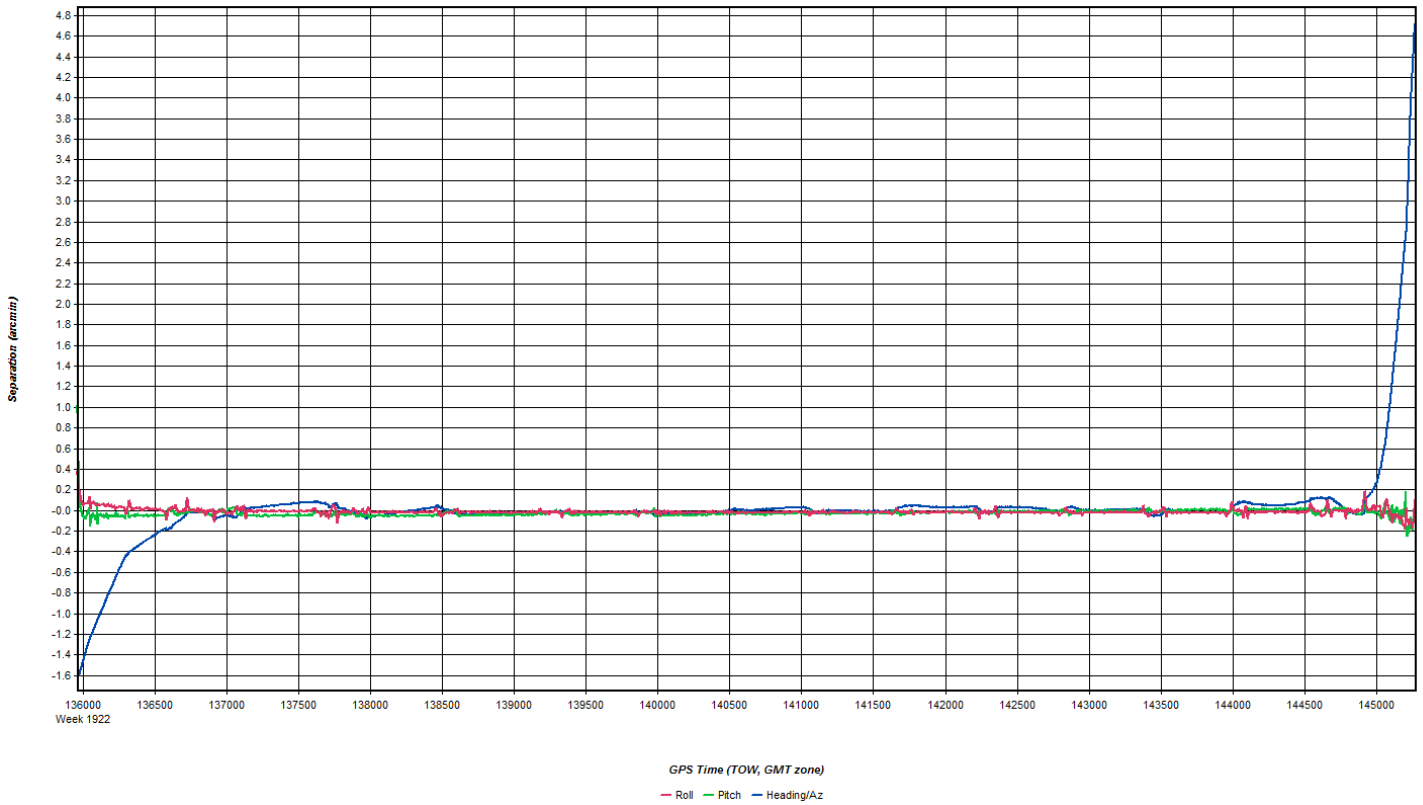
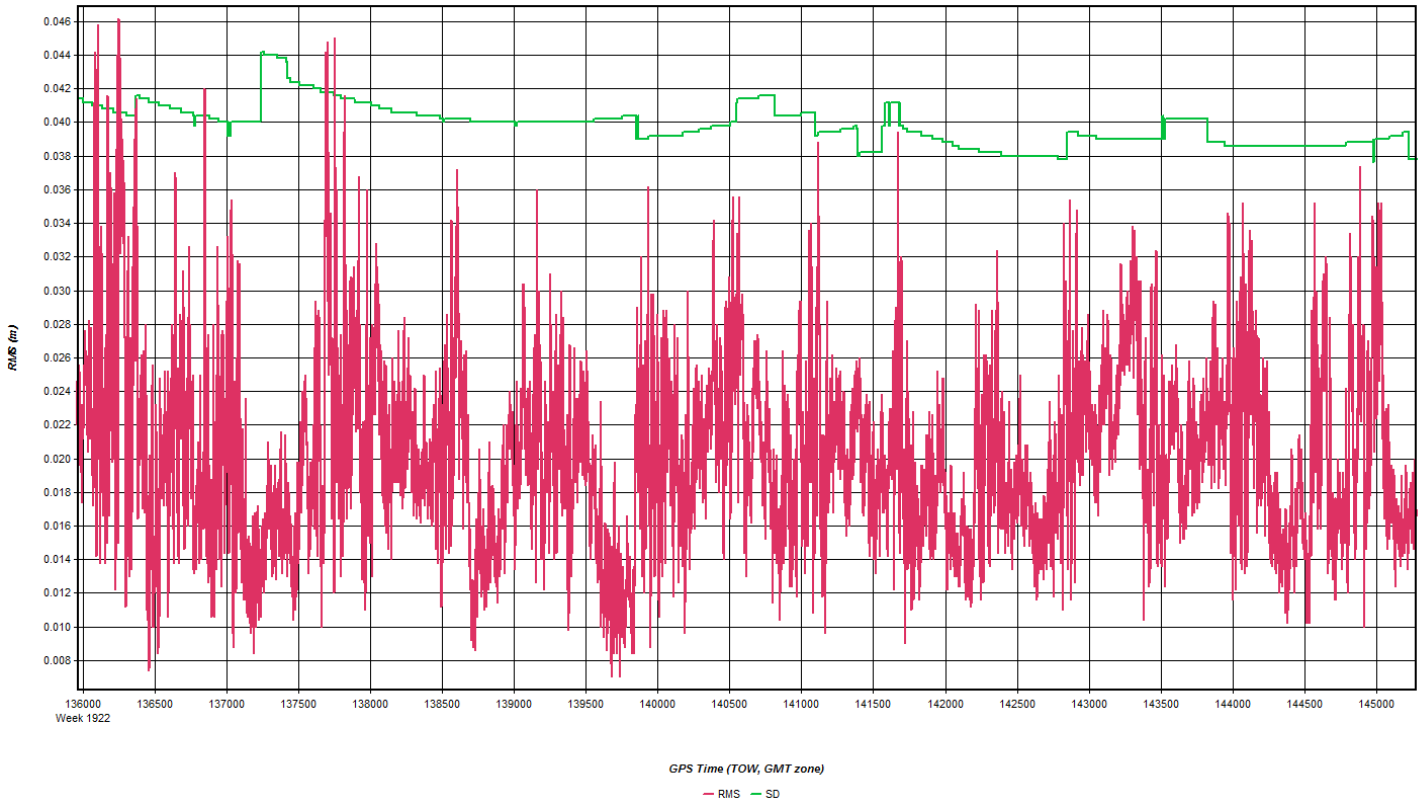

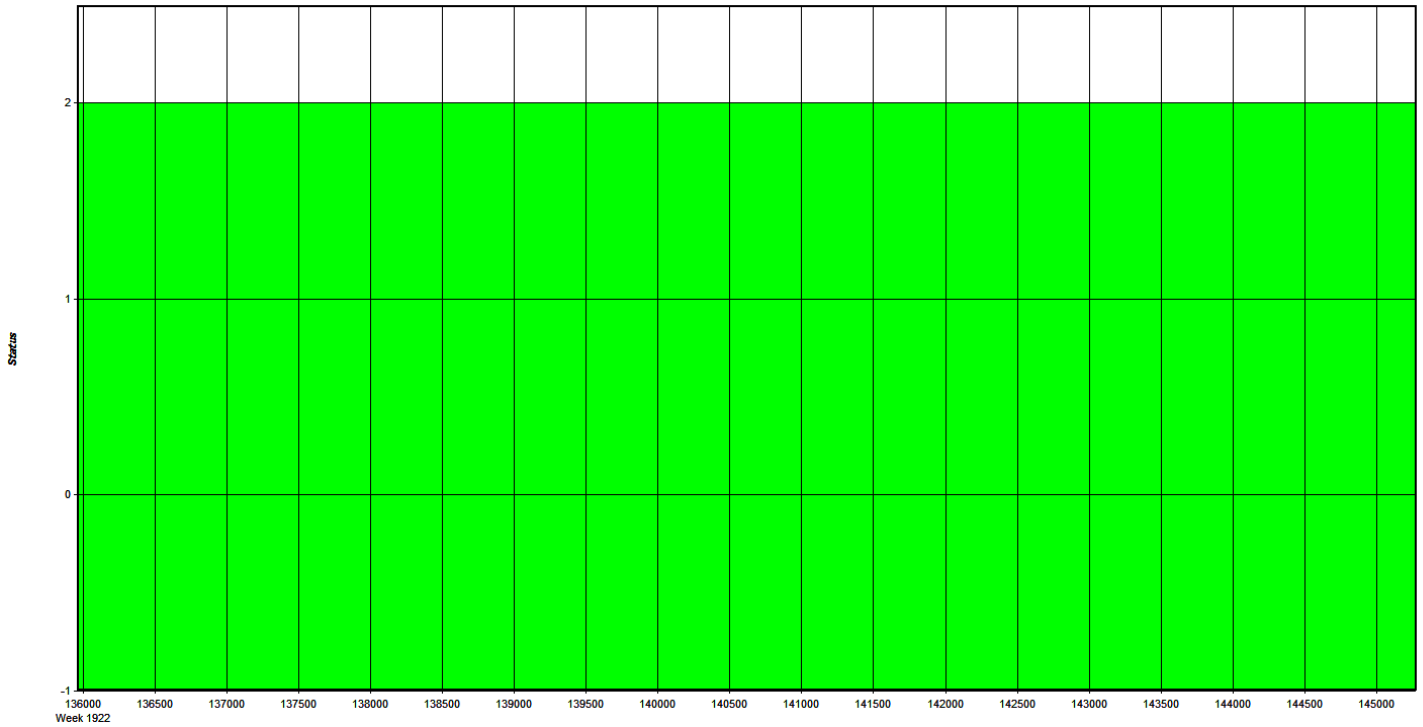

GPS Time (TOW, GMT zone)
 - Float - Forward Fixed - Reverse Fixed - Fixed (2 or more)

Coordinate/Antenna Settings

Master Remote

Base Station
 1: VTIP Name: VTIP Disabled
 File: E:\Proc\29178_VT_CT_River_Basin\20161107_AB_29178_ALS7

Coordinates
 Latitude: North 44 49 12.18043 Compute from PPP
 Longitude: West 71 53 25.83872 Enter Grid Values
 Ellipsoidal height: 341.732 m Enter MSL Height
 Datum: WGS84 Datum Options
 Select From Favorites Add To Favorites Use Average Position

Antenna Height
 From station file: TRM55971.00, NONE View STA File
 Antenna profile: TRM55971.00 Info
 Measured height: 0.000 m
 ARP to L1 offset: 0.067 m
 Applied height: 0.067 m
 Measured to:
 ARP
 L1 Phase Centre
 Compute From Slant

OK Cancel

Flight Log

Scanned by CamScanner

Project: USGS CT RIVER BASIN **Proj #:** 29178 **Date:** 11-7-16 Pg 1 of 1

Flight Mgmt File: 29178_USGS-WINDSOR-5N7178 20161107_130832

Aircraft: N75TM **Begin Hobbs:** 6463.1 **End Hobbs:** 6466.4 **Total:** 3.3 **PILOT:** BULLINGTON **Co-Pilot:** - **Tech:** Moudy

Dep Apt: LEB **Dep Time (Lcl):** 0820 **[Z]:** 1320 **Arr Apt:** BTY **Arr Time (Local):** 1140 **[Z]:** 1640 **Tot Time Aloft:** 3:20

CORS: N S W E **Sta 1:** VTTP **Flyovers:** N S W E **Sta 1:** 1350, 1617 **Sta 2:** -

GPS Unit: Y / N **Sta 1:** - **Flyovers:** Y / N **Sta 1:** - **Sta 2:** -

Gd Temp beg:		°C		End:		°C		OAT beg:		°C		End:		°C		Altimeter begin:		end:	
Type	Altitude	AGL	±	AGL	±	AGL	±	AGL	±	AGL	±	AGL	±	AGL	±	AGL	±	AGL	±
FOV	7178	40°		7178		7900'		7900'		1900'		1900'		155		155		155	
Scan Freq	53Hz			53Hz		2		2		2		2		100%		100%		100%	
Max Gdspd	155			155		155		155		155		155		155		155		155	
Power	155			155		155		155		155		155		155		155		155	

Line #	Hdg	Start [UTC]	End [UTC]	Gd Spd	POOP/s	GPS Altitude	Crab	Turb	FLIGHT LINE NOTES - visibility, clouds, smoke, partial, etc
4001	089	1332	1550	155	11/18	7860	0	0	- MANUAL TIE LINE
4002	089	1405	1413	160	12/17	7980	0	0	- fog 13, 15-16H
4003	269	1419	1427	165	12/17	7660	0	0	- SNOW 12-16, 10, 3-8
4004	089	1430	1438	155	13/16	7800	0	0	- SNOW 3-8, 10, 12-16, 19
4005	269	1443	1450	153	13/16	7780	0	0	- SNOW 19, 13-15, 3-8
4006	089	1453	1500	151	11/17	7850	0	0	- SNOW 3-5, 13-15
4007	269	1503	1510	163	11/17	7740	0	0	- SNOW 12-14, 2-4
4008	089	1513	1520	155	10/19	7720	0	0	- SNOW 2-3, 6, 12-14
4009	269	1523	1529	167	09/19	7780	0	0	- SNOW 13-14, 2-4
4010	089	1533	1539	155	13/17	7740	0	0	- SNOW 2-4, 14
4011	269	1543	1549	153	11/17	7710	0	0	- SNOW 3
4012	089	1552	1558	155	13/17	7760	0	0	
4013	269	1602	1608	153	11/17	7660	0	0	
4014	359	1611	1612	135	11/16	7760	0	0	

Total Proj Lines: _____ **Lines Flown:** _____ **Lines Remain:** _____ **Online Time:** 2:5 **Job Time:** 0:7.5 **Notes:** _____

Nov 7, 2016-B (N22GE, SN7161)

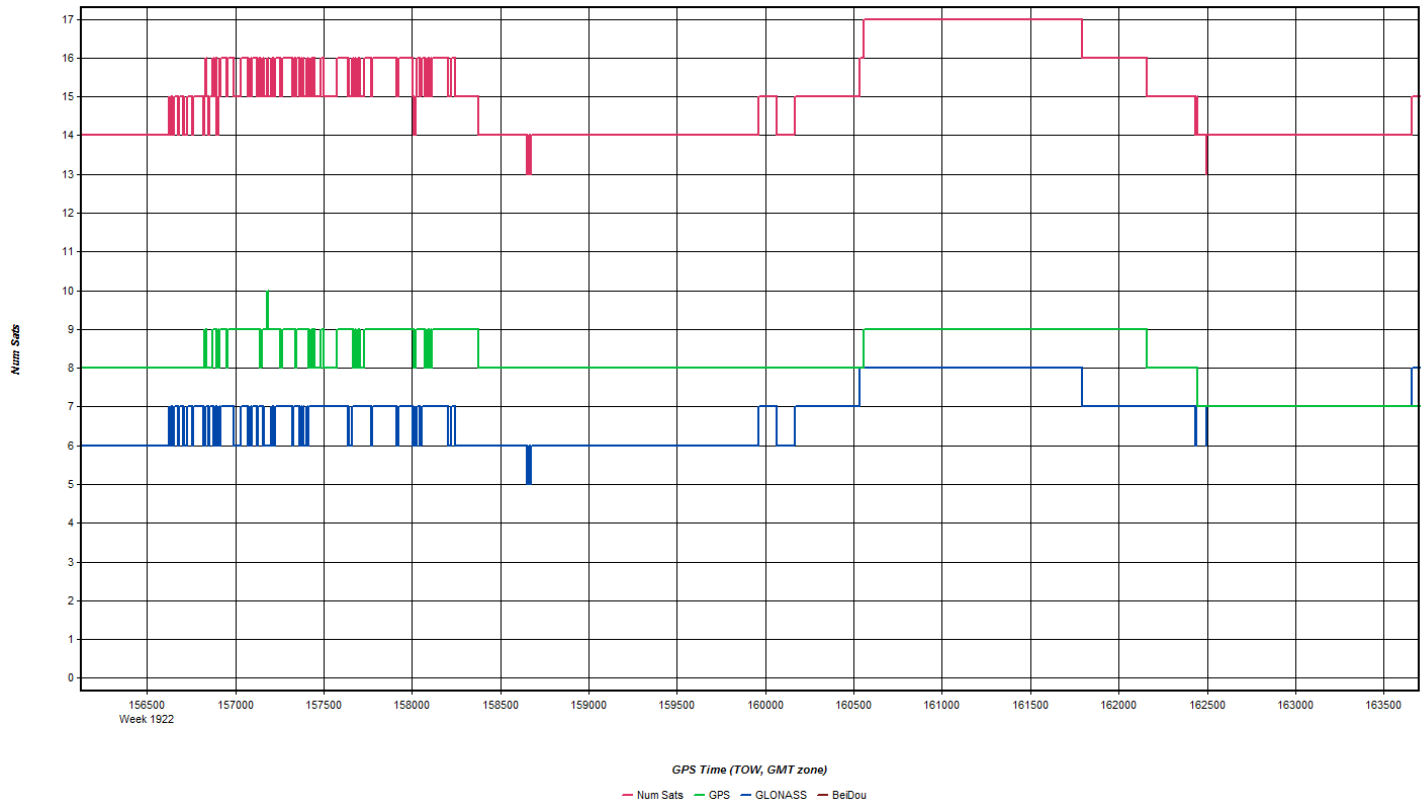
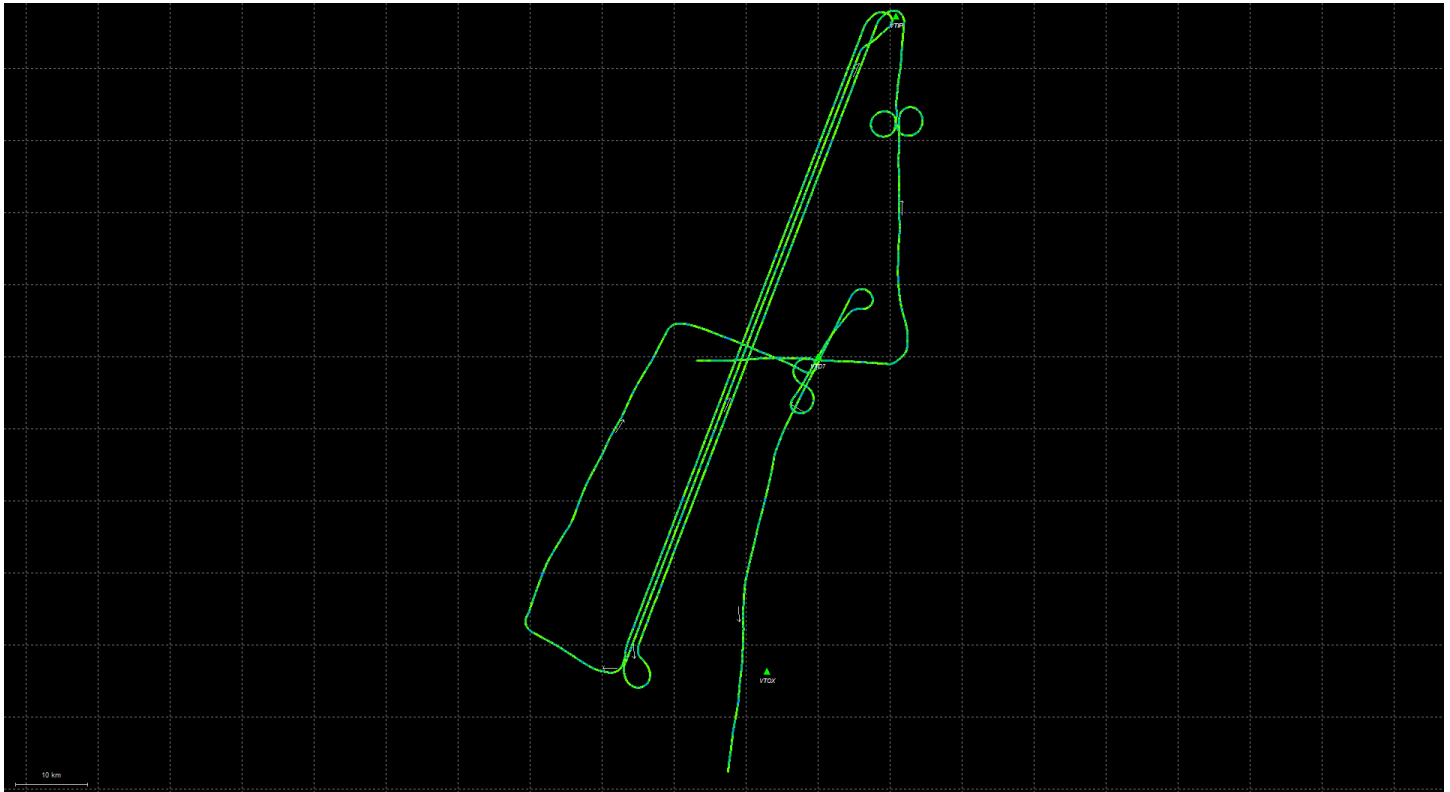

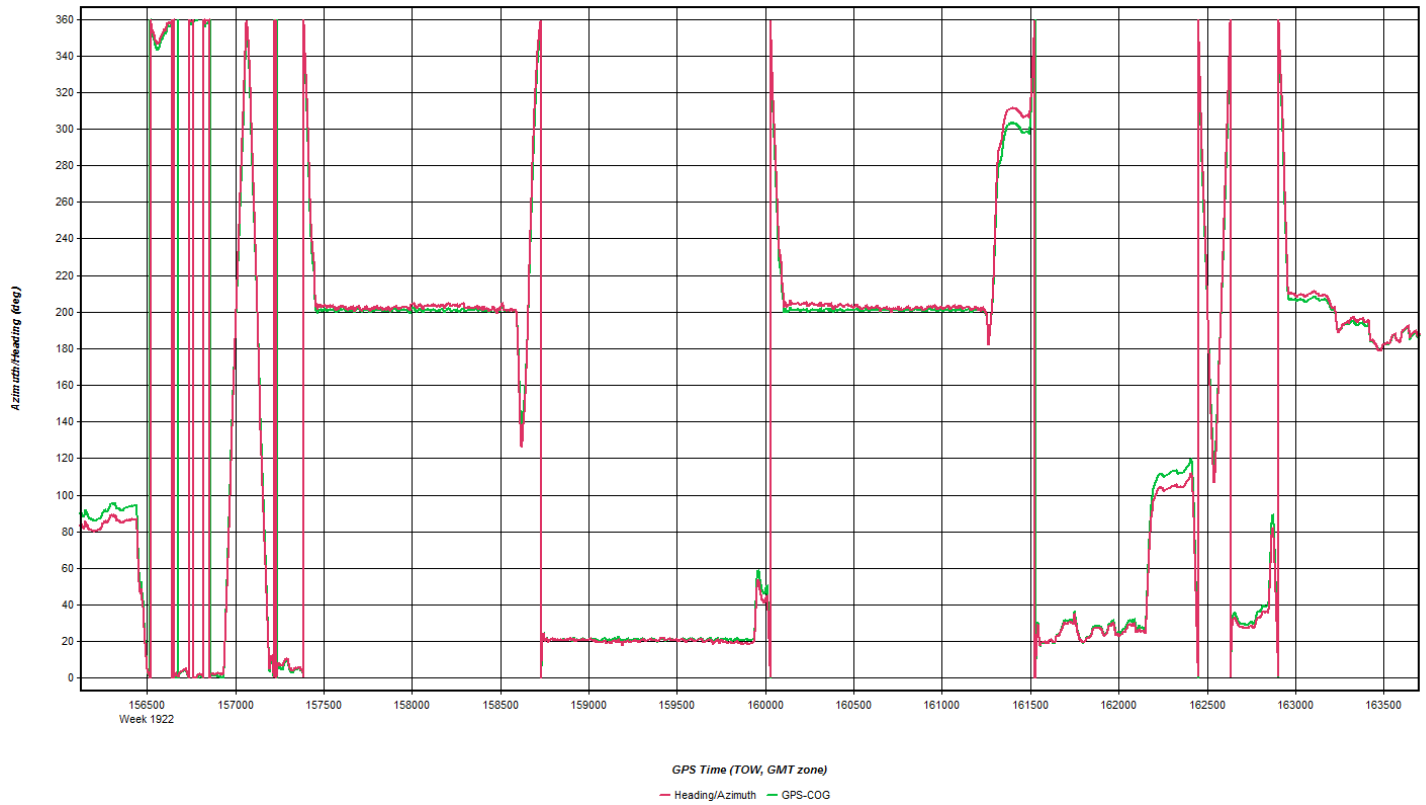
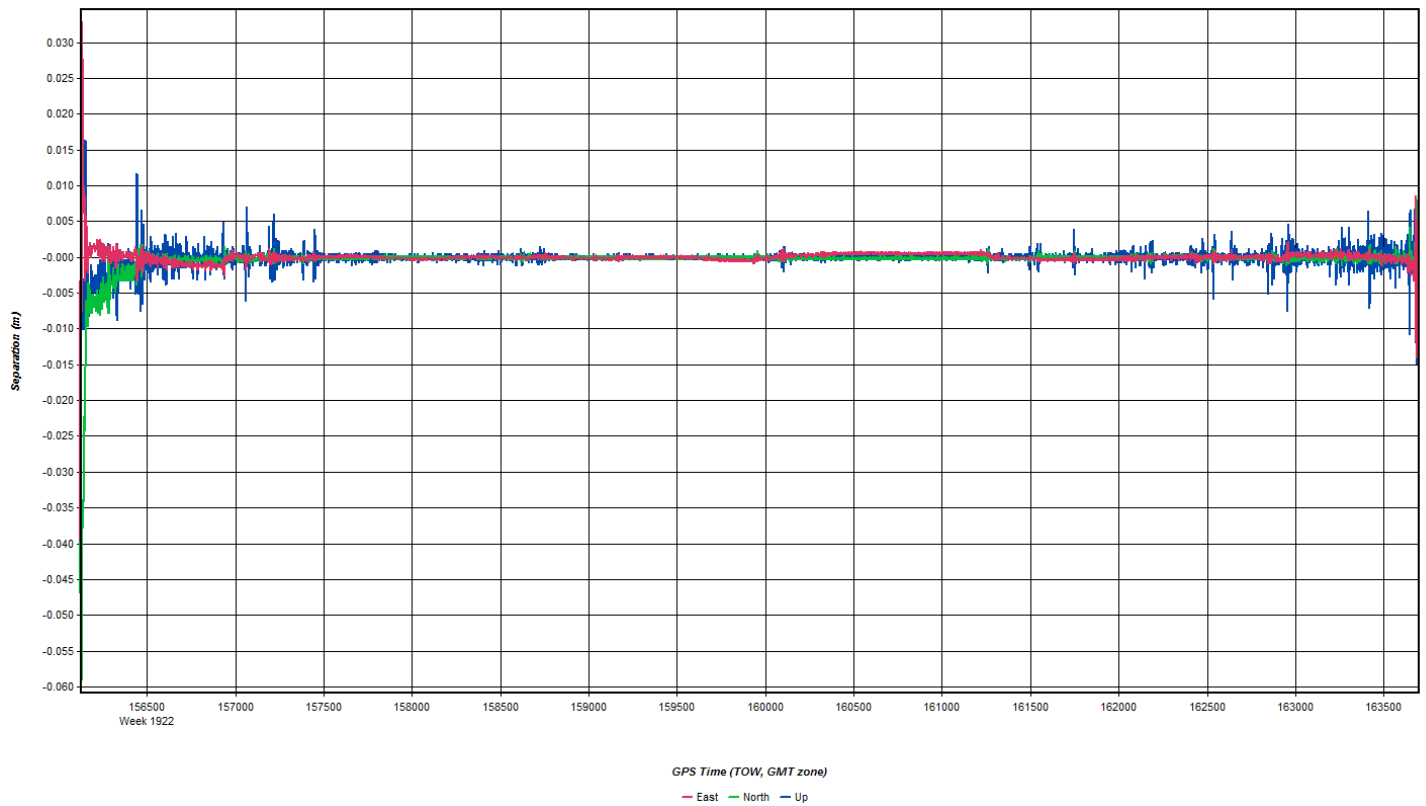

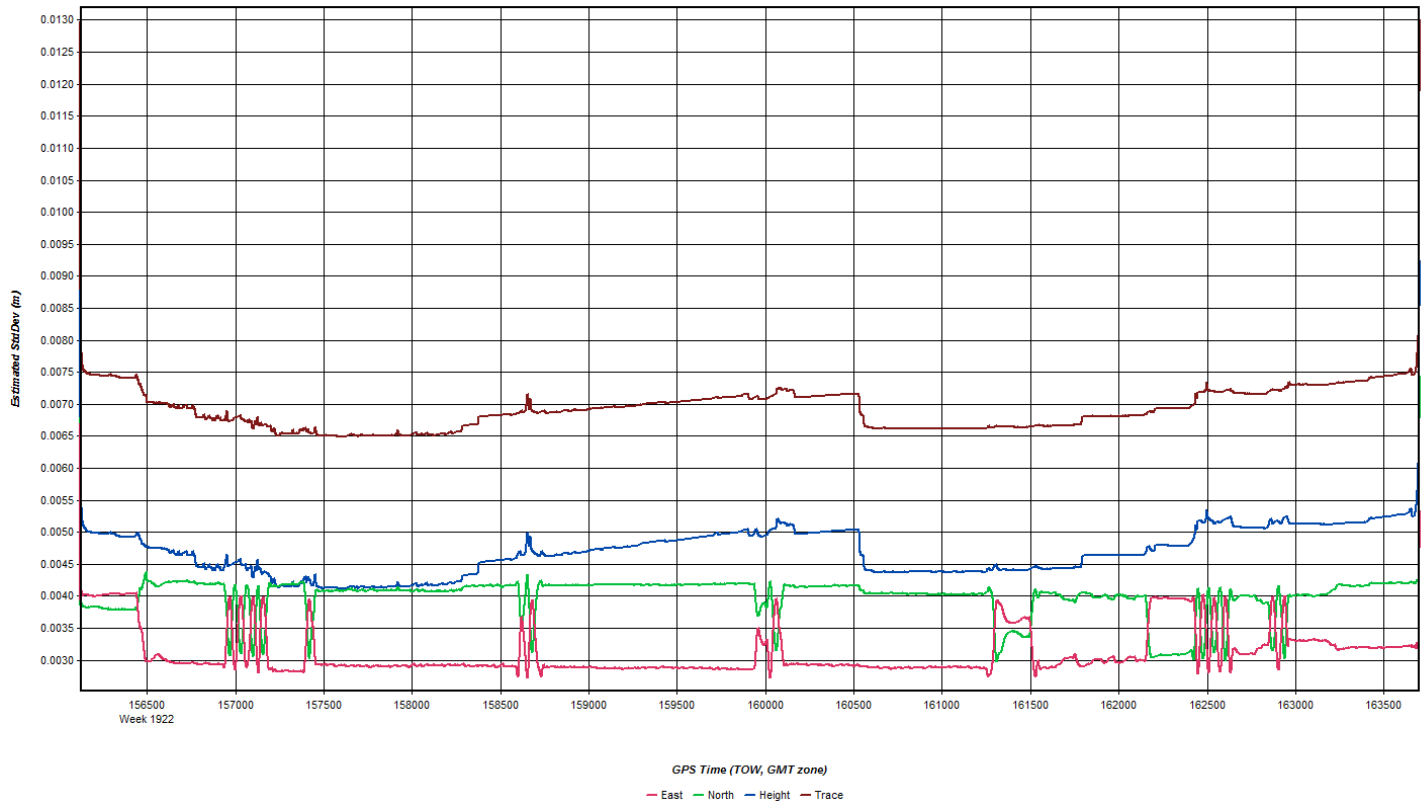
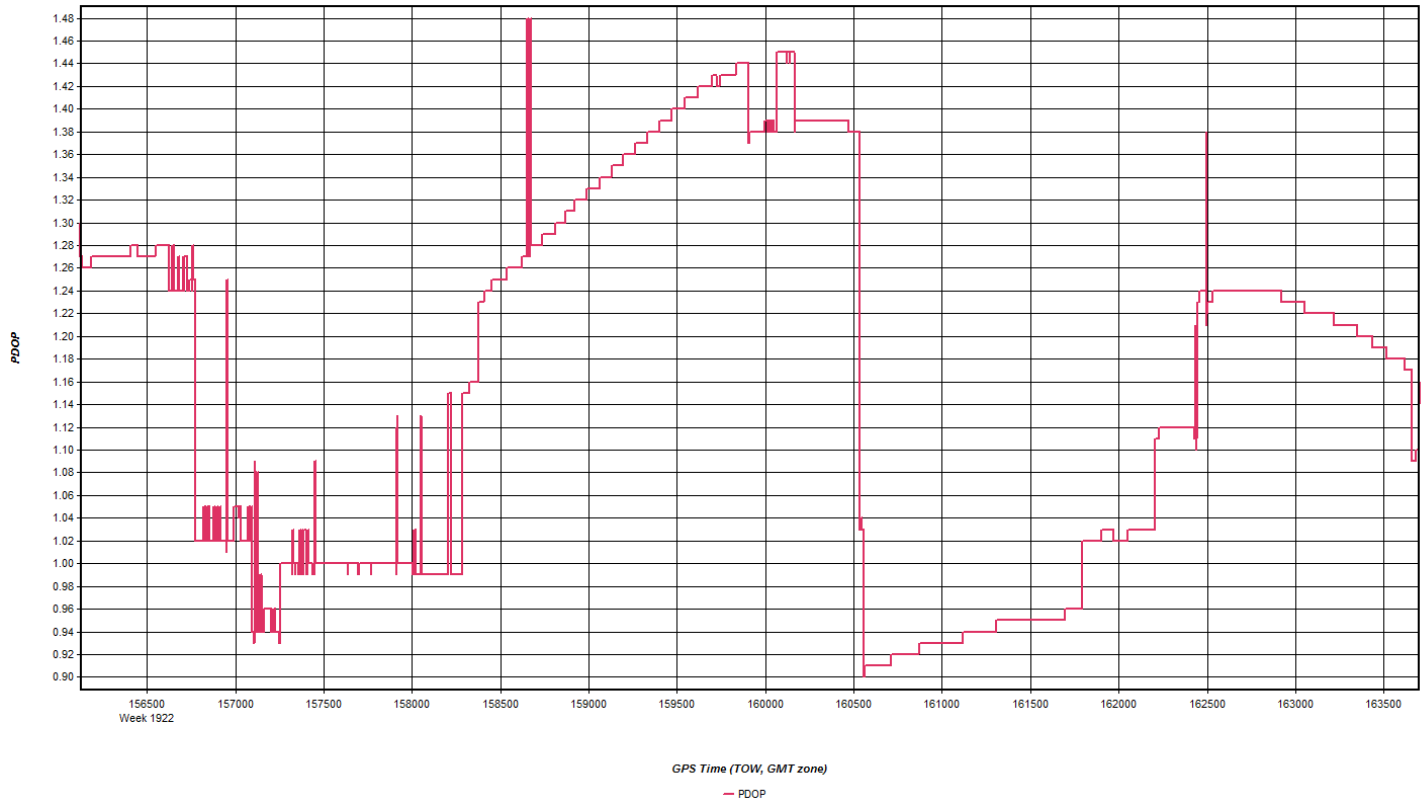

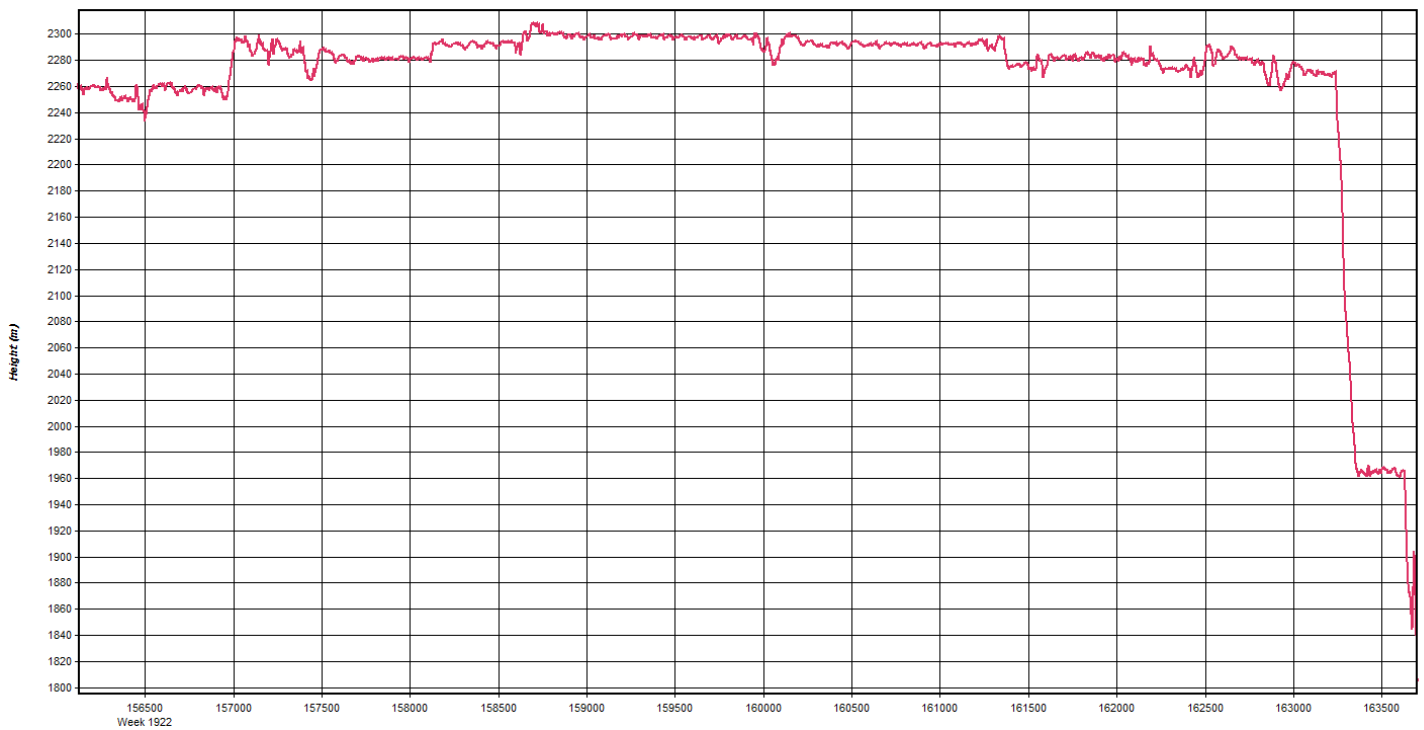
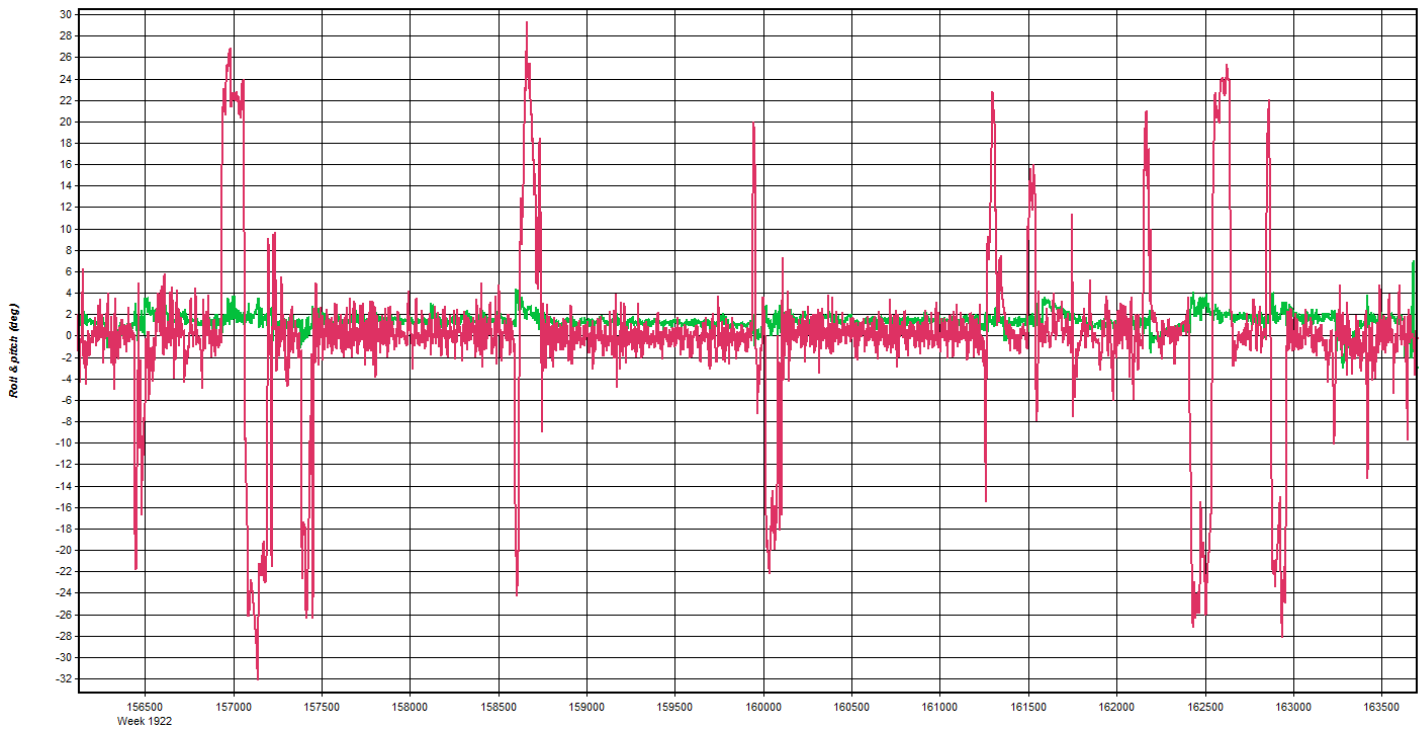

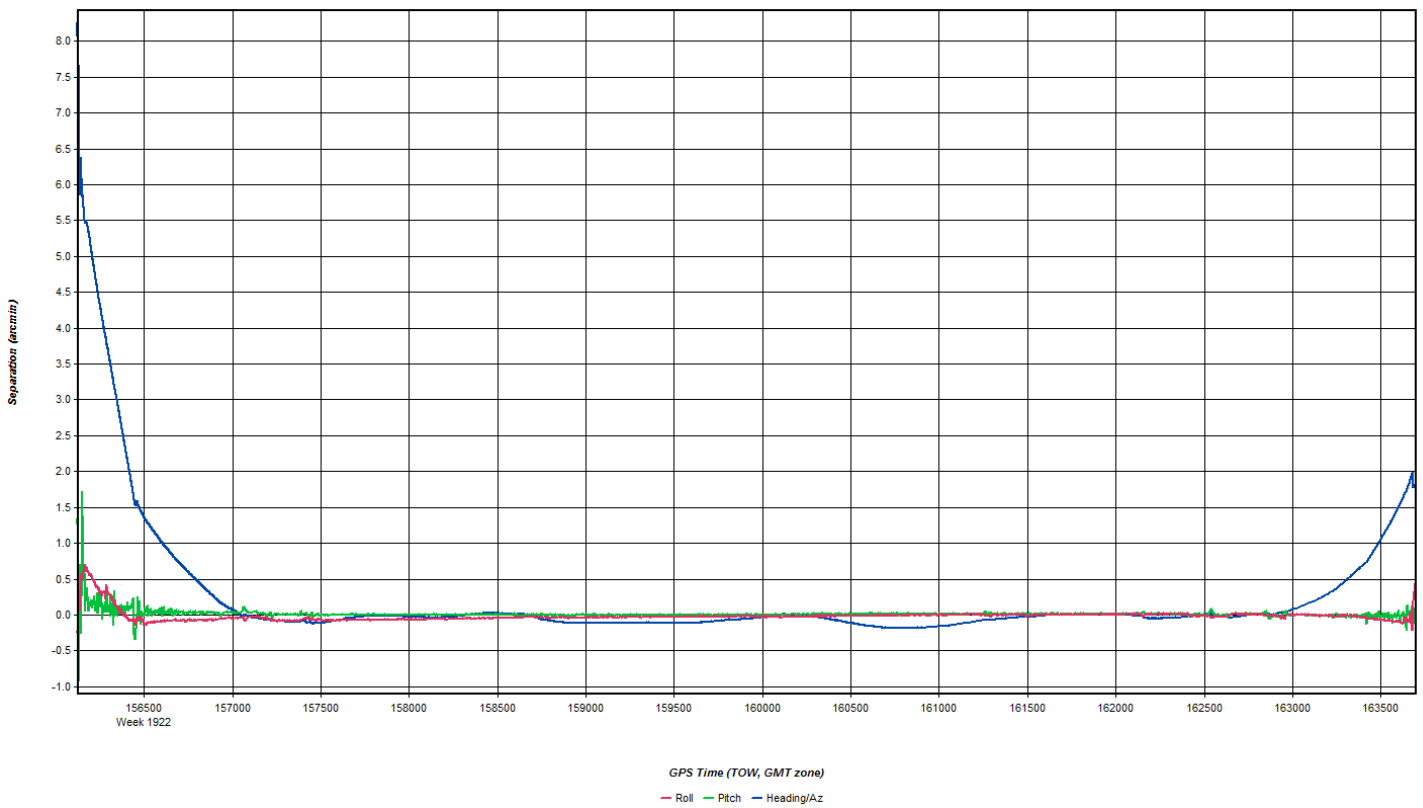
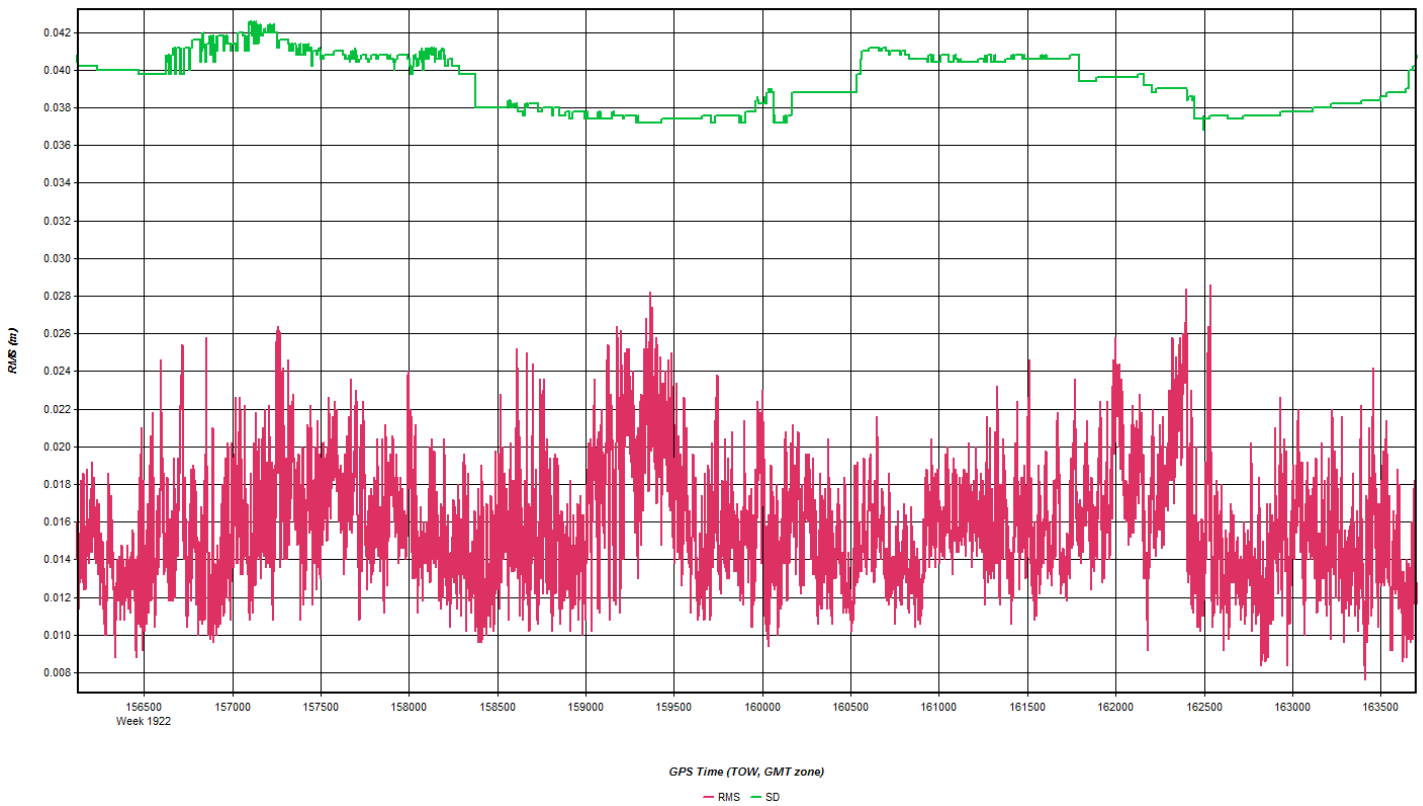

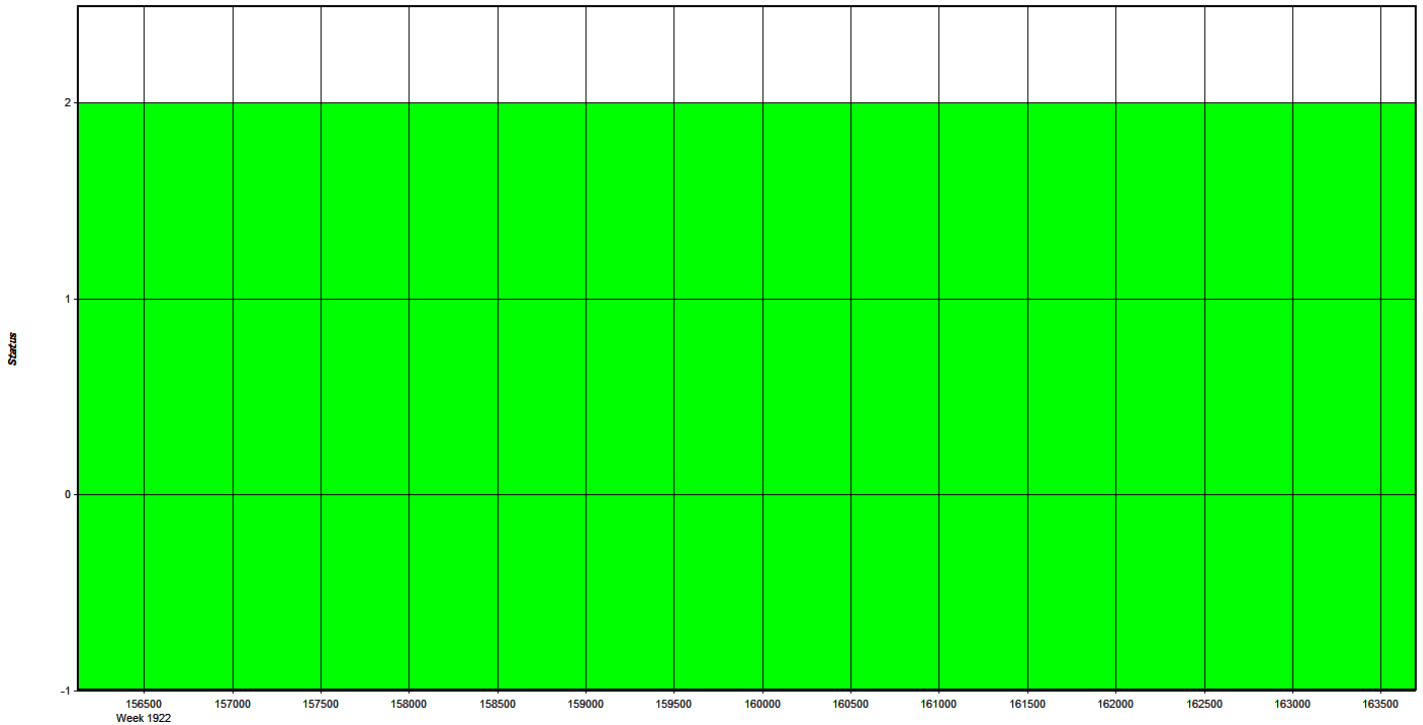

GPS Time (TOW, GMT zone)
 - Float - Forward Fixed - Reverse Fixed - Fixed (2 or more)

Coordinate/Antenna Settings

Master Remote

Base Station
 1: VTD7 Name: VTD7 Disabled
 File: E:\Proc\29178_VT_CT_River_Basin\20161107_A_B_29178_SN7

Coordinates
 Latitude: North 44 23 52.31066 Compute from PPP
 Longitude: West 72 01 32.39267 Enter Grid Values
 Ellipsoidal height: 166.528 m Enter MSL Height
 Datum: WGS84 Datum Options
 Select From Favorites Add To Favorites Use Average Position

Antenna Height
 From station file: TRM55971.00, NONE View STA File
 Antenna profile: TRM55971.00 Info
 Measured height: 0.000 m
 ARP to L1 offset: 0.067 m
 Applied height: 0.067 m
 Measured to:
 ARP
 L1 Phase Centre
 Compute From Slant

OK Cancel

Coordinate/Antenna Settings
? X

Master
Remote

Base Station
Name:
 Disabled

File:

Coordinates
Compute from PPP

Latitude:
North

Enter Grid Values

Longitude:
West

Enter Grid Values

Ellipsoidal height:

Enter MSL Height

Datum:
WGS84
Datum Options

Select From Favorites
Add To Favorites
Use Average Position

Antenna Height
View STA File

From station file:

Antenna profile:
TRM55971.00
Info

Measured height:

ARP to L1 offset:

Applied height:

Measured to

- ARP
- L1 Phase Centre

Compute From Slant

OK
Cancel

Coordinate/Antenna Settings
? X

Master
Remote

Base Station
Name:
 Disabled

File:

Coordinates
Compute from PPP

Latitude:
North

Enter Grid Values

Longitude:
West

Enter Grid Values

Ellipsoidal height:

Enter MSL Height

Datum:
WGS84
Datum Options

Select From Favorites
Add To Favorites
Use Average Position

Antenna Height
View STA File

From station file:

Antenna profile:
TRM55971.00
Info

Measured height:

ARP to L1 offset:

Applied height:

Measured to

- ARP
- L1 Phase Centre

Compute From Slant

OK
Cancel

Flight Log

Airborne LIDAR Data Collection Log Sheet :: Quantum Spatial, Inc

Block 3

Project: **LIDAR - CT River Basin** Proj #: **2978** Flight Mgmt File: **2978-USGS-CTRiverBasin-SN761-15 Sicts**

Altcraft: **N22GE** Begin Hobbs: **8945.1** End Hobbs: **8947.6** Total: **2.5** Pilot: **Carl Christian** Co-Pilot: **Gray, Lois**

Dep Apt: **KBTV** Dep Time (Local): **2:06 ZT** Arr Apt: **KLEB** Arr Time (Local): **4:34 ZT** 21-34 Tot Time Aloft: **2:28**

COORDS: **(Y/N)** Sta 1: **VTD7** Sta 2: _____
Flyovers: **Y/N** IF Y, times: **Sta 1) 19:25 Z Sep 2)**

GPS Unit: **Y/N** Sta 1: _____ Sta 2: _____
Flyovers: **Y/N** IF Y, times: **Sta 1) 21:18 Z Sta 2)**

Line #	Hdg	Start (UTC)	End (UTC)	Gd Spd	Gd Altitude	Crab	Type (0-3)	Altimeter height:			Avg Pwr	Fuel Use	Temp
								AGL	MSL	Pressure			
								7161	2000	7400	5400	155 kts	
								5747	MPLA (Y/N)			100%	2
								11/18					
								19:27	165	7400'			
								19:36					
								19:45	158	7500'			
								20:03	158	7500'			
								20:25	141	7500'			
								20:29	152	7900'			
								21:03					
								21:07					
								21:16	170	7500'			

FLIGHT LINE NOTES - visibility, clouds, smoke, period, etc.

307 Flyover VTD7

3016 Partial Fig 8

3015 Clear

UL001 Clear

UL001 CROSS TIE UL001

21:16 Closeout Fig 8

21:16 close-out flyover of VTD7

Total Proj Lines: _____ Lines Flown: 3 Lines Remains: NA Online Time: _____ Mob Time: 24 Notes: _____

Nov 7, 2016-B (N73TM, SN7178)

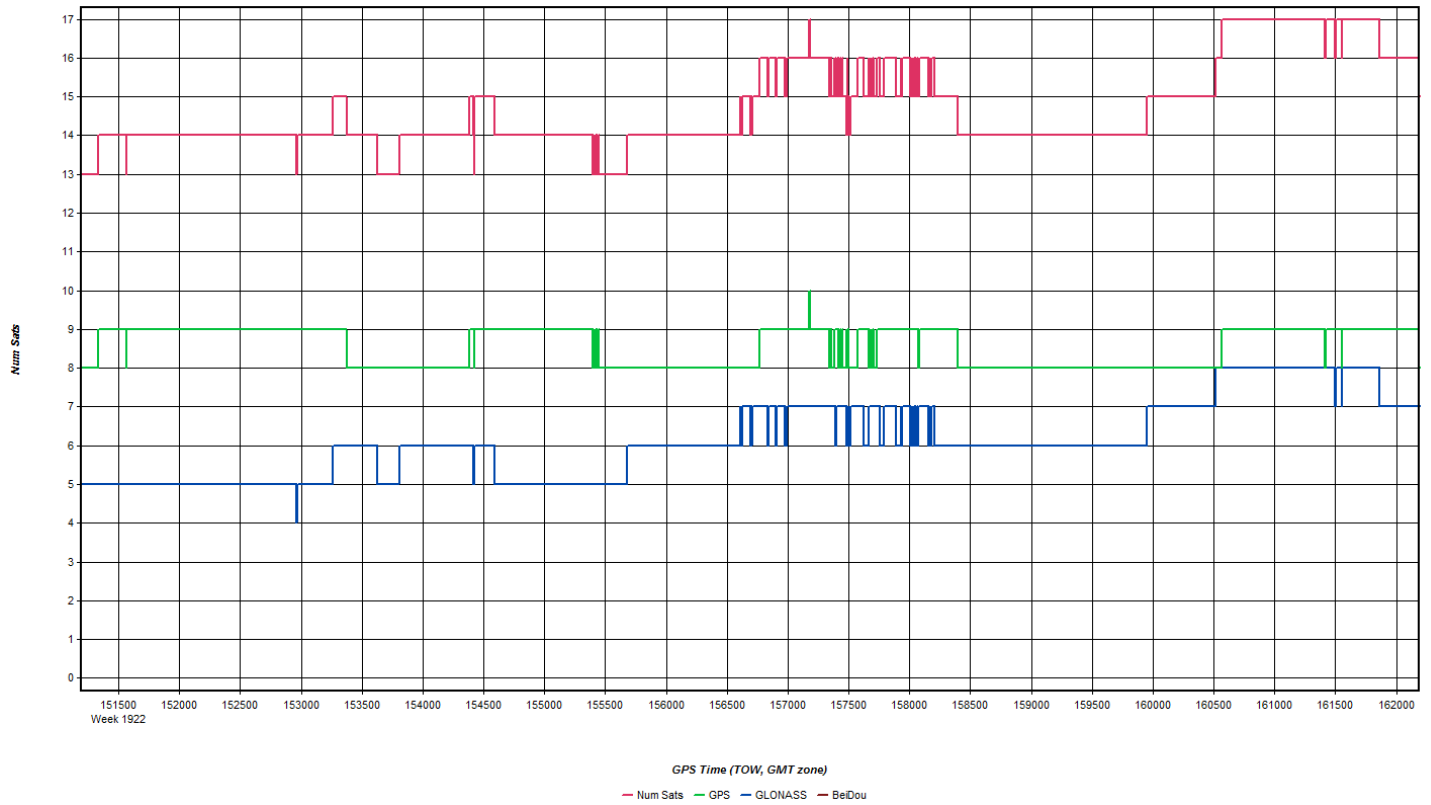
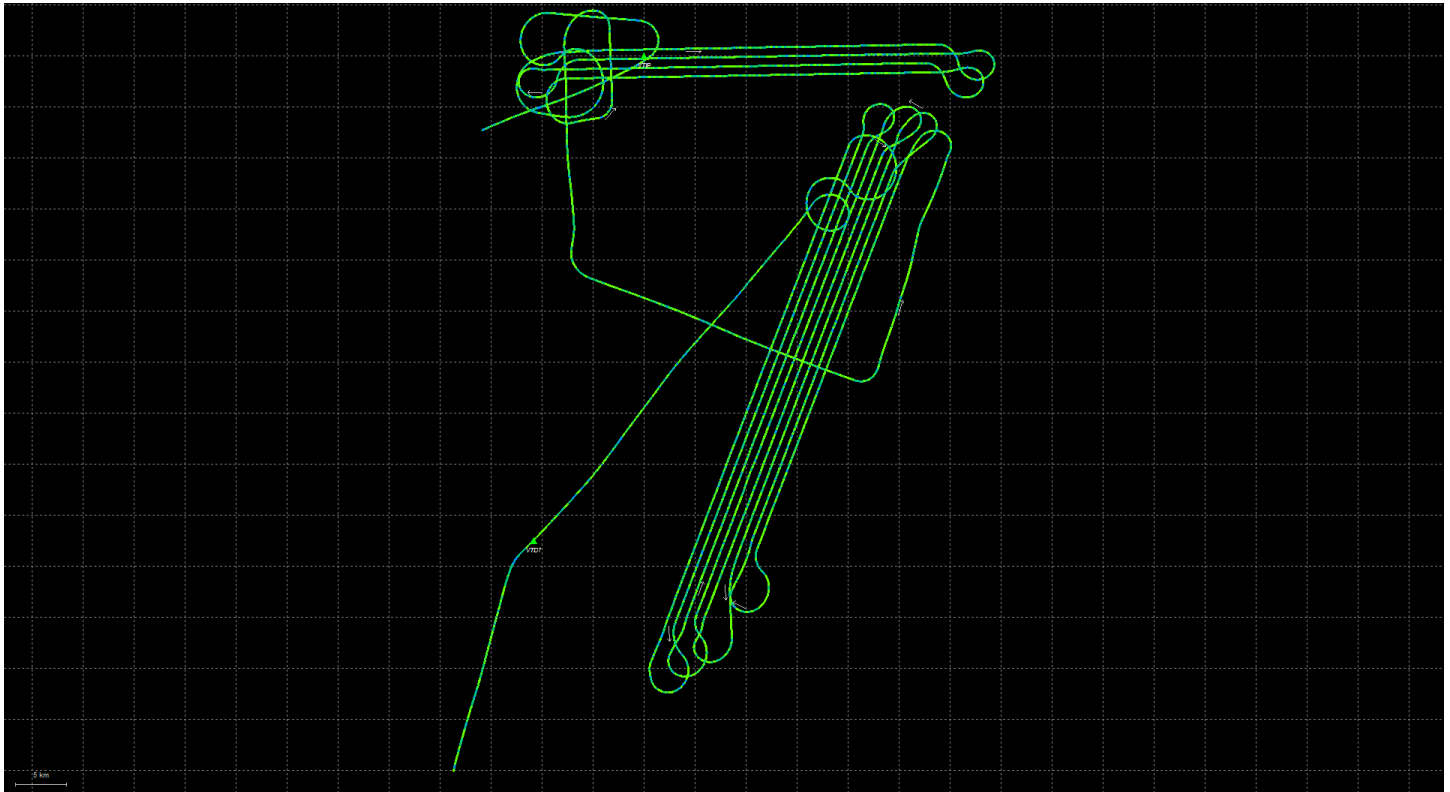

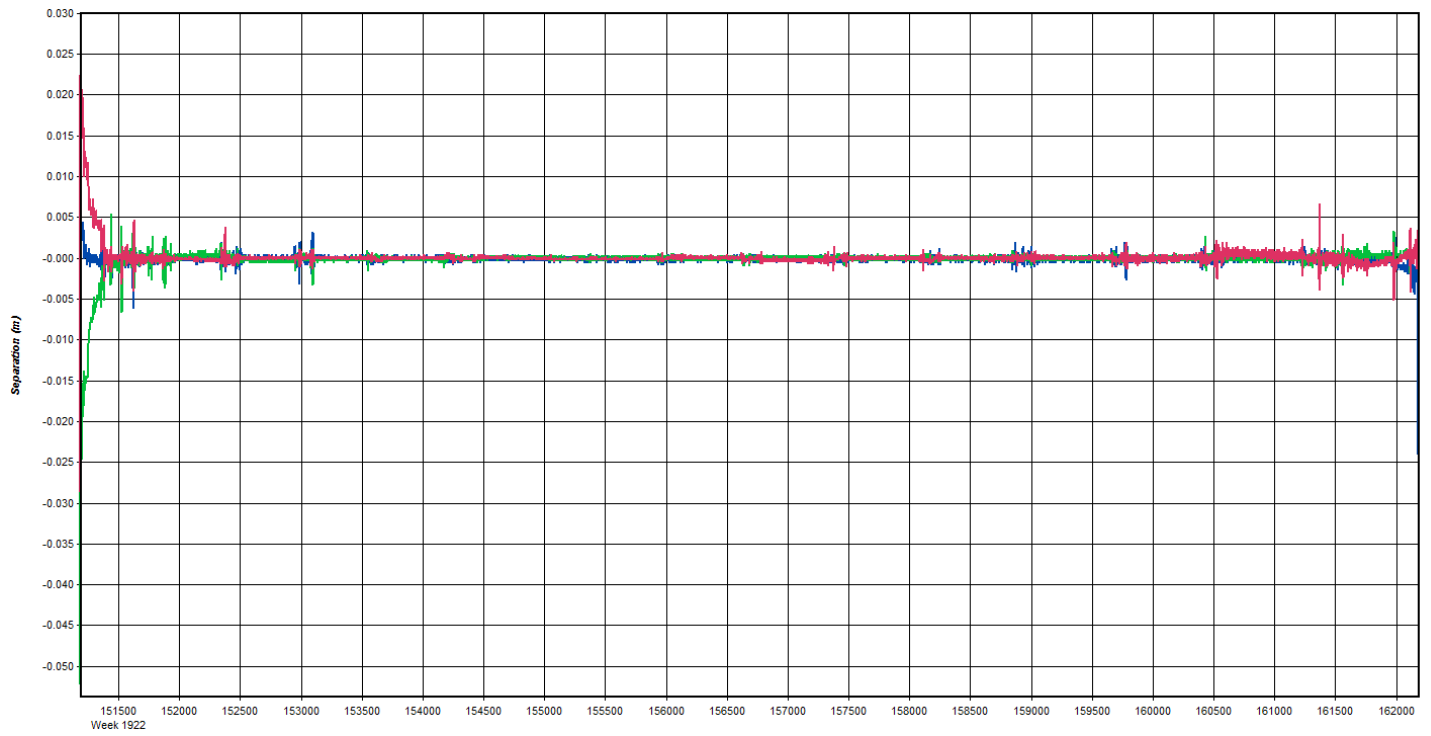

GPS Time (TOW, GMT zone)
— East — North — Up

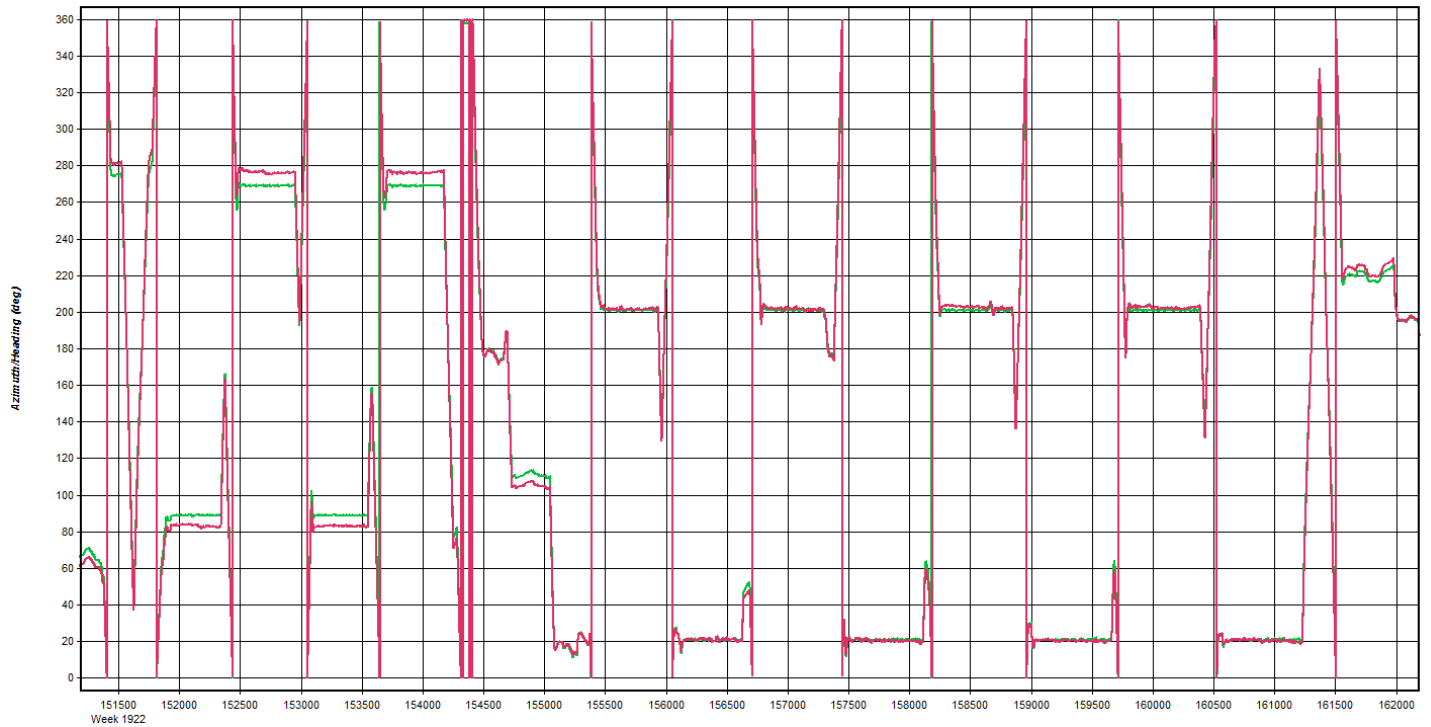

GPS Time (TOW, GMT zone)
— Heading/Azimuth — GPS-COG

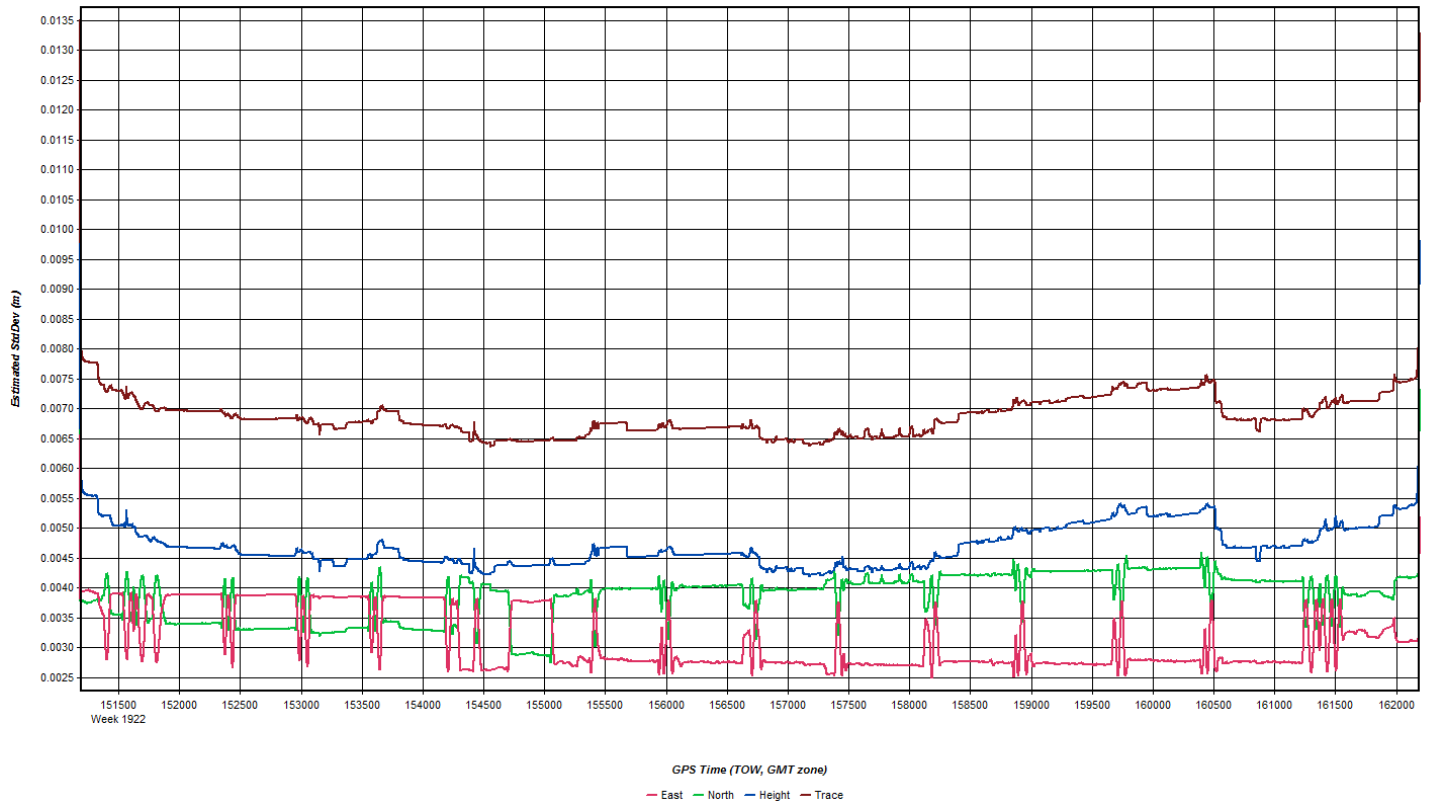
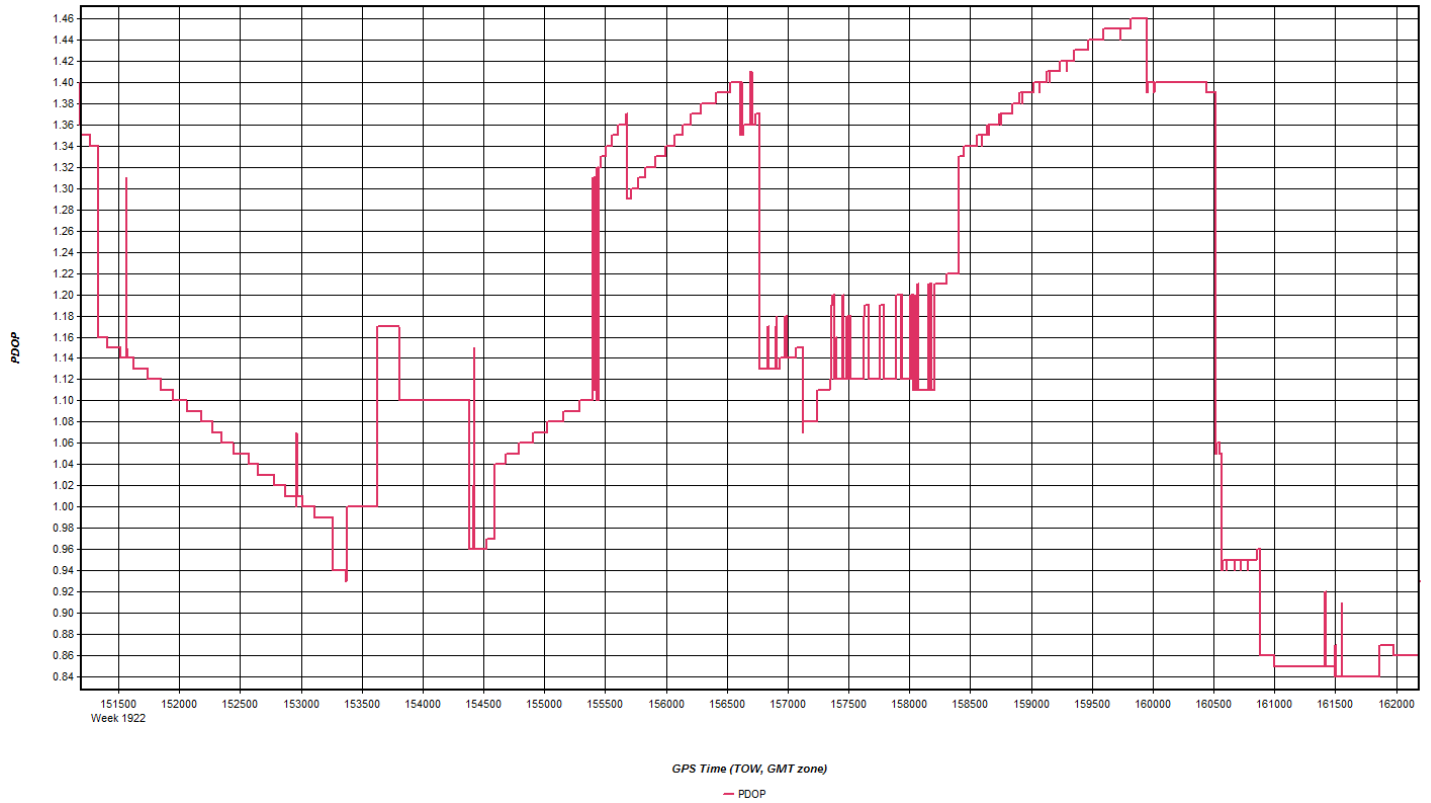

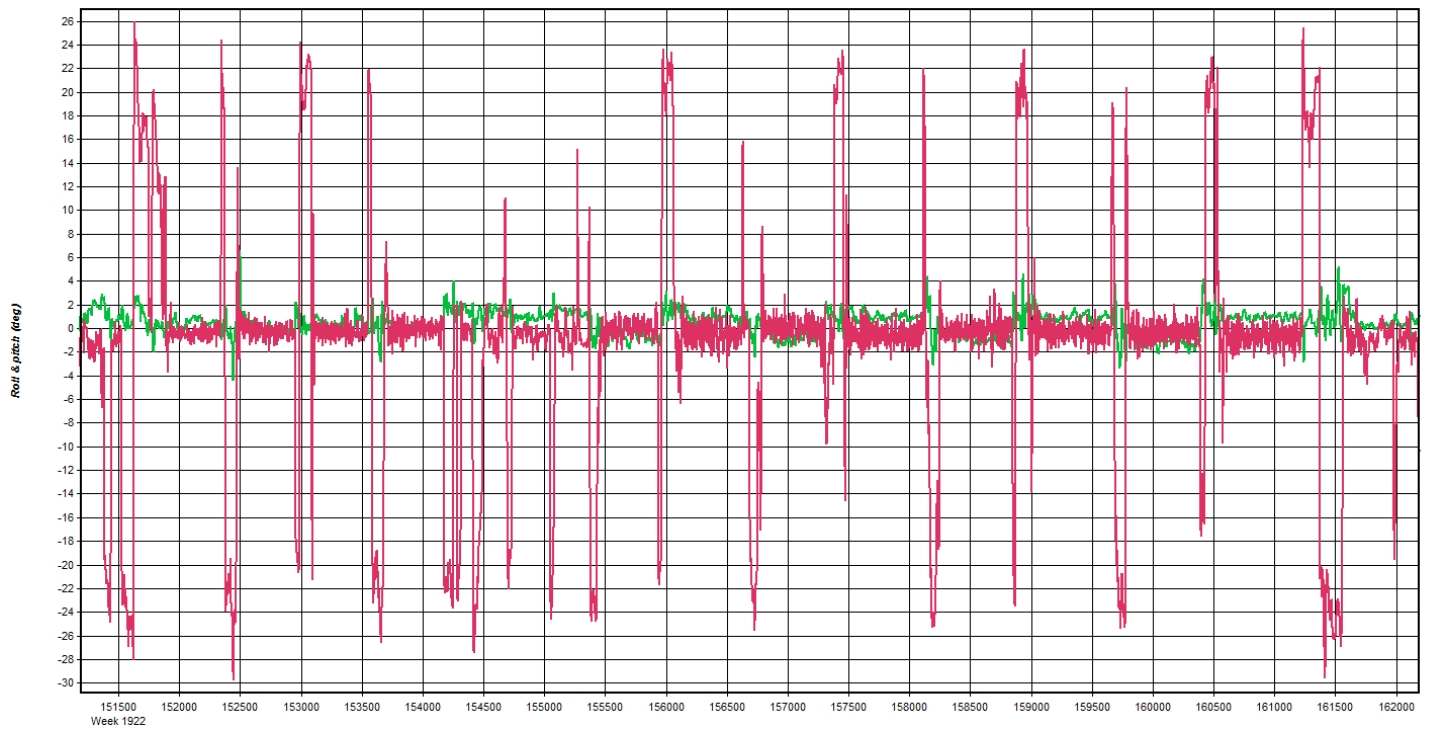

GPS Time (TOW, GMT zone)

— Roll — Pitch

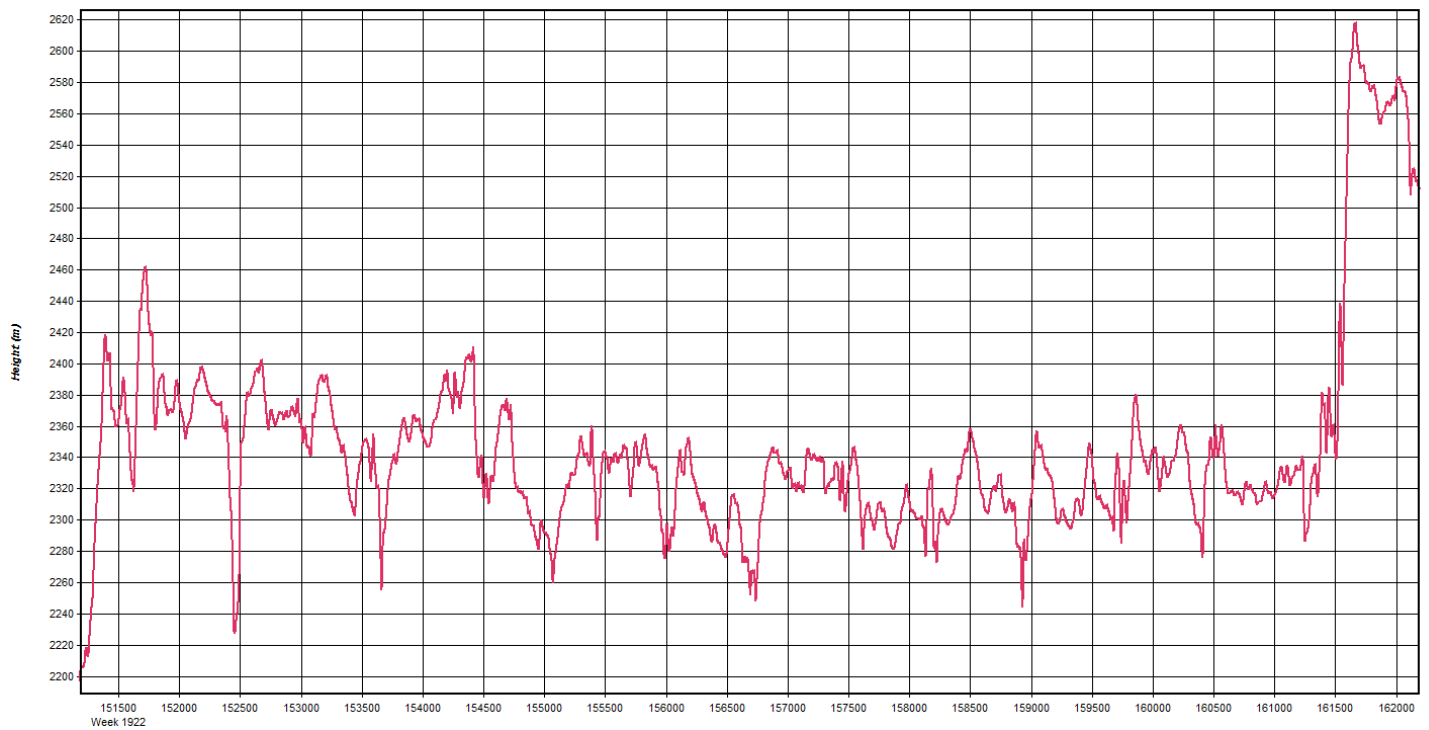

GPS Time (TOW, GMT zone)

— Height

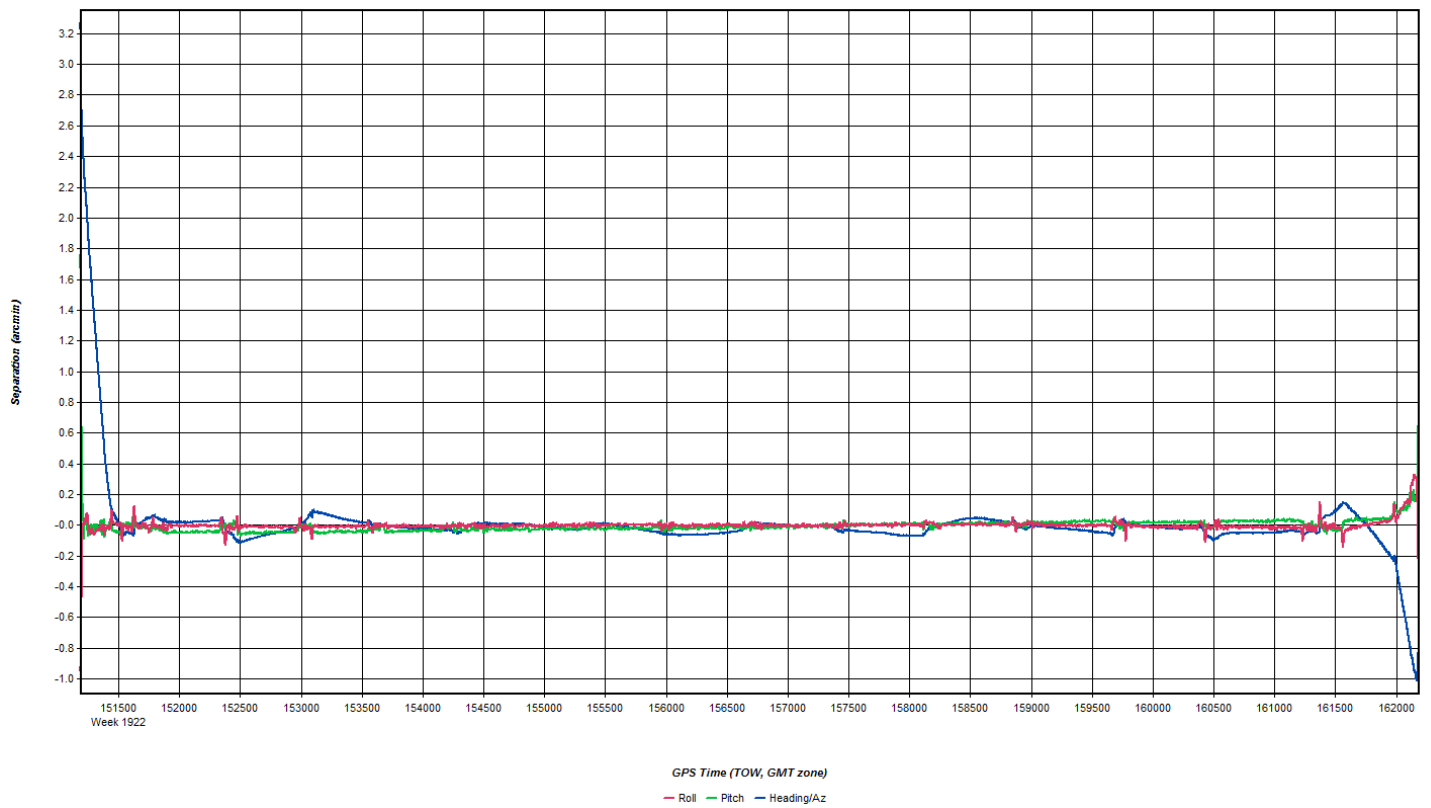
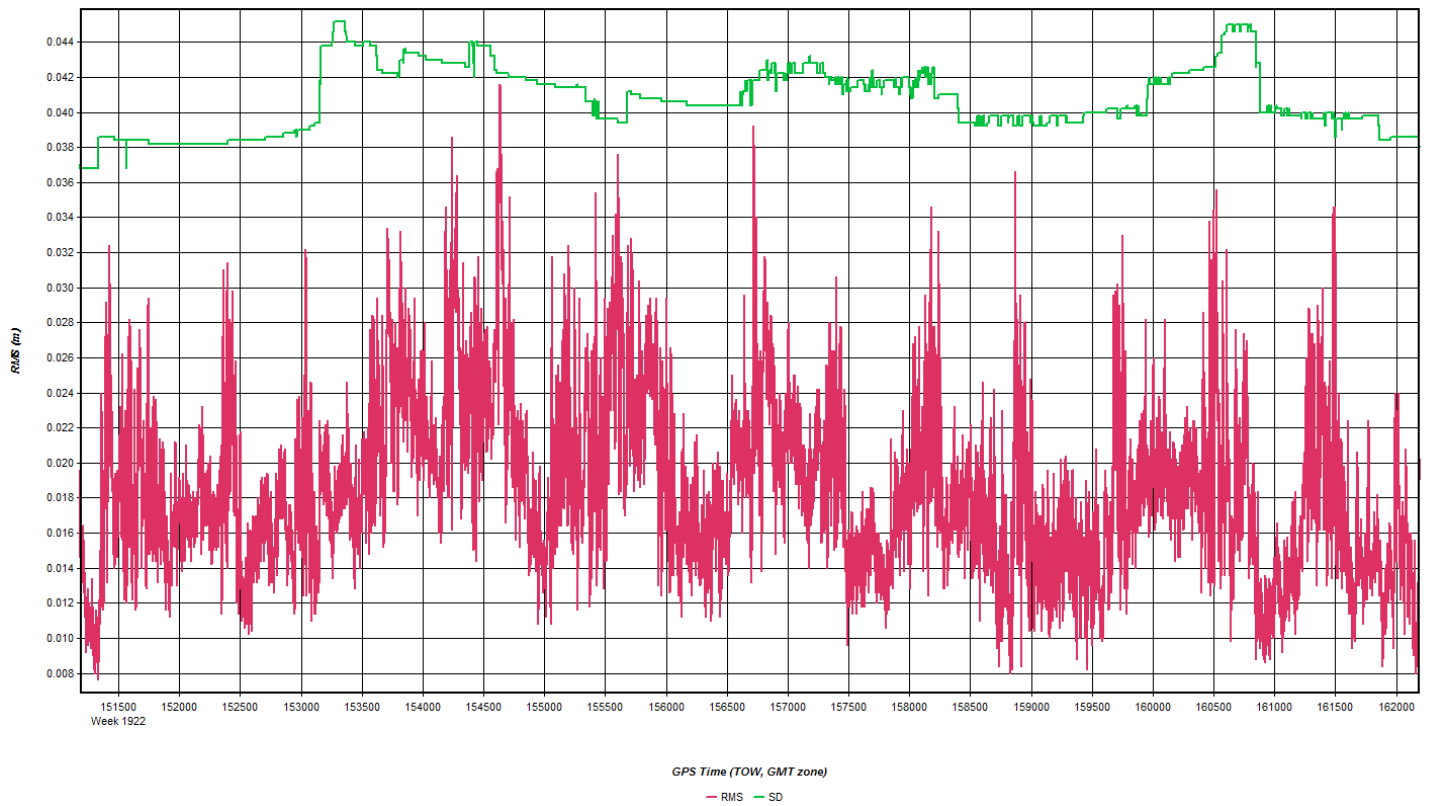

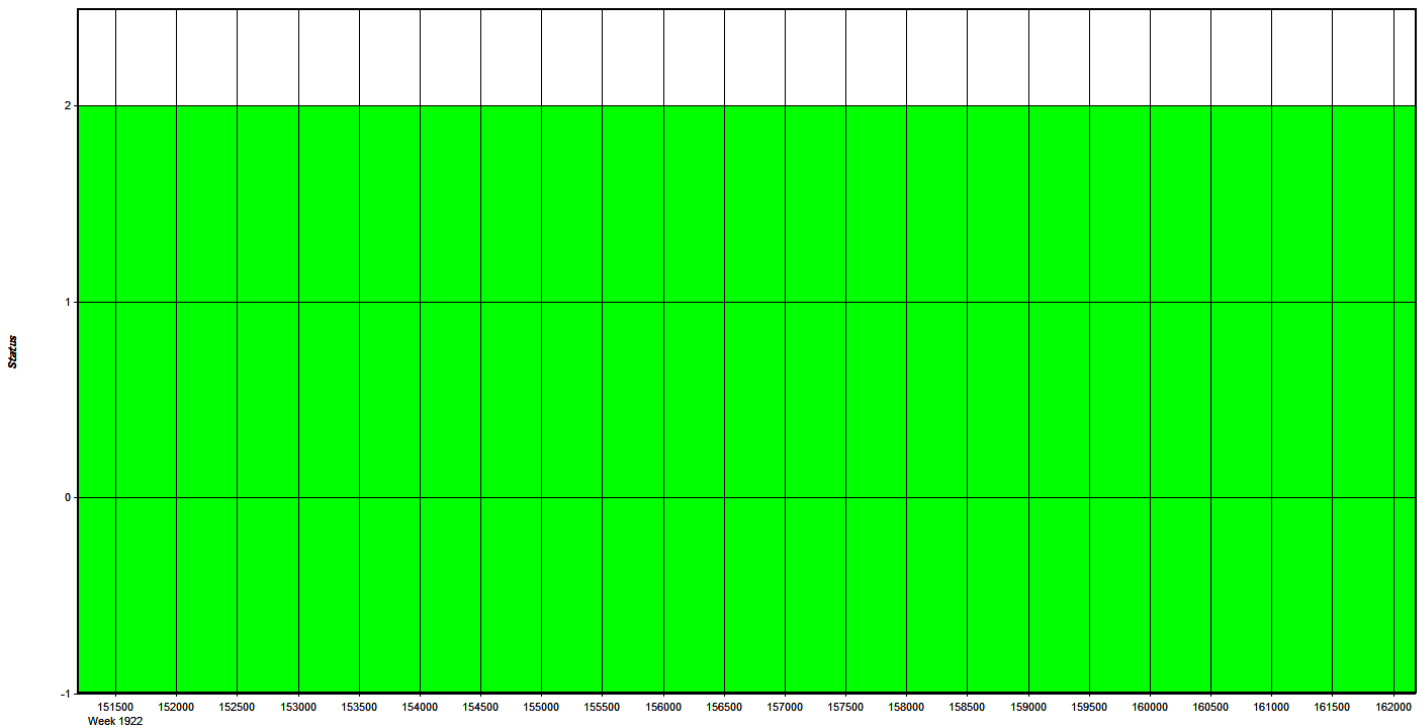

GPS Time (TOW, GMT zone)
 - Float - Forward Fixed - Reverse Fixed - Fixed (2 or more)

Coordinate/Antenna Settings

Master Remote

Base Station
 2: VTD7 Name: VTD7 Disabled
 File: E:\Proc\29178_VT_CT_River_Basin\20161107_AB_29178_ALS7

Coordinates
 Latitude: North 44 23 52.31066 Compute from PPP
 Longitude: West 72 01 32.39267 Enter Grid Values
 Ellipsoidal height: 166.528 m Enter MSL Height
 Datum: WGS84 Datum Options
 Select From Favorites Add To Favorites Use Average Position

Antenna Height
 From station file: TRM55971.00, NONE View STA File
 Antenna profile: TRM55971.00 Info
 Measured height: 0.000 m
 ARP to L1 offset: 0.067 m
 Applied height: 0.067 m
 Measured to:
 ARP
 L1 Phase Centre
 Compute From Slant

OK Cancel

Coordinate/Antenna Settings

Master Remote

Base Station
 1: VTIP Name: VTIP Disabled
 File: E:\Proc\29178_VT_CT_River_Basin\20161107_AB_29178_ALS7

Coordinates
 Latitude: North 44 49 12.18043 Compute from PPP
 Longitude: West 71 53 25.83872 Enter Grid Values
 Ellipsoidal height: 341.732 m Enter MSL Height
 Datum: WGS84 Datum Options
 Select From Favorites Add To Favorites Use Average Position

Antenna Height
 From station file: TRM55971.00, NONE View STA File
 Antenna profile: TRM55971.00 Info
 Measured height: 0.000 m
 ARP to L1 offset: 0.067 m
 Applied height: 0.067 m
 Measured to:
 ARP
 L1 Phase Centre
 Compute From Slant

OK Cancel

Flight Log

Scanned by CamScanner

Date: 11-7-16
Lit: B C D E Pg 1 of 1

Airborne LiDAR Data Collection Log Sheet :: Quantum Spatial, Inc
(email: log.daily.to.flight_log_distribution_list@quantumspatial.com)

Project: 0505 ST RIVER BASIN Proj #: 29177 Flight Mgmt File: 29178_0505_WINDSOR_CO_VT_1107_172233
Aircraft: N737MA Begin Hobbs: 6466.4 End Hobbs: 6470.0 Total: 3.6 Pilot: BULLINGTON Co-Pilot: - Tech: MURPHY
Dep Apt: BTW Dep Time (Lcl): 1240 (Z): 1740 Arr Apt: ZEB Arr Time (Local): 1615 (Z): 2115 Tot Time Aloft: 3:35
CORR: 0/N Sta 1: VT19, VT07 Sta 2: Flyovers: 0/N If Y, times: Sta 1 1802, 2059 Sta 2)
GPS Unit: Y/N Sta 1: Flyovers: Y/N If Y, times: Sta 1 (VT19) (VT07) Sta 2)

Gd Temp beg: °C End: °C OAT beg: °C End: °C Altimeter begin: °C		Alt: ± 7900' Avg Terr Hit: 1100' Max Gdspd: 155		Avg Pt Spacing: 155		Beg CB: 33		Storage Name: 7178	
Type	Serial #	Alt ± AGL	Alt ± AMSL	Pulse Rate	Power	Pulse Rate	End	End	End
FOV	Scan Freq	MPIA	In Air	Z	KHP	Z	0	0	0
4026	089	1807							
4026	089	1811							
4027	269	1821							
4028	089	1831							
4029	269	1842							
TIME	358	1851							
TIME	110	1858							
3053	201	1911							
3052	021	1921							
3051	201	1933							
3050	021	1944							
3049	201	1957							
3048	021	2010							
3047	201	2024							
3046	021	2036							

FLIGHT LINE NOTES - visibility, clouds, smoke, partial, etc.

- BUSTED LIMBS REFLY

- TIE LINE FOR LINES 4026-4029

- TIE LINE FOR BACK 3

Total Proj Lines: 1 Lines Flown: 1 Lines Remain: 0 Online Time: 2.5 Mob Time: 1.0 Notes:

Nov 8, 2016-A (N22GE, SN7161)

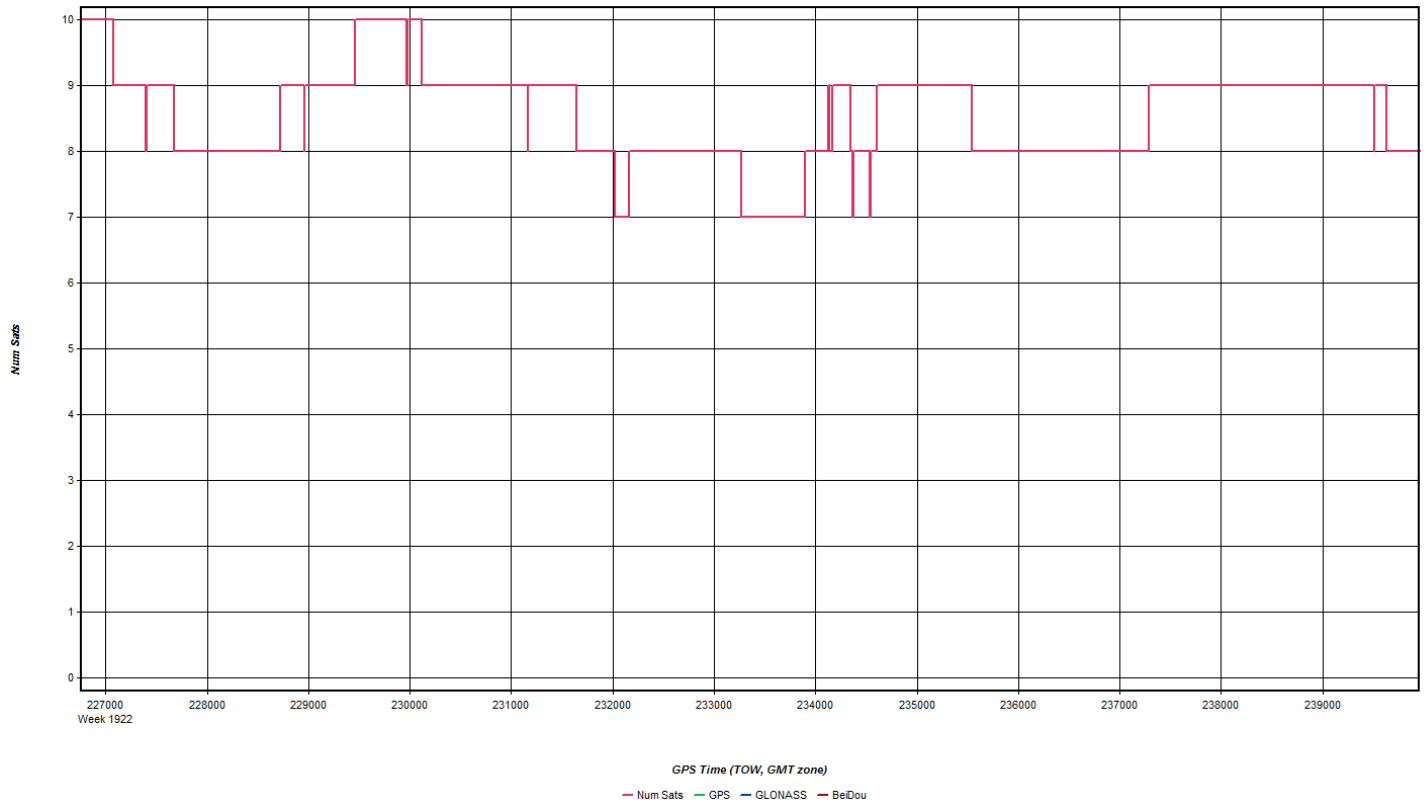
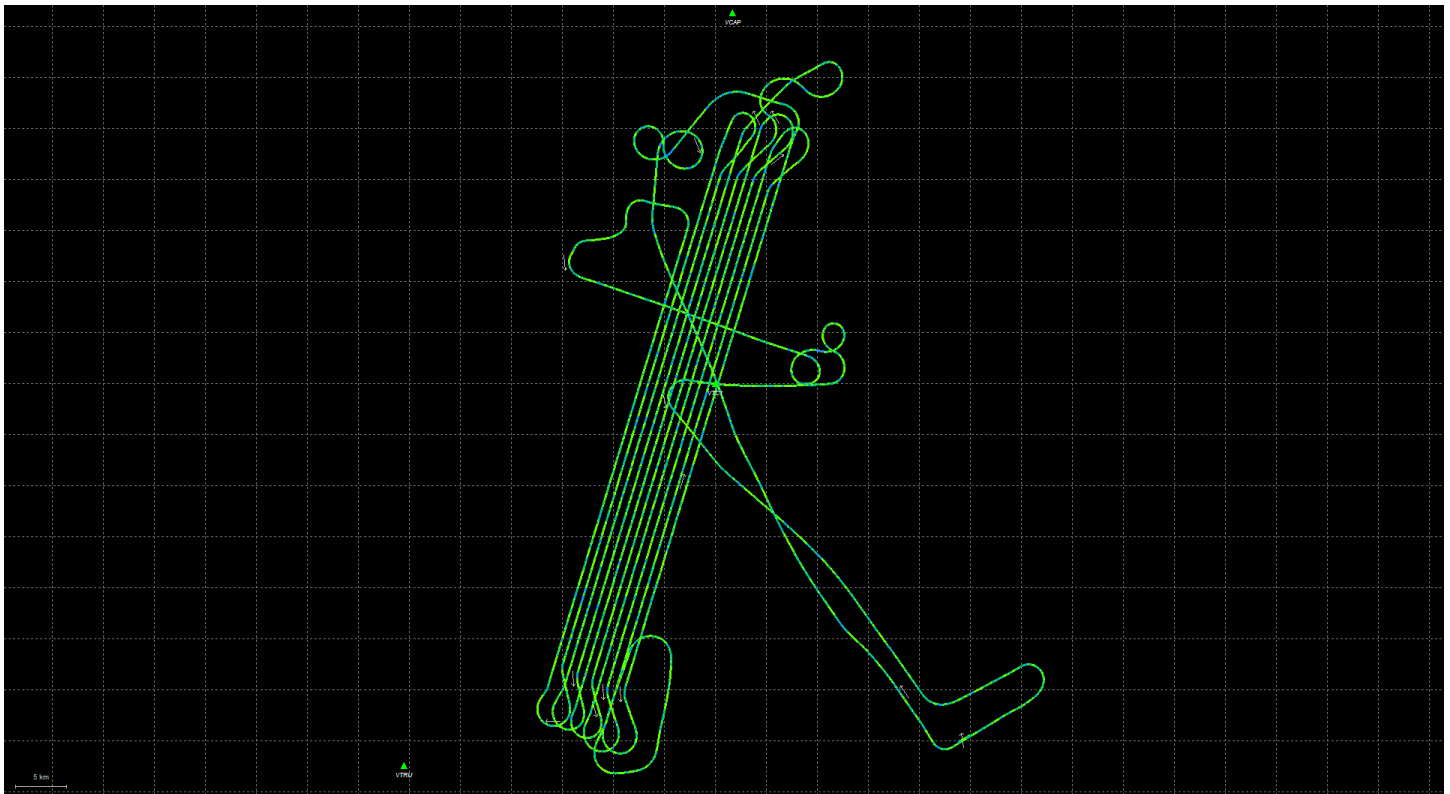

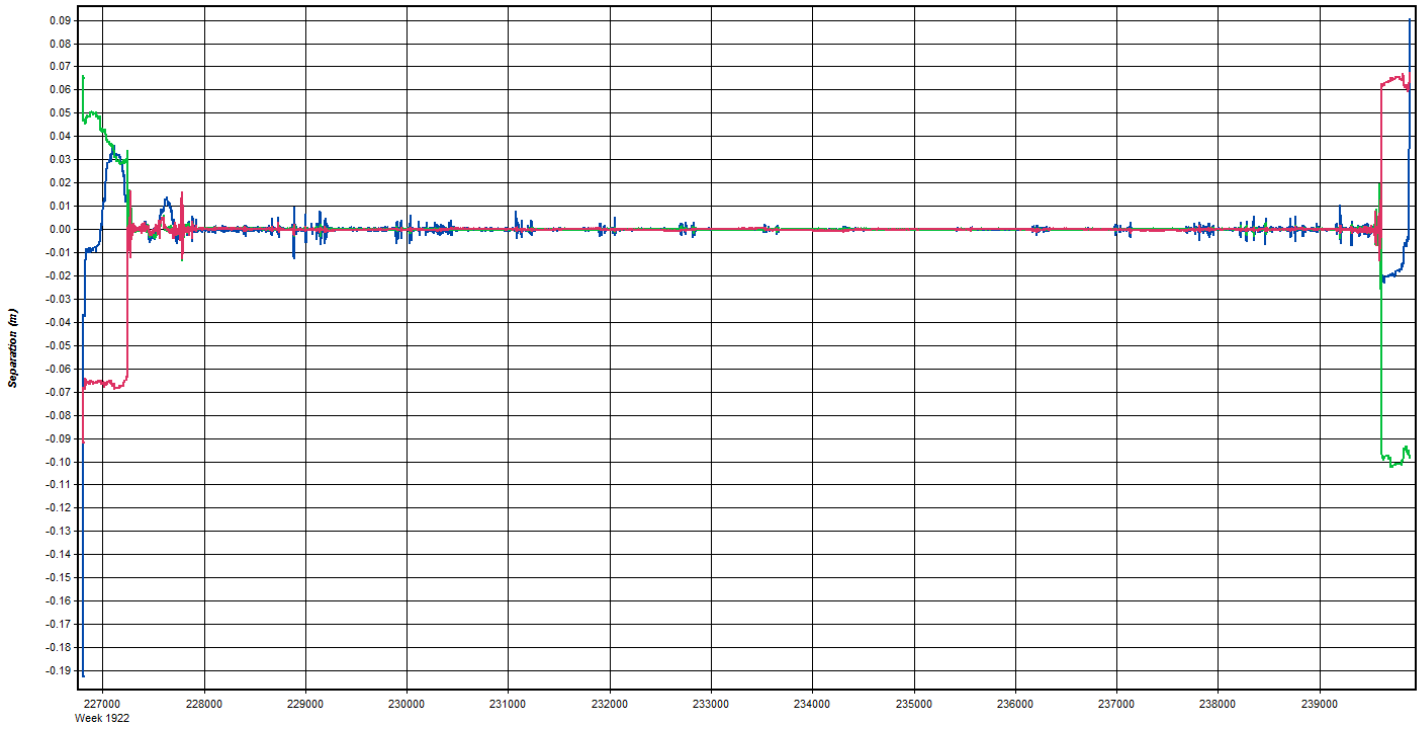

GPS Time (TOW, GMT zone)
— East — North — Up

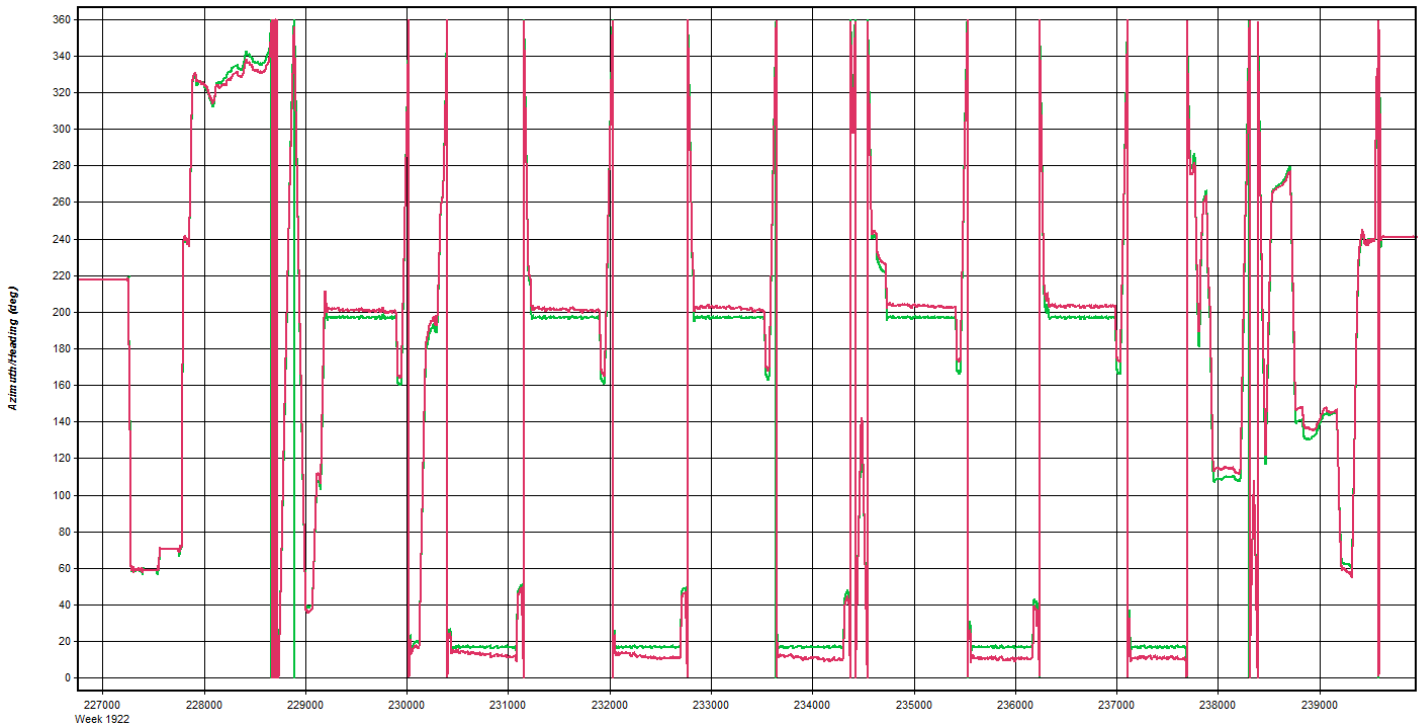

GPS Time (TOW, GMT zone)
— Heading/Azimuth — GPS-COG

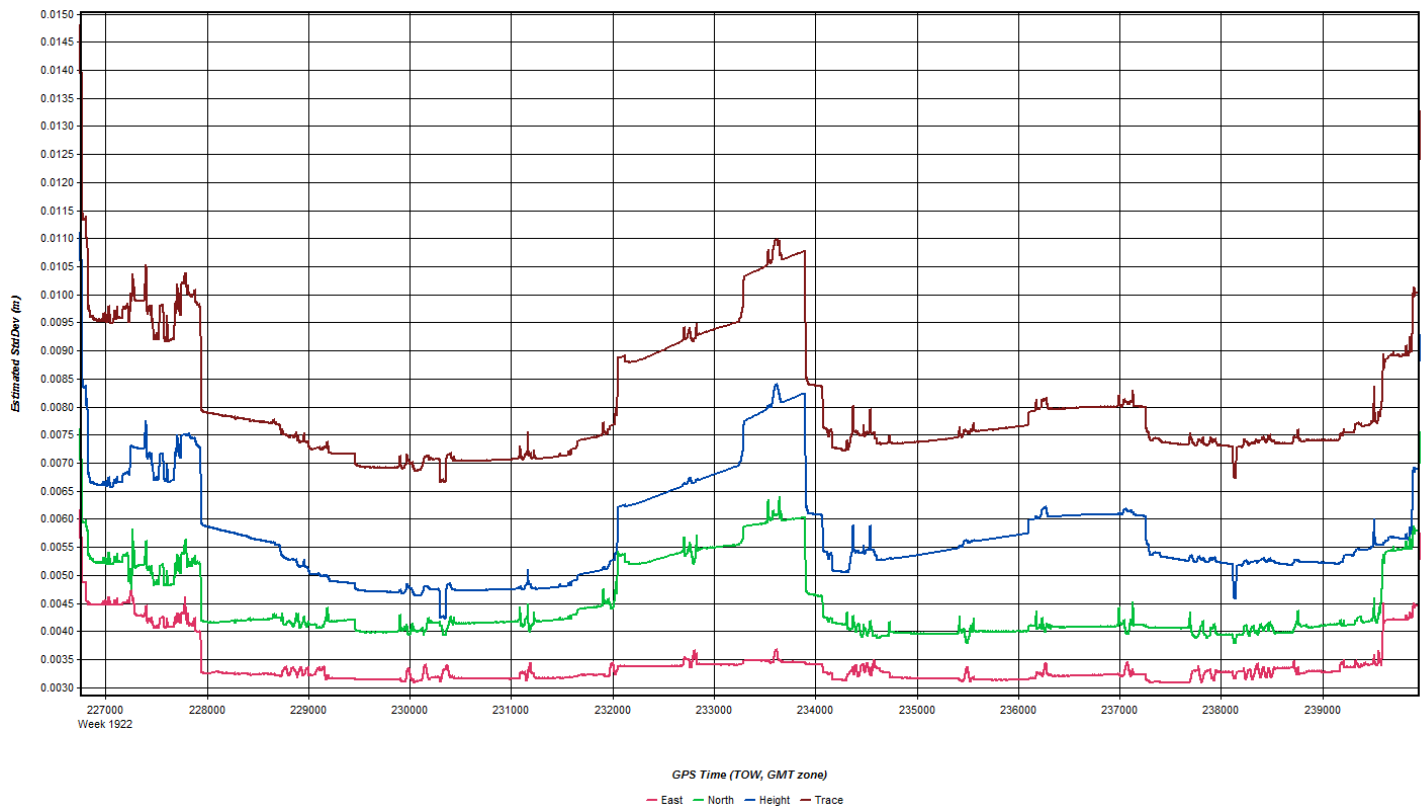
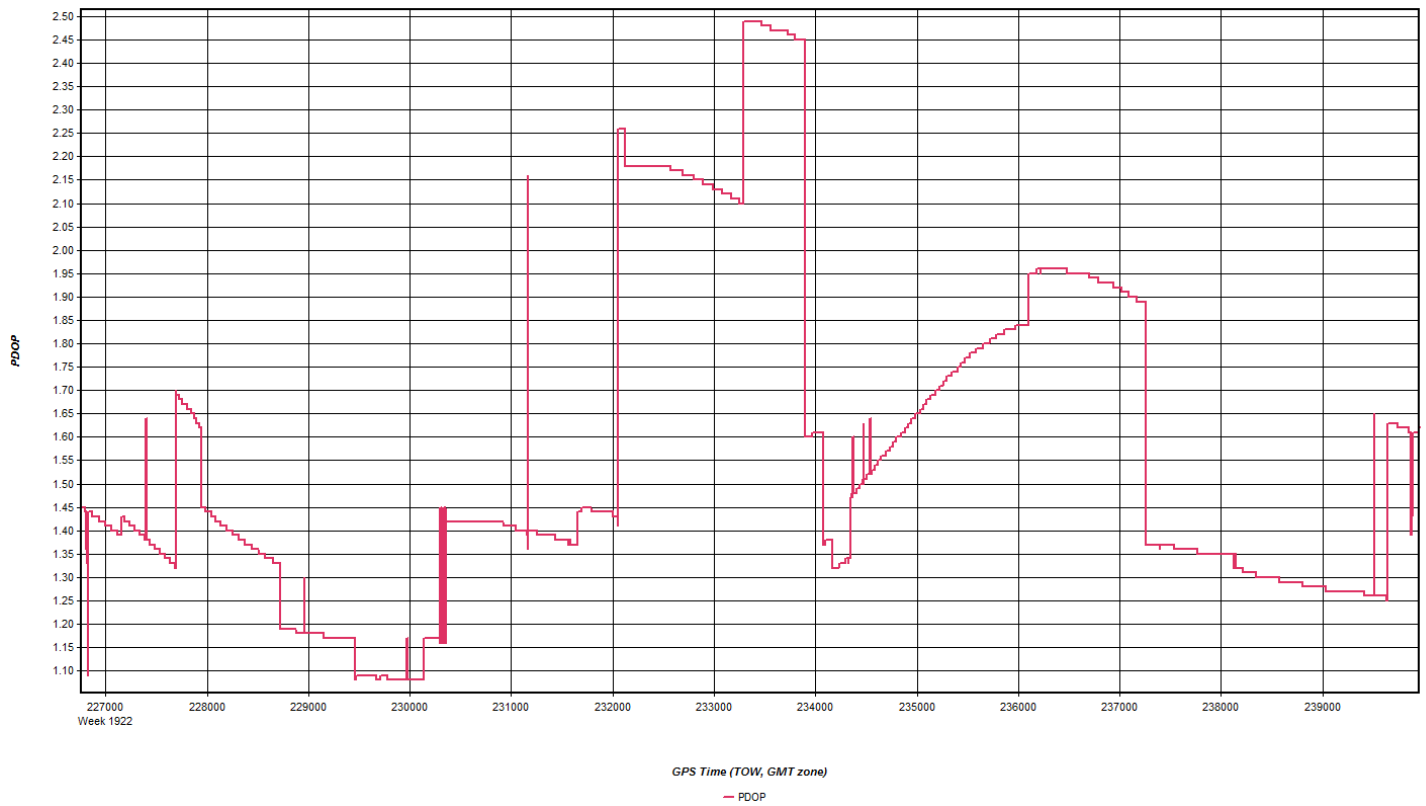

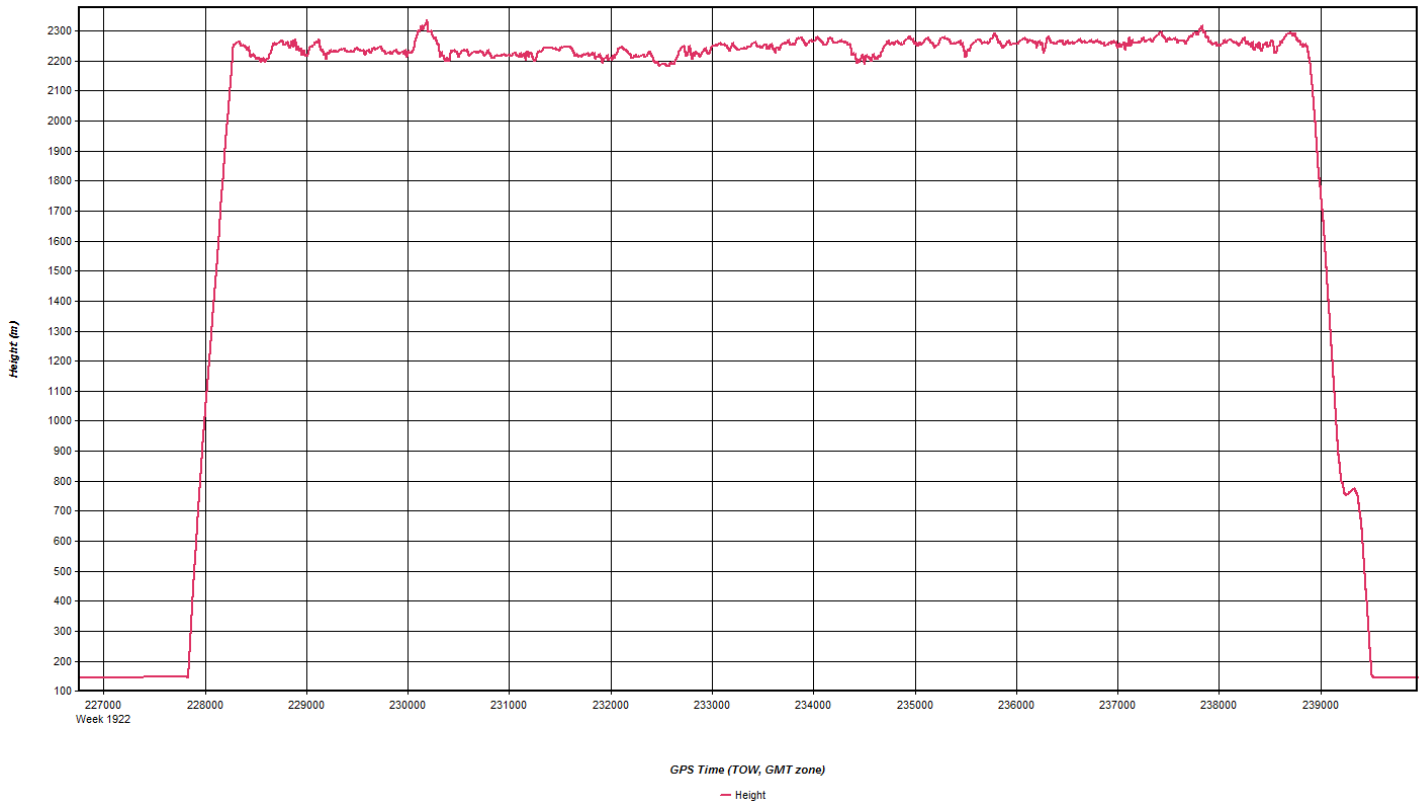
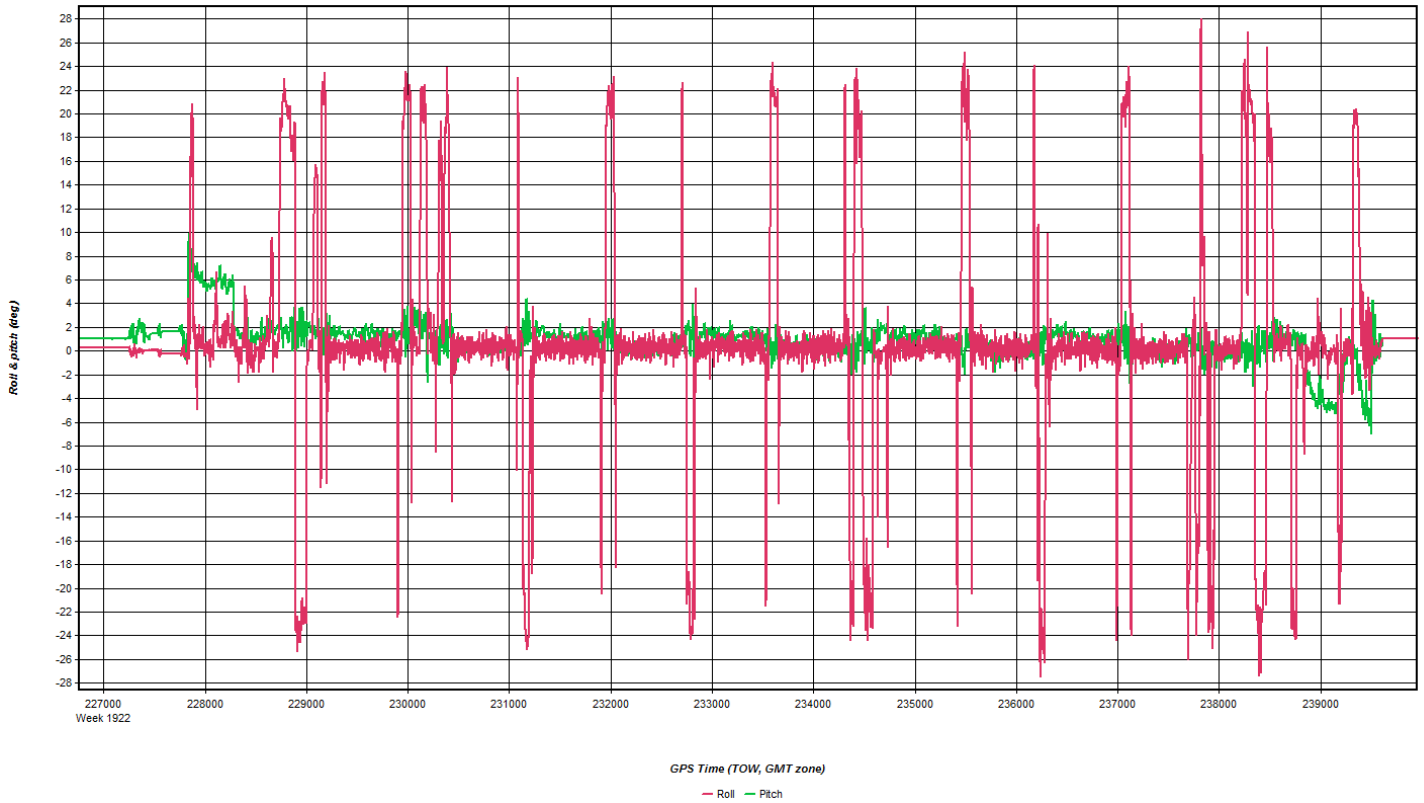

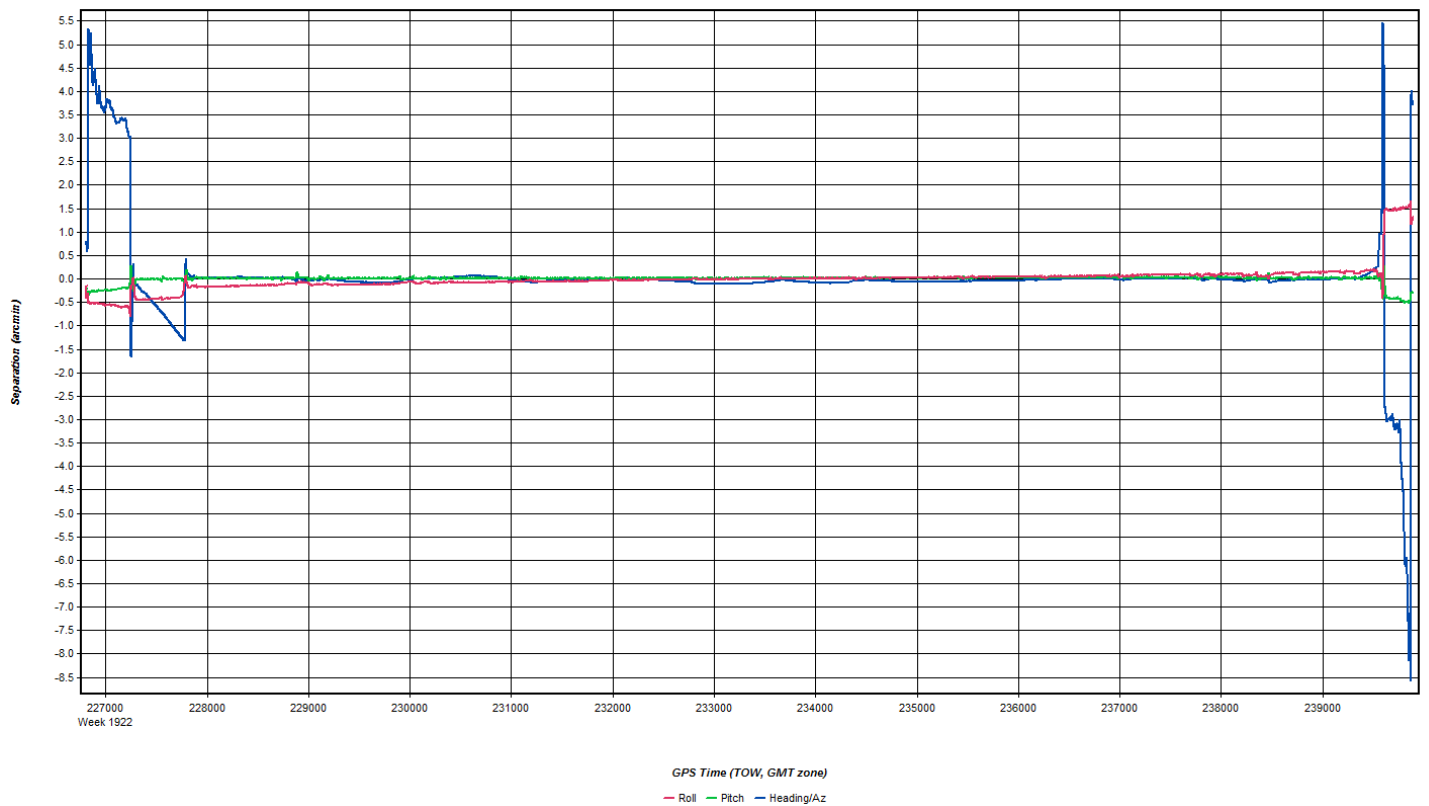
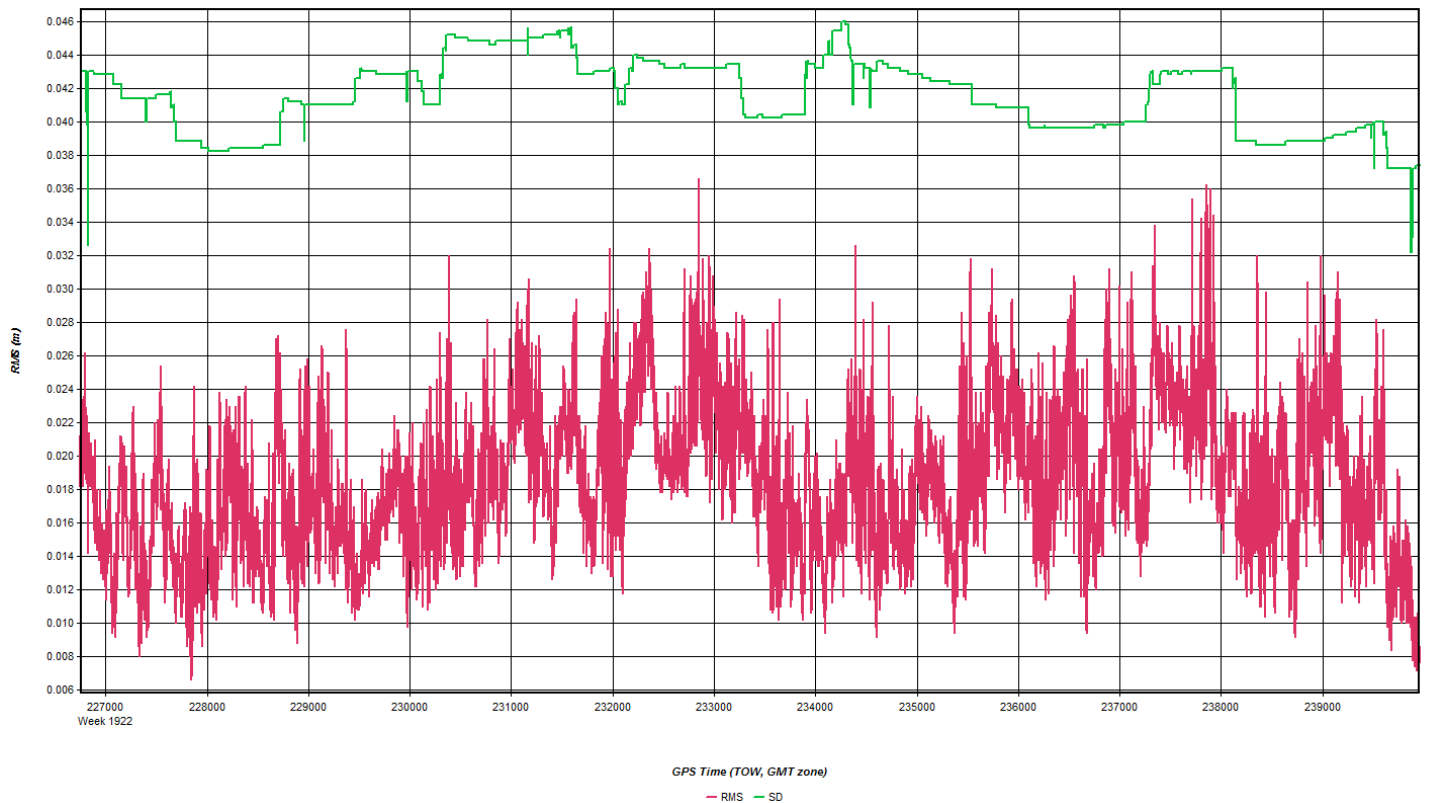

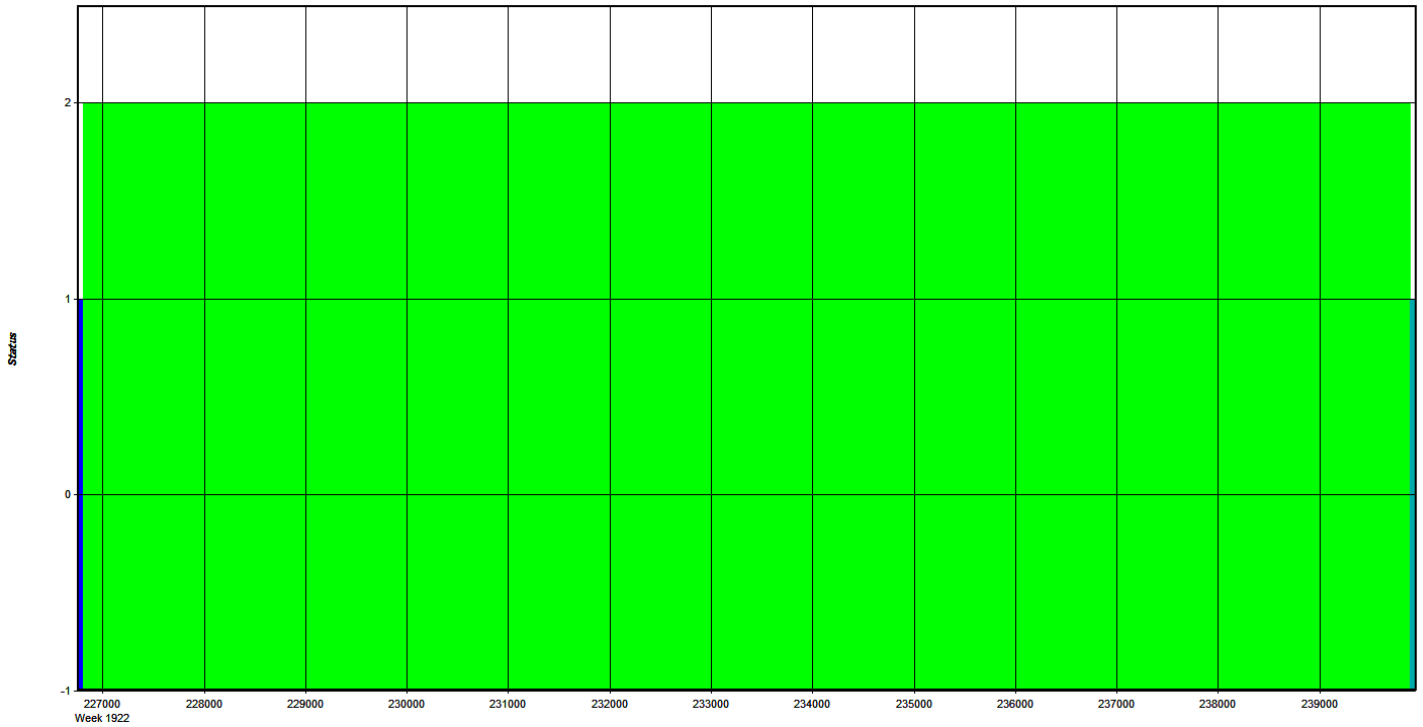

GPS Time (TOW, GMT zone)
 - Float - Forward Fixed - Reverse Fixed - Fixed (2 or more)

Coordinate/Antenna Settings

Master Remote

Base Station
 3: VCAP Name: VCAP Disabled
 File: E:\Proc\29178_VT_CT_River_Basin\20161108_145448\vcap313

Coordinates
 Latitude: North 44 15 43.10641 Compute from PPP
 Longitude: West 72 34 56.55478 Enter Grid Values
 Ellipsoidal height: 160.539 m Enter MSL Height
 Datum: WGS84 Datum Options
 Select From Favorites Add To Favorites Use Average Position

Antenna Height
 From station file: TRM55971.00, NONE View STA File
 Antenna profile: TRM55971.00 Info
 Measured height: 0.000 m
 ARP to L1 offset: 0.067 m
 Applied height: 0.067 m
 Measured to:
 ARP
 L1 Phase Centre
 Compute From Slant

OK Cancel

Coordinate/Antenna Settings
? X

Master
Remote

Base Station

1: VTC1 Name: VTC1 Disabled

File: E:\Proc\29178_VT_CT_River_Basin\20161108_145448\vtc1313

Coordinates

Latitude: North 43 56 21.21809 Compute from PPP

Longitude: West 72 36 12.56537 Enter Grid Values

Ellipsoidal height: 405.144 m Enter MSL Height

Datum: WGS84 Datum Options

Select From Favorites
Add To Favorites
Use Average Position

Antenna Height

From station file: TRM55971.00, NONE View STA File

Antenna profile: TRM55971.00 Info

Measured height: 0.000 m

ARP to L1 offset: 0.067 m

Applied height: 0.067 m

Measured to

ARP

L1 Phase Centre

Compute From Slant

OK
Cancel

Coordinate/Antenna Settings
? X

Master
Remote

Base Station

2: VTRU Name: VTRU Disabled

File: E:\Proc\29178_VT_CT_River_Basin\20161108_145448\vtu313C

Coordinates

Latitude: North 43 36 25.63963 Compute from PPP

Longitude: West 72 58 45.90373 Enter Grid Values

Ellipsoidal height: 161.449 m Enter MSL Height

Datum: WGS84 Datum Options

Select From Favorites
Add To Favorites
Use Average Position

Antenna Height

From station file: TRM57971.00, NONE View STA File

Antenna profile: TRM57971.00 Info

Measured height: 0.000 m

ARP to L1 offset: 0.067 m

Applied height: 0.067 m

Measured to

ARP

L1 Phase Centre

Compute From Slant

OK
Cancel

Flight Log

11-8-16 A mission 29178

Airborne LIDAR Data Collection Log Sheet :: Quantum Spatial, Inc
(email log daily to flight_log_distribution_list@quantumspatial.com)

Date: 11-8-16 A
Lit: A B C D E Pg. 1 of 2

Project: CT RIVER- VT Proj #: 29178 Flight Mgmt File: 20161108-145448 Tech: JSWANN

Aircraft: N226E Begin Hobbs: 8948.6 End Hobbs: 8951.8 Total: 3.2 Pilot: T. Kadlke Co-Pilot: _____ Tot Time Aloft: 3.3

Dep Apt: KLEB Dep Time (Lcl): 1005 (Z): +5 Arr Apt: KLEB Arr Time (Local): 1334 (Z): +5

CORS: (Y) N Sta 1: VTCL Sta 2: _____ Flyovers: (X) N If Y, times: Sta 1) 1527/1817 Sta 2) _____

GPS Unit: Y/N Sta 1: _____ Sta 2: _____ Flyovers: Y/N If Y, times: Sta 1) _____ Sta 2) _____

Gd Temp beg: +2 °C End: _____ °C OAT beg: +7 °C End: +6 °C Altimeter begin: 3017 end: 3007

Type	FOV	Serial #	Scan Freq	Alt AGL	Alt AMSL	MplA Y/N	Pulse In Air	Pulse Rate	Max Gdspd	Power	Avg Pt Spacing PPSM	Storage		
												Mag GB	End GB	Tot GB
LIDAR	40	ALS70	53 Hz	7161		Y/N		260	100%			130	95	017

FLIGHT LINE NOTES - visibility, clouds, smoke, partial, etc

Line #	Hdg	Start (UTC)	End (UTC)	Gd Spd	POOF/STAT	GPS Altitude	Crab	Turb (0-1)
2016	197	1540	1551	158	12/16	7400		0
2015	17							0
2015	17	1601	1610	165	12/15	7325		0
2014	197	1614	1624	153	13/14	7246		0
2013	17	1628	1637	158	12/15	7277		0
2012	197	1641	1651	157	11/15	7268		0
2011	17	1654	1704	158	10/18	7421		0
2010	197	1712	1723	155	10/17	7416		0
2009	17	1726	1735	161	14/14	7425		0
2008	197	1740	1749	149	14/15	7443		0
2007	17	1752	1800	154	12/14	7430		0
X16	107	1805	1809	171	12/16	7399		0
		1817	1834					

KLEB → VTCL - 1527Z - fig 85 @ 1532

Aborted for traffic 1554

Delayed for Traffic

Figure 85 @ 1811 - VTCL Flyover @ 1817

RTB side → KLEB - Fueling

mob time = 0.7

On line time = 2.5

Hobbs time = 3.2

Online Time: 2.5

Lines Flow: 10

Lines Remain: 0

Total Prof Lines: 10

Notes:

Nov 8, 2016-A (N73TM, SN7178)

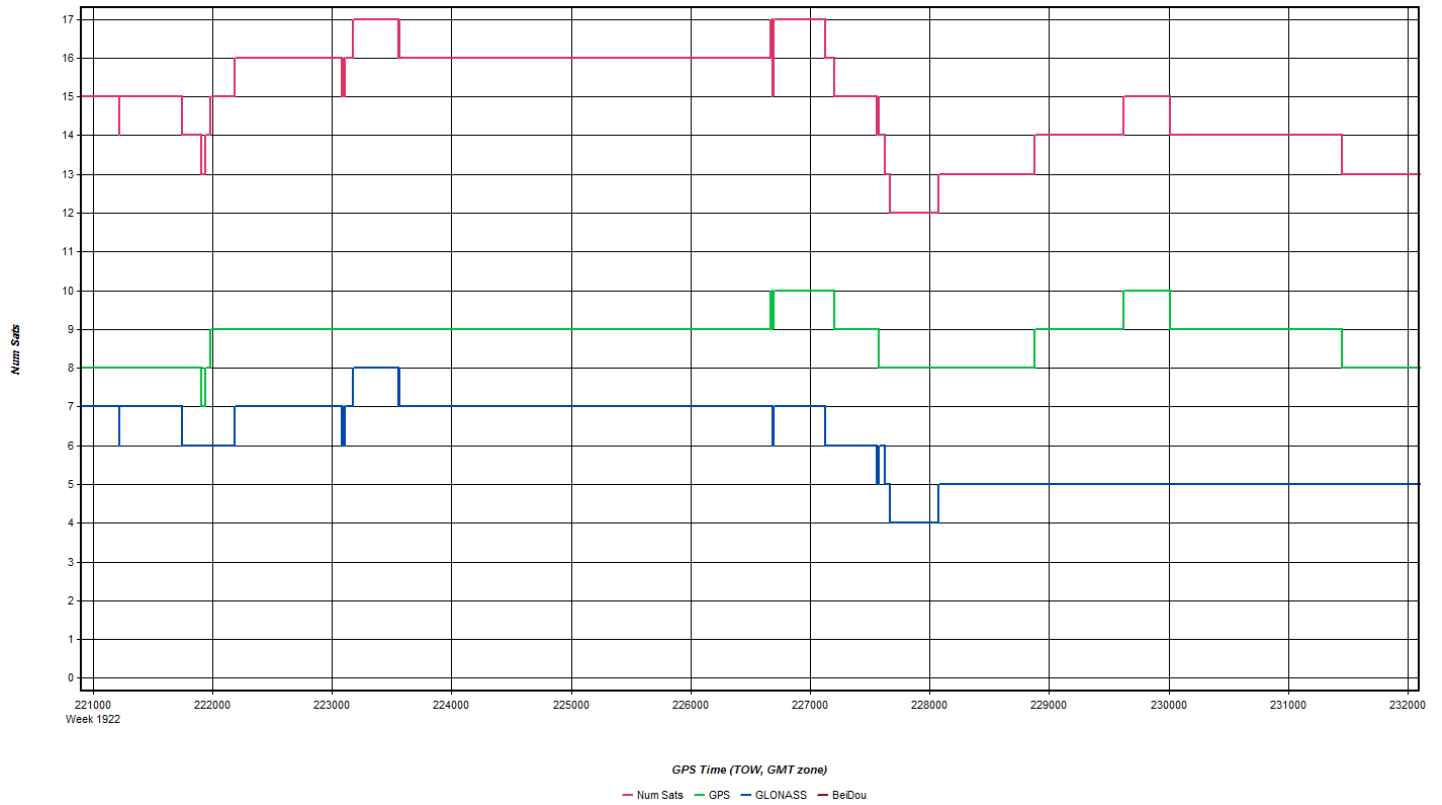
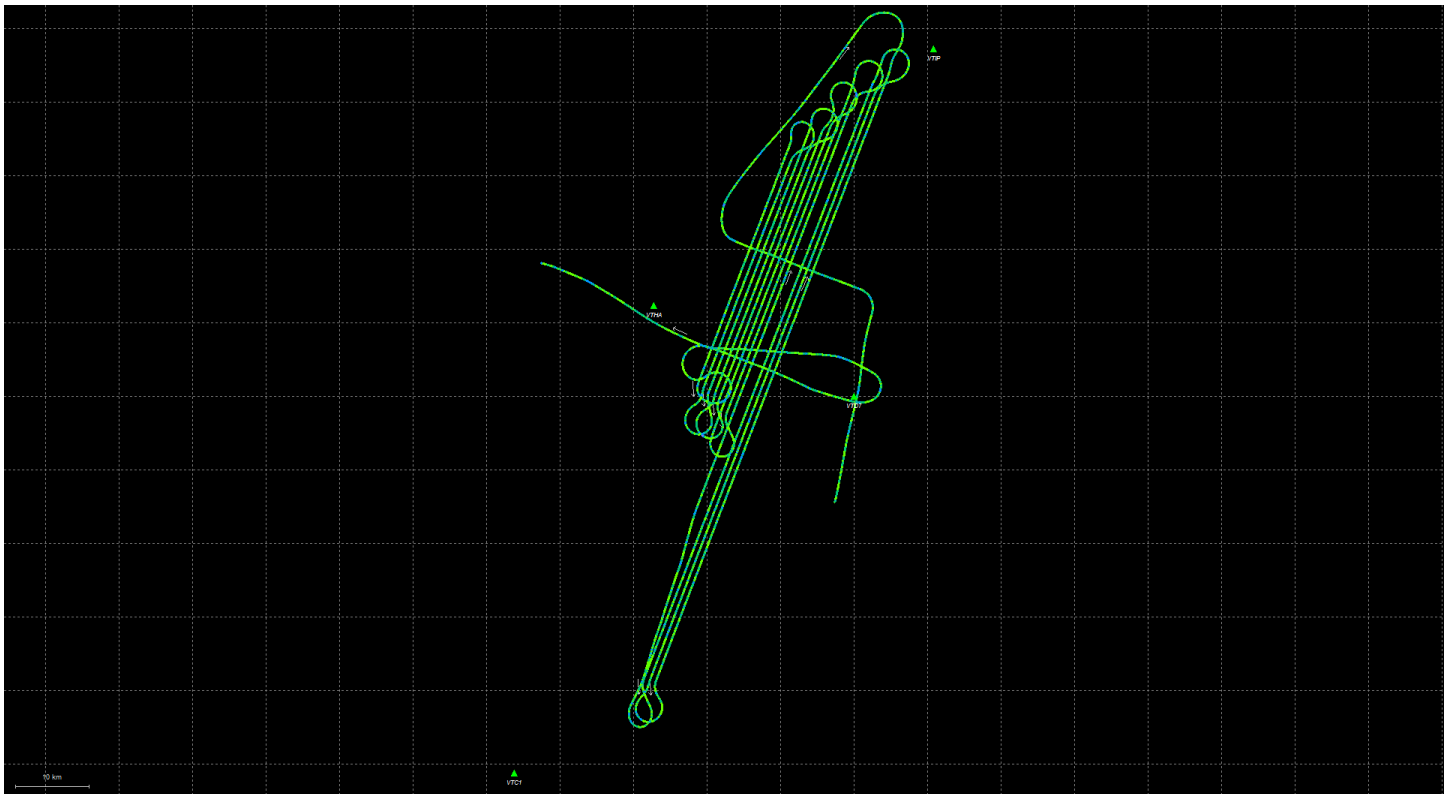

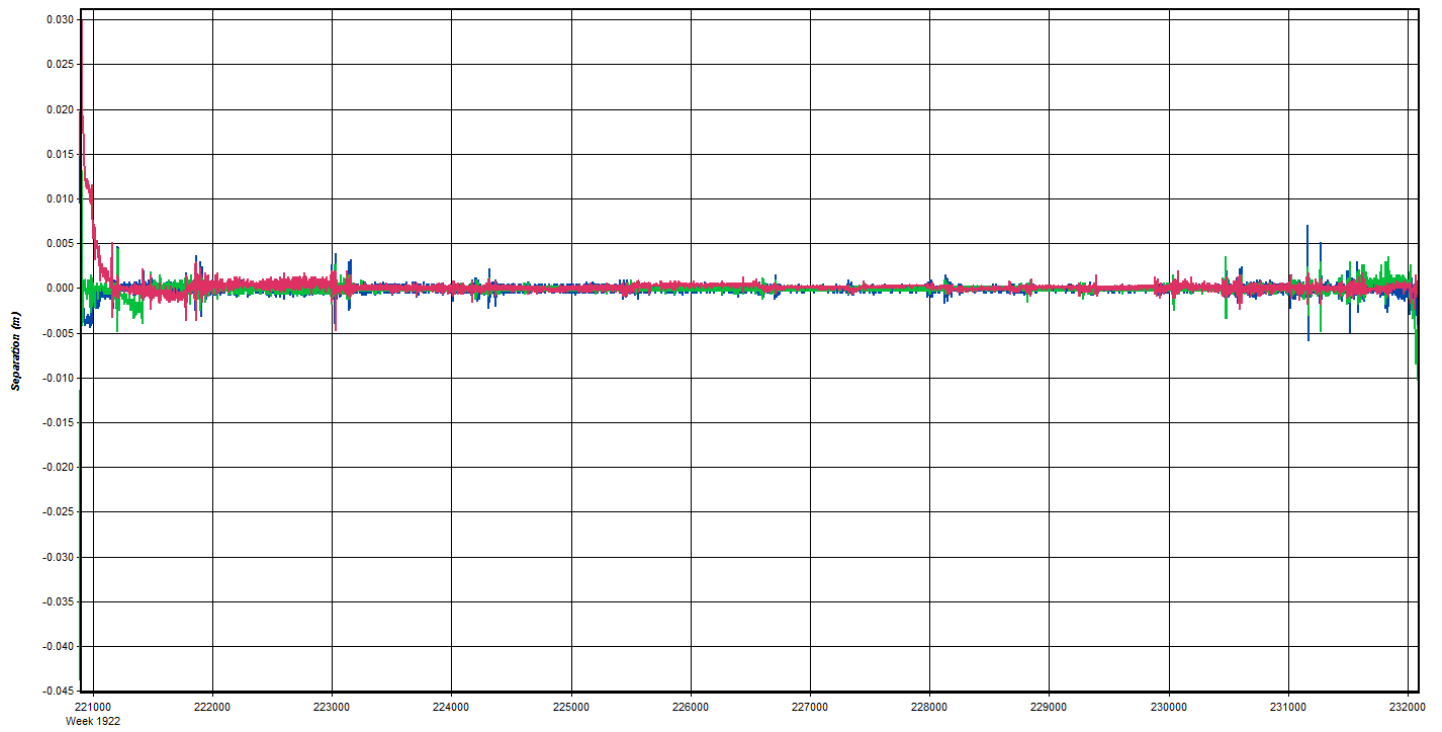

GPS Time (TOW, GMT zone)
— East — North — Up

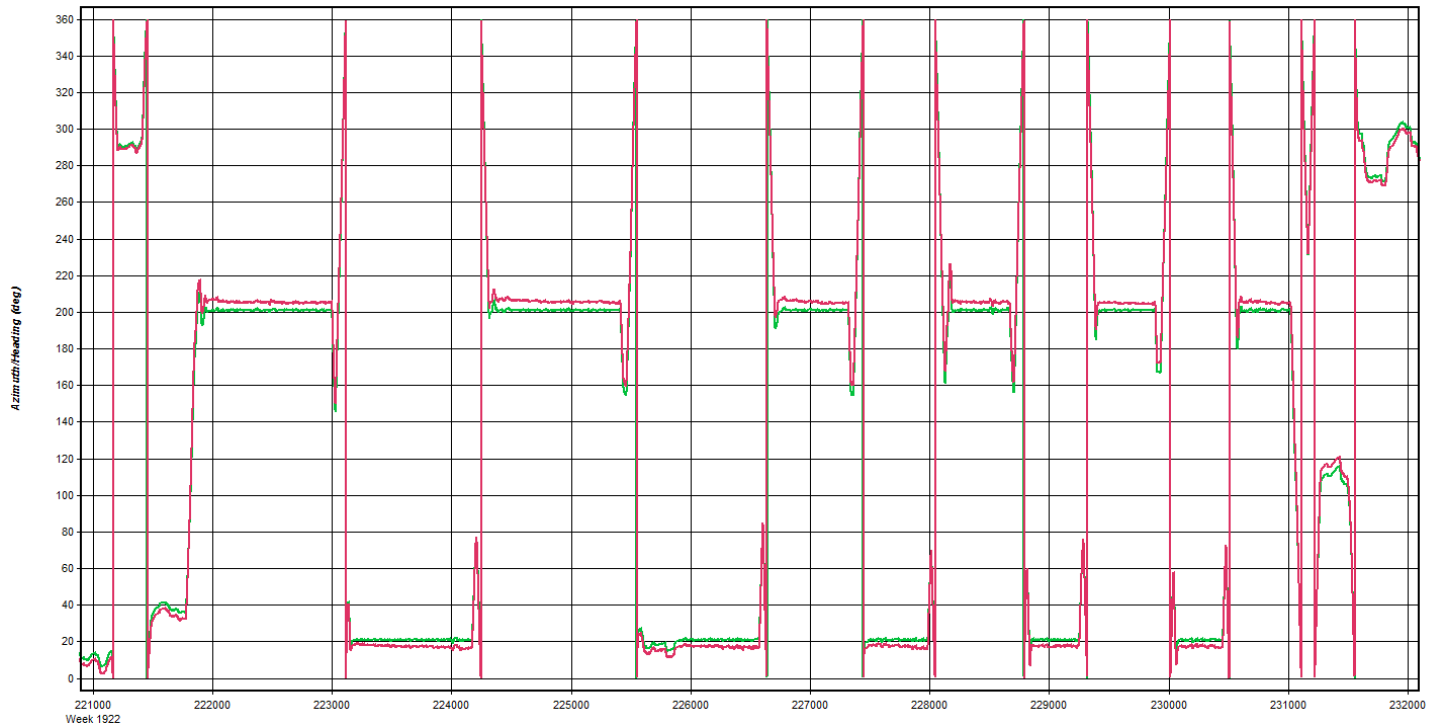

GPS Time (TOW, GMT zone)
— Heading/Azimuth — GPS-COG

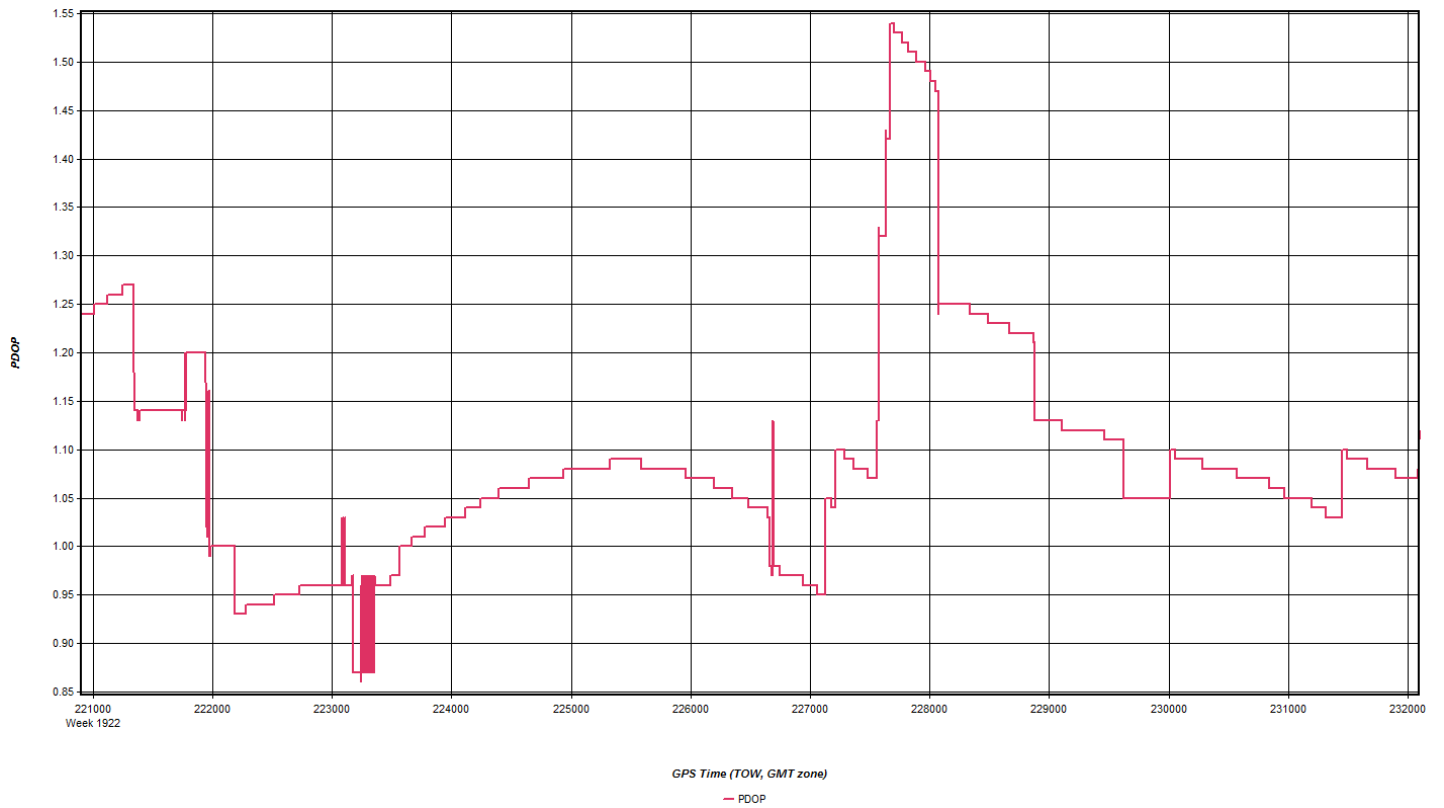

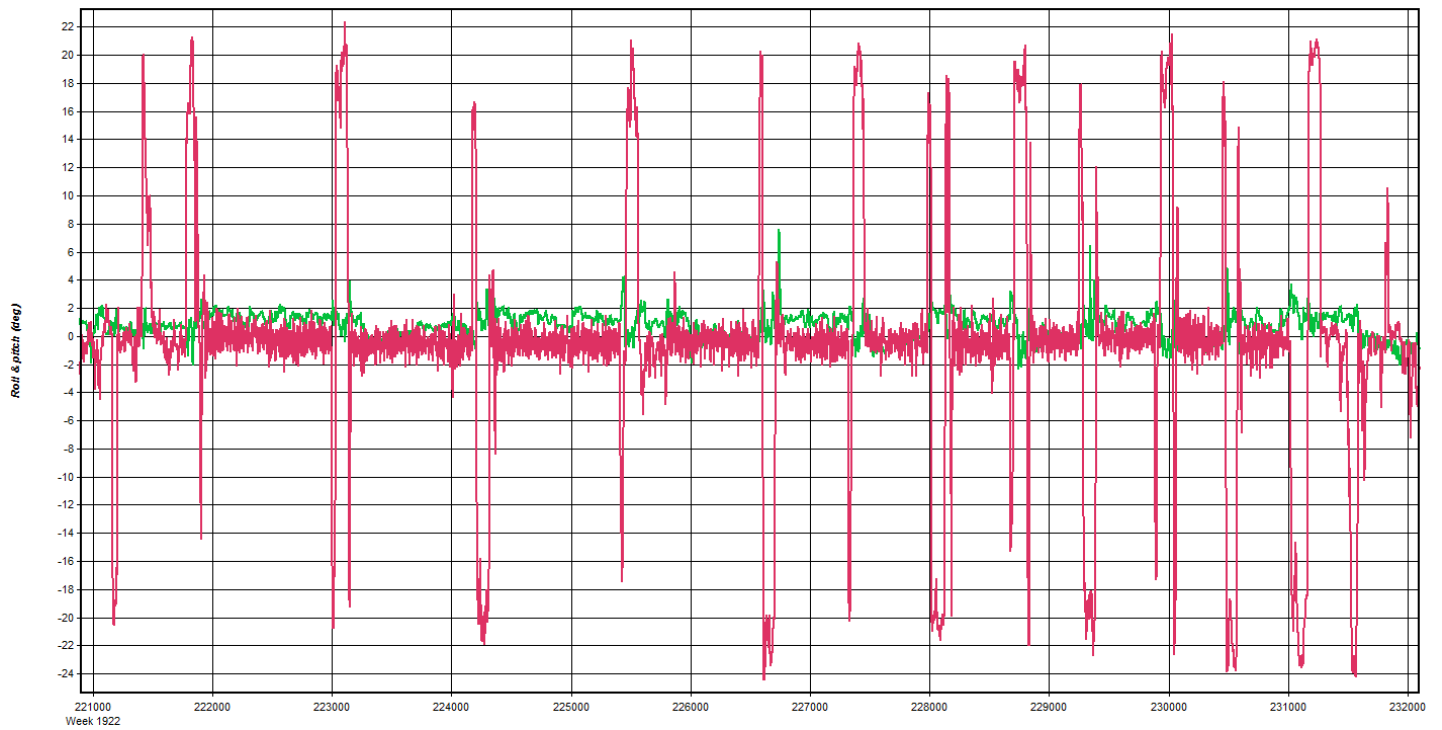

GPS Time (TOW, GMT zone)

— Roll — Pitch

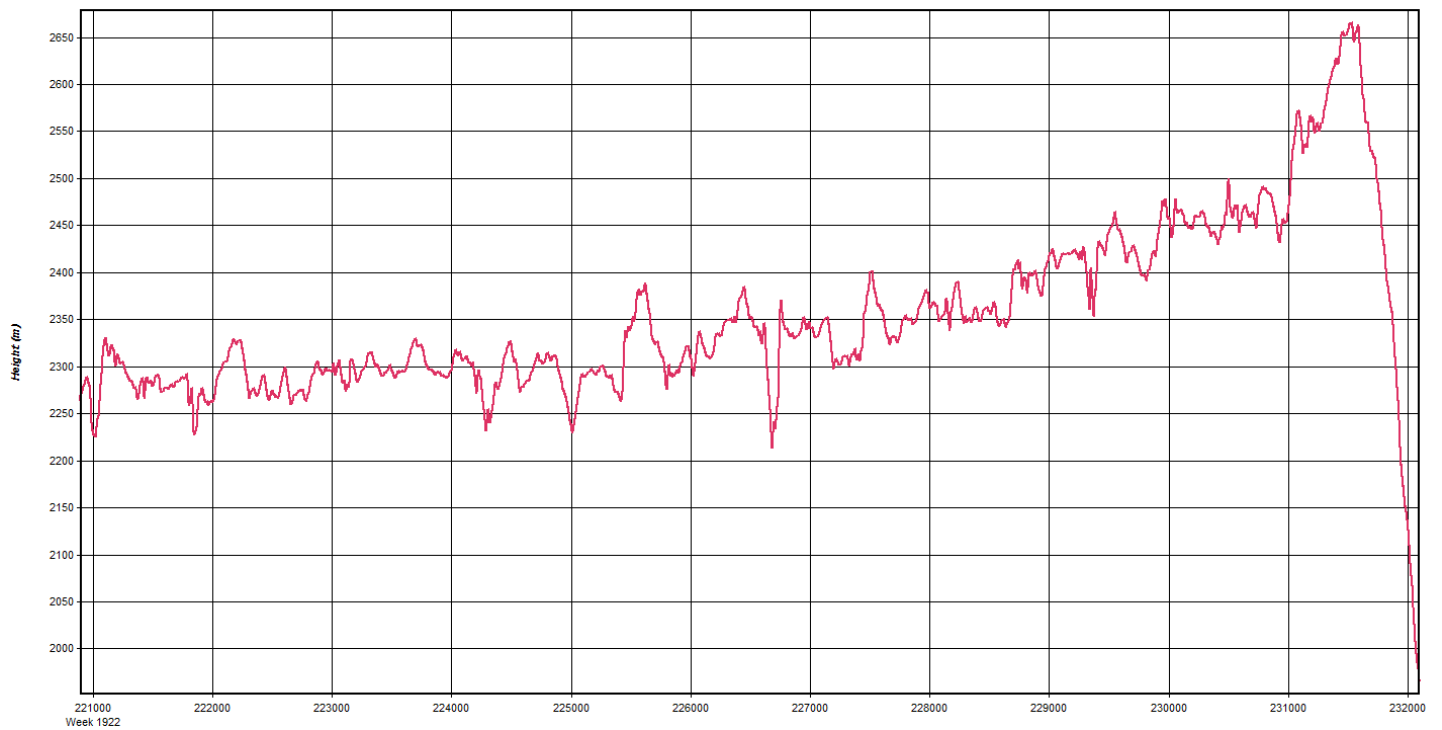

GPS Time (TOW, GMT zone)

— Height

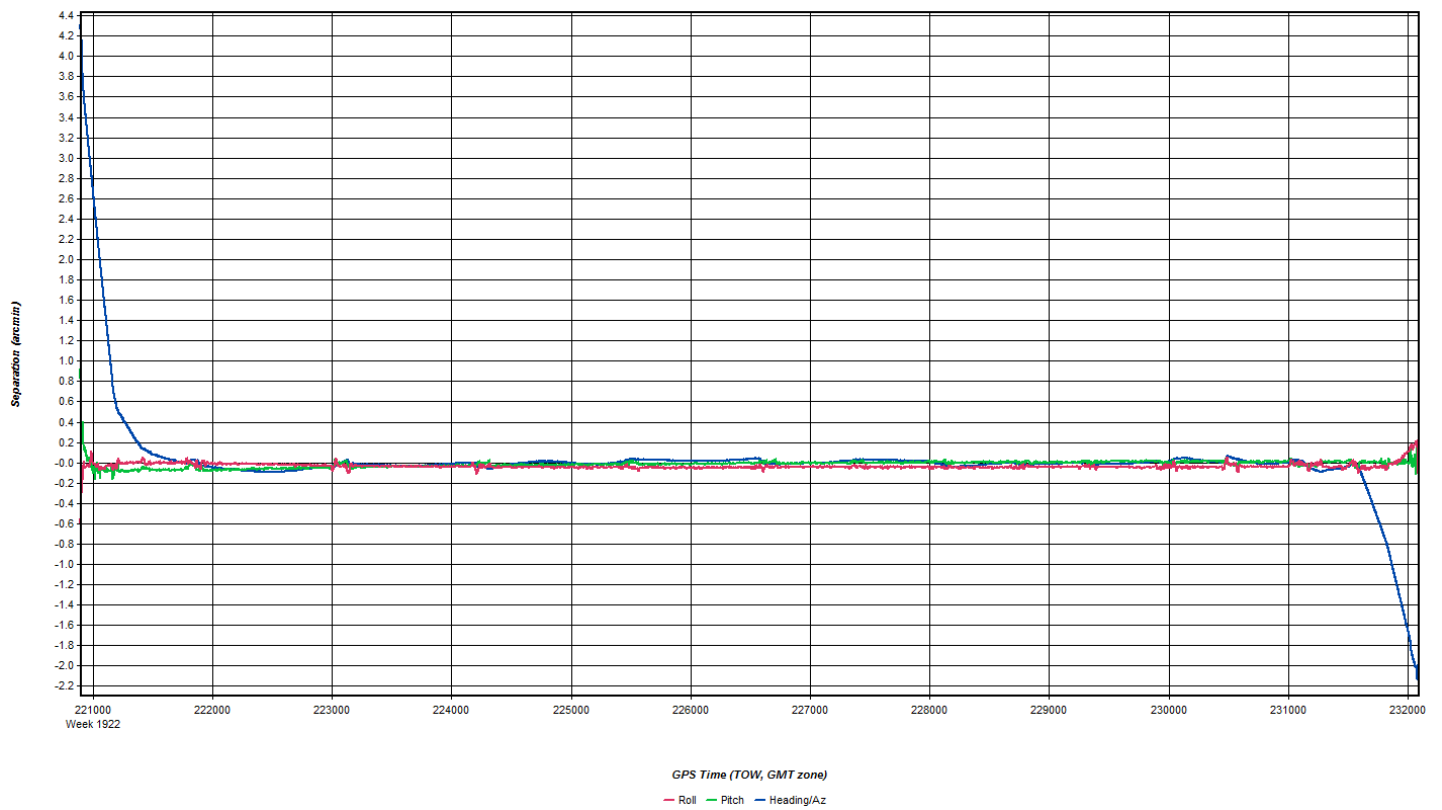
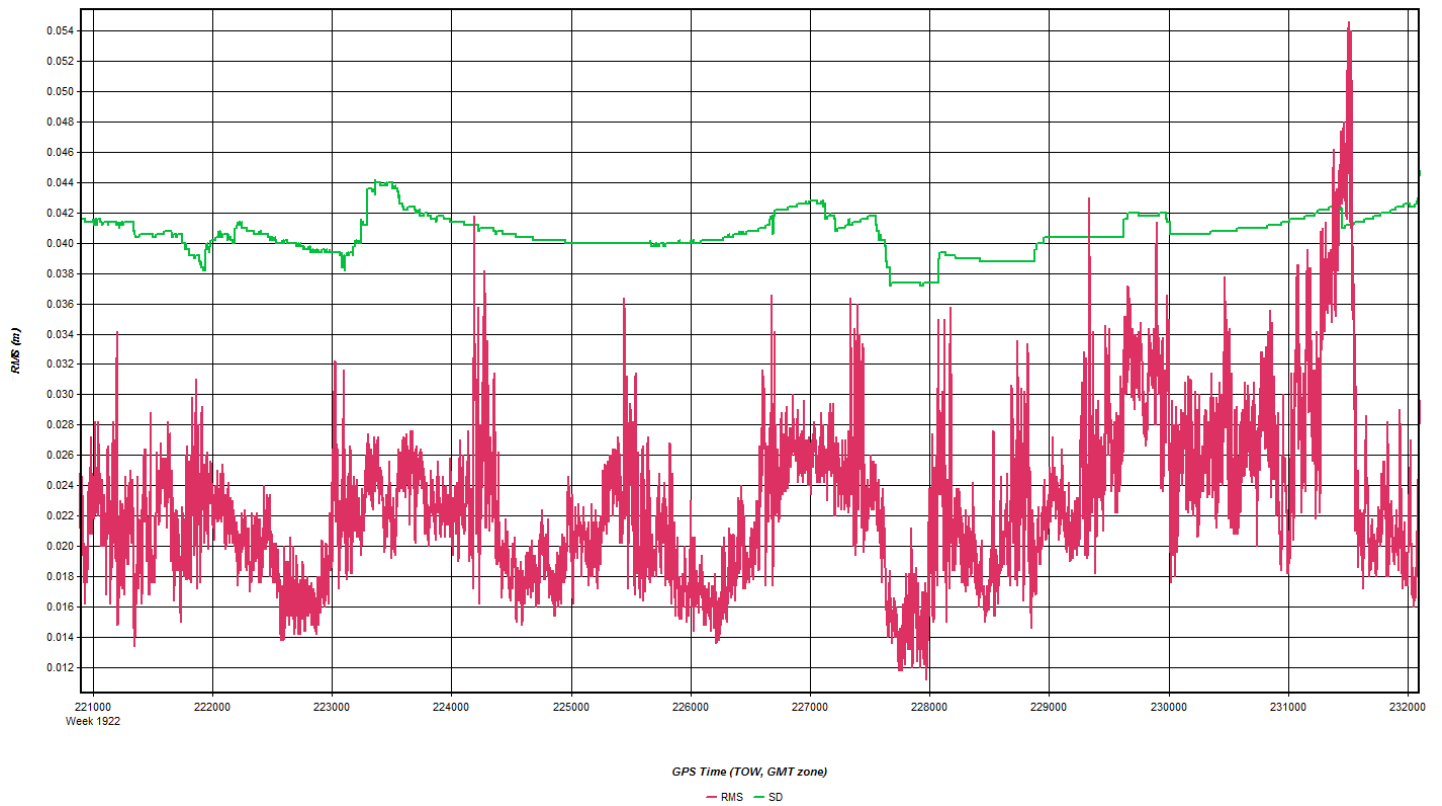

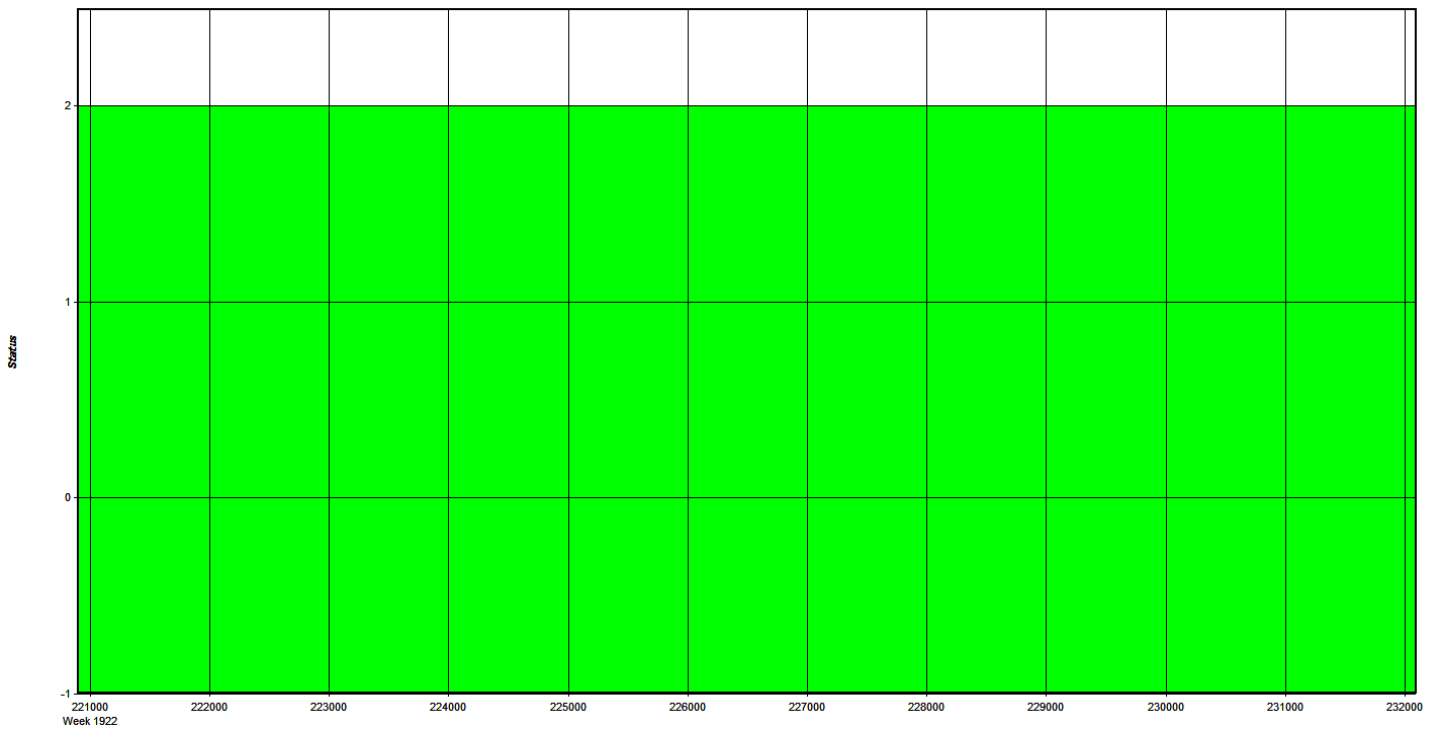

GPS Time (TOW, GMT zone)
 - Float - Forward Fixed - Reverse Fixed - Fixed (2 or more)

Coordinate/Antenna Settings

Master Remote

Base Station
 4: VTC1 Name: VTC1 Disabled
 File: E:\Proc\29178_VT_CT_River_Basin\20161108_AB_29178_ALS7

Coordinates
 Latitude: North 43 56 21.21809 Compute from PPP
 Longitude: West 72 36 12.56537 Enter Grid Values
 Ellipsoidal height: 405.144 m Enter MSL Height
 Datum: WGS84 Datum Options
 Select From Favorites Add To Favorites Use Average Position

Antenna Height
 From station file: TRM55971.00, NONE View STA File
 Antenna profile: TRM55971.00 Info
 Measured height: 0.000 m
 ARP to L1 offset: 0.067 m
 Applied height: 0.067 m
 Measured to
 ARP
 L1 Phase Centre
 Compute From Slant

OK Cancel

Coordinate/Antenna Settings
? X

Master
Remote

Base Station

1: VTD7

Disabled

File: E:\Proc\29178_VT_CT_River_Basin\20161108_AB_29178_ALS7

Coordinates

Latitude:	North	44	23	52.31066	Compute from PPP
Longitude:	West	72	01	32.39267	Enter Grid Values
Ellipsoidal height:		166.528	m		Enter MSL Height
Datum:		WGS84			Datum Options

Antenna Height

From station file: TRM55971.00, NONE

Antenna profile: TRM55971.00

Measured height: 0.000 m

ARP to L1 offset: 0.067 m

Applied height: 0.067 m

Measured to

ARP

L1 Phase Centre

Coordinate/Antenna Settings
? X

Master
Remote

Base Station

2: VTHA

Disabled

File: E:\Proc\29178_VT_CT_River_Basin\20161108_AB_29178_ALS7

Coordinates

Latitude:	North	44	30	30.69556	Compute from PPP
Longitude:	West	72	21	57.16354	Enter Grid Values
Ellipsoidal height:		256.821	m		Enter MSL Height
Datum:		WGS84			Datum Options

Antenna Height

From station file: TRM57971.00, NONE

Antenna profile: TRM57971.00

Measured height: 0.000 m

ARP to L1 offset: 0.067 m

Applied height: 0.067 m

Measured to

ARP

L1 Phase Centre

Coordinate/Antenna Settings ? X

Master Remote

Base Station
3: VTIP Name: VTIP Disabled
File: E:\Proc\29178_VT_CT_River_Basin\20161108_AB_29178_ALS7

Coordinates
Latitude: North 44 49 12.18043 Compute from PPP
Longitude: West 71 53 25.83872 Enter Grid Values
Ellipsoidal height: 341.732 m Enter MSL Height
Datum: WGS84 Datum Options
Select From Favorites Add To Favorites Use Average Position

Antenna Height
From station file: TRM55971.00, NONE View STA File
Antenna profile: TRM55971.00 Info
Measured height: 0.000 m
ARP to L1 offset: 0.067 m
Applied height: 0.067 m
Measured to:
 ARP
 L1 Phase Centre
Compute From Slant

OK Cancel

Flight Log

Date: 11-8-16 Pg. 1 of 1

(email: Log daily to flight_log_distribution_list@quantumspatial.com)

Project: USGS CT RIVER BASIN Proj #: 29178 Flight Mgmt File: 29178_USGS_WINDSOR_5N7178_161108_128258

Aircraft: N73TM Begin Hobbs: 6474.7 End Hobbs: 6474.7 Total: 3.6 Pilot: BIKUNTON Co-Pilot: Tech: MOODY

Dep Apt: ZEB Dep Time (Lcl): 0805 (Z): 1305 Arr Apt: BTY Arr Time (Local): 1139 (Z): 1639 Tot Time Aloft: 3:35

CORS: Y/N Sta 1: VT57 Sta 2: Flyovers: Y/N IF Y, times: Sta1) 1323, 1618 Sta2) Flyovers: Y/N IF Y, times: Sta1) Sta2)

GPS Unit: Y/N Sta 1: Sta 2: Altimeter begin: end: Storage Name

Gd Temp beg: °C End: °C OAT beg: °C End: °C Avg Terr Ht Max Gdspd Power Avg Pct Spacing PPSM Bag CB End CB Tot CB GB 7170 5533

Line #	Hdg	Start (UTC)	End (UTC)	Gd Spd	POB/Plans	GPS Altitude	Crab	Turb (0-4)	Alt		Pulse In Air	Pulse Rate	26.0 # kHz	Power	100%
									AMS	AGL					
2014	291	1326	1329	173	1.1/17	7550	0	0							
2013	021	1359	1415	159	1.0/19	7420	19	0							
2012	201	1419	1436	155	1.2/17	7520		0							
2009	021	1446	1457	164	1.2/17	7520		0							
2008	021	1511	1519	160	1.1/17	7650		0							
2007	201	1523	1530	158	1.0/18	7830		0							
2006	021	1533	1540	165	0.9/19	7710	4	0							
2005	201	1544	1551	152	1.1/16	7880	5	0							
2004	021	1554	1600	166	1.1/16	7970	7	0							
2003	201	1603	1609	155	1.1/16	8090	8	0							
					1.2/15	8080	9	0							

FLIGHT LINE NOTES - visibility, clouds, smoke, partial, etc.

Total Proj Lines: Lines Flown: Online Time: 2.75 Mob Time: 0.75 Notes:

Nov 8, 2016-B (N22GE, SN7161)

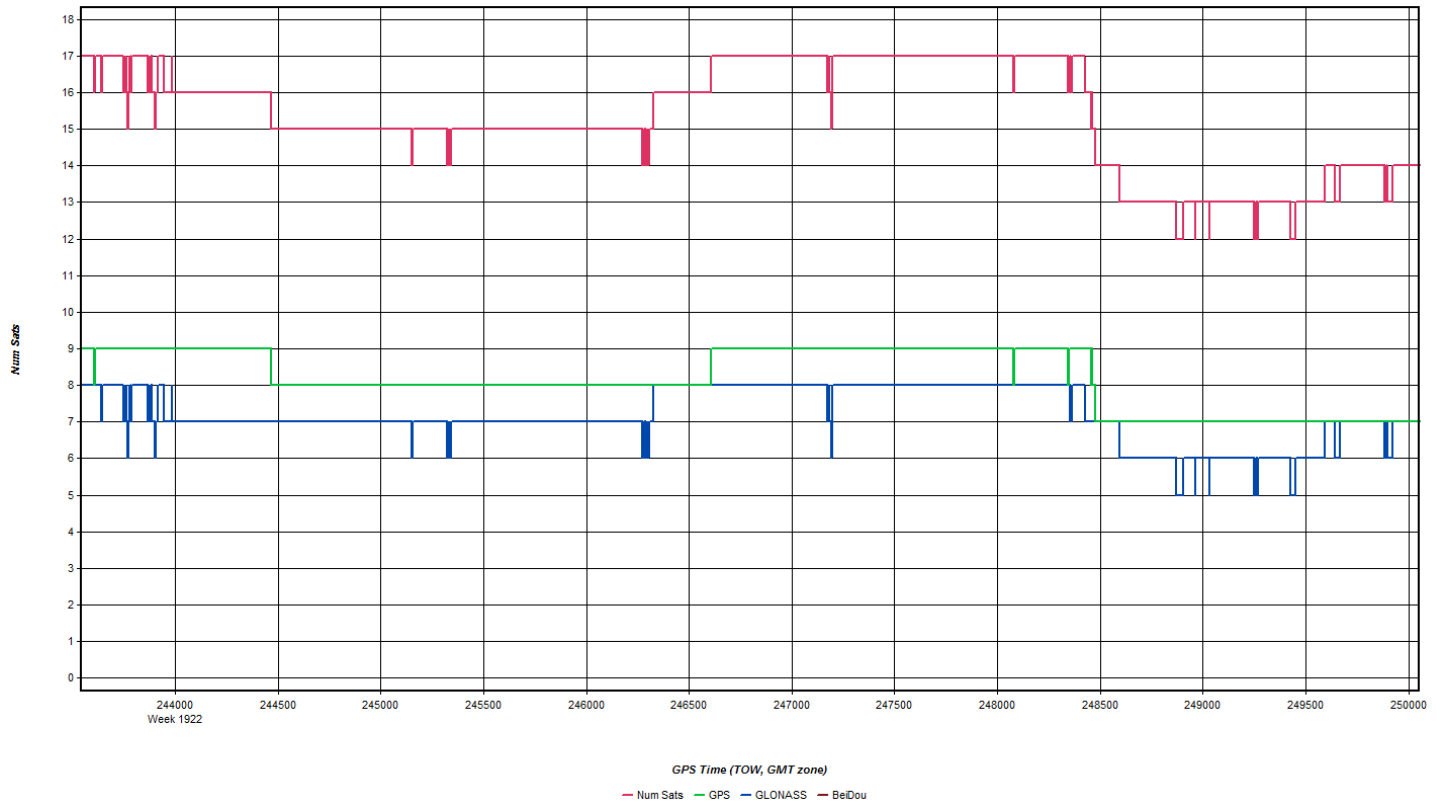
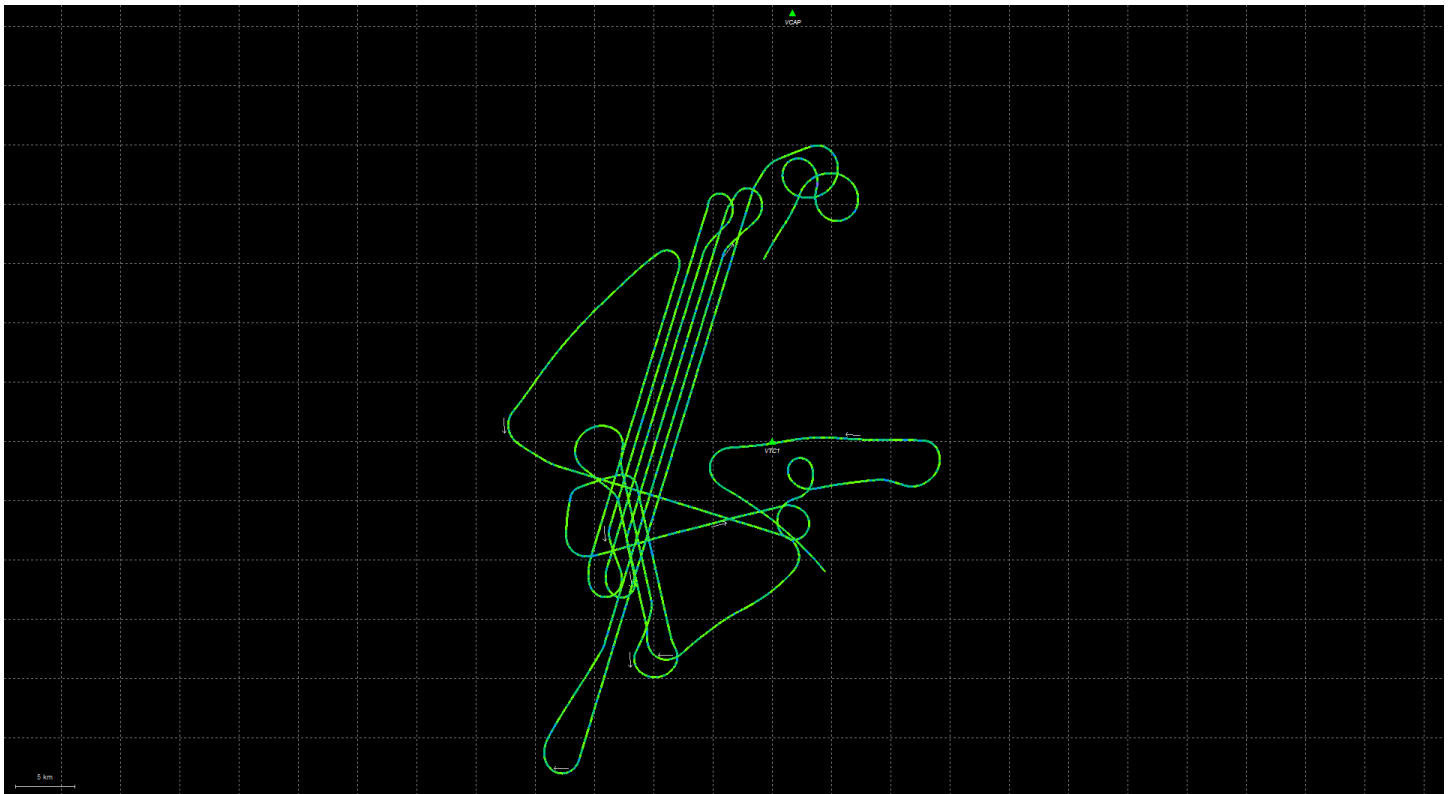

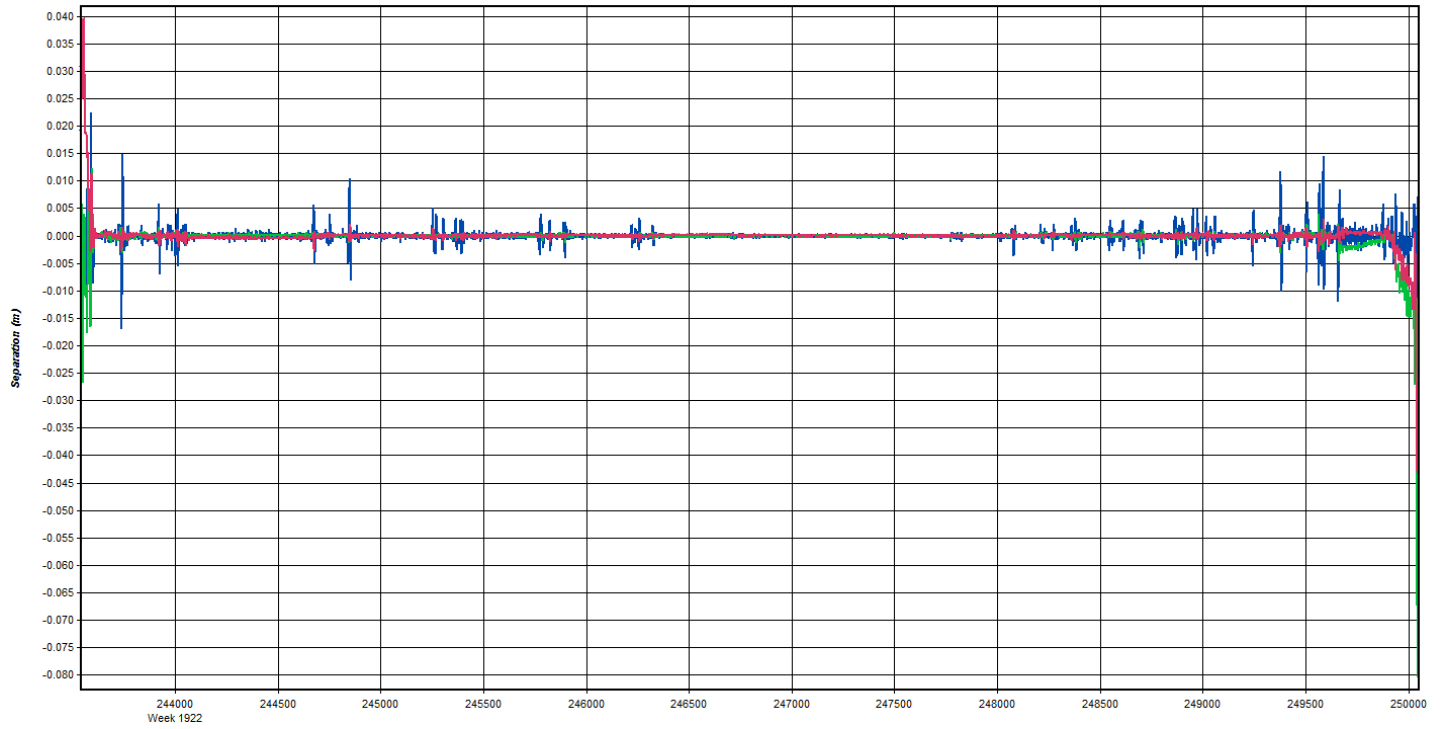

GPS Time (TOW, GMT zone)
— East — North — Up

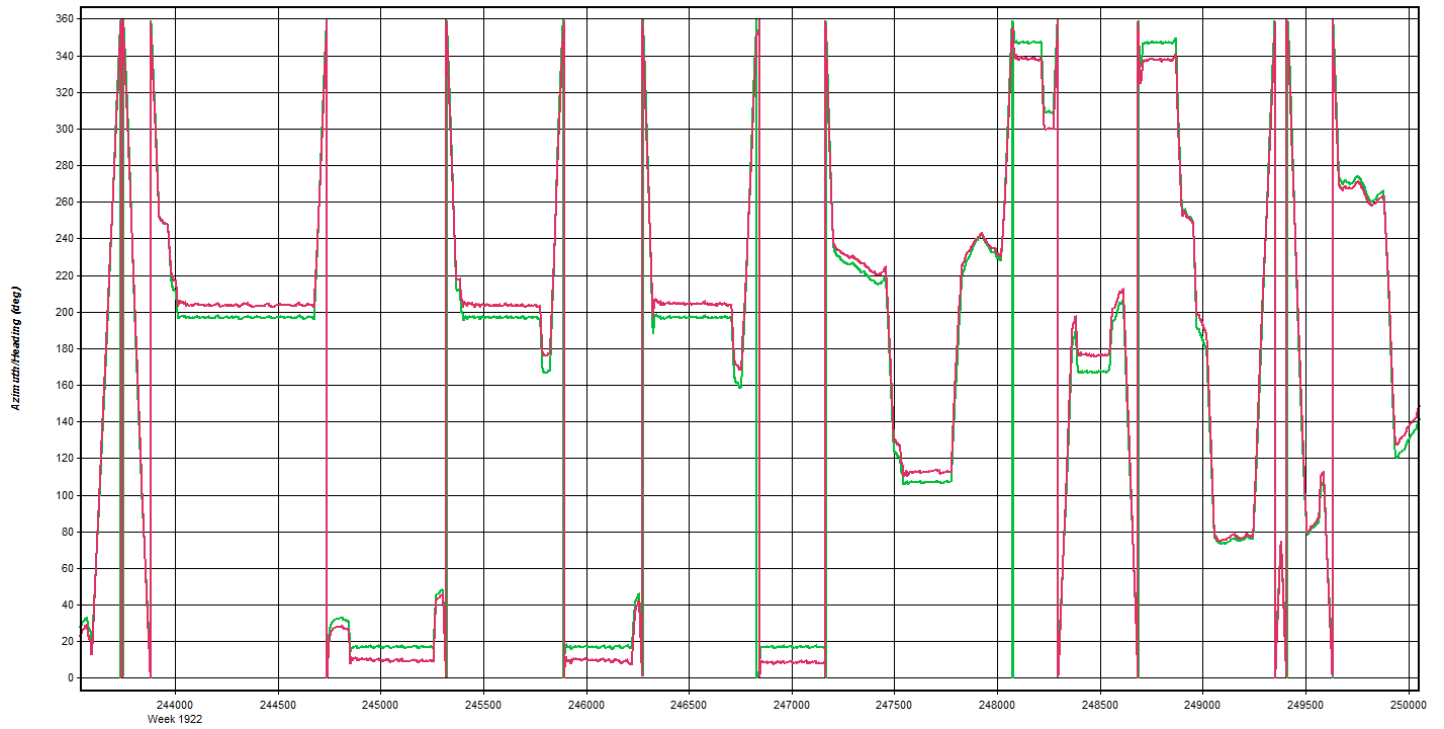

GPS Time (TOW, GMT zone)
— Heading/Azimuth — GPS-COG

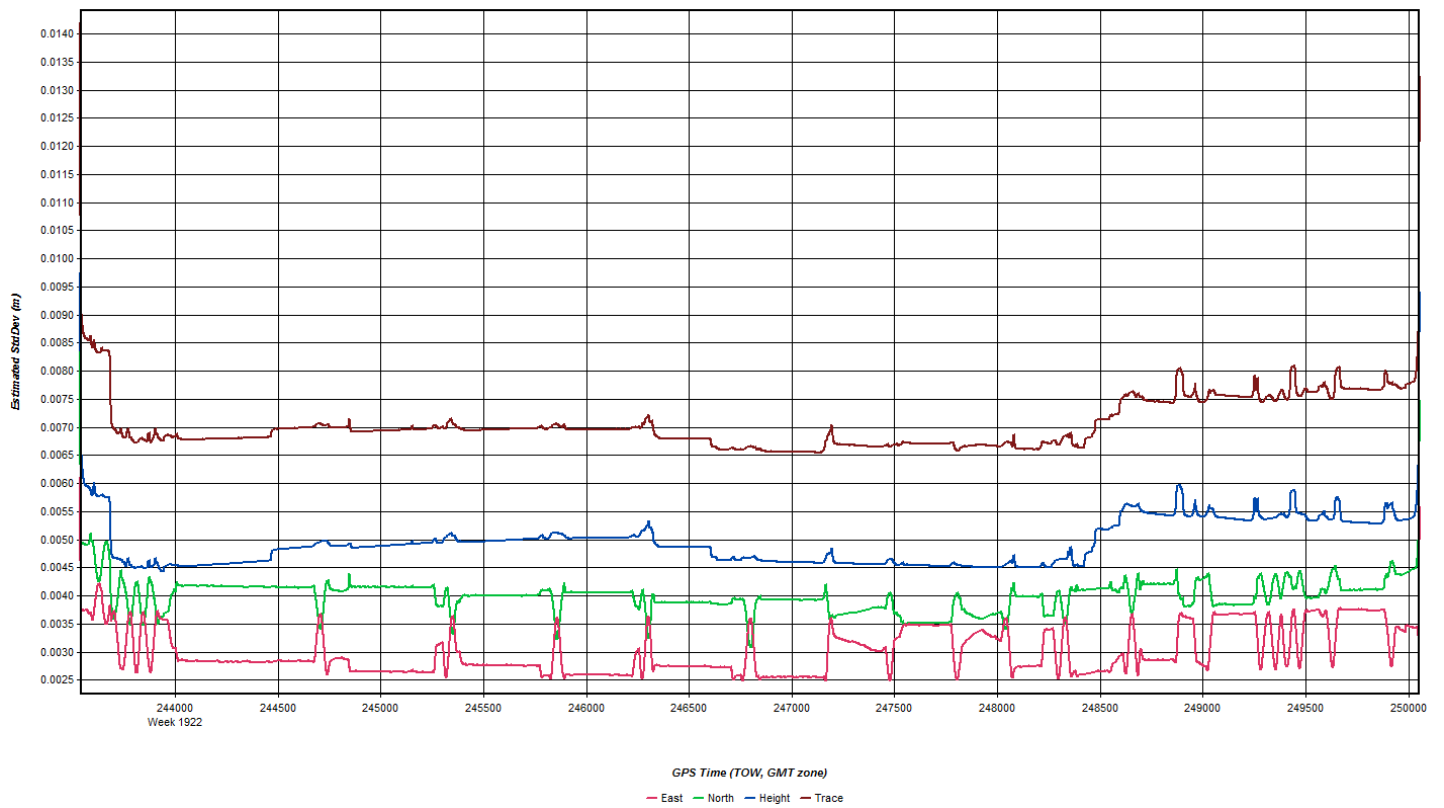

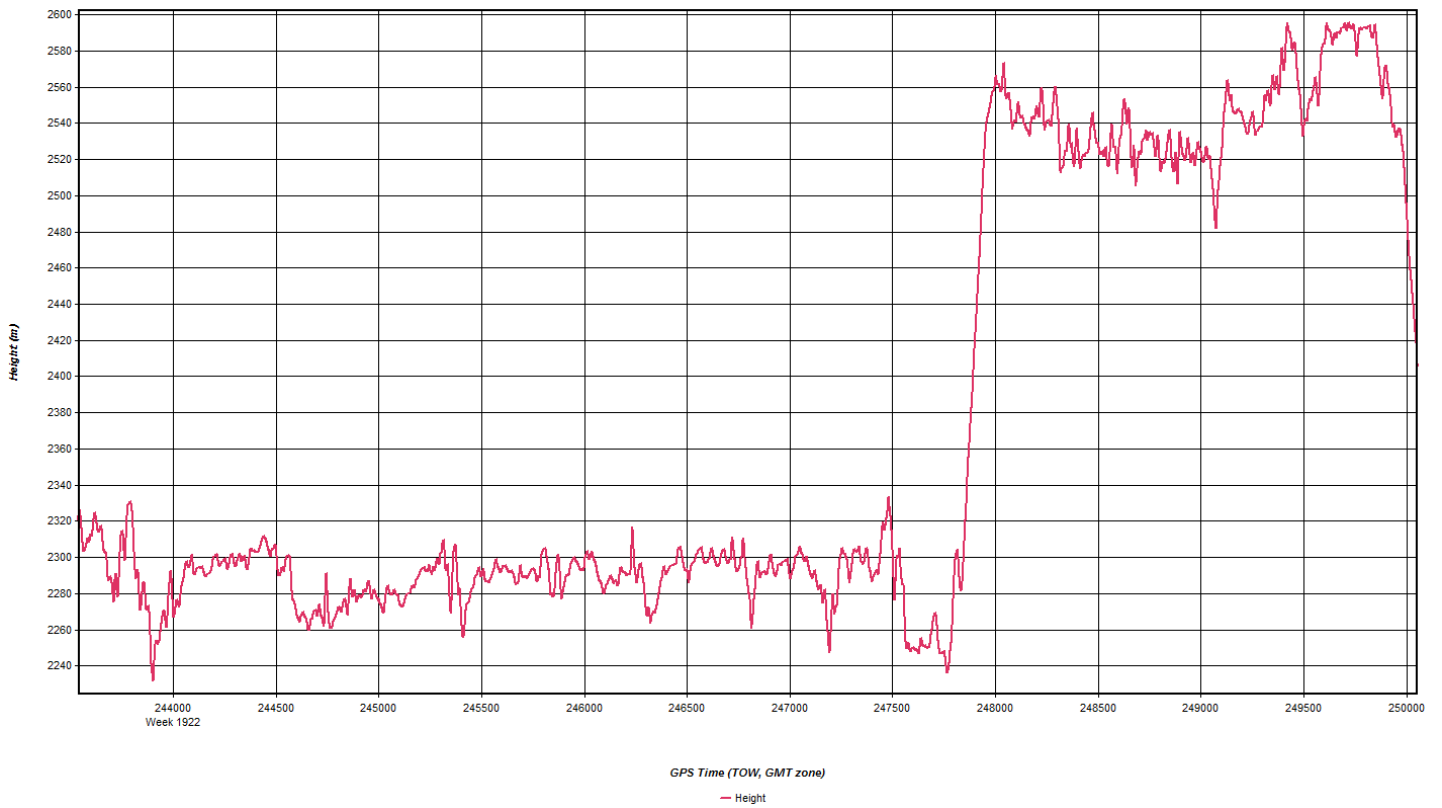
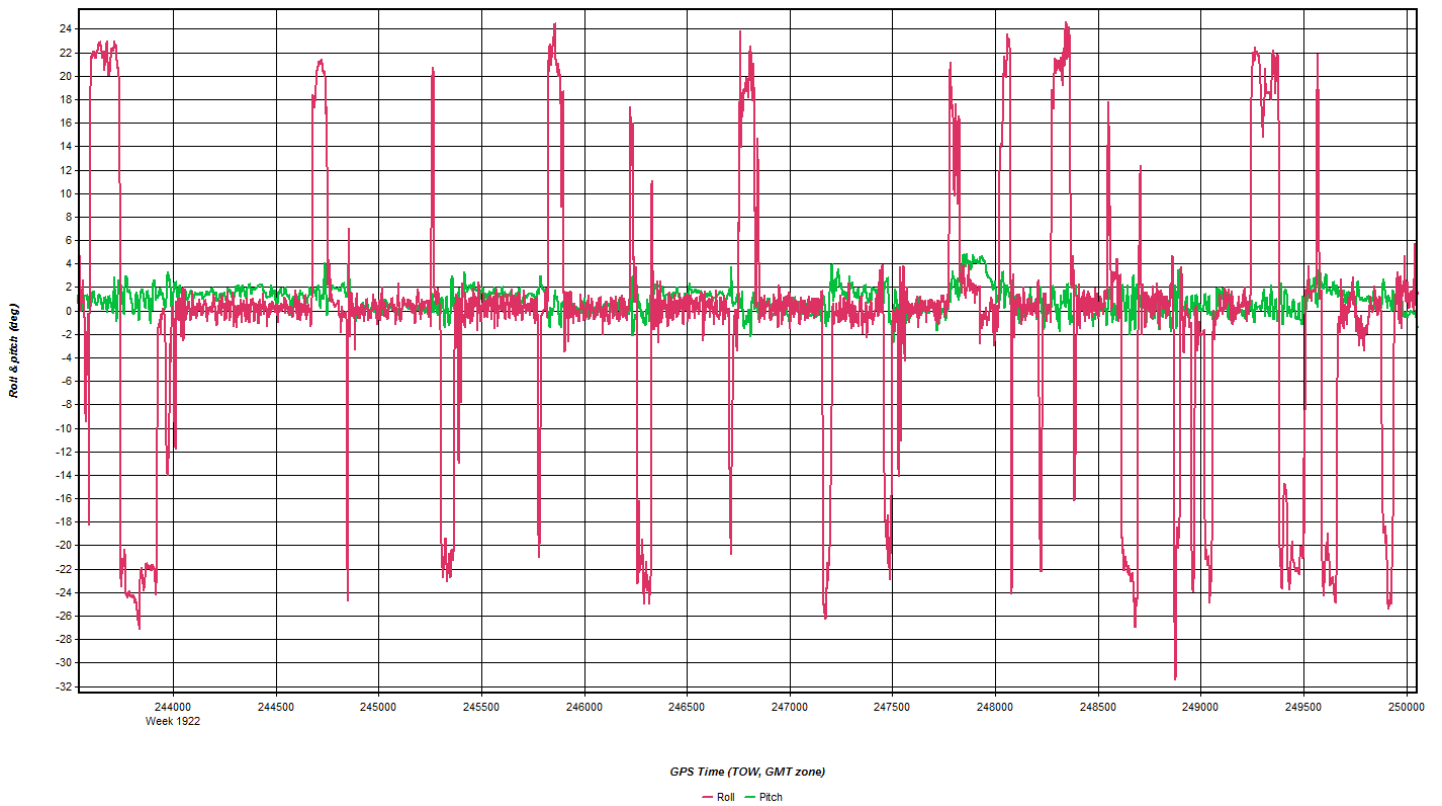

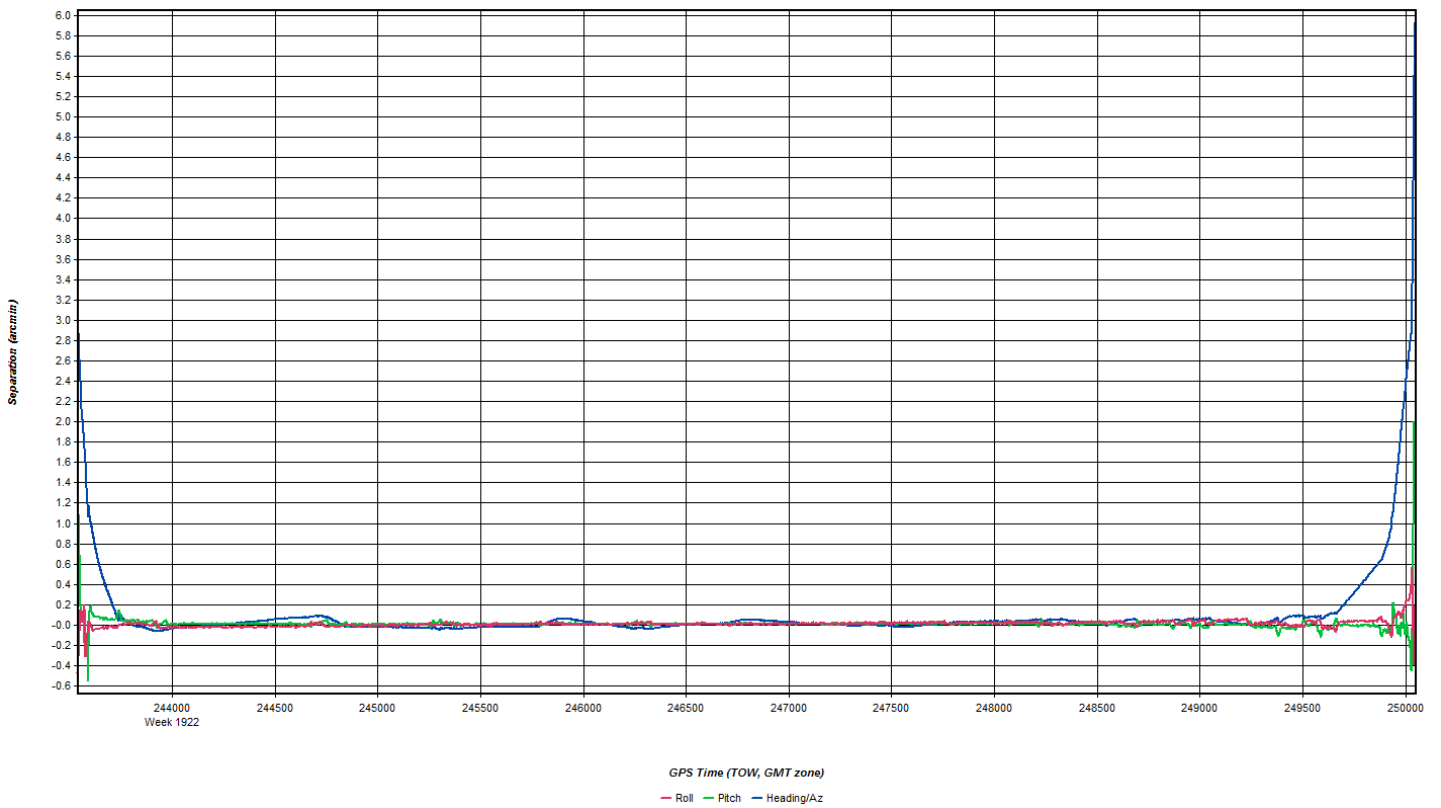

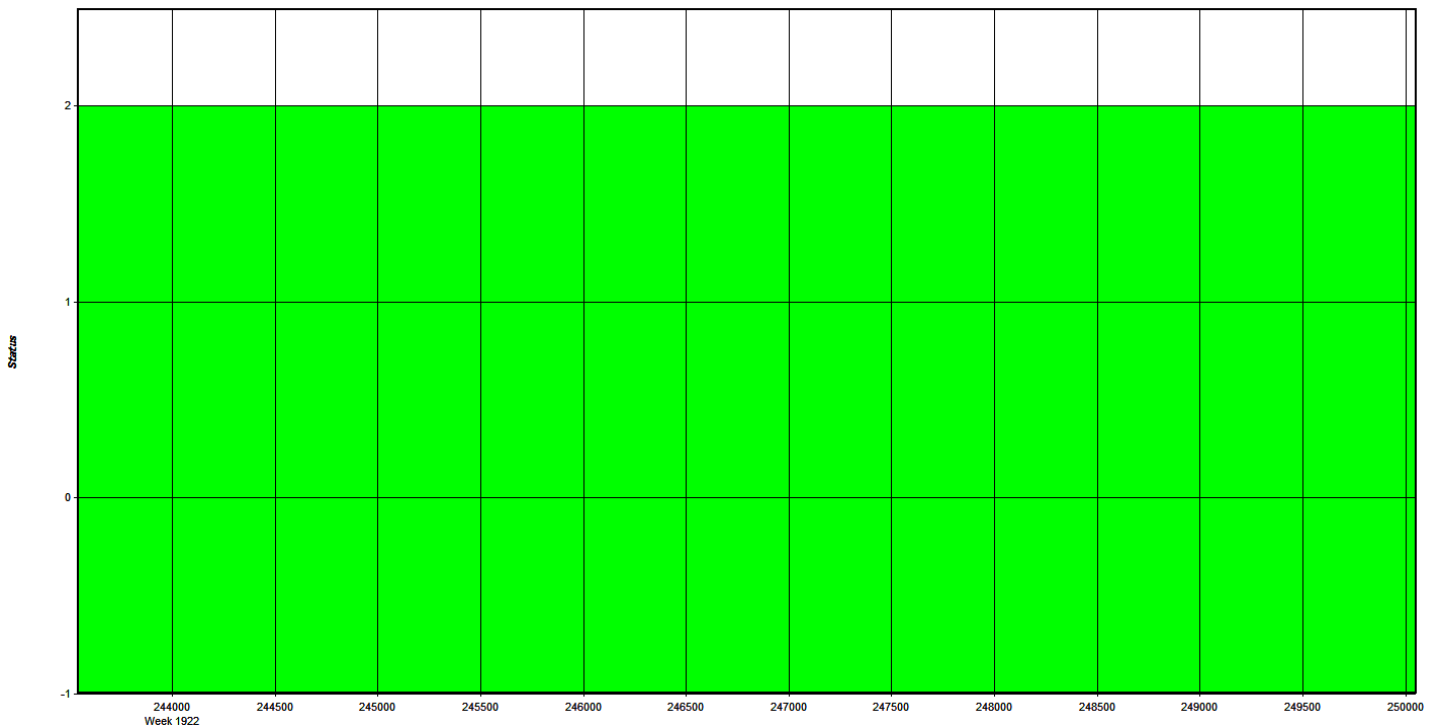

GPS Time (TOW, GMT zone)
 - Float - Forward Fixed - Reverse Fixed - Fixed (2 or more)

Coordinate/Antenna Settings

Master Remote

Base Station
 2: VCAP Name: VCAP Disabled
 File: E:\Proc\29178_VT_CT_River_Basin\20161108_190958\vcap31

Coordinates
 Latitude: North 44 15 43.10641 Compute from PPP
 Longitude: West 72 34 56.55478 Enter Grid Values
 Ellipsoidal height: 160.539 m Enter MSL Height
 Datum: WGS84 Datum Options
 Select From Favorites Add To Favorites Use Average Position

Antenna Height
 From station file: TRM55971.00, NONE View STA File
 Antenna profile: TRM55971.00 Info
 Measured height: 0.000 m
 ARP to L1 offset: 0.067 m
 Applied height: 0.067 m
 Measured to:
 ARP
 L1 Phase Centre
 Compute From Slant

OK Cancel

Coordinate/Antenna Settings
? X

Master
Remote

Base Station

1: VTC1

Name: VTC1

Disabled

File: E:\Proc\29178_VT_CT_River_Basin\20161108_190958\vtc1313

Coordinates

Latitude: North

43

56

21.21809

Compute from PPP

Longitude: West

72

36

12.56537

Enter Grid Values

Ellipsoidal height: 405.144

m

Enter MSL Height

Datum: WGS84

Datum Options

Select From Favorites

Add To Favorites

Use Average Position

Antenna Height

From station file: TRM55971.00, NONE

View STA File

Antenna profile: TRM55971.00

Info

Measured height: 0.000

m

Measured to

ARP to L1 offset: 0.067

m

ARP

Applied height: 0.067

m

L1 Phase Centre

Compute From Slant

OK

Cancel

Flight Log

11-8-16 B Mission 29178

Quantum Spatial
Airborne LIDAR Data Collection Log Sheet :: Quantum Spatial, Inc
(email log daily to flight_log_distribution_list@quantumspatial.com)

Date: 11-8-16 B
UIC: A B C D E pg 2 of 2

Project: CRiver in VT
Flights Mgmt File: 20161108-190958

Aircraft: N226E Begin Hobbs: 89518 End Hobbs: 89540 Total: 2.2 Pilot: TRadtko Co-Pilot: JUMAN Tech: JUMAN

Dep Apt: KLEB Dep Time (Lcl): 1922 (Z): +5 Arr Apt: Arr Time (Local): 1638 (Z): +5 Tot Time Aloft: 2.3

CORS: (Y)N Sta 1: VTCL Flyovers: (Y)N If Y, times: Sta1) 1935/212.2 Sta2)

GPS Unit: Y/N Sta 1: Sta 2: Flyovers: Y/N If Y, times: Sta1) Sta2)

Gd Temp beg: +12 °C End: 0 °C OAT beg: +6 °C End: +4 °C Altimeter begin: 3005 end: 2998

Type	Serial #	Alt AMSL	Avg Terr Ht	Max Gdspd	Avg Pt Spading	Power	PPSH	Mag Job	Image Name
LIDAR	A157	7161				100%		95	017
	40	53 Hz						78	
								17	

Line #	Hdg	Start (UTC)	End (UTC)	Gd Spd	POF/s	GPS Altitude	Crab	Turb (0-1)	Notes
2006	197	1947	1957	144	1.1/18	7476		0	LEB → VTCL → Fig 8's @ 1941
2005	17	2001	2007	161	1.3/16	7464		0	
2004	197	2010	2016	142	1.3/16	7400		0	
2003	17	2019	2023	166	1.3/17	7526		0	
2002	197	2026	2031	163	1.3/17	7524		0	
2001	17	2034	2038	158	1.3/17	7522		0	
2099	107	2016	2048	160	1.3/17	7469		0	
2064	347	2054	2056	164	1.2/17	8400		0	
2065	167	2100	2101	145	1.2/17	8327		0	
2066	347	2105	2107	146	1.2/17	8287		0	
Xtie	772	2111	2113	180	1.1/18	8300		0	Unplanned X tie Fig 8's 2114 - VTCL 2122 Site → KLEB
		2122	2138						

ONLINE = 1.4
MOB = 0.8
Hobbs = 2.2

Daily total Hobbs = 5.4
online mob = 3.9
mob entire = 1.5

x tie planned

FLIGHT LINE NOTES - visibility, clouds, smoke, partial, etc.

Total Proj Lines: Lines Flow: Lines Remain: Online Time: 1.4 Mob Time: 0.8 Notes:

Nov 8, 2016-B (N73TM, SN7178)

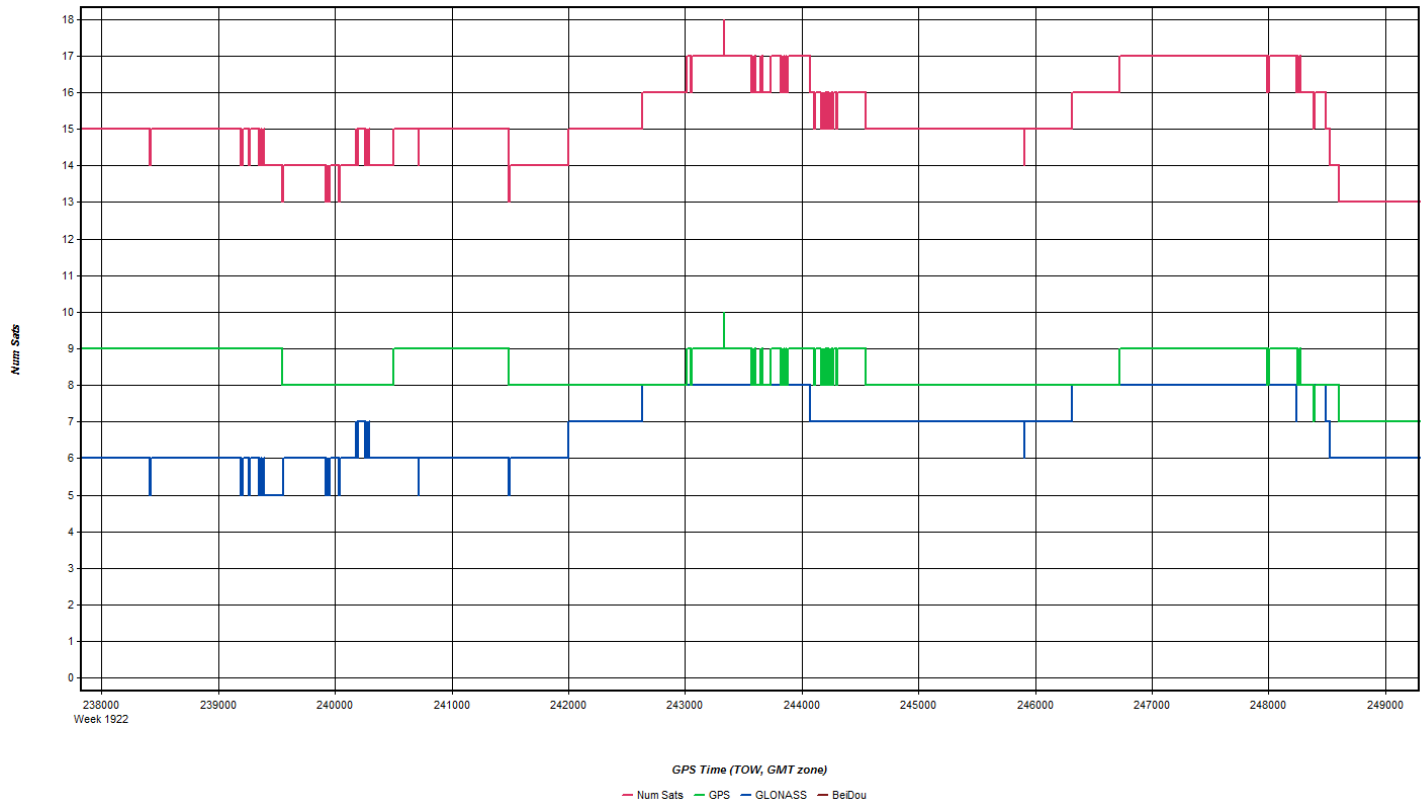
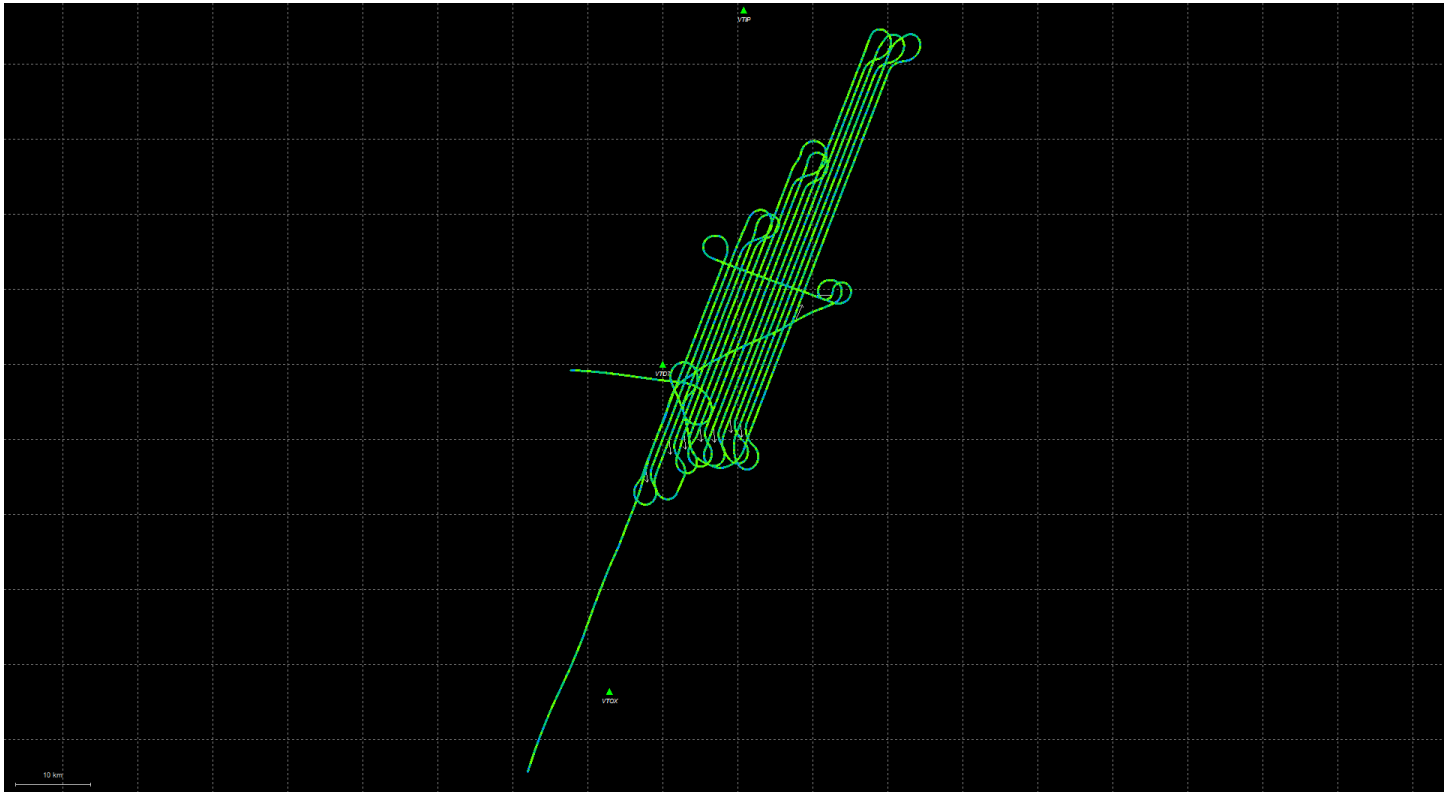

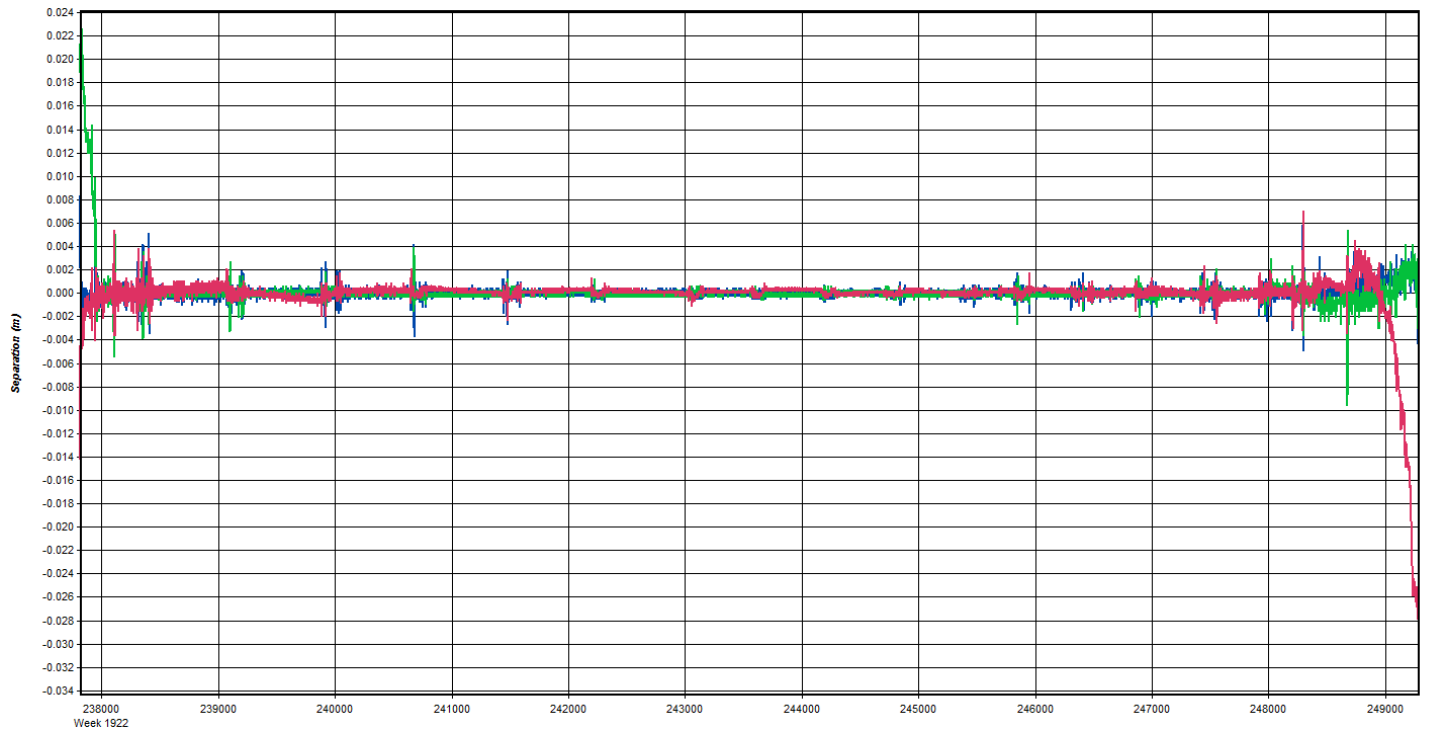

GPS Time (TOW, GMT zone)

— East — North — Up

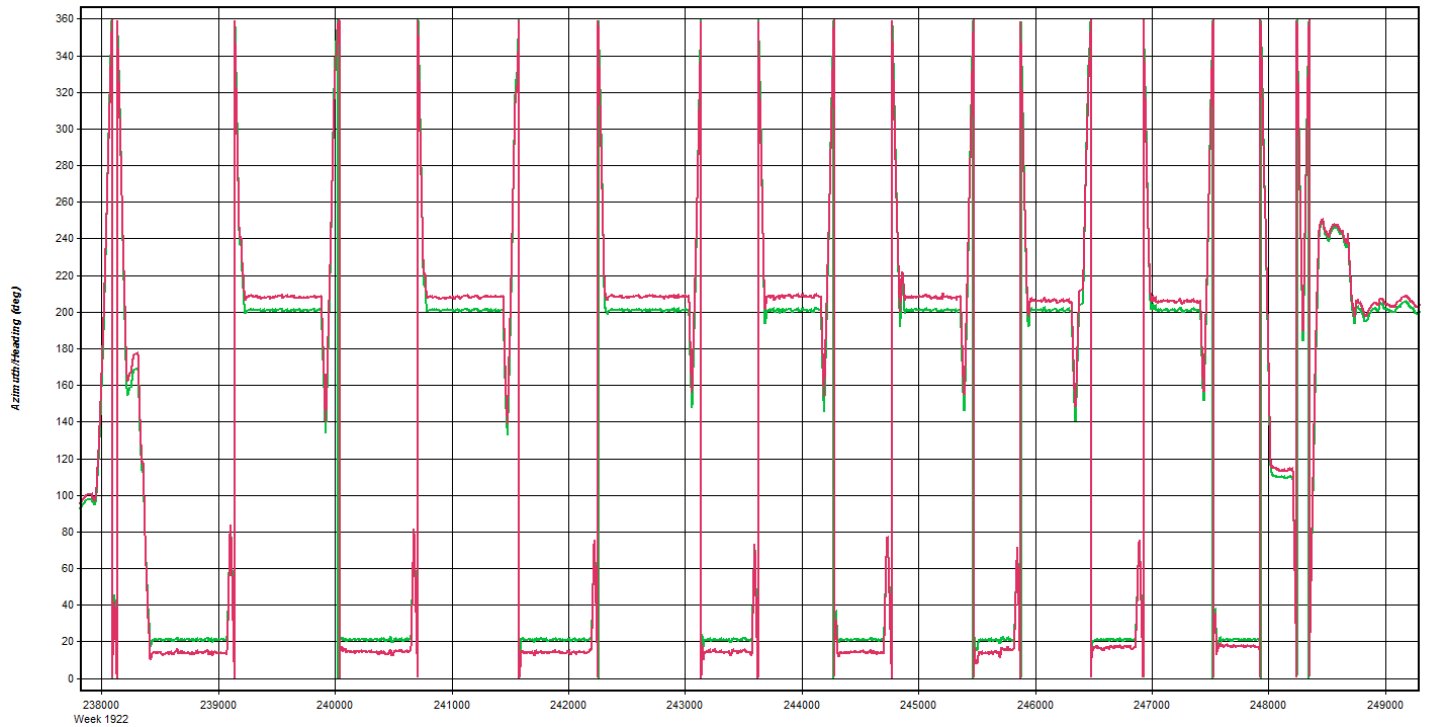

GPS Time (TOW, GMT zone)

— Heading/Azimuth — GPS-COG

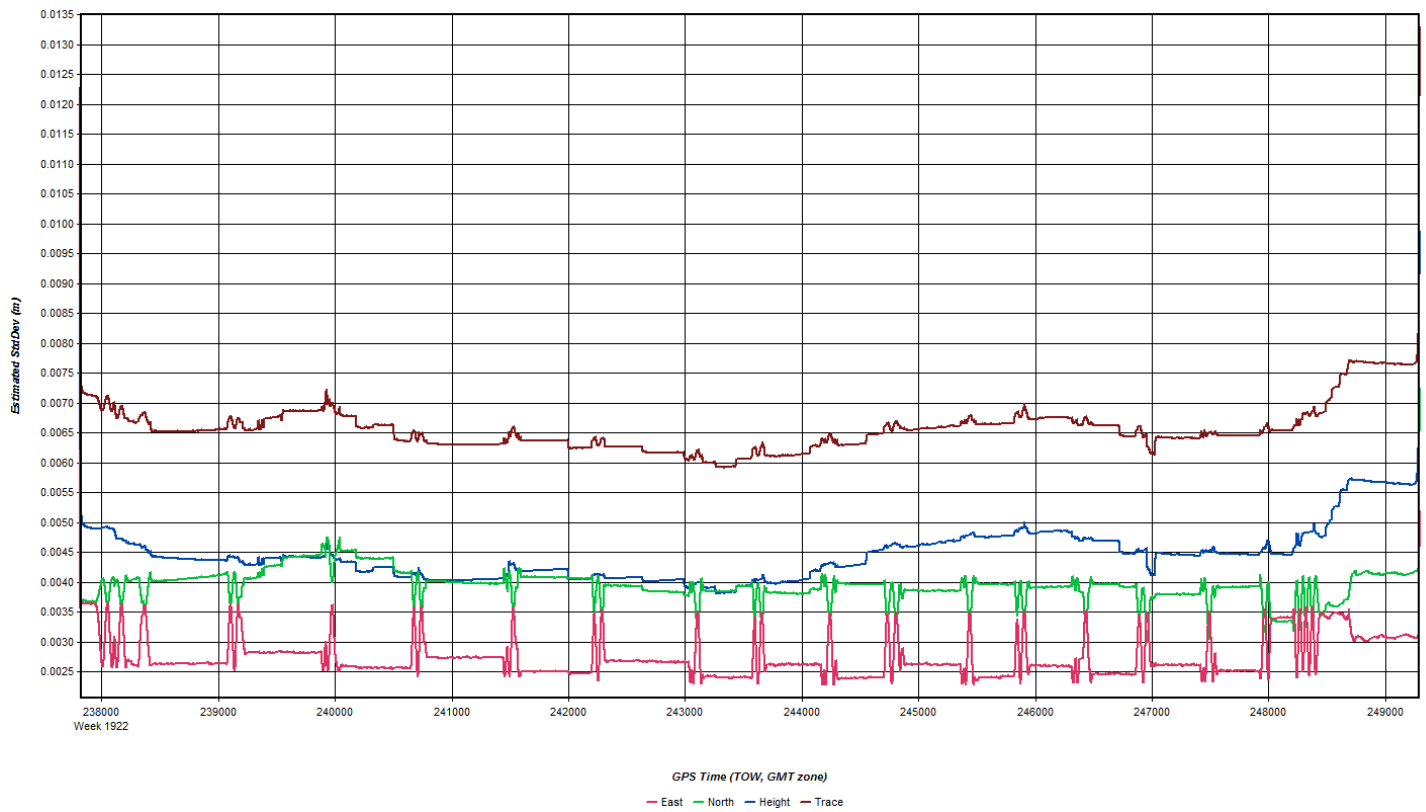
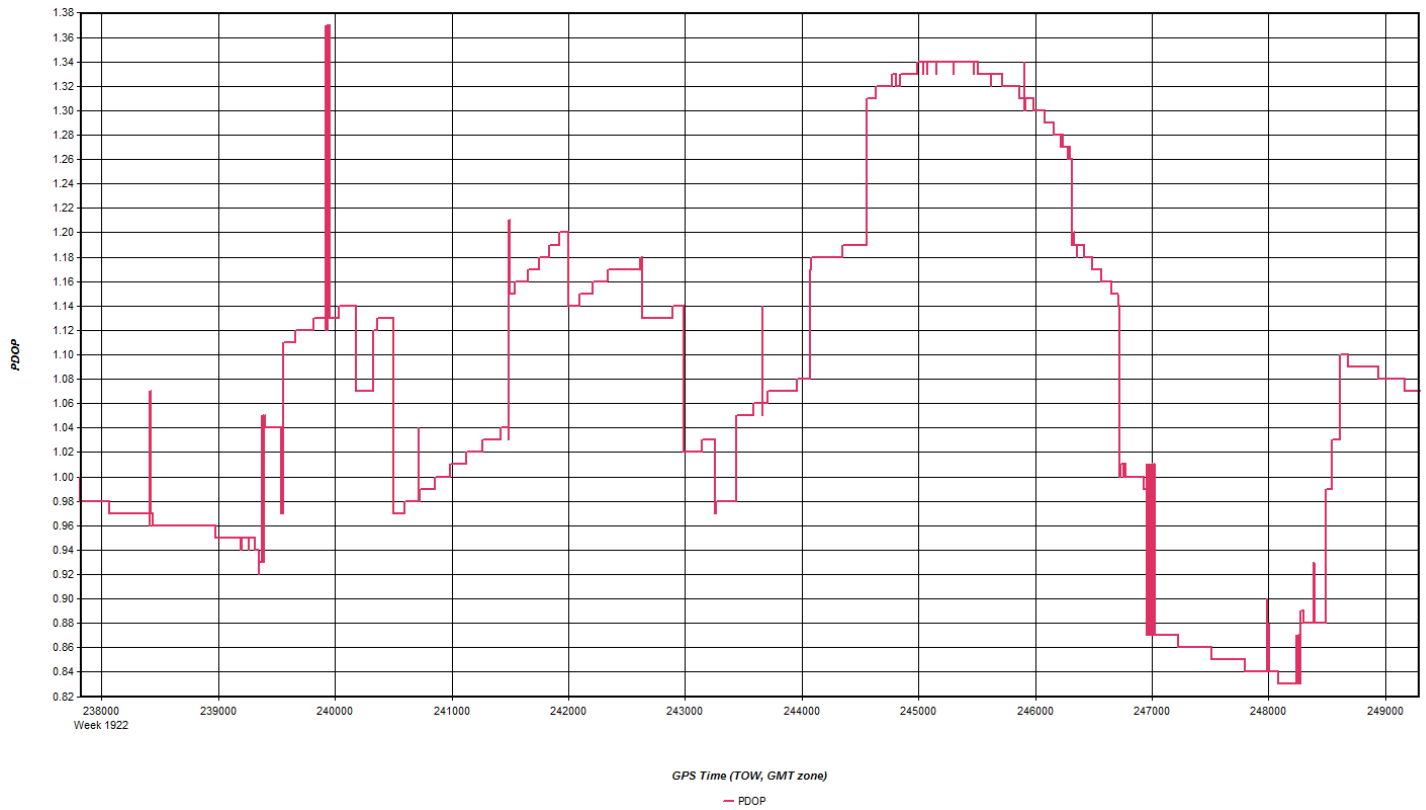

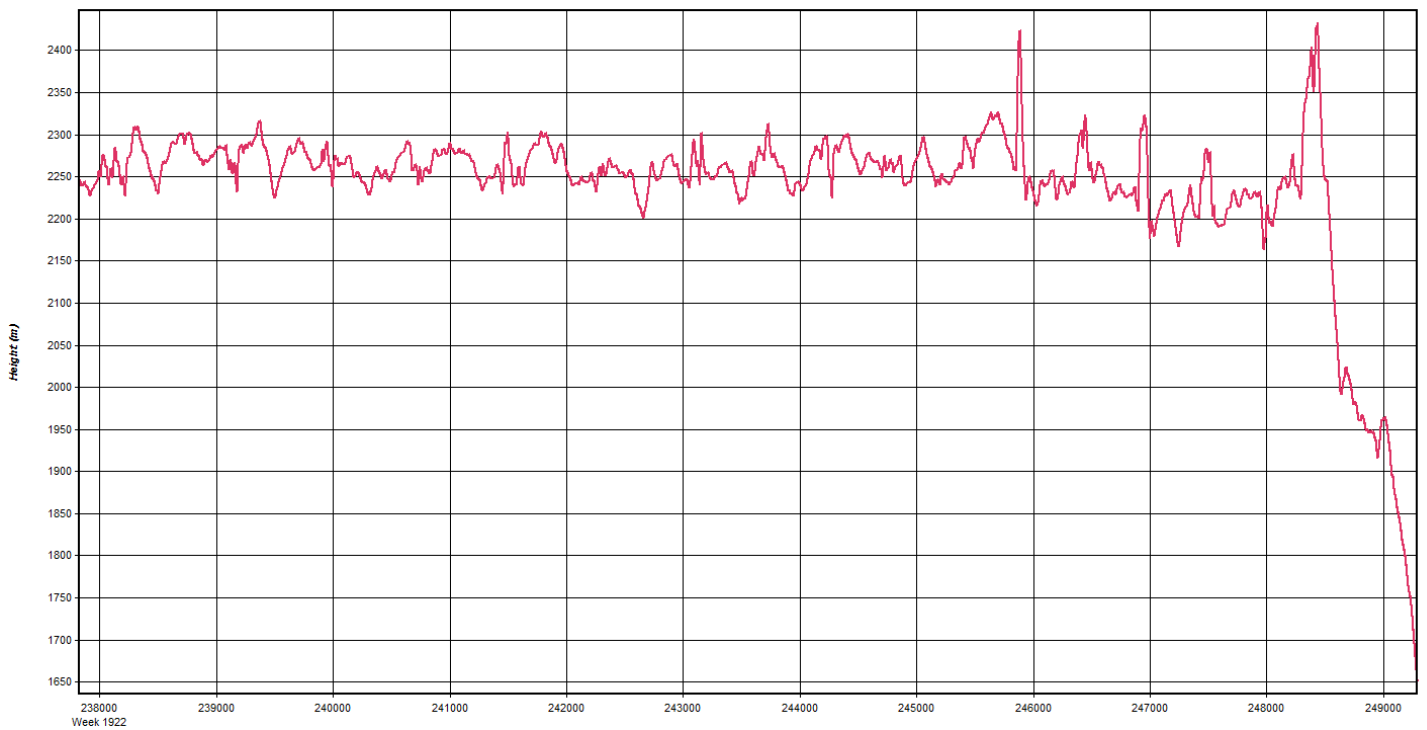
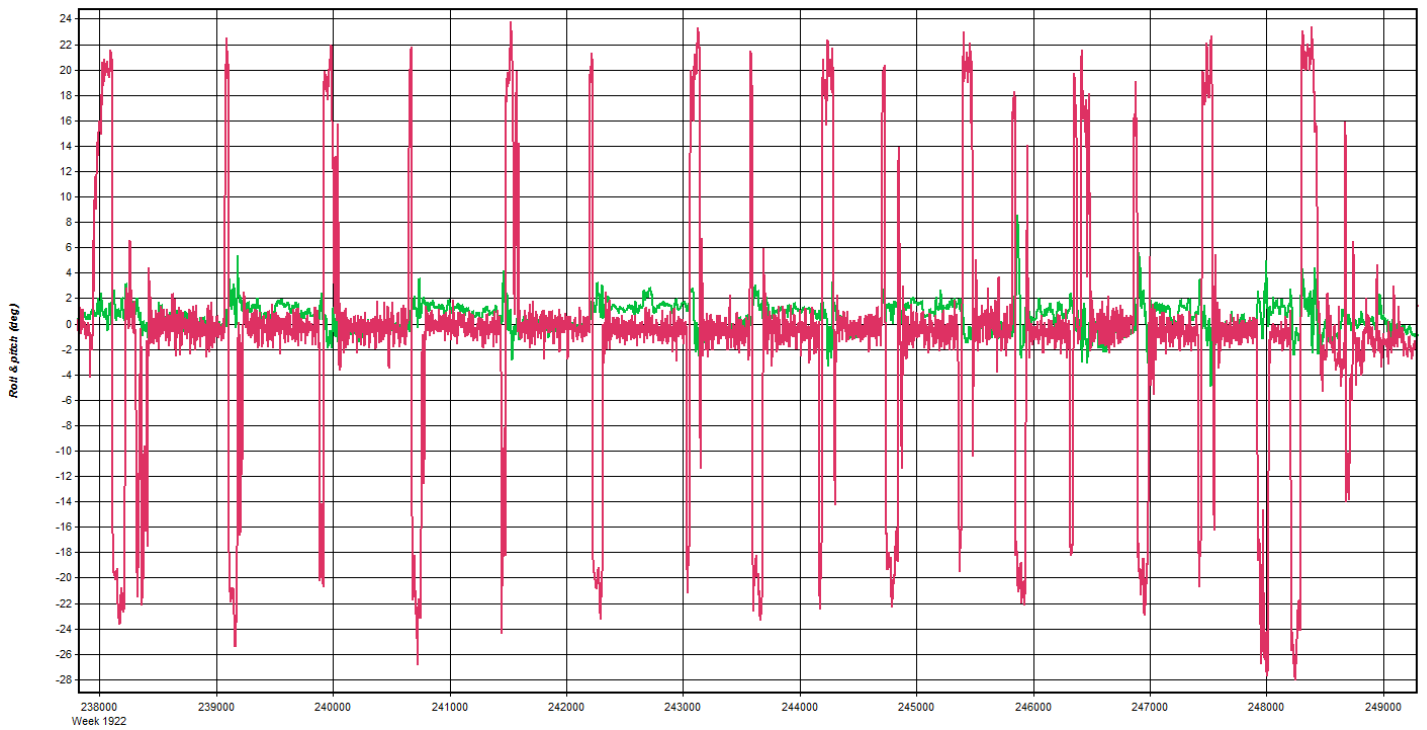

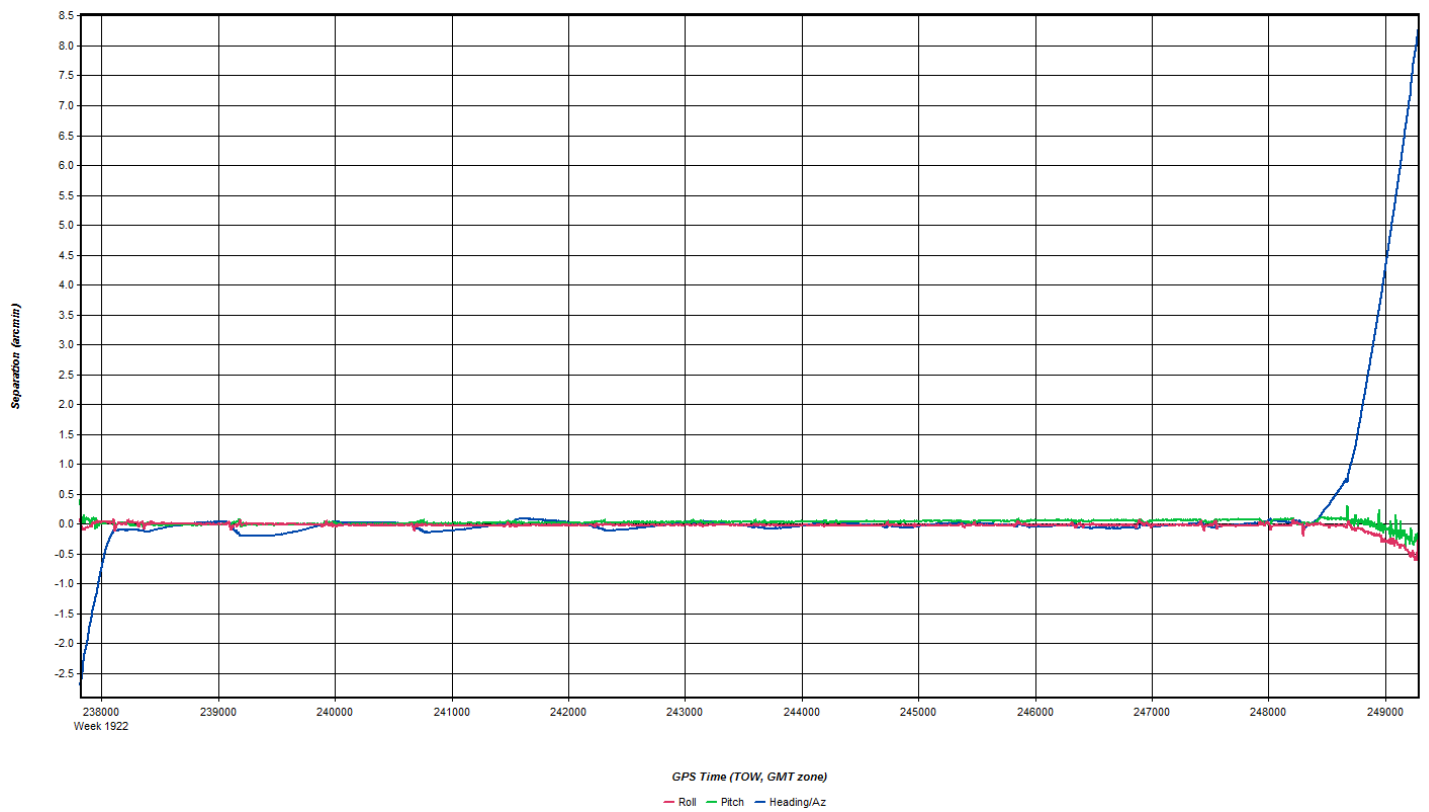

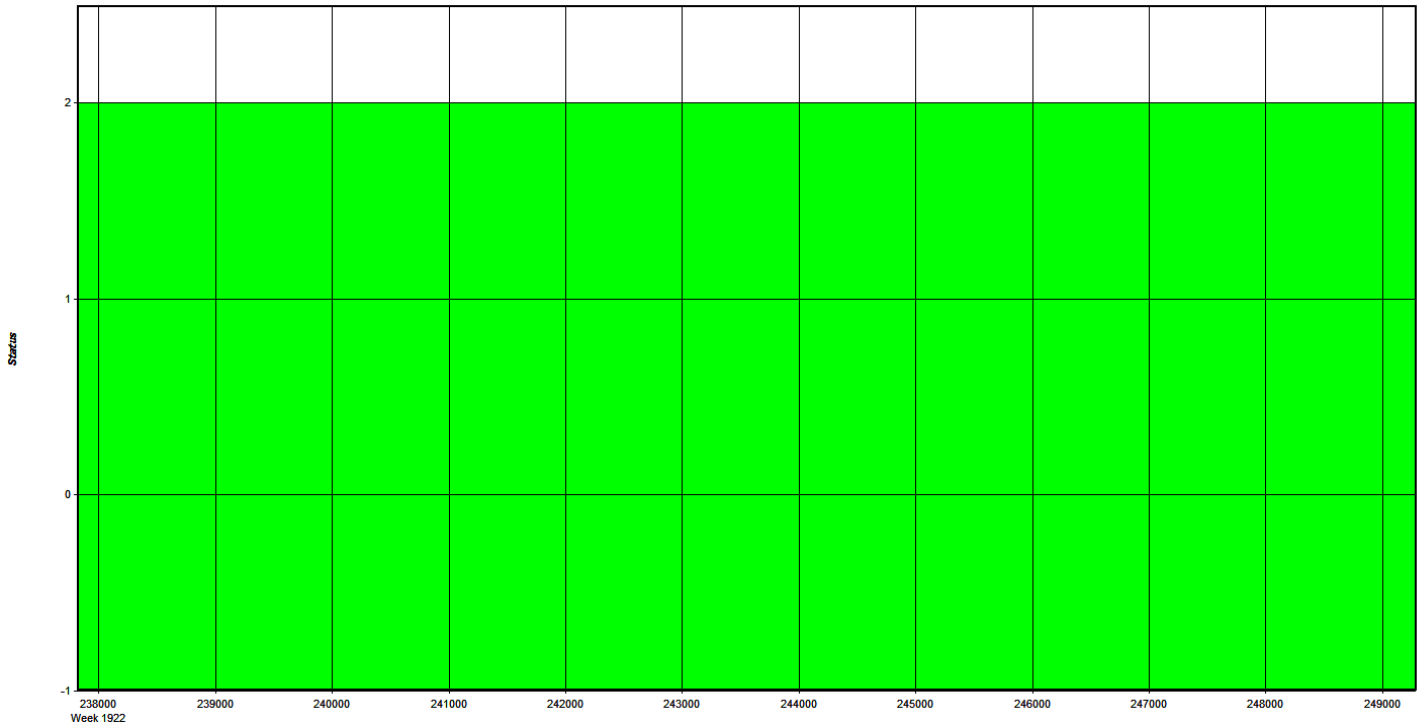

GPS Time (TOW, GMT zone)
 - Float - Forward Fixed - Reverse Fixed - Fixed (2 or more)

Coordinate/Antenna Settings

Master Remote

Base Station
 1: VTD7 Name: VTD7 Disabled
 File: E:\Proc\29178_VT_CT_River_Basin\20161108_AB_29178_ALS7

Coordinates
 Latitude: North 44 23 52.31066 Compute from PPP
 Longitude: West 72 01 32.39267 Enter Grid Values
 Ellipsoidal height: 166.528 m Enter MSL Height
 Datum: WGS84 Datum Options
 Select From Favorites Add To Favorites Use Average Position

Antenna Height
 From station file: TRM55971.00, NONE View STA File
 Antenna profile: TRM55971.00 Info
 Measured height: 0.000 m
 ARP to L1 offset: 0.067 m
 Applied height: 0.067 m
 Measured to:
 ARP
 L1 Phase Centre
 Compute From Slant

OK Cancel

Coordinate/Antenna Settings
? X

Master
Remote

Base Station

2: VTIP Name: VTIP Disabled

File: E:\Proc\29178_VT_CT_River_Basin\20161108_AB_29178_ALS7

Coordinates

Latitude: North 44 49 12.18043 Compute from PPP

Longitude: West 71 53 25.83872 Enter Grid Values

Ellipsoidal height: 341.732 m Enter MSL Height

Datum: WGS84 Datum Options

Select From Favorites
Add To Favorites
Use Average Position

Antenna Height

From station file: TRM55971.00, NONE View STA File

Antenna profile: TRM55971.00 Info

Measured height: 0.000 m

ARP to L1 offset: 0.067 m

Applied height: 0.067 m

Measured to

ARP

L1 Phase Centre

Compute From Slant

OK
Cancel

Coordinate/Antenna Settings
? X

Master
Remote

Base Station

3: VTOX Name: VTOX Disabled

File: E:\Proc\29178_VT_CT_River_Basin\20161108_AB_29178_ALS7

Coordinates

Latitude: North 44 00 28.16564 Compute from PPP

Longitude: West 72 06 51.60957 Enter Grid Values

Ellipsoidal height: 126.405 m Enter MSL Height

Datum: WGS84 Datum Options

Select From Favorites
Add To Favorites
Use Average Position

Antenna Height

From station file: TRM55971.00, NONE View STA File

Antenna profile: TRM55971.00 Info

Measured height: 0.000 m

ARP to L1 offset: 0.067 m

Applied height: 0.067 m

Measured to

ARP

L1 Phase Centre

Compute From Slant

OK
Cancel

Flight Log

Project: USGS CT RIVER BASIN

Project #: 29178

Flight Mgmt File: 29178_USGS_WINDSOR-STA1-1805-2104-16109-17370.5

Altcraft: BTU

Begin Hobbs: 64747

End Hobbs: 64783

Total: 36

Pilot: BILLYNORRIS

Co-Pilot: MURPHY

Dep Apt: BTU

Dep Time (Lcl): 1248 [Z]: 1748

Arr Apt: LEB

Arr Time (Local): 1620 [Z]: 2120

Tot Time Aloft: 3:30

CORS: N

Sta 1: VTD7

Sta 2:

GPS Unit: Y / N

Sta 1:

Sta 2:

Flyovers: N

IF Y, times: Sta 1: 1805 2104

Sta 2:

IF Y, times: Sta 1:

IF Y, times: Sta 2:

Date: 11-8-16

Lift: A @ C D E

pg. 1 of 1

Line #	Hdg	Start (UTC)	End (UTC)	Gd Spd	POD/Freq	GPS Altitude	Crab	Turb (0..+)	Alt				Pulse Rate	Pulse In Air	Pulse Power	Max Gdspd	Avg Ft Spacing	PPSM	Store Name
									AGL	MSL	AMSLL	End							
3045	021	1814	1824	161		14/16	7370	1	0	155	2	20.4 KHZ	100%	155	88	43	7170	5583	
3044	201	1827	1837	150		12/16	7500	2	0	155	3	20.4 KHZ	100%	155	88	43	7170	5583	
3043	021	1841	1850	165		11/17	7490	3	0	155	4	20.4 KHZ	100%	155	88	43	7170	5583	
3042	201	1853	1903	151		12/16	7400	4	0	155	5	20.4 KHZ	100%	155	88	43	7170	5583	
3041	021	1906	1916	163		11/16	7370	4	0	155	6	20.4 KHZ	100%	155	88	43	7170	5583	
3040	201	1919	1930	148		10/19	7410	6	0	155	7	20.4 KHZ	100%	155	88	43	7170	5583	
3039	021	1932	1939	168		11/18	7390	6	0	155	8	20.4 KHZ	100%	155	88	43	7170	5583	
3038	201	1942	1949	154		11/18	7450	13	0	155	9	20.4 KHZ	100%	155	88	43	7170	5583	
3037	021	1951	1958	164		12/17	7490	8	0	155	10	20.4 KHZ	100%	155	88	43	7170	5583	
3036	201	2001	2008	160		12/17	7350	16	0	155	11	20.4 KHZ	100%	155	88	43	7170	5583	
3035	021	2011	2016	163		16/15	7520	0	0	155	12	20.4 KHZ	100%	155	88	43	7170	5583	
3034	201	2019	2024	161		13/17	7320	0	0	155	13	20.4 KHZ	100%	155	88	43	7170	5583	
3033	021	2028	2033	167		13/17	7386	0	0	155	14	20.4 KHZ	100%	155	88	43	7170	5583	
3032	201	2037	2043	162		13/17	7220	0	0	155	15	20.4 KHZ	100%	155	88	43	7170	5583	
3031	021	2045	2051	166		12/17	7190	0	0	155	16	20.4 KHZ	100%	155	88	43	7170	5583	
TIME	110	2053	2056	179		12/17	7220	0	0	155	17	20.4 KHZ	100%	155	88	43	7170	5583	

Total Proj Lines: 17

Lines Flown: 17

Lines Remain: 0

Online Time: 2:75

Mob Time: 0:75

Notes:

Nov 10, 2016-A (N22GE, SN7161)

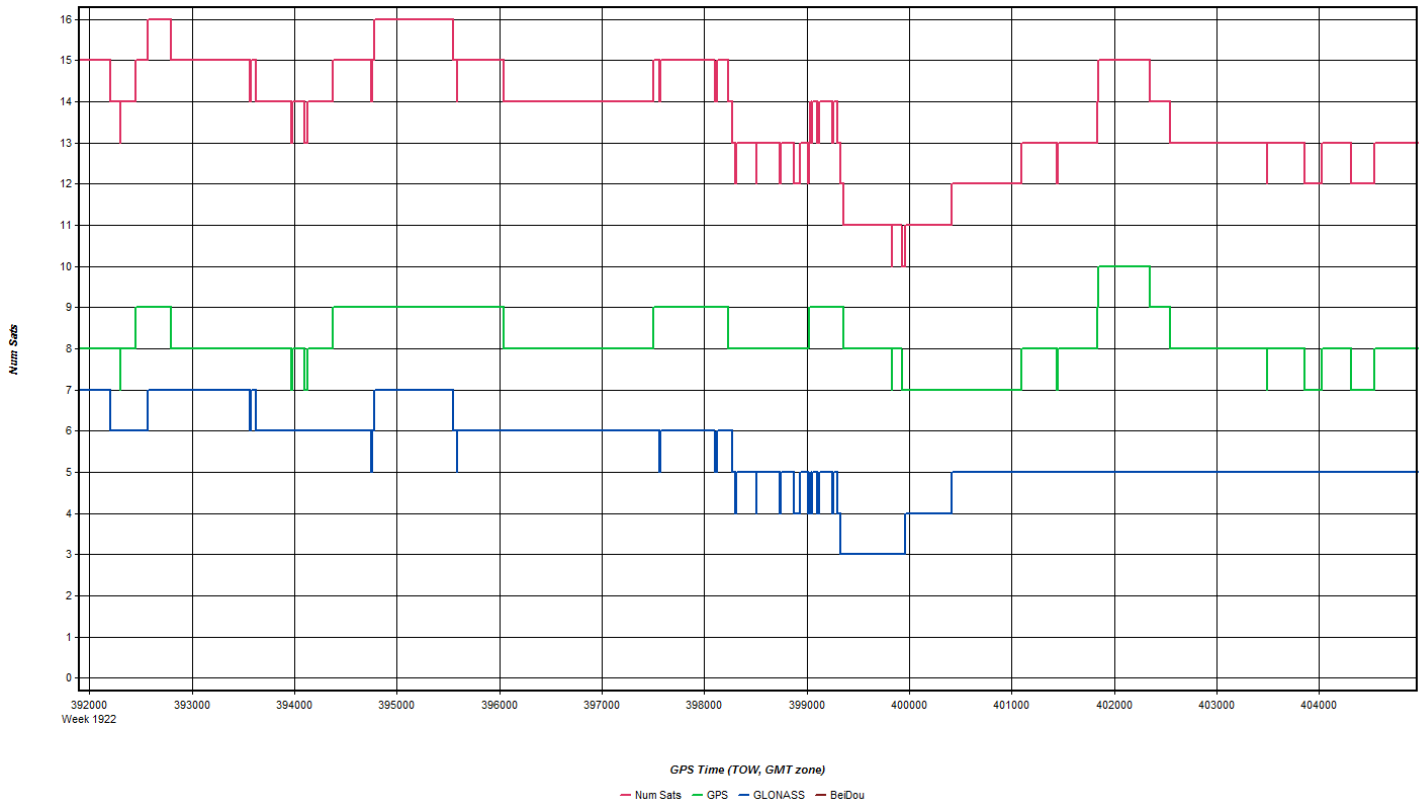
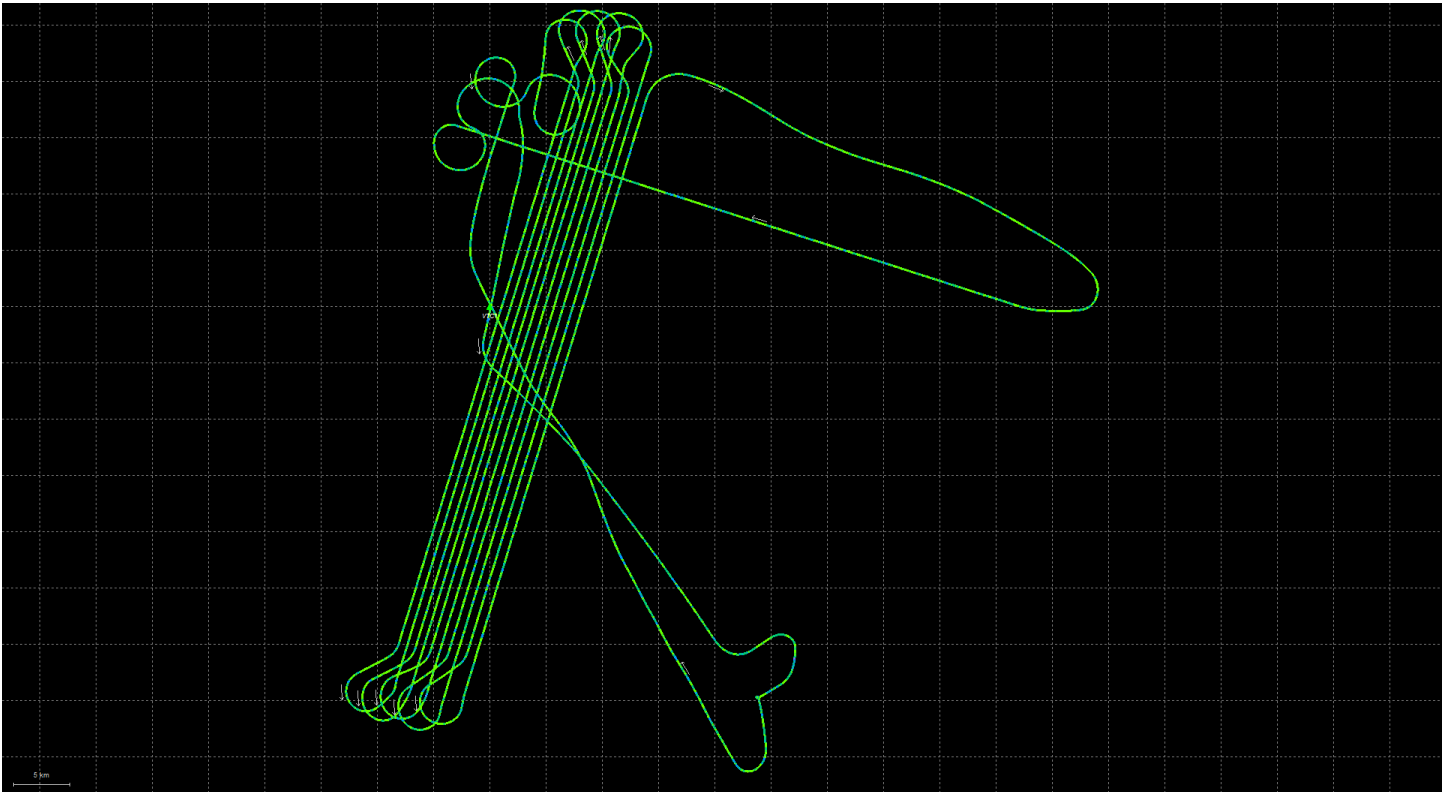

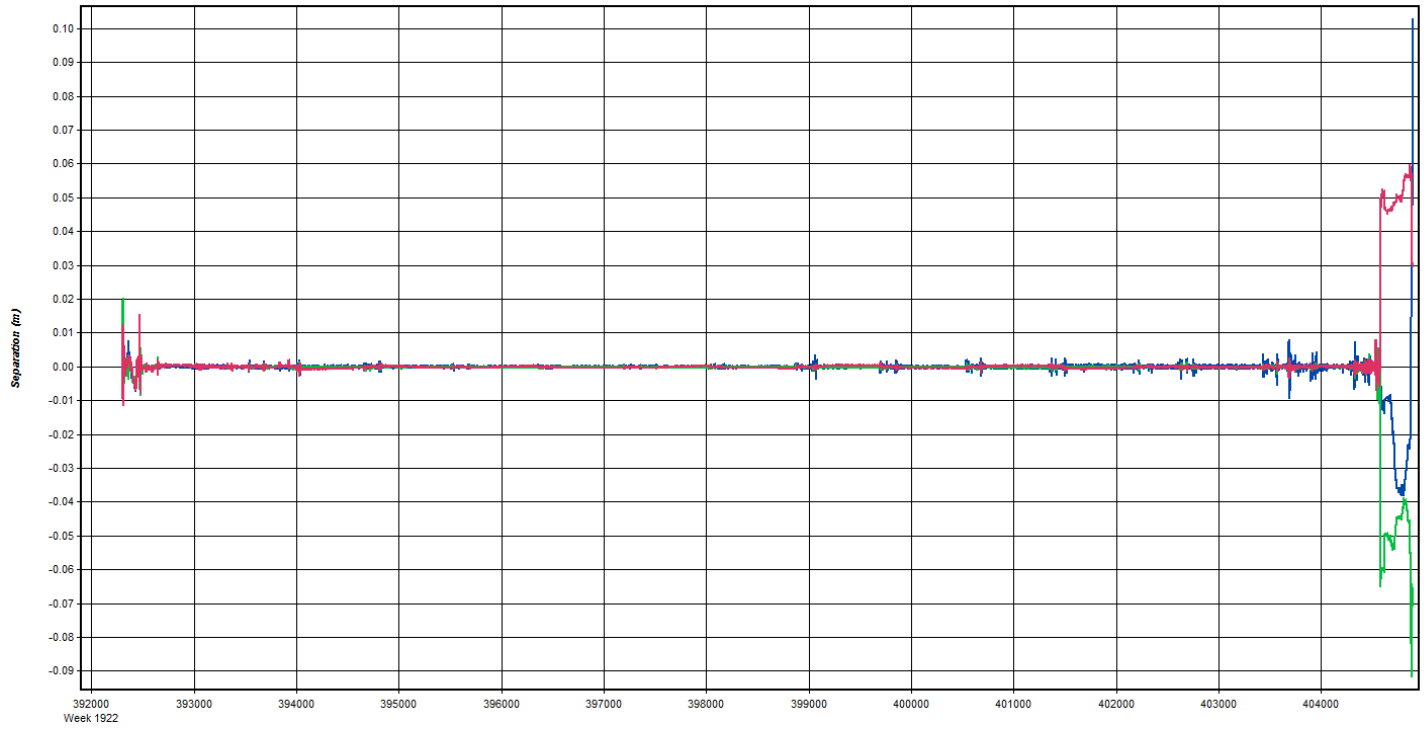

GPS Time (TOW, GMT zone)
— East — North — Up

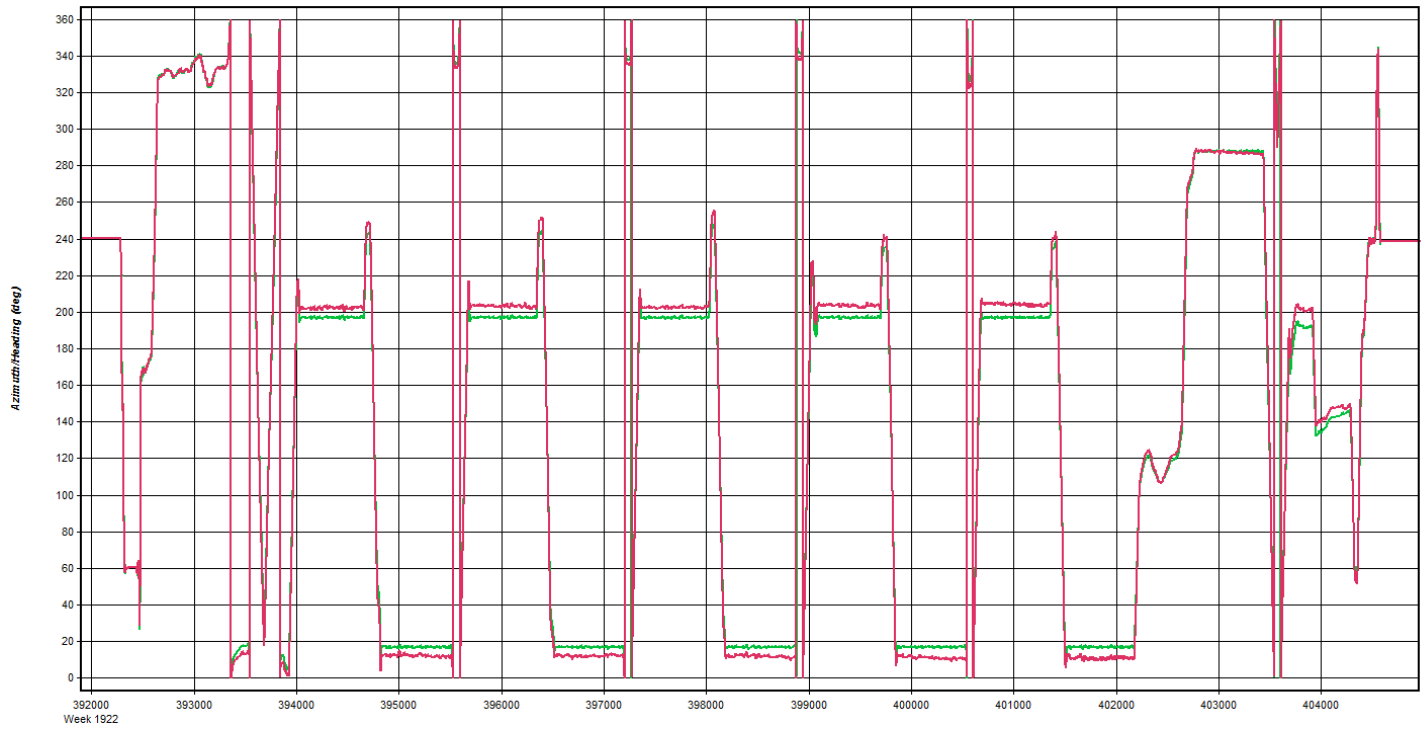

GPS Time (TOW, GMT zone)
— Heading/Azimuth — GPS-COG

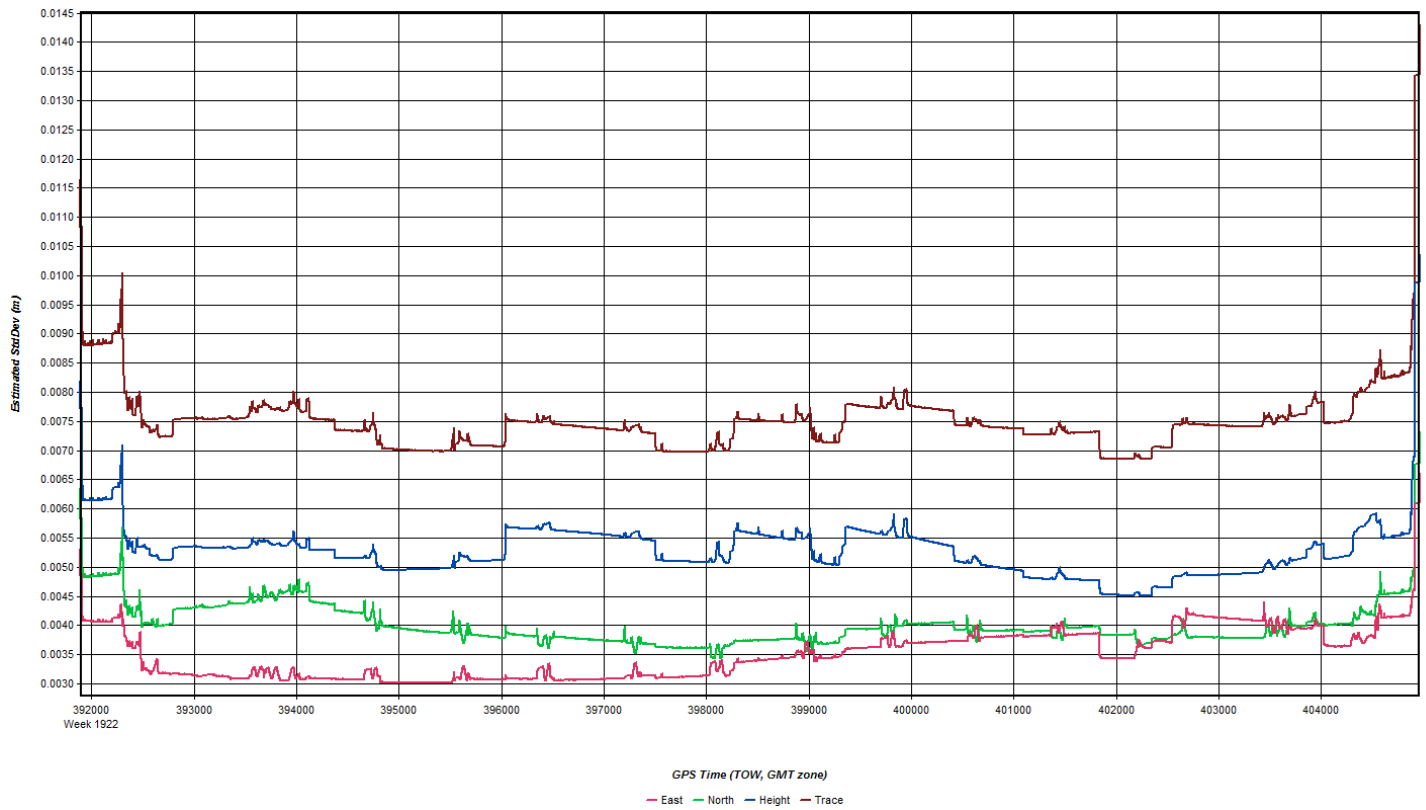
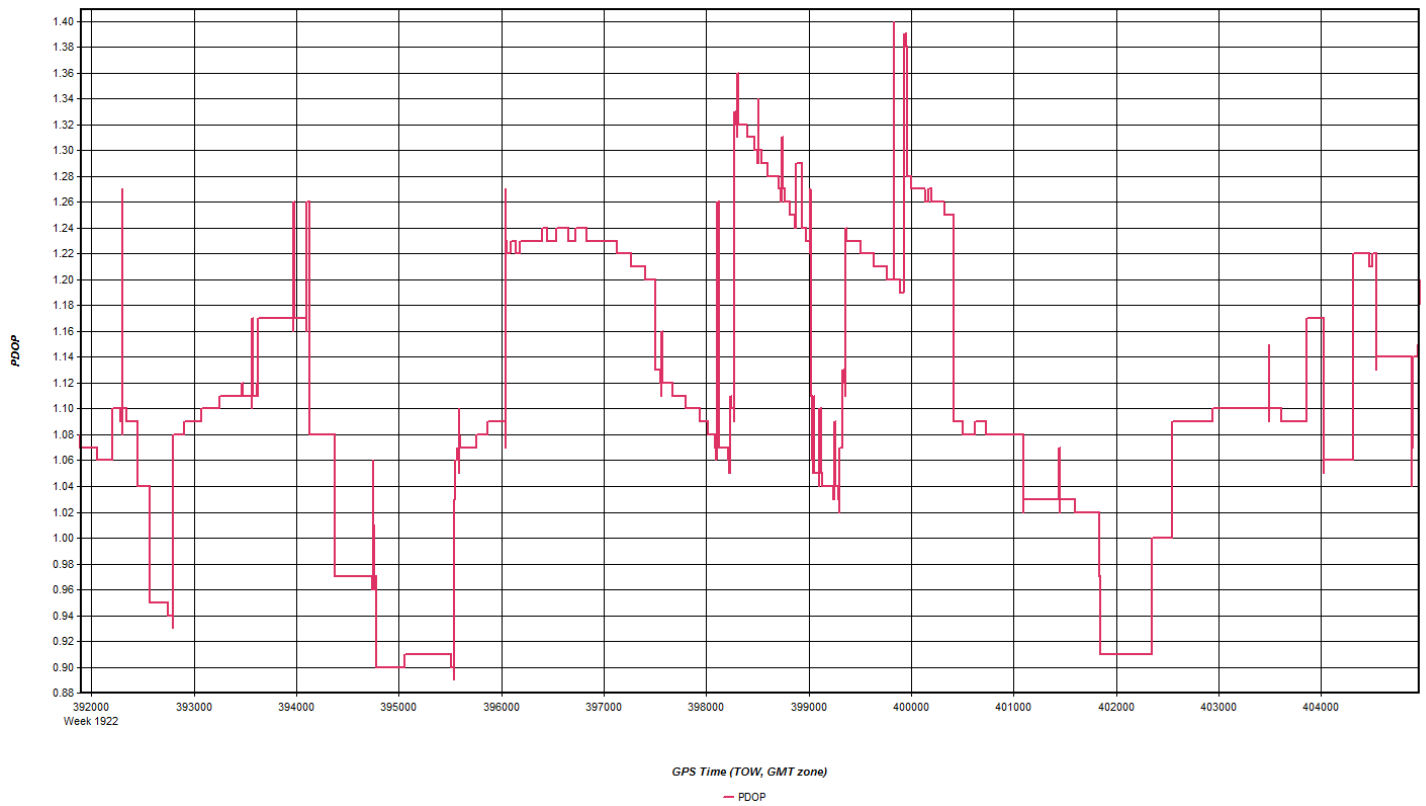

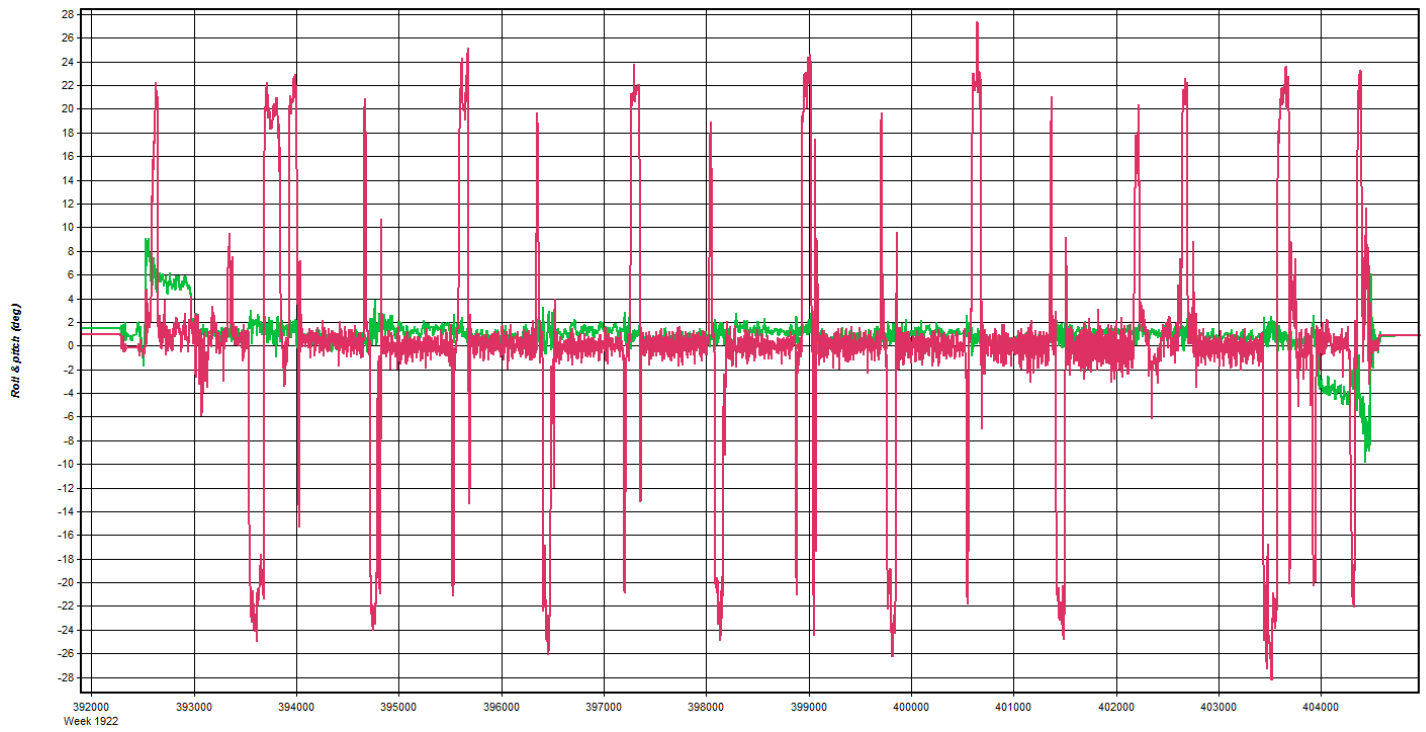

GPS Time (TOW, GMT zone)
— Roll — Pitch

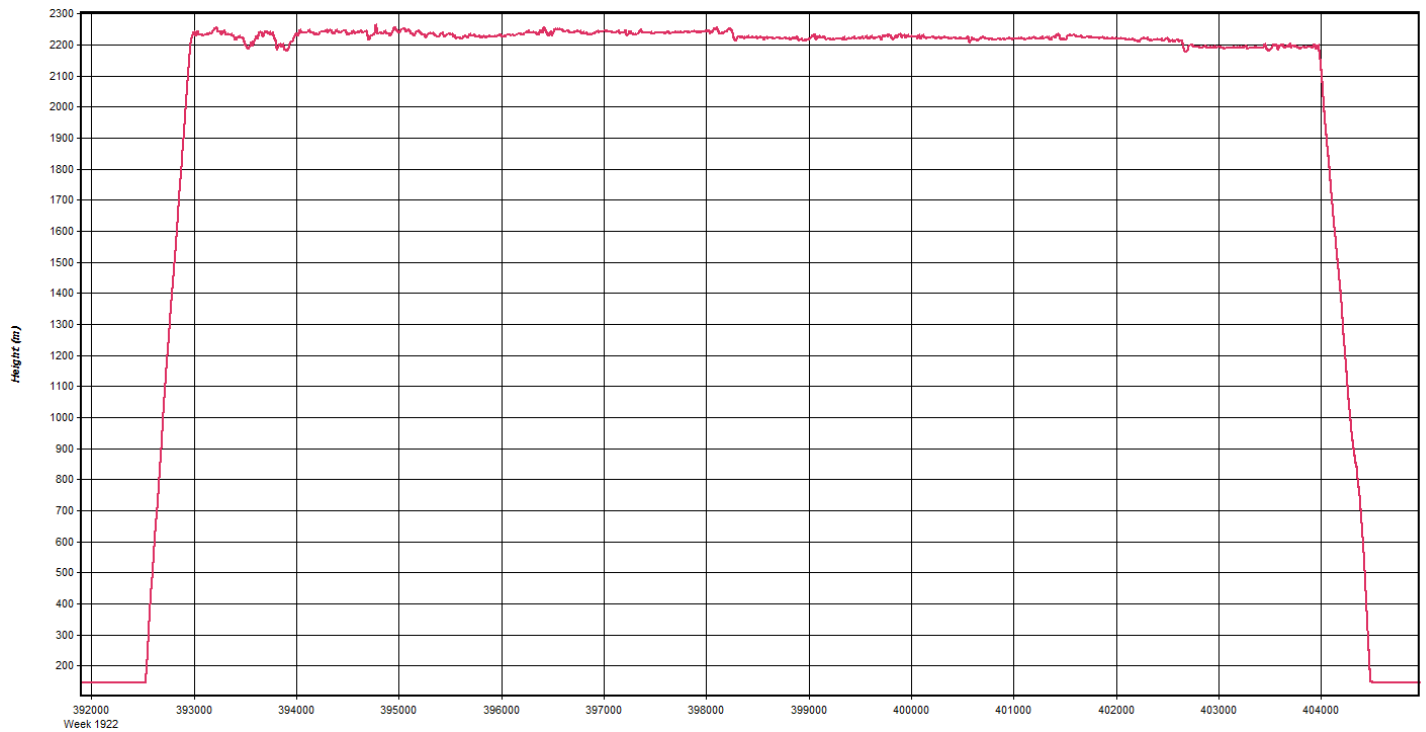

GPS Time (TOW, GMT zone)
— Height

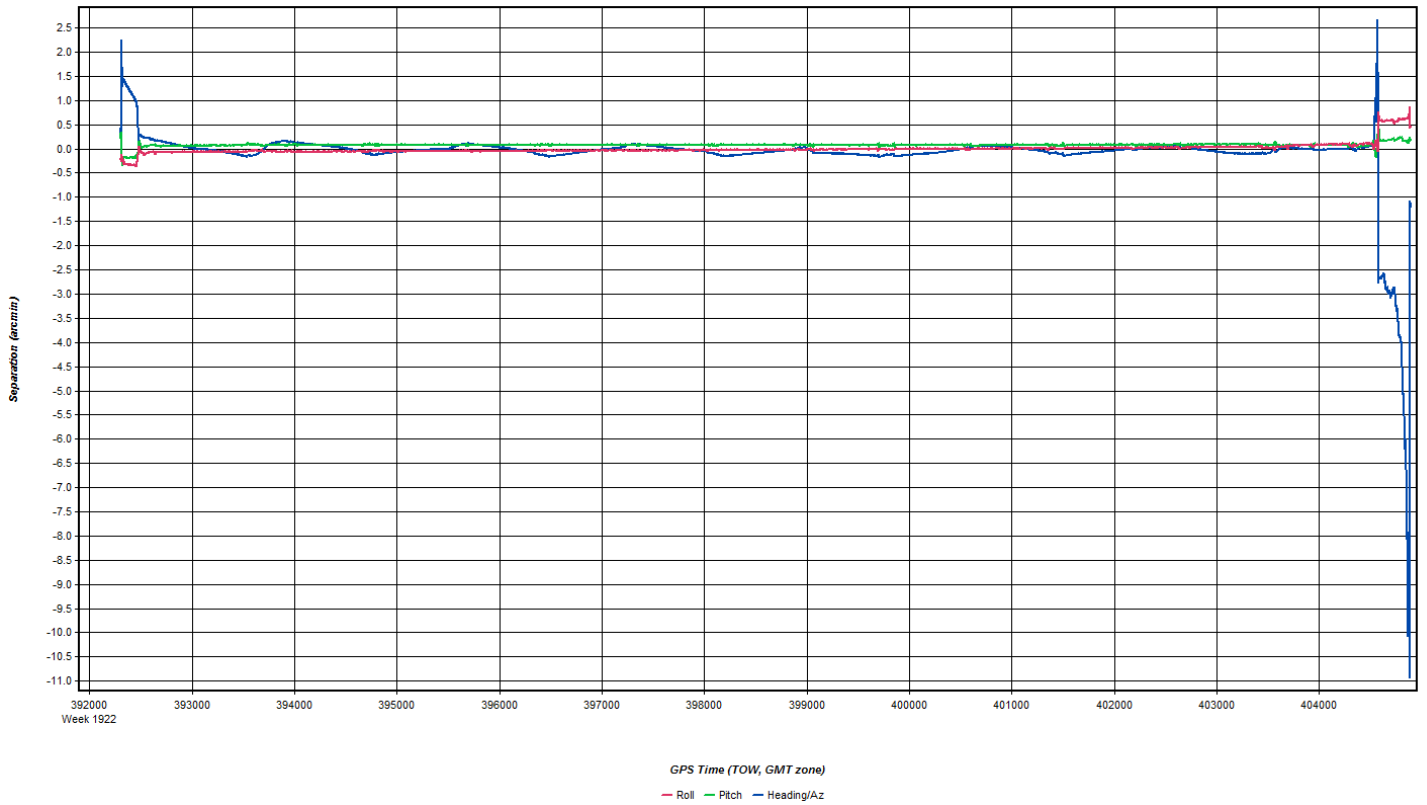
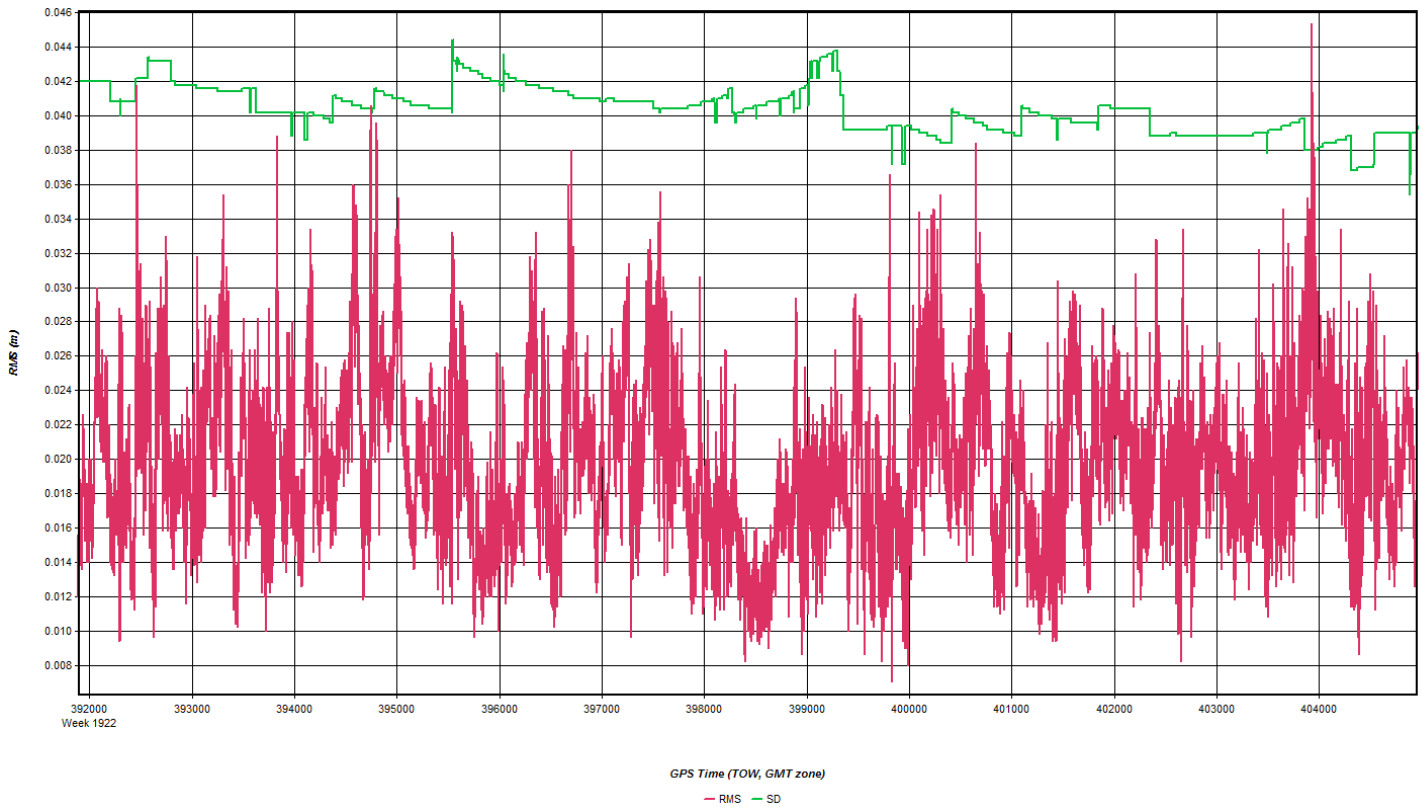

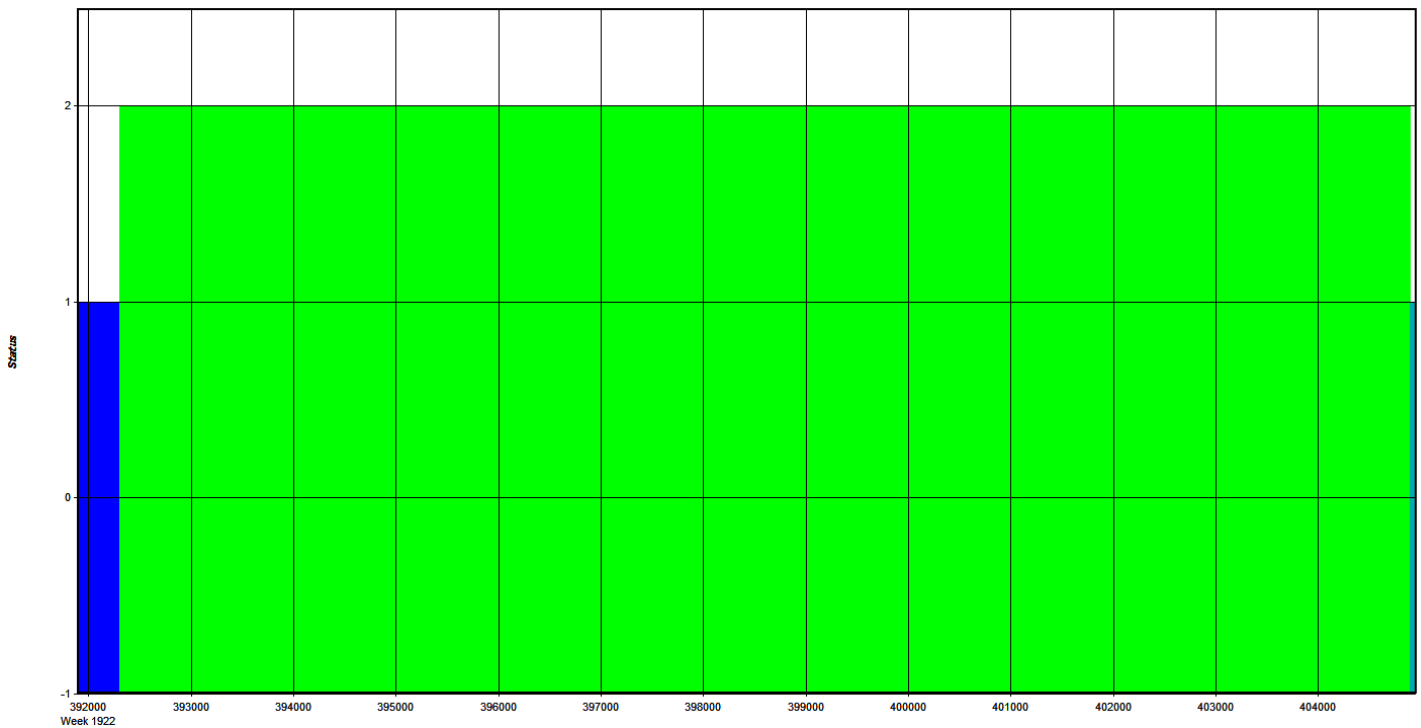

GPS Time (TOW, GMT zone)
 - Float - Forward Fixed - Reverse Fixed - Fixed (2 or more)

Coordinate/Antenna Settings

Master Remote

Base Station
 1: VTC1 Name: VTC1 Disabled
 File: E:\Proc\29178_CT_River\29178_ALS70_N22GE\20161110_124

Coordinates
 Latitude: North 43 56 21.21809 Compute from PPP
 Longitude: West 72 36 12.56537 Enter Grid Values
 Ellipsoidal height: 405.144 m Enter MSL Height
 Datum: WGS84 Datum Options
 Select From Favorites Add To Favorites Use Average Position

Antenna Height
 From station file: TRM55971.00, NONE View STA File
 Antenna profile: TRM55971.00 Info
 Measured height: 0.000 m
 ARP to L1 offset: 0.067 m
 Applied height: 0.067 m
 Measured to:
 ARP
 L1 Phase Centre
 Compute From Slant

OK Cancel

Flight Log

29178 11-10-16 A

Quantum Spatial
 Project: **CT River VT** Date: **11-10-16 A** Pg. **1** of **2**
 (email log daily to flight_log_distribution_list@quantumspatial.com)
 Flight Mgmt File: **20161110-124708**
 Aircraft: **N22GE** Begin Hobbs: **89573** Total: **89573** Pilot: **TRadtke** Co-Pilot: **JSwan**
 Dep Apt: **KLEB** Dep Time (Lcl): **0800** (Z): **TS** Arr Apt: **KLEB** Arr Time (Local): **1623** (Z): **TS** Tot Time Aloft: **3.4**
 CORS: **GIN** Sta 1: **VTc1** Flyovers: **Y** N If Y, times: **Sta1** **13/14/1611** Sta2)
 GPS Unit: **Y** N Sta 1: Sta 2: Flyovers: **Y** N If Y, times: **Sta1** Sta2)
 Gd Temp beg: **-3** °C End: **4** °C OAT beg: **0** °C End: **2** °C Altimeter begin: **2997** end: **2991**
 LIDAR Type: **ALS70** Serial #: **7161** Alt: **AGL** Alt: **AMSL** Max Gdspd Avg Ft Spading Storage Name/No
 FOV: **40** Scan Freq: **53Hz** MPA: **Y** N In Air: **Phases** Pulse Rate: **260kHz** Power: **100%** PPSM: **017**
 Tot CB: **193** Tot GB: **39**

Line #	Hdg	Start (UTC)	End (UTC)	Gd Spd	PDOP/sats	GPS Altitude	Crab	Turb (0-1)	FLIGHT LINE NOTES - visibility, clouds, smoke, partial, etc
2017	197	1327	1337	164	1.1/17	7363		0	Site → VTc1 0814 → Fig 8's - 1322 Z
2018	17	1341	1351	148	1.2/16	7339		0	
2019	197	1355	1404	165	1.3/16	7306		0	
2020	17	1408	1419	153	1.6/14	7378		0	
2021	197	1423	1433	162	1.5/14	7340		0	
2022	17	1437	1447	152	1.4/14	7377		0	
2023	197	1451	1501	165	1.3/15	7298		0	
2024	17	1505	1515	156	1.1/15	7291		0	
2025	197	1518	1528	158	1.1/15	7299		0	
2026	17	1532	1542	153	1.2/14	7295		0	
2098	290	1552	1603	141	1.2/15	7294		0	Site - Fig 8's 1604 - VTc1 1611
		1604	1608						VTc1 - KLEB
		1611	1623						A ONLINE - 2.5
									MOB - 0.8
									Hobbs 3.3

Total Proj Lines: _____ Lines Flow: _____ Lines Remain: _____ Online Time: **2.5** Mob Time: **0.8** Notes: _____

Nov 10, 2016-A (N73TM, SN7178)

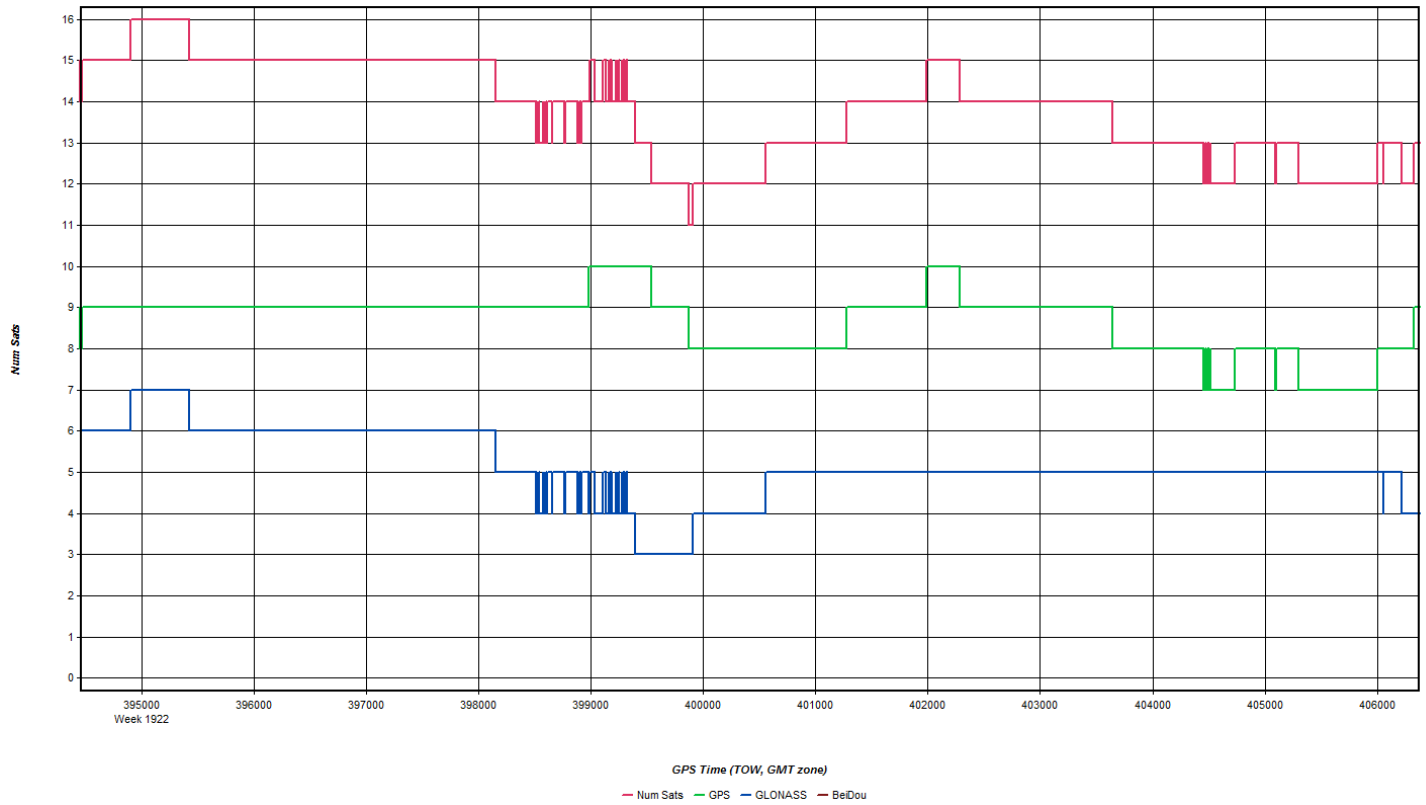
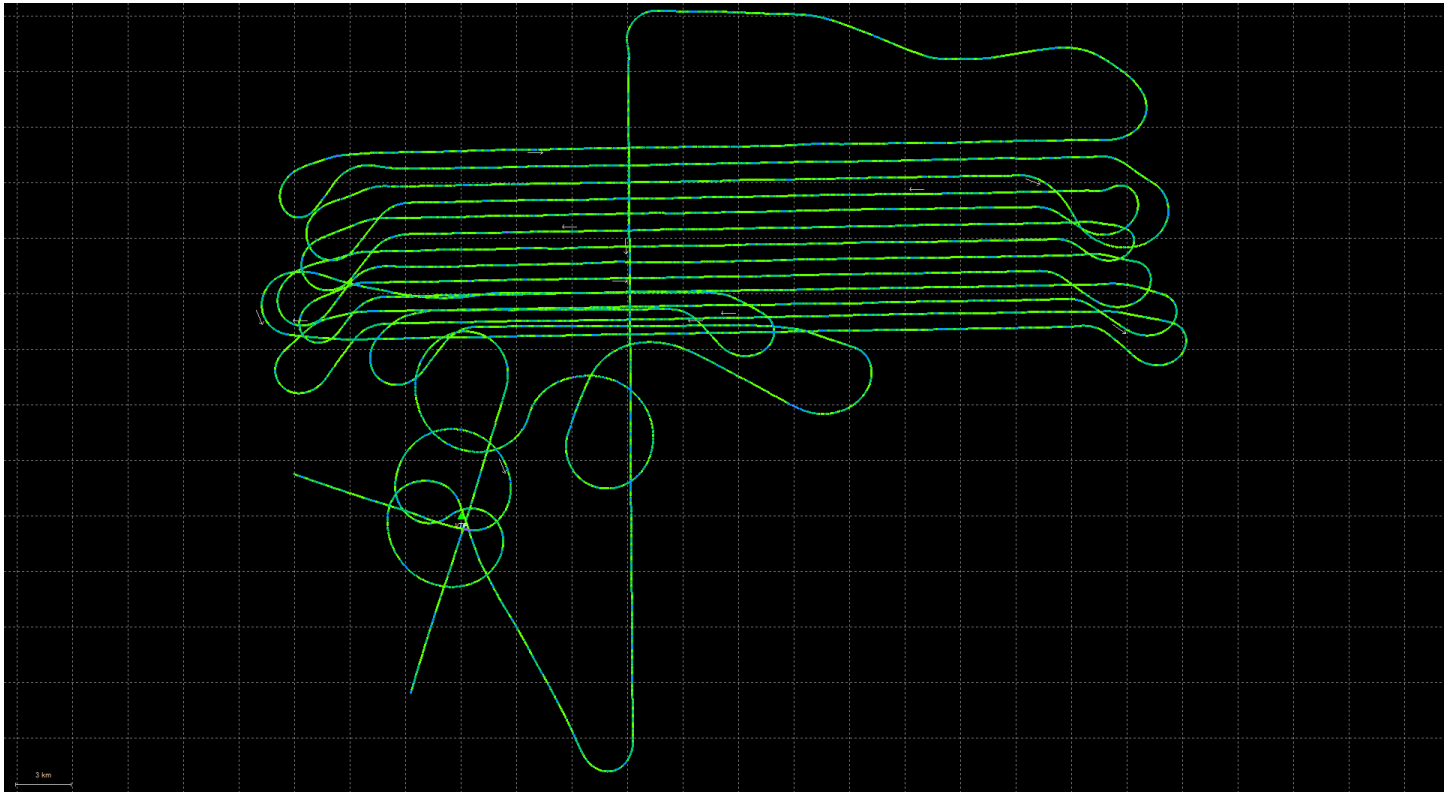

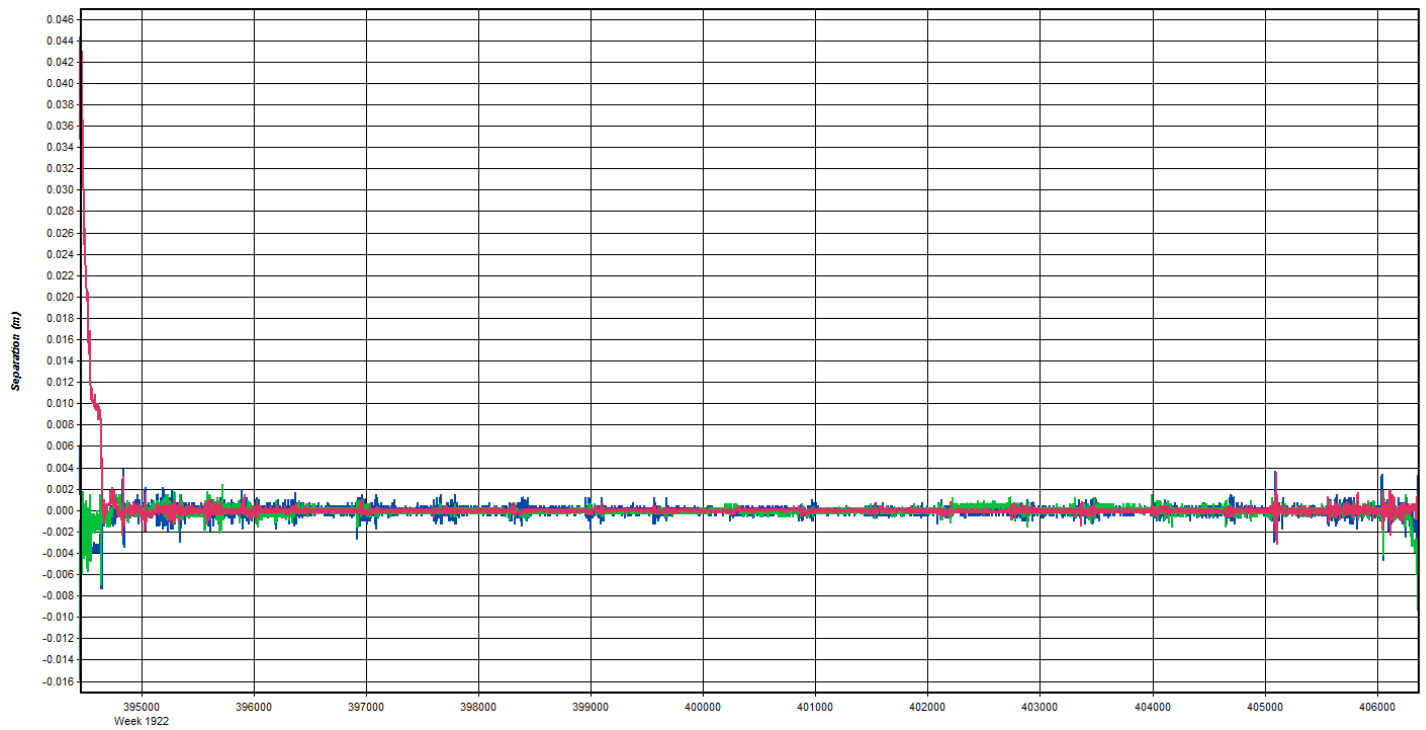

GPS Time (TOW, GMT zone)
— East — North — Up

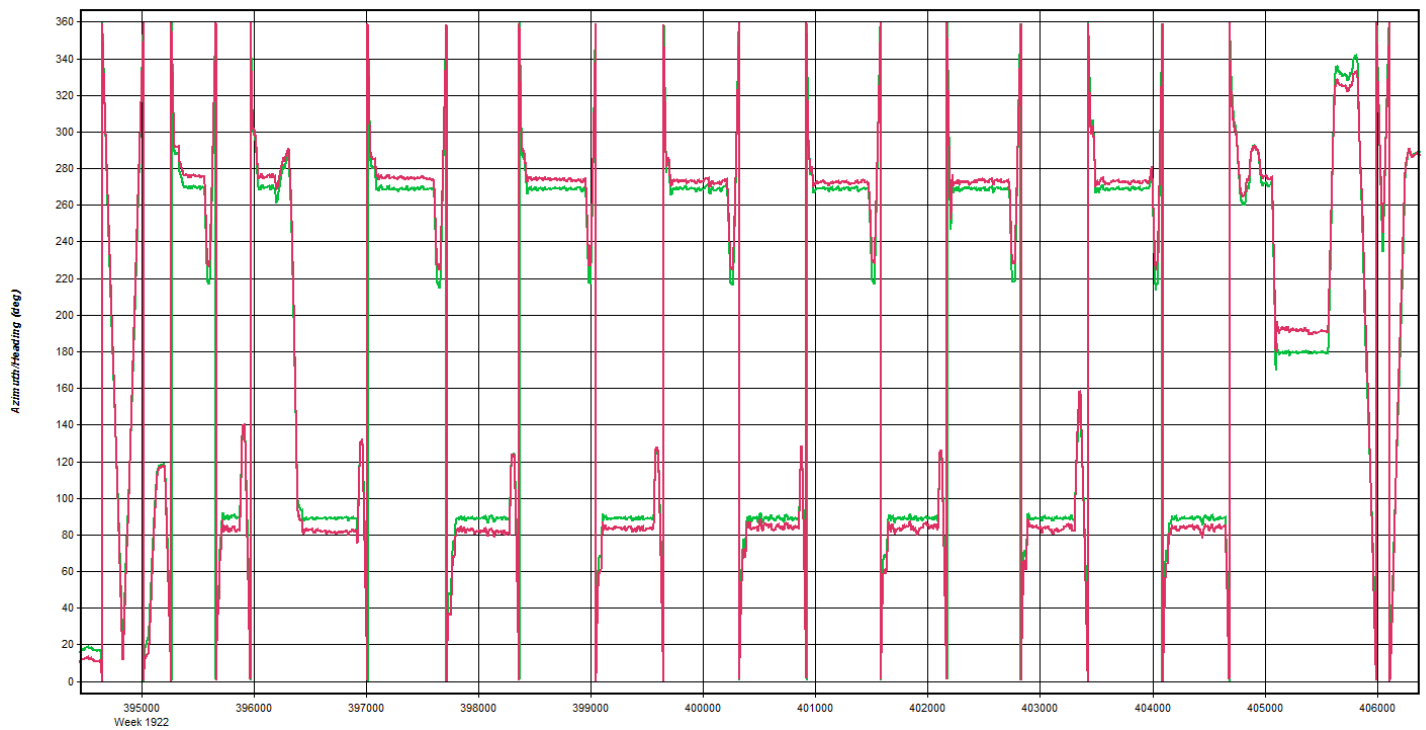

GPS Time (TOW, GMT zone)
— Heading/Azimuth — GPS-COG

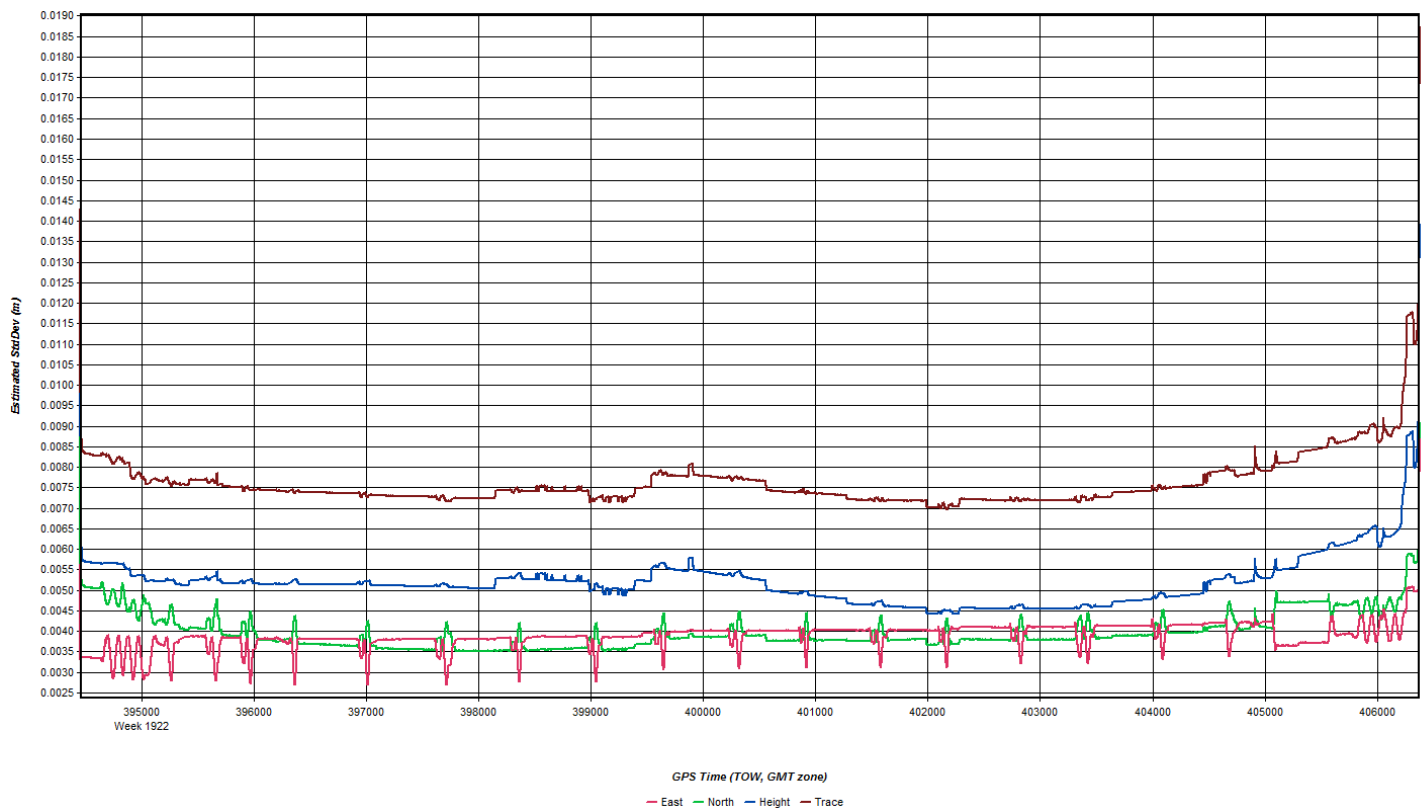
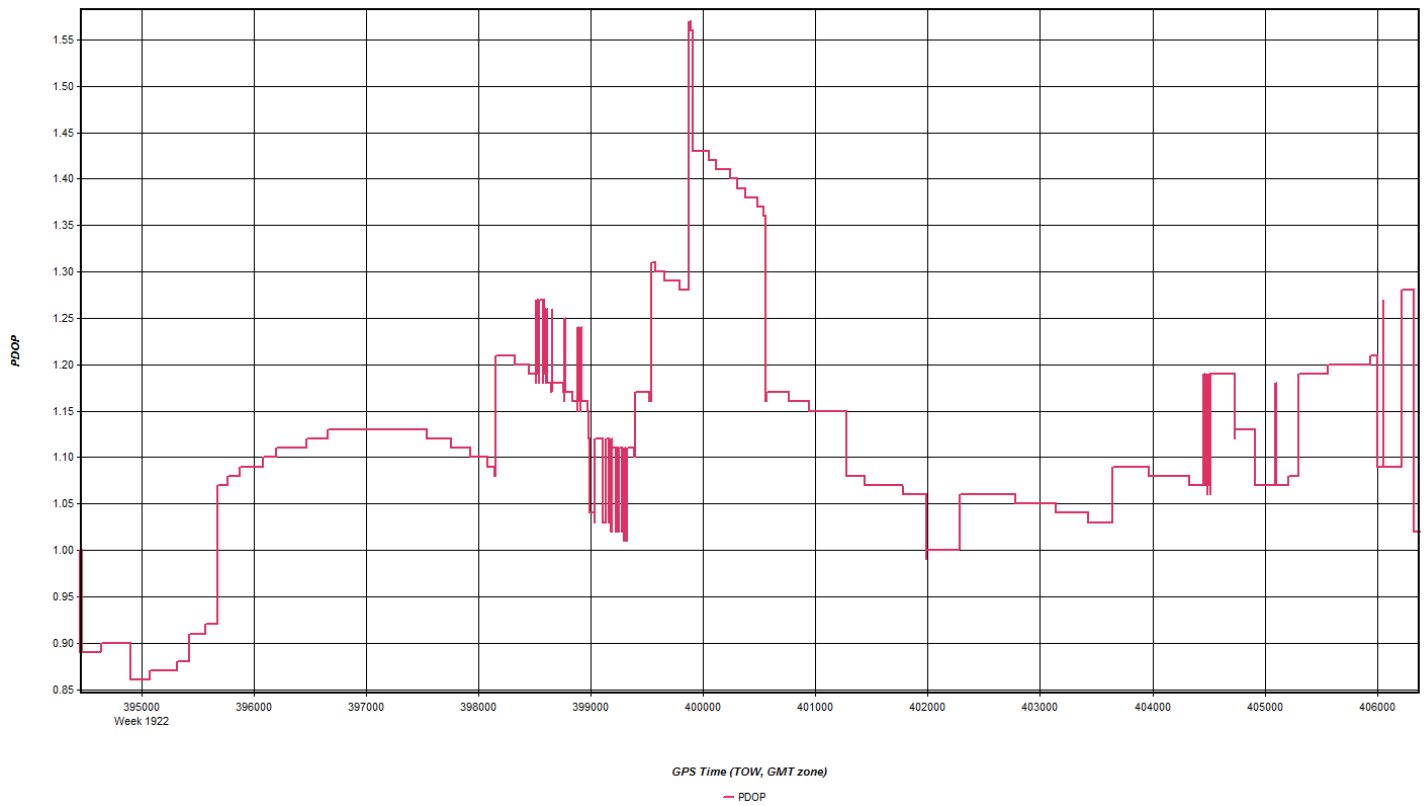

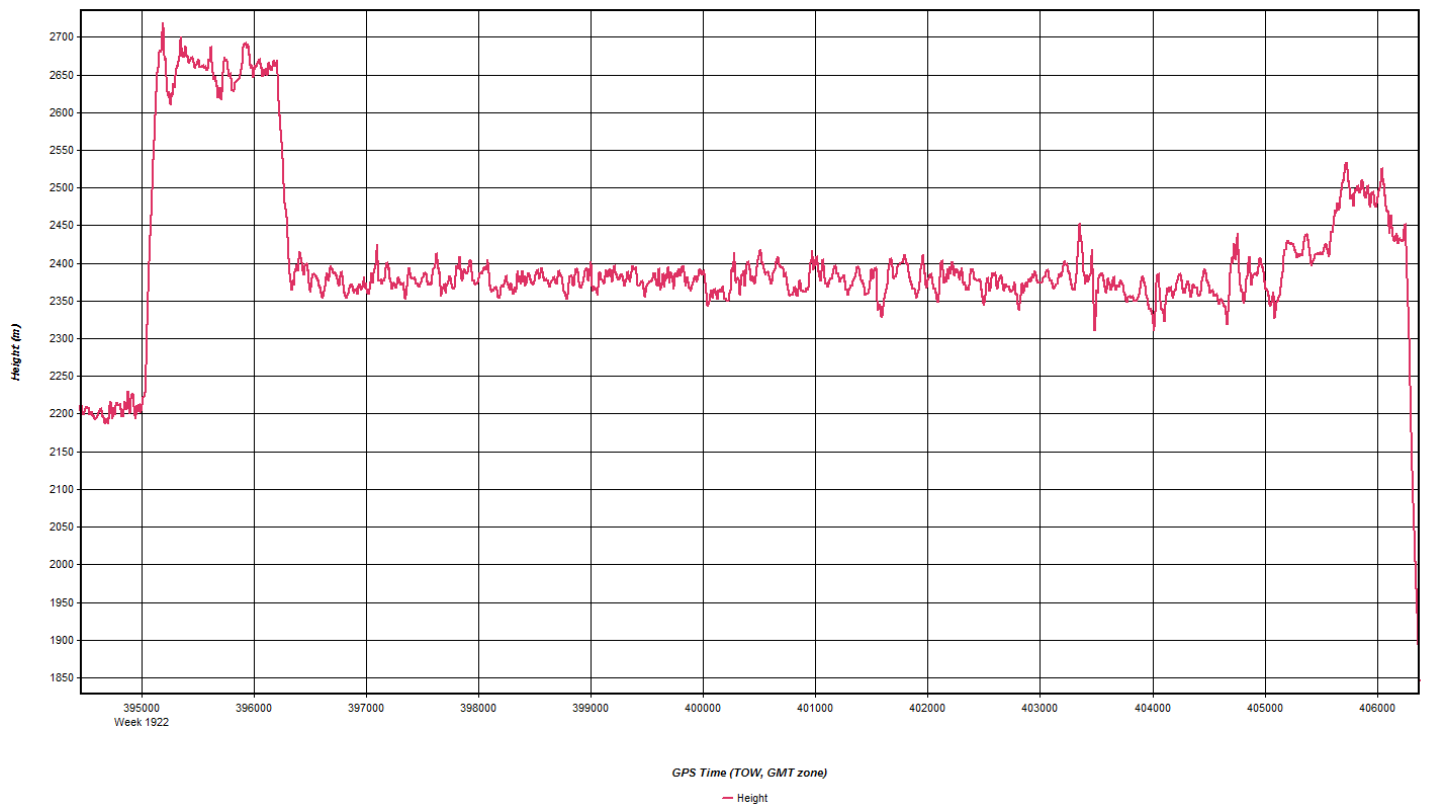
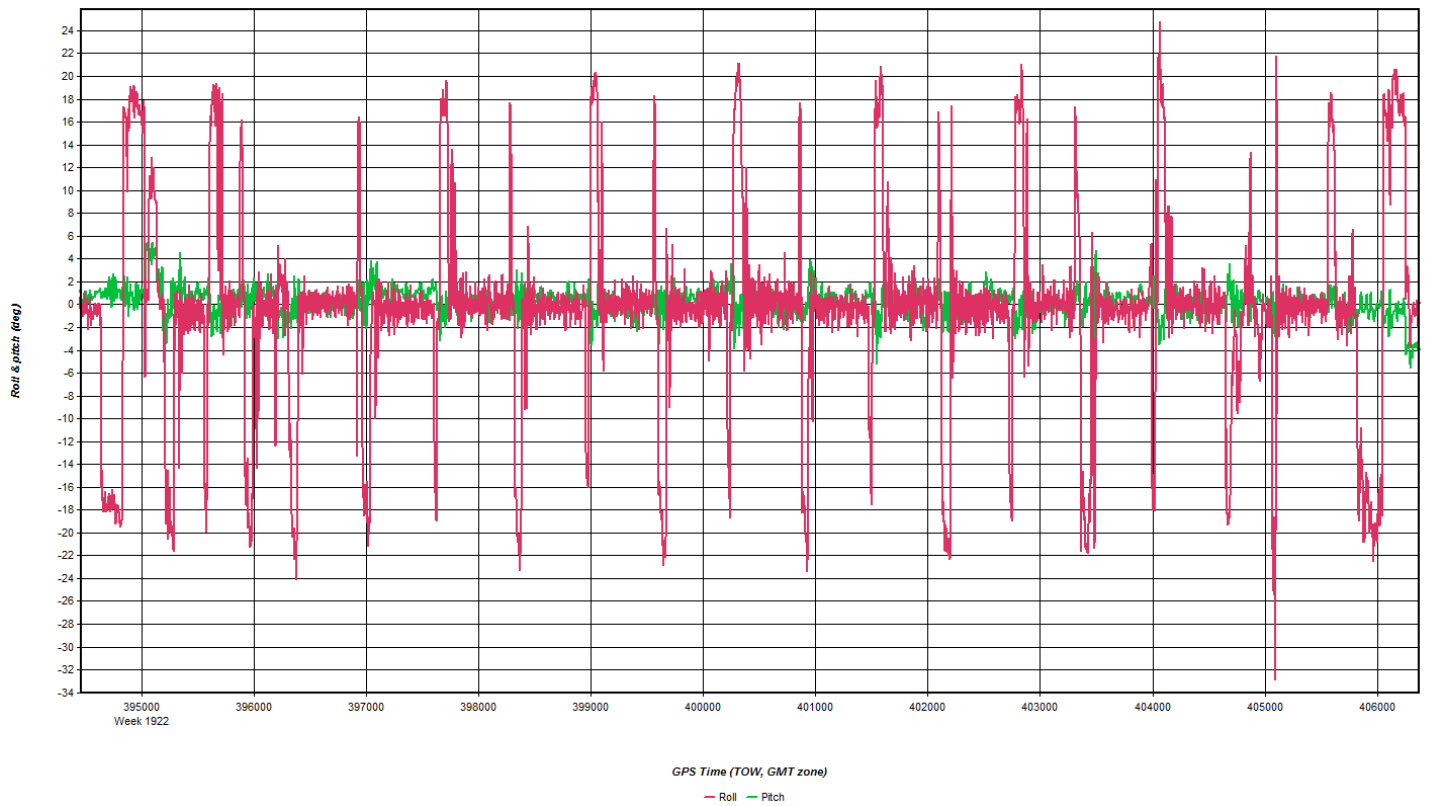

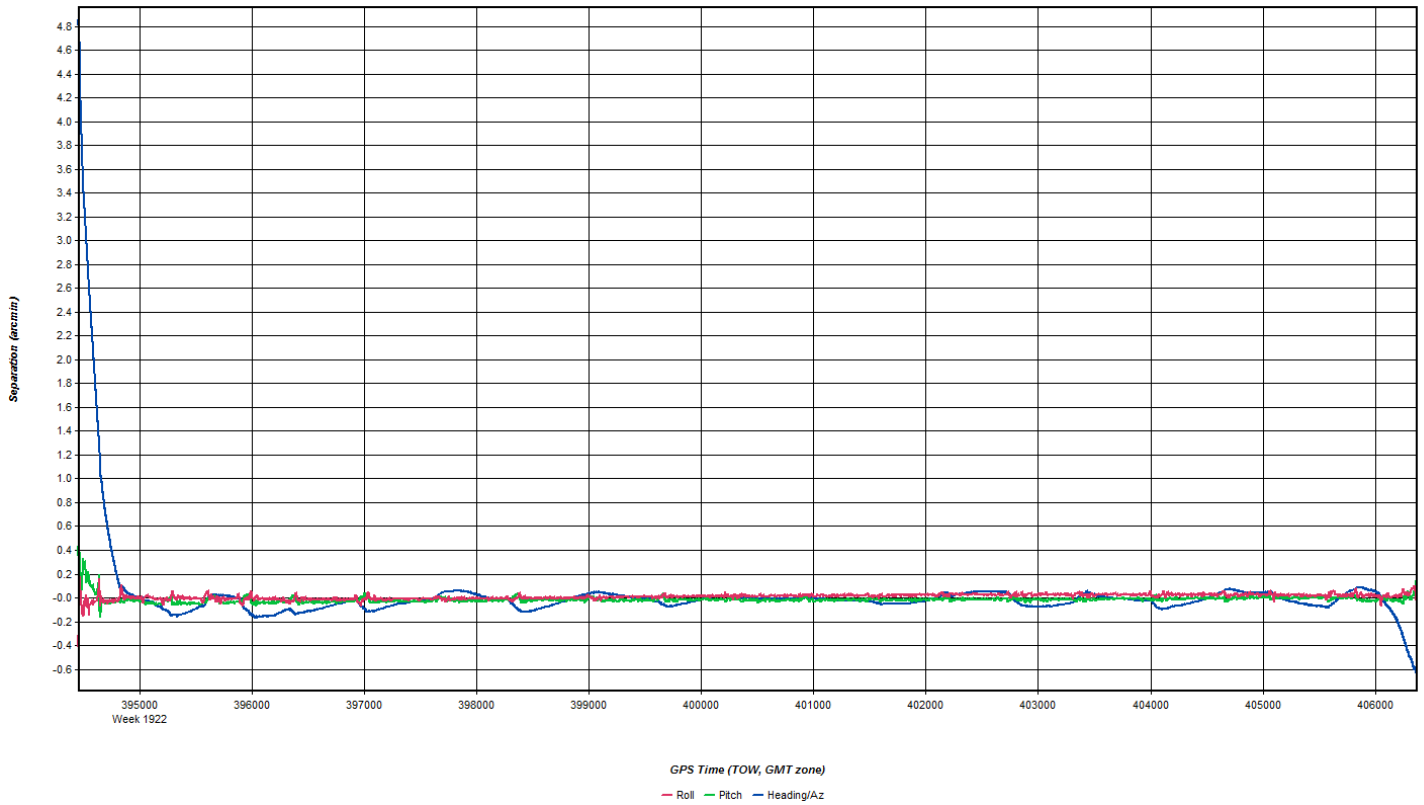

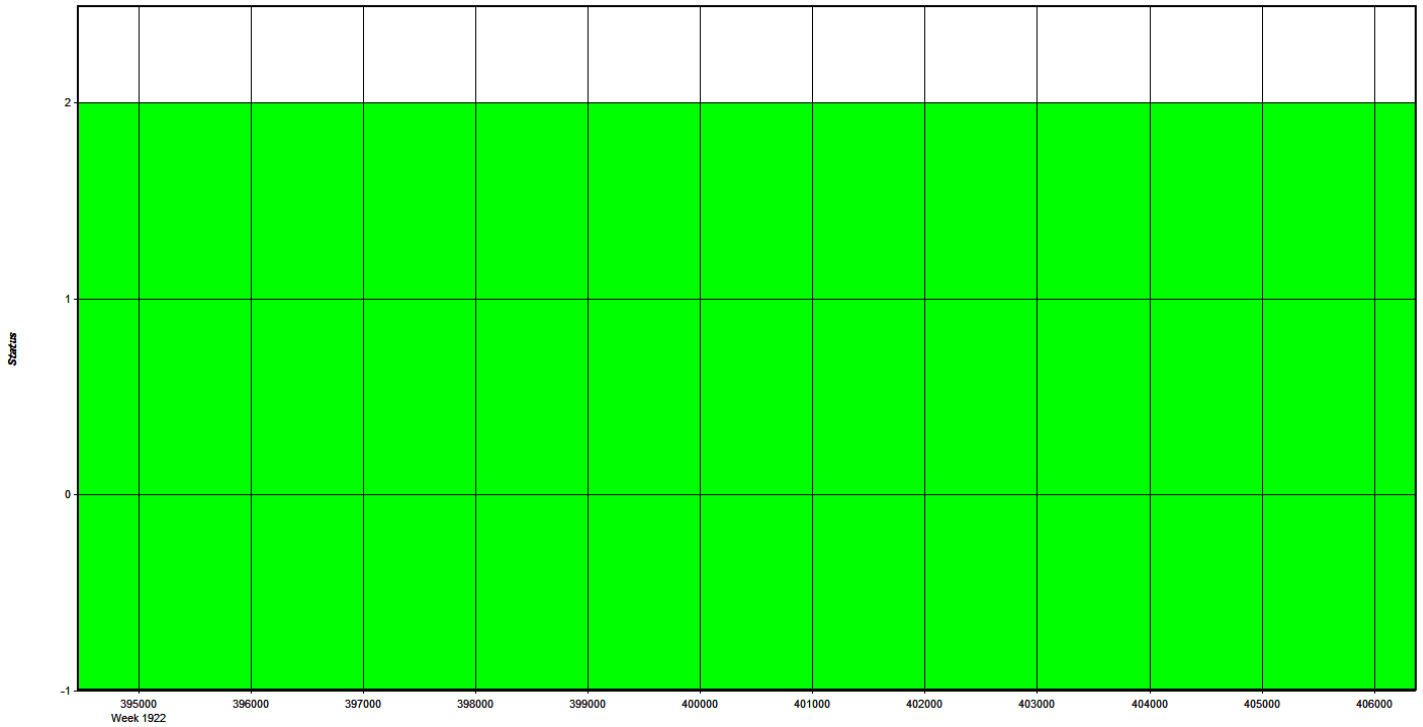

GPS Time (TOW, GMT zone)
 - Float - Forward Fixed - Reverse Fixed - Fixed (2 or more)

Coordinate/Antenna Settings

Master Remote

Base Station
 1: VTIP Name: VTIP Disabled
 File: E:\Proc\29178_VT_CT_River_Basin\20161110_A_B_29178_SN7

Coordinates
 Latitude: North 44 49 12.18043 Compute from PPP
 Longitude: West 71 53 25.83872 Enter Grid Values
 Ellipsoidal height: 341.732 m Enter MSL Height
 Datum: WGS84 Datum Options
 Select From Favorites Add To Favorites Use Average Position

Antenna Height
 From station file: TRM55971.00, NONE View STA File
 Antenna profile: TRM55971.00 Info
 Measured height: 0.000 m
 ARP to L1 offset: 0.067 m
 Applied height: 0.067 m
 Measured to:
 ARP
 L1 Phase Centre
 Compute From Slant

OK Cancel

Flight Log

Airborne LIDAR Data Collection Log Sheet :: Quantum Spatial, Inc

(email log daily to flight_log_distribution_list@quantumspatial.com)

Date: 10/10/16
Lift: (A) B C D E Pg 1 of 1

Project: USGS WinoarCo Proj #: 29178 Flight Mgmt File:
 Aircraft: 737M Begin Hobbs: 6478.3 End Hobbs: 6482.2 Total: 3.9 Pilot: J BARHAM Co-Pilot: M AUST
 Dep Apt: KFR Dep Time (Lcl): 8:00 (Z): 13:00 Arr Apt: EFR Arr Time (Local): 12:00 (Z): 17:00 Tot Time Aloft: 4
 CORs: (Y) N Sta 1: VTIP Sta 2:
 GPS Unit: Y / N Sta 1: Sta 2:
 Flyovers: (Y) N If Y, times: Sta1) 13:34 Sta2)
 Flyovers: Y / N If Y, times: Sta1) Sta2)

Gd Temp beg: - / °C End: # °C OAT beg: °C End: °C Altimeter begin: 2897 end: 2982
 Type: MLS 70 Serial #: 7178 Max Gdspd: Avg Pt Spacing: 580
 FOV: 40 Scan Freq: 53 MPIA Y / N Pulses In Air: 260 Power: 100 PFSM: 4
 Bag GB: 418 End GB: 378 Tot GB: 4
 Storage Name/ #: 4

Line #	Hdg	Start (UTC)	End (UTC)	Gd Spd	FOOPI/sats	GPS Altitude	Crab	Turb (0-4)	FIGHT LINE NOTES - visibility, clouds, smoke, partial, etc.
4073	W	1350	1352	153	13/16	8.8			
4041	E	1355	1357	156	13/16	8.7			
4040	W	1400	1402	146	13/16	8.7			
4015	E	1407	1414	152	14/15	7.8			
4014	W	1418	1426	147	14/15	7.8			
4013	E	1430	1437	155	13/15	7.8			
4012	W	1441	1448	143	12/16	7.8			
4011	E	1457	1459	152	12/15	7.8			
4010	W	1503	1509	142	11/17	7.8			
4009	E	1513	1520	149	13/15	7.8			
4008	W	1523	1530	142	13/14	7.8			
4007	E	1534	1541	149	12/15	7.8			
4006	W	1544	1551	132	12/15	7.8			
4005	E	1555	1601	171	12/15	7.8			
4004	W	1604	1612	148	13/14	7.8			
4003	E	1616	1625	157	11/16	7.8			
4099	S	1631	1639	155	11/17	7.8			

WINDS 295 @ 30 kts

WINDS 289 @ 30 kts

Cross FLIGHT

Total Proj Lines: Lines Flown: Lines Remain: Online Time: 2.75 Mob Time: 1.25 Notes:

Nov 10, 2016-B (N22GE, SN7161)

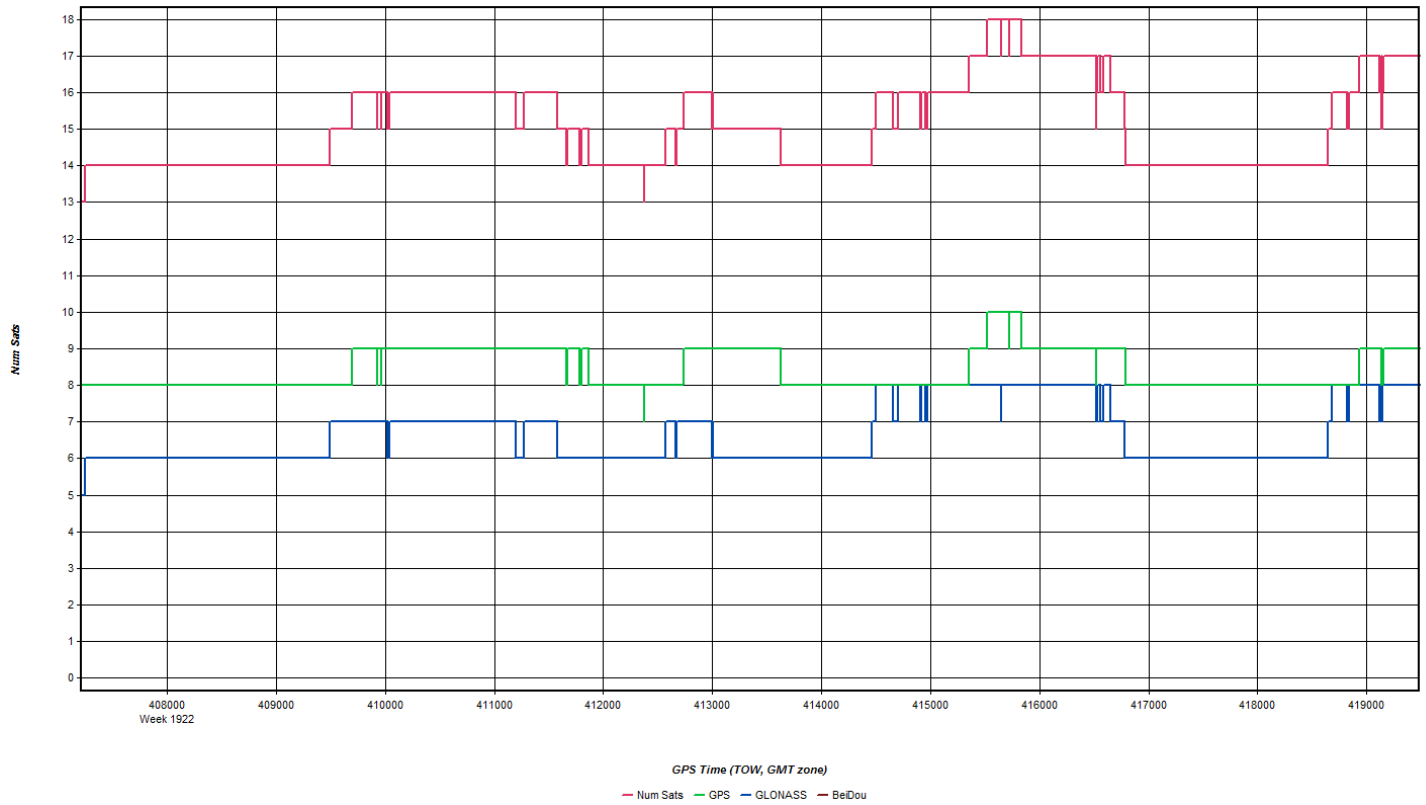
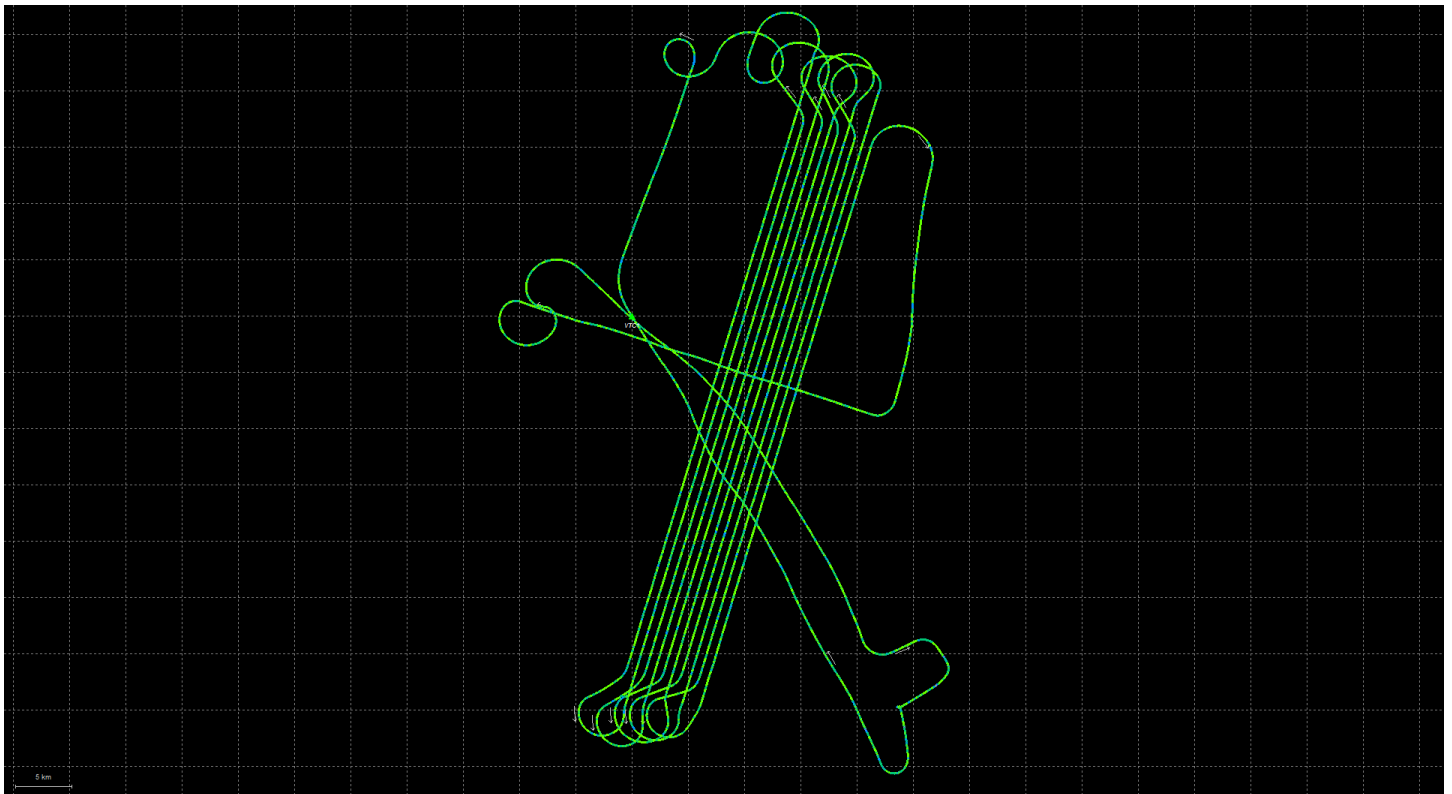

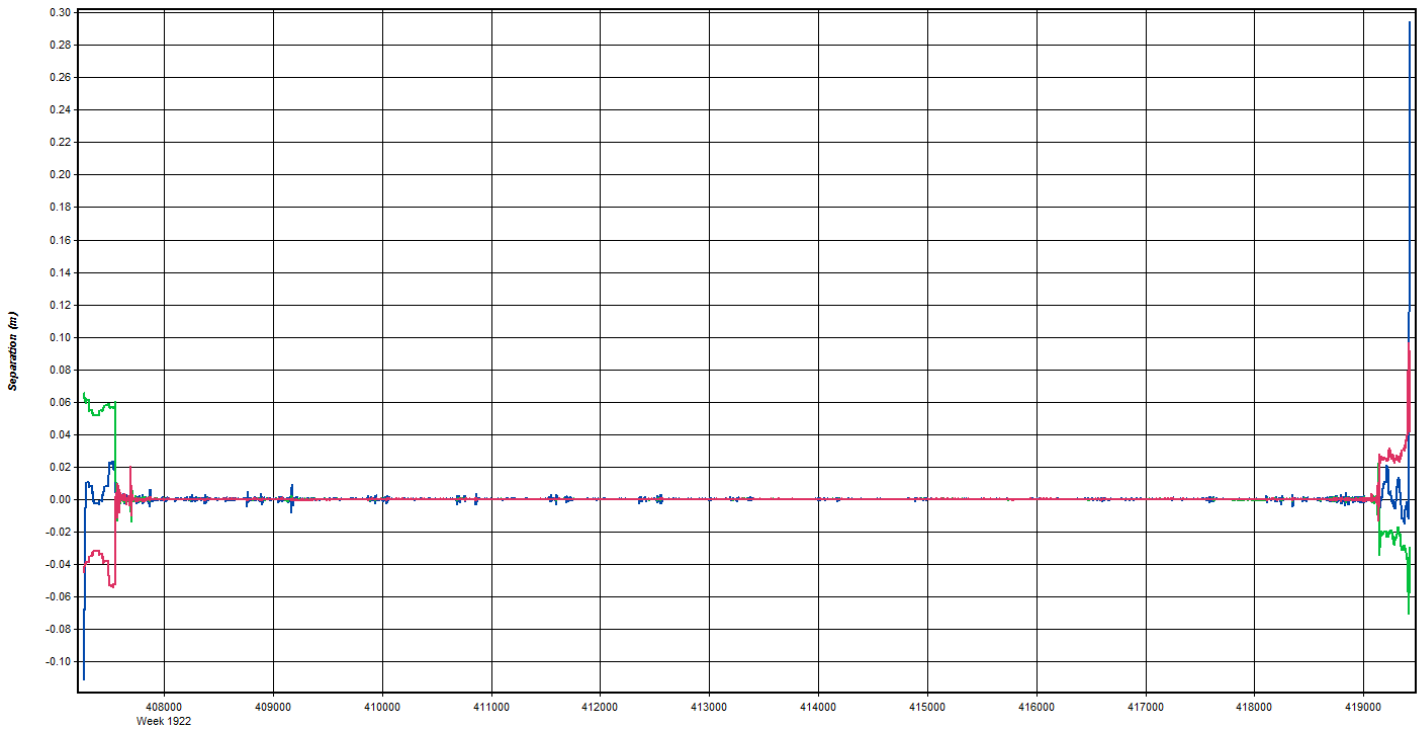

GPS Time (TOW, GMT zone)
— East — North — Up

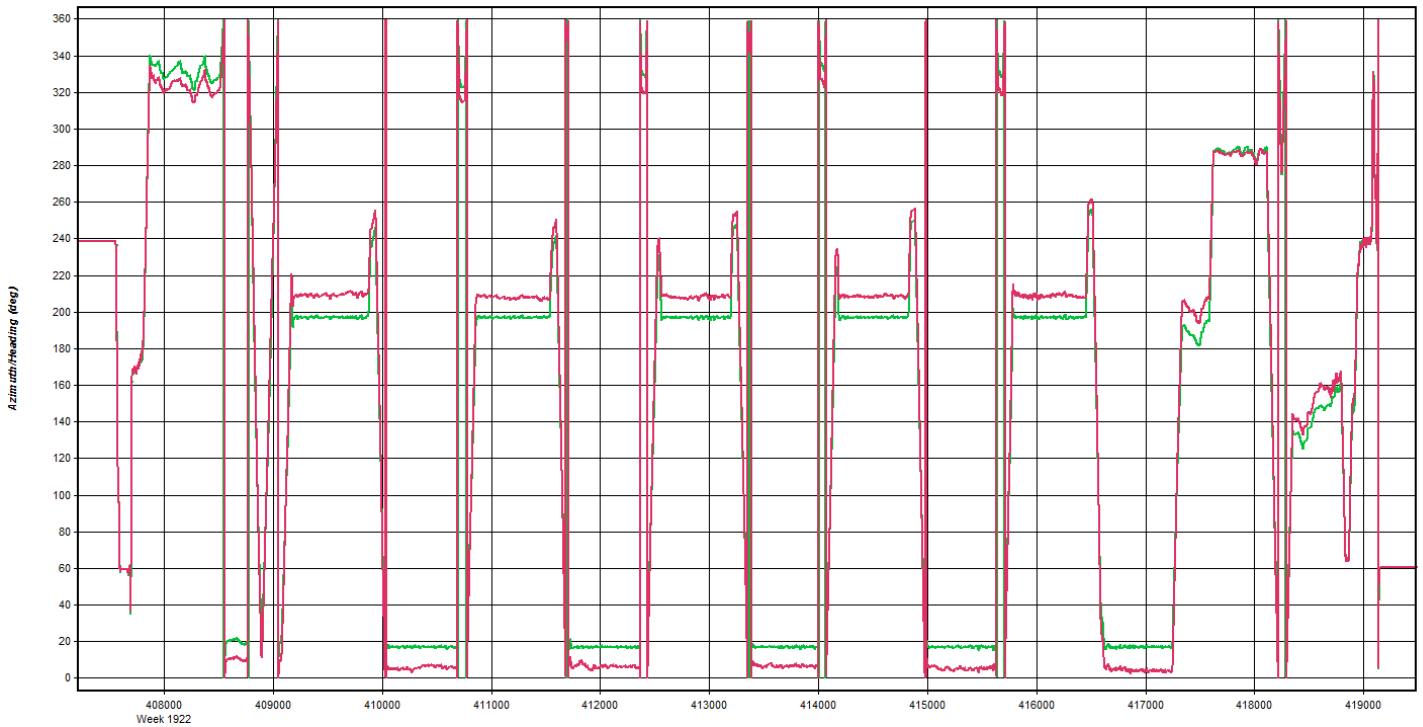

GPS Time (TOW, GMT zone)
— Heading/Azimuth — GPS-COG

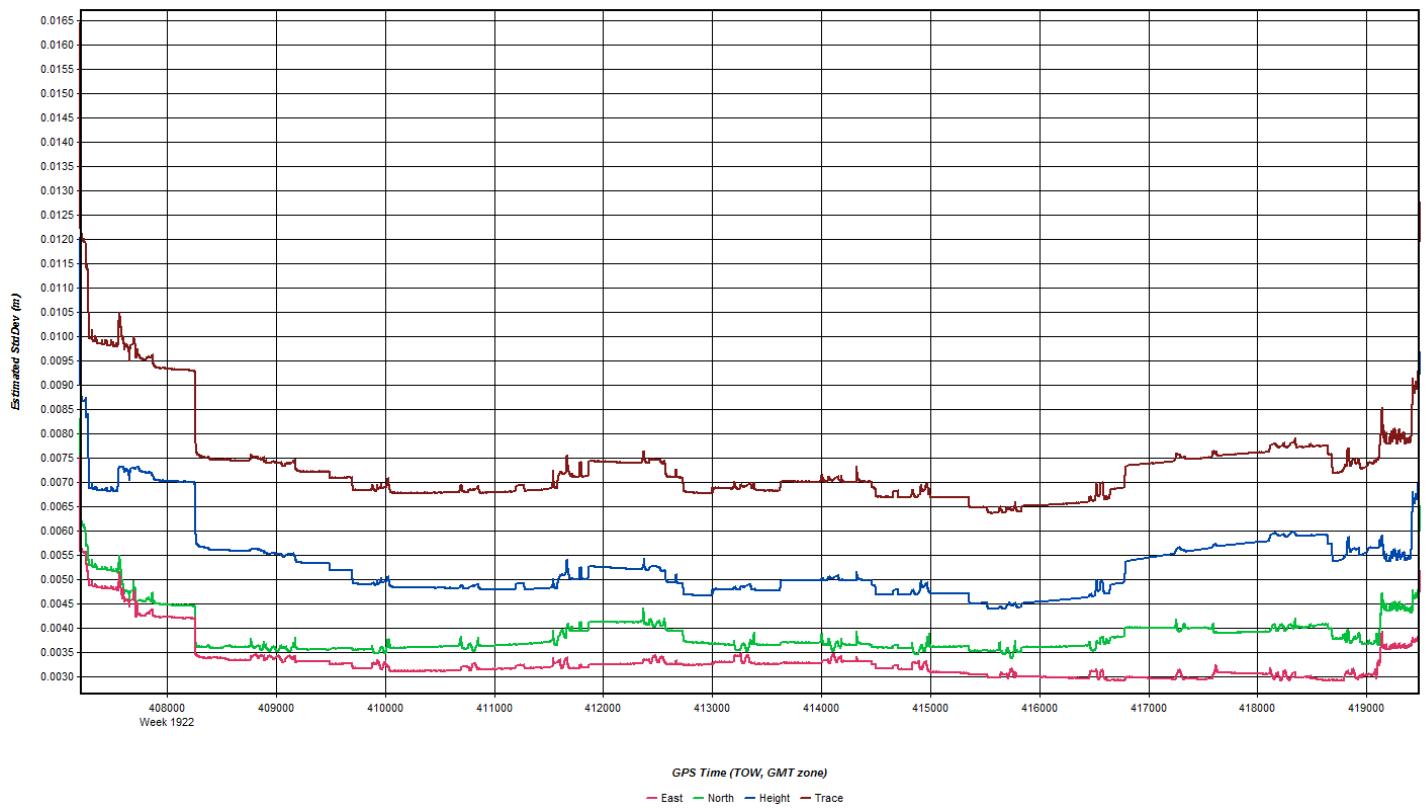
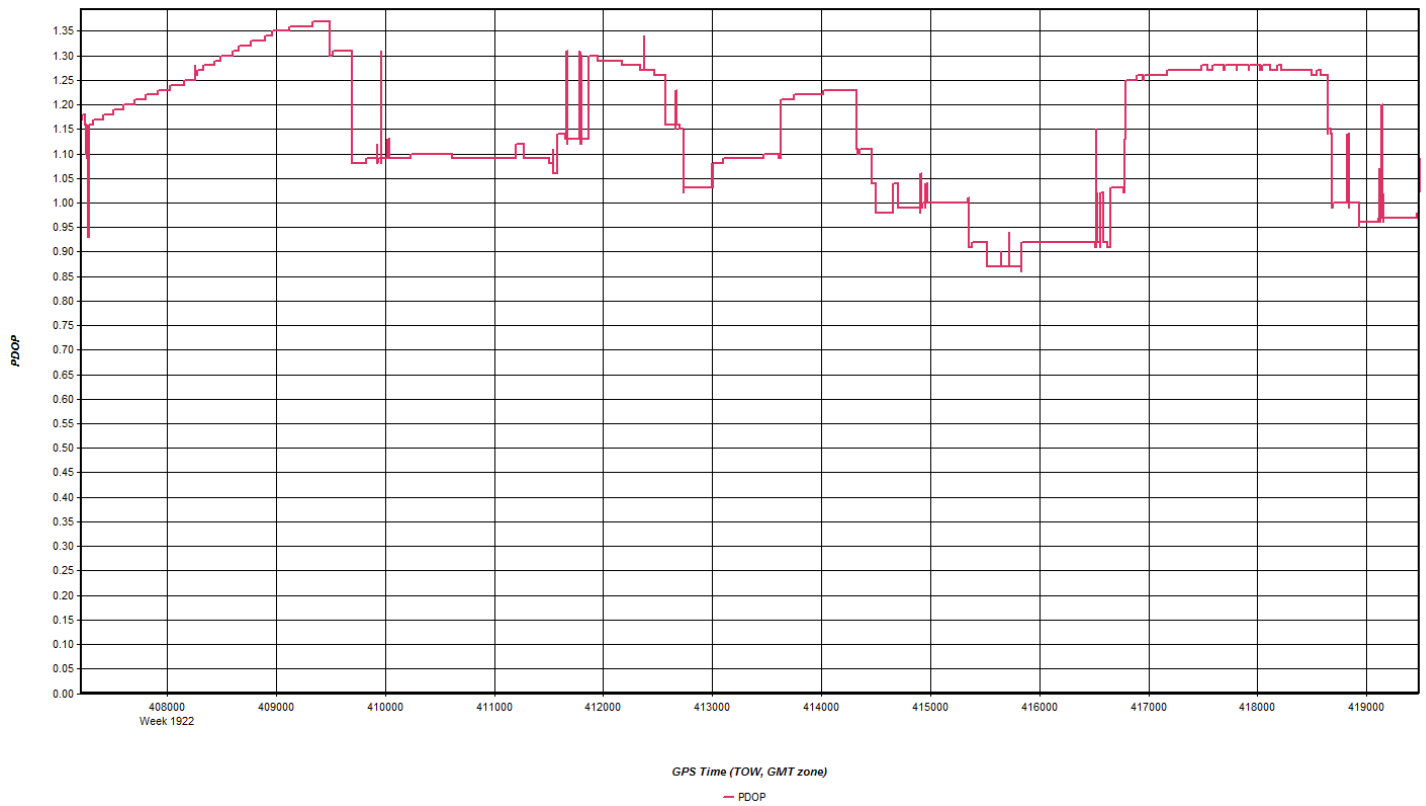

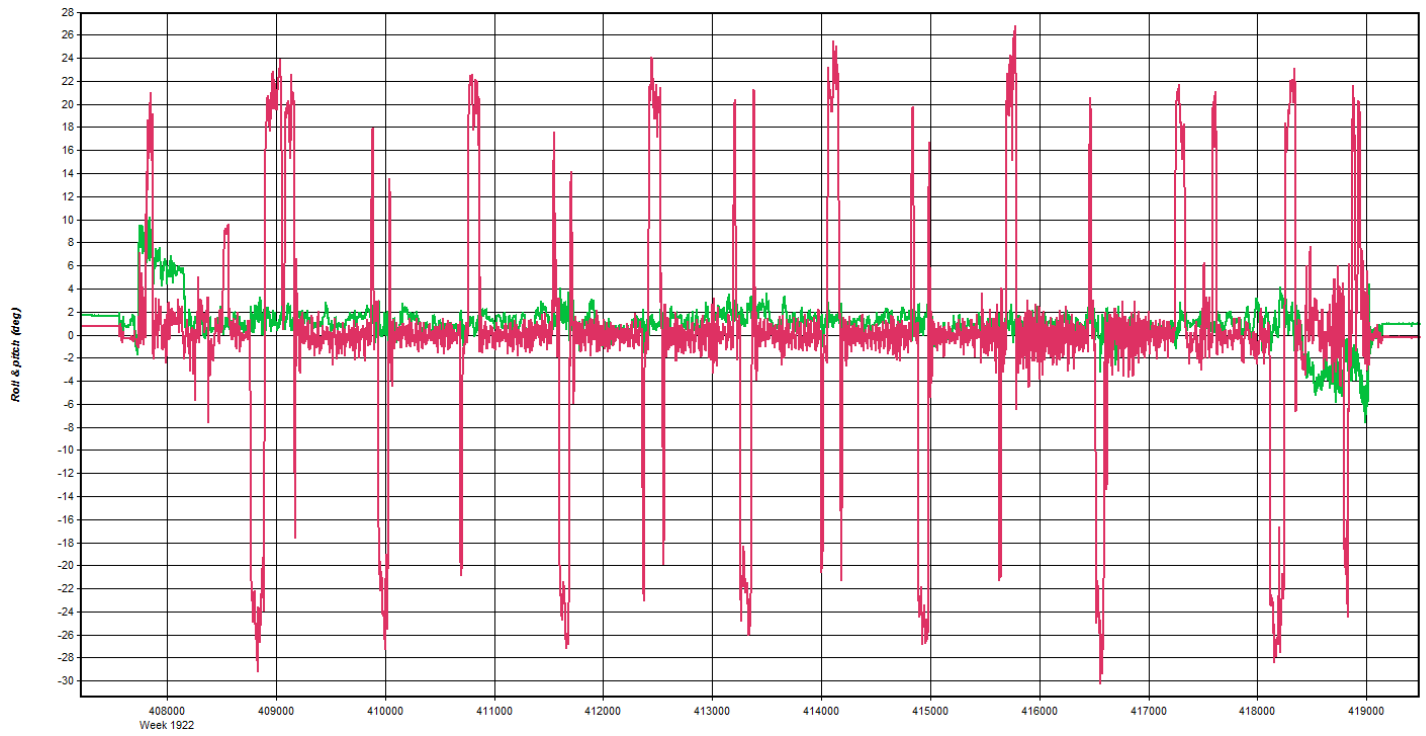

GPS Time (TOW, GMT zone)
— Roll — Pitch

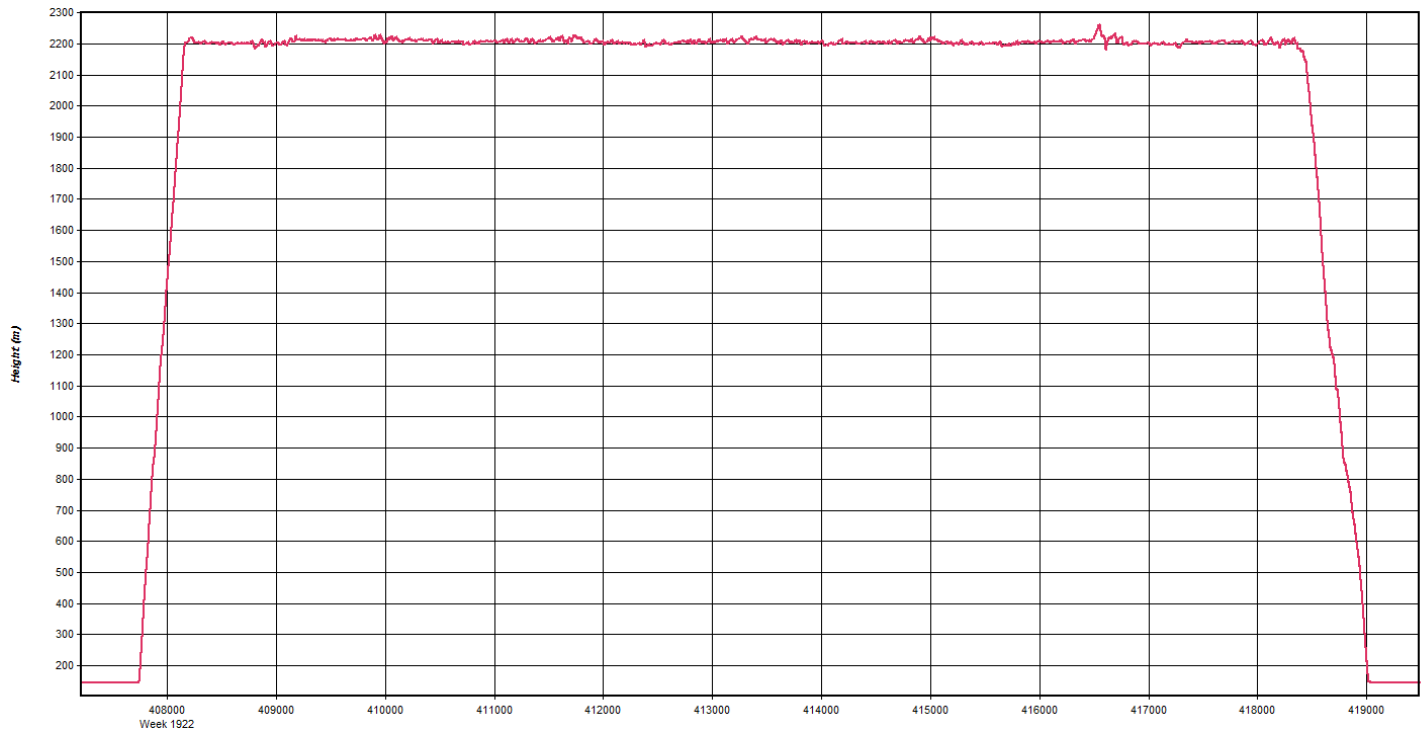

GPS Time (TOW, GMT zone)
— Height

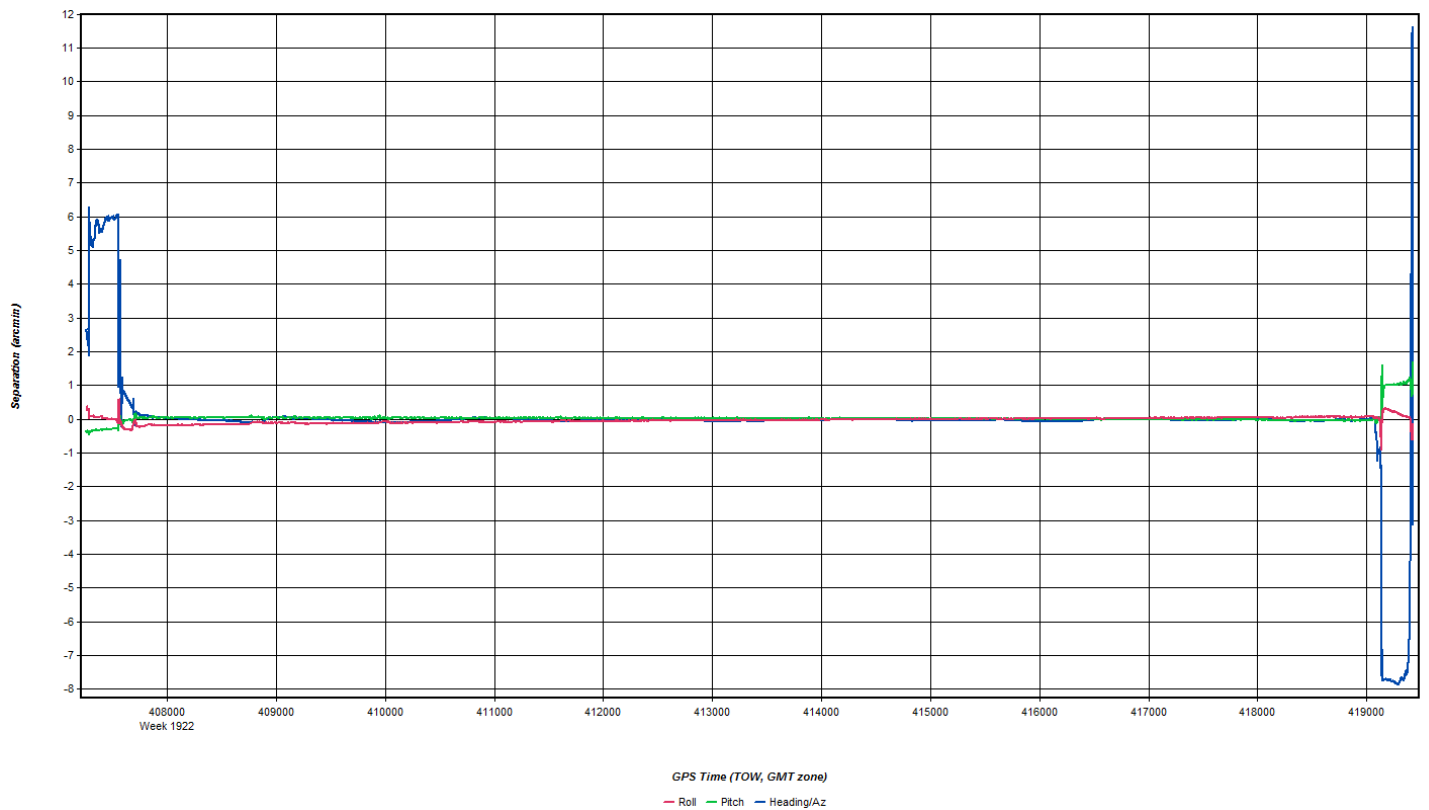
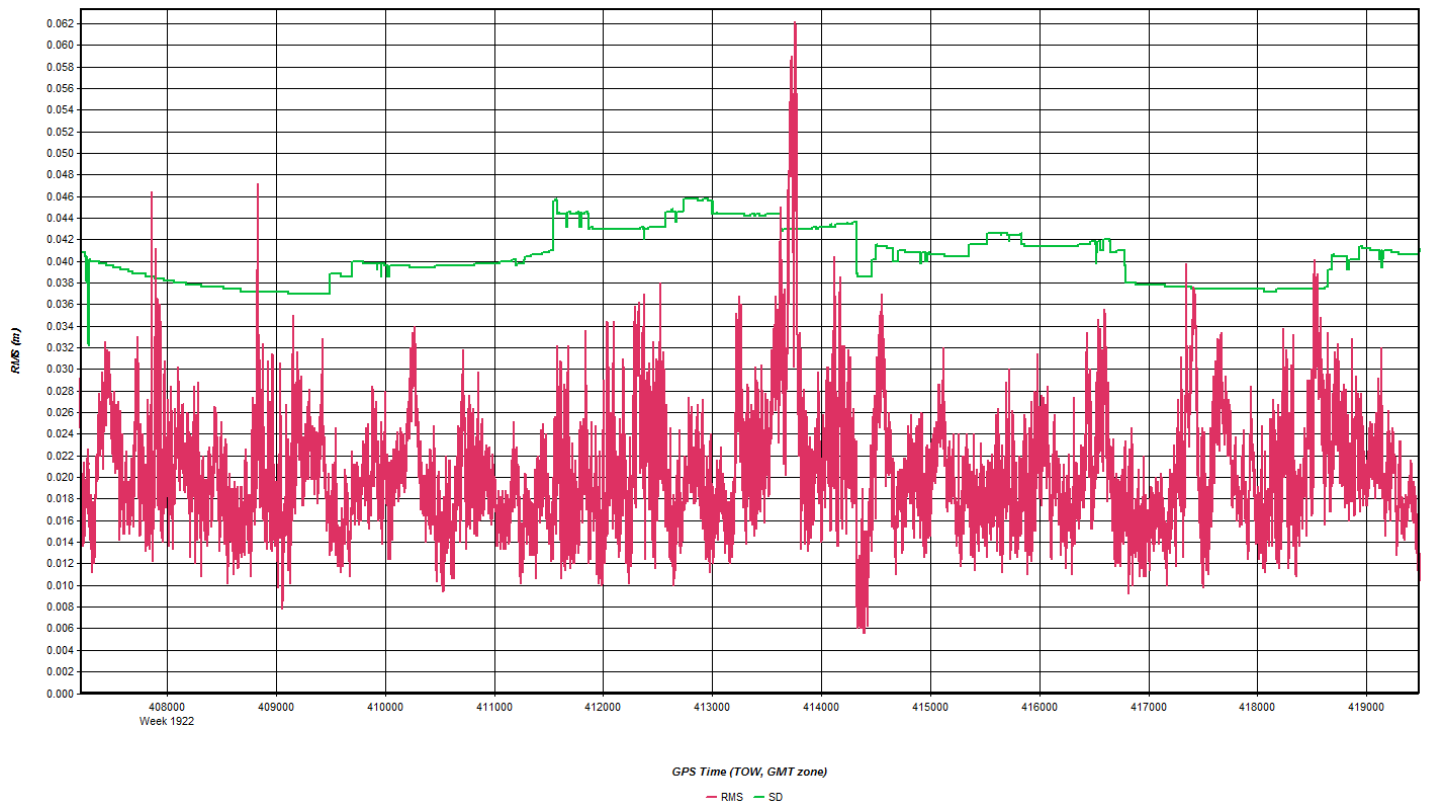

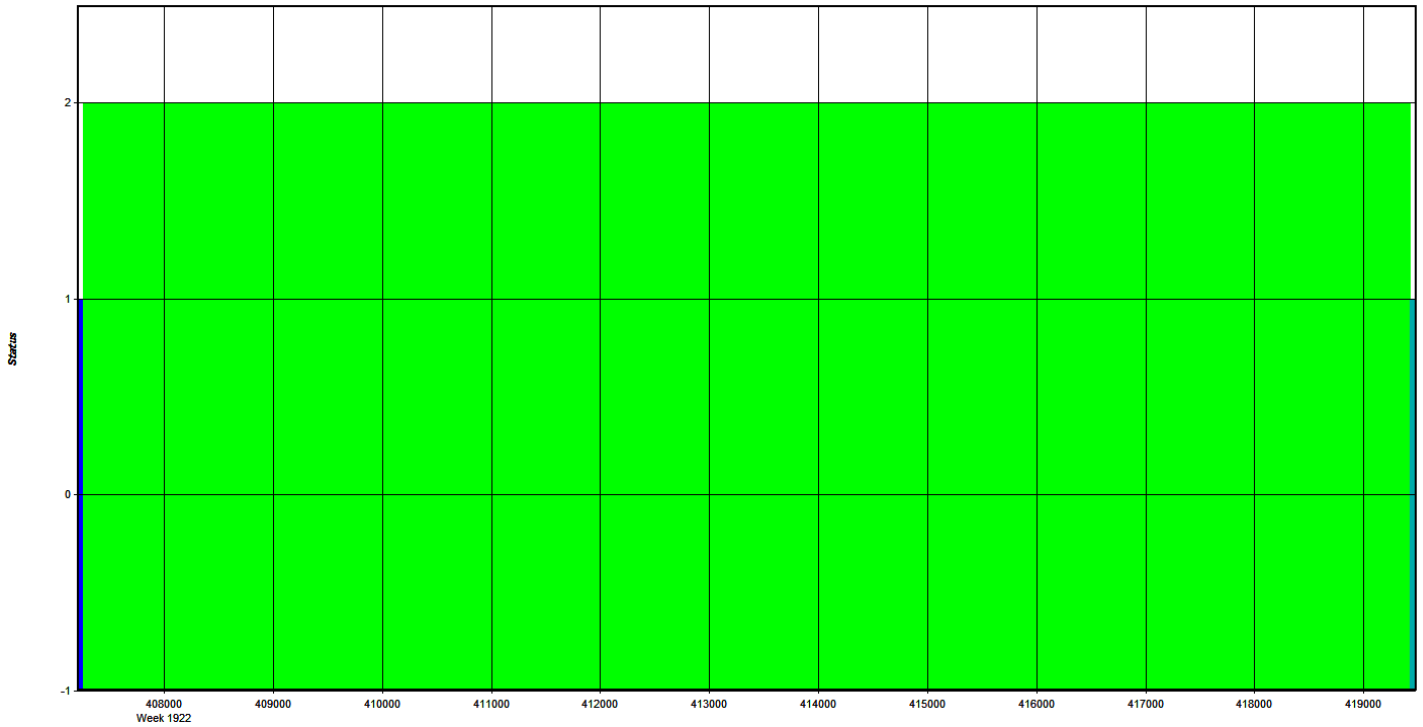

GPS Time (TOW, GMT zone)
 - Float - Forward Fixed - Reverse Fixed - Fixed (2 or more)

Coordinate/Antenna Settings

Master Remote

Base Station
 1: VTC1 Name: VTC1 Disabled
 File: E:\Proc\29178_CT_River\29178_ALS70_N22GE\20161110_170

Coordinates
 Latitude: North 43 56 21.21809 Compute from PPP
 Longitude: West 72 36 12.56537 Enter Grid Values
 Ellipsoidal height: 405.144 m Enter MSL Height
 Datum: WGS84 Datum Options
 Select From Favorites Add To Favorites Use Average Position

Antenna Height
 From station file: TRM55971.00, NONE View STA File
 Antenna profile: TRM55971.00 Info
 Measured height: 0.000 m
 ARP to L1 offset: 0.067 m
 Applied height: 0.067 m
 Measured to
 ARP
 L1 Phase Centre
 Compute From Slant

OK Cancel

Flight Log

29178 11-10-16-B

Q Airborne LiDAR Data Collection Log Sheet :: Quantum Spatial, Inc

Date: 11-10-16 B
Ufr: A B C D E
Pg 2 of 3

Project: 29178 CT River-VT Proj #: 29178 Flight Mgmt File: Zol61110_170201
 Aircraft: N226E Begin Hobbs: 8960.5 End Hobbs: 8960.5 Total: 3.2 Pilot: LEADTKE Co-Pilot: TSWAN Tech: TSWAN
 Dep Apt: KLEB Dep Time (Local): 1716 (Z): TS Arr Apt: KLEB Arr Time (Local): (Z): TS Tot Time Aloft: 3.3
 CORS: (Y)N Sta 1: VTCL Flyovers: (Y)N IF Y, times: Sta 1) 1728/2013 Sta 2) Flyovers: Y / N IF Y, times: Sta 1) Sta 2)
 GPS Unit: Y / N Sta 1: Sta 2: Altimeter begin: 2985 end: 2985
 Gd Temp beg: TS °C End: 11 °C OAT beg: +3 °C End: +4 °C Avg Terr Ht Max Gsppd Avg Pt Spading
 LIDAR Type ALS70 Serial # 7161 Alt ANSL Pulses Power: 100% PPSM
 FOV 40 Hz MpiA Y / N Pulses In Air Rate 260 kHz

Line #	Hdg	Start (UTC)	End (UTC)	Gd Spd	POW/sats	GPS Altitude	Crab	Turb (0-1)	Notes
2027	197	1728	1735	151	11/17	7225	250	0	LEB → VTCL-1788 - fig 8's 1735
2028	17	1754	1804	159	11/18	7262	30	0	270 bank!
2029	17	1808	1818	141	12/16	7214	28	0	
2030	17	1822	1831	152	11/17	7263	4	0	
2031	197	1836	1845	128	11/17	7214	27	0	
2032	17	1849	1859	153	12/16	7274	3	0	
2033	197	1903	1913	145	10/18	7264	27	0	
2034	17	1917	1926	181	10/18	7277	3	0	
2035	197	1930	1940	153	11/18	7232	28	0	GPS Crab 14 / Compass 28
2036	17	1944	1953	150	10/18	7225	3	0	30° roll in turn!
X61e	287	2000	2008	140	14/15	7198	0	0	Fig 8's 2008-VTCL -LEB 1110 Total Hobbs = 6.5
		2008-2013		Fig 8's					B Hobbs = 3.2 1110 total ONLINE = 4.7
		2013-2013		Fig 8's VTCL					B ONLINE = 2.2 1110 total MOB = 1.8
		2013-		VTCL-LEB					B MOB = 1.0

FLIGHT LINE NOTES - visibility, clouds, smoke, partial, etc

Total Prof Lines: Lines Flow: 10 Online Time: 2.2 Mob Time: 1.0 Notes:

Nov 10, 2016-B (N73TM, SN7178)

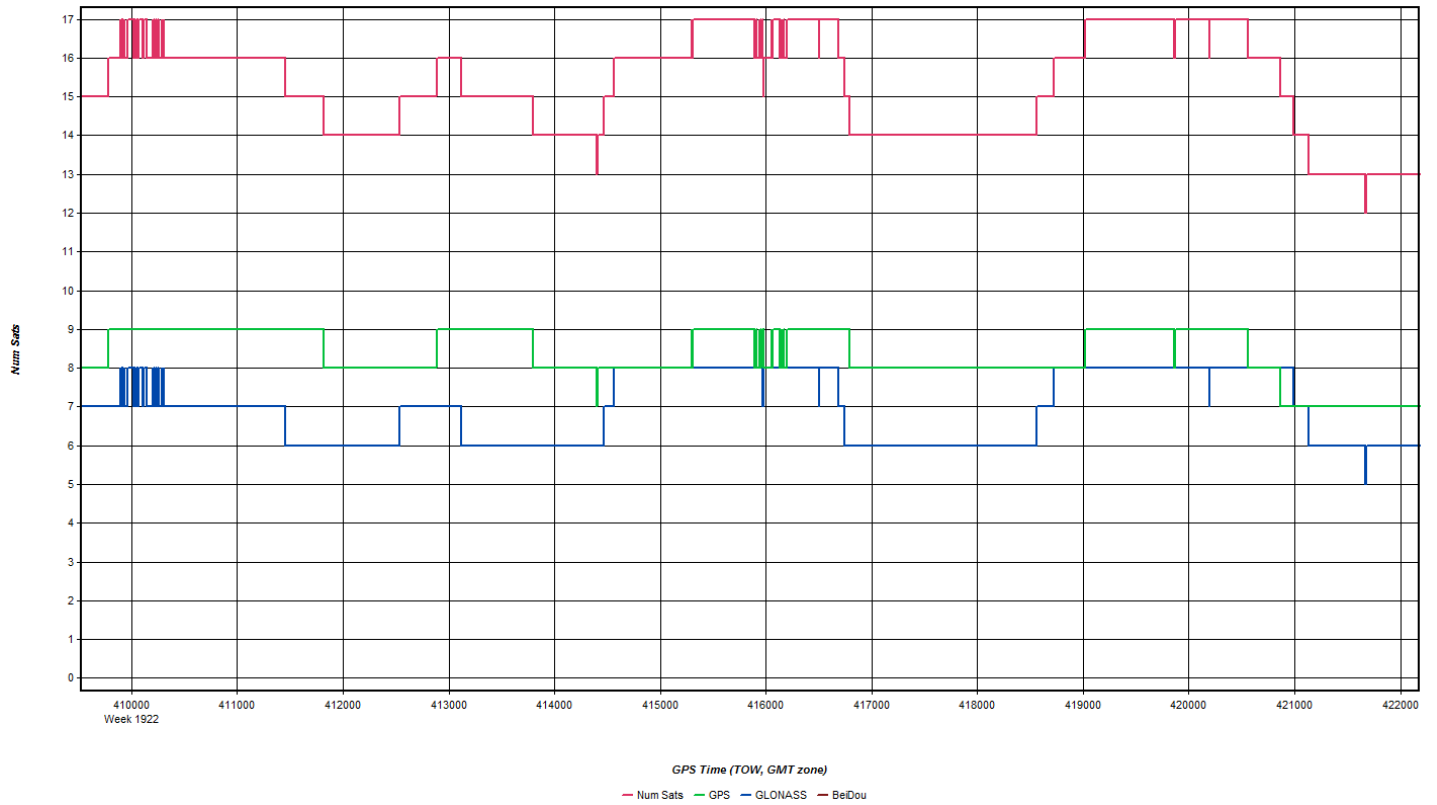
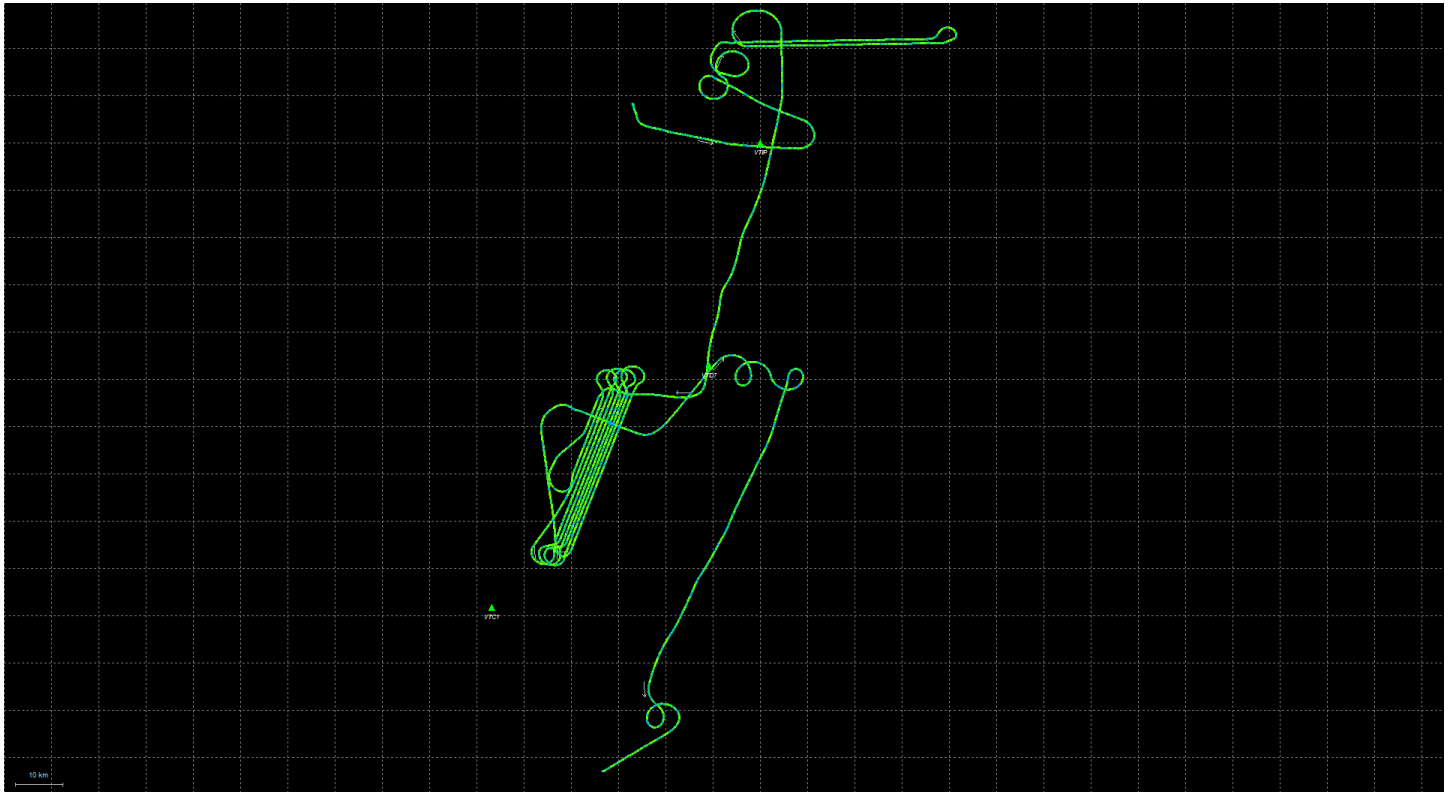

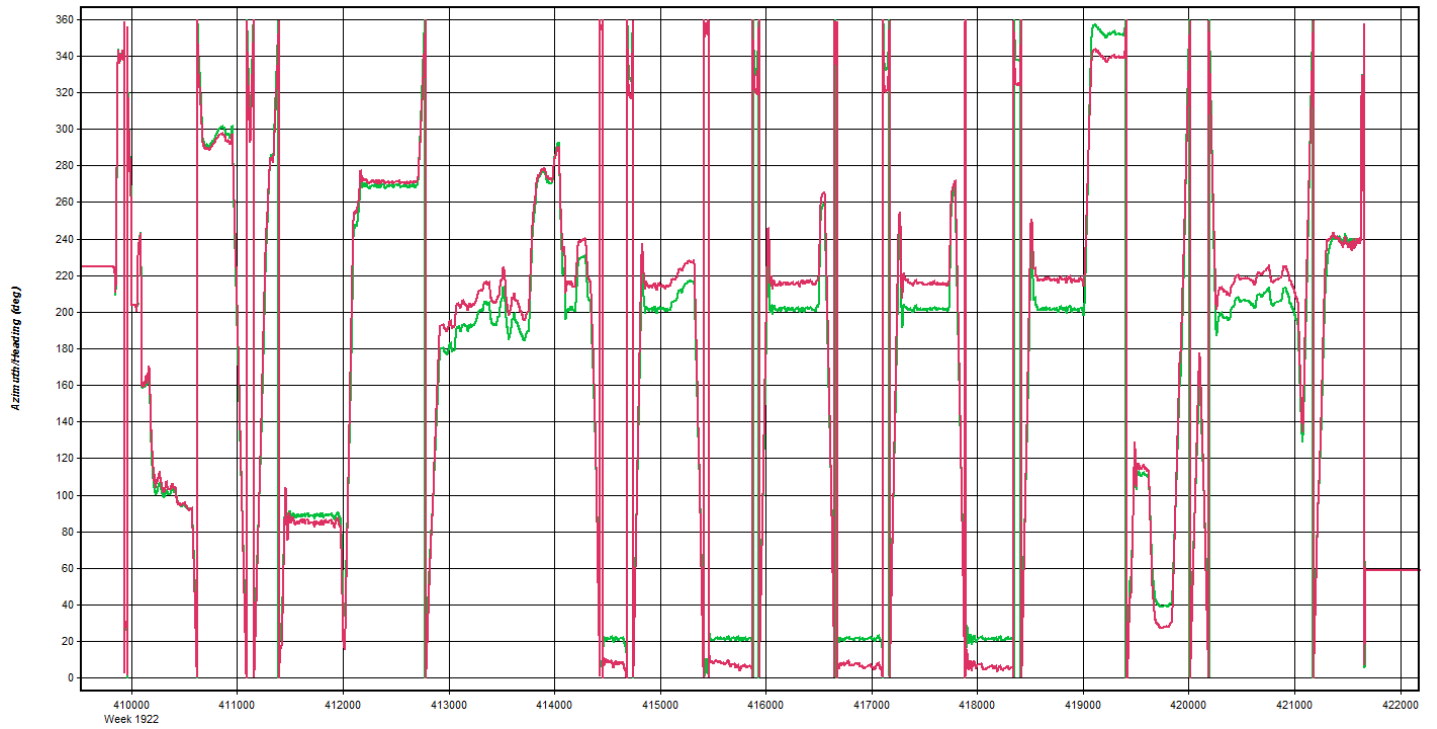
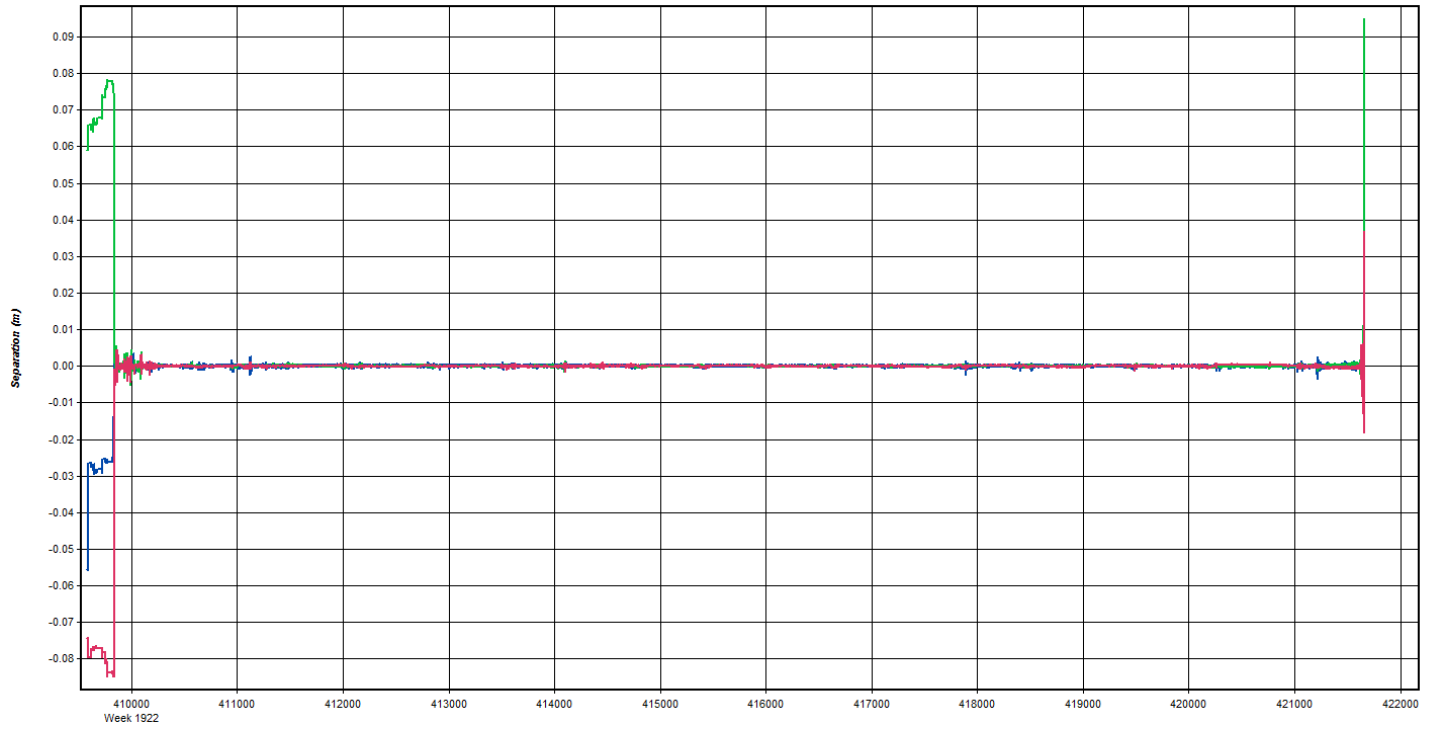

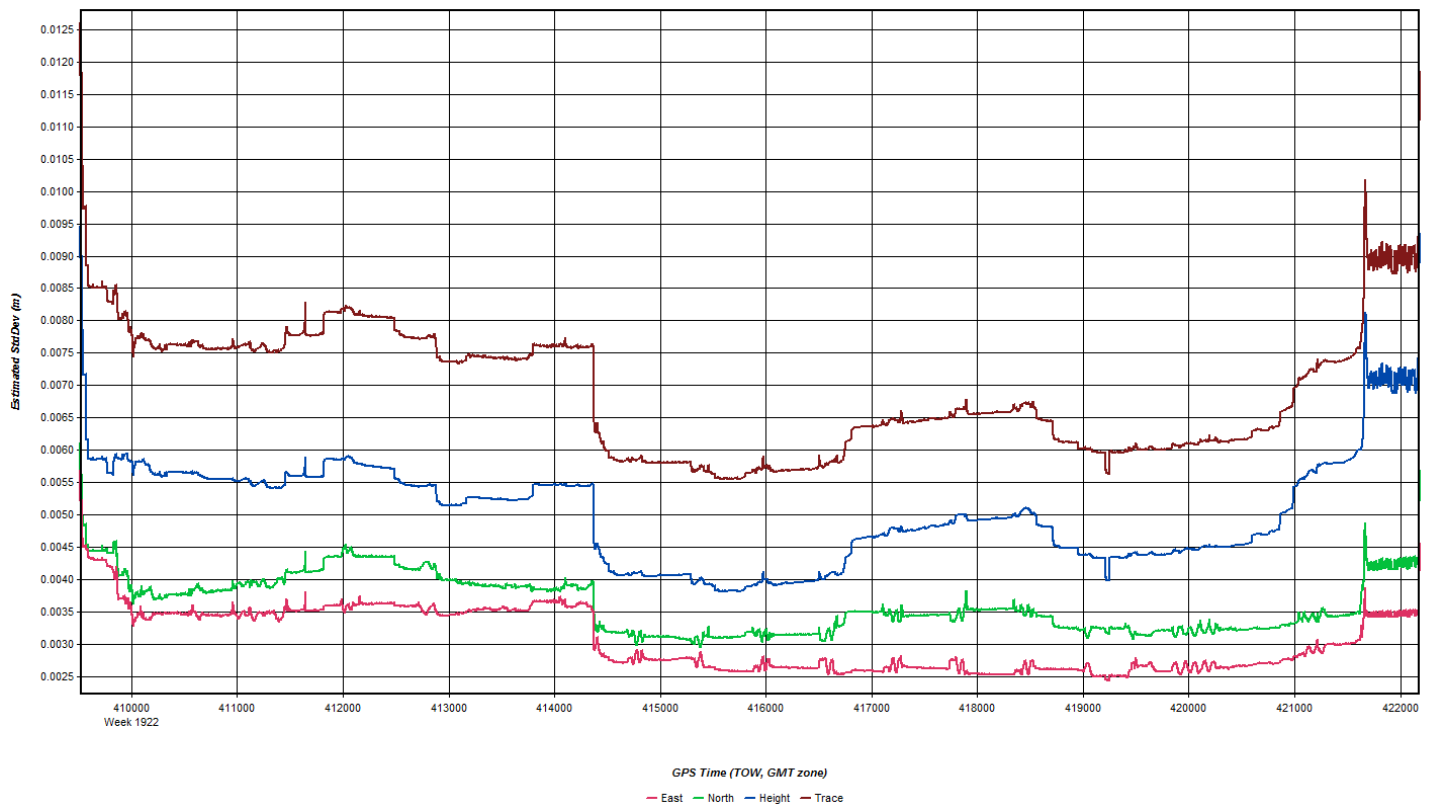
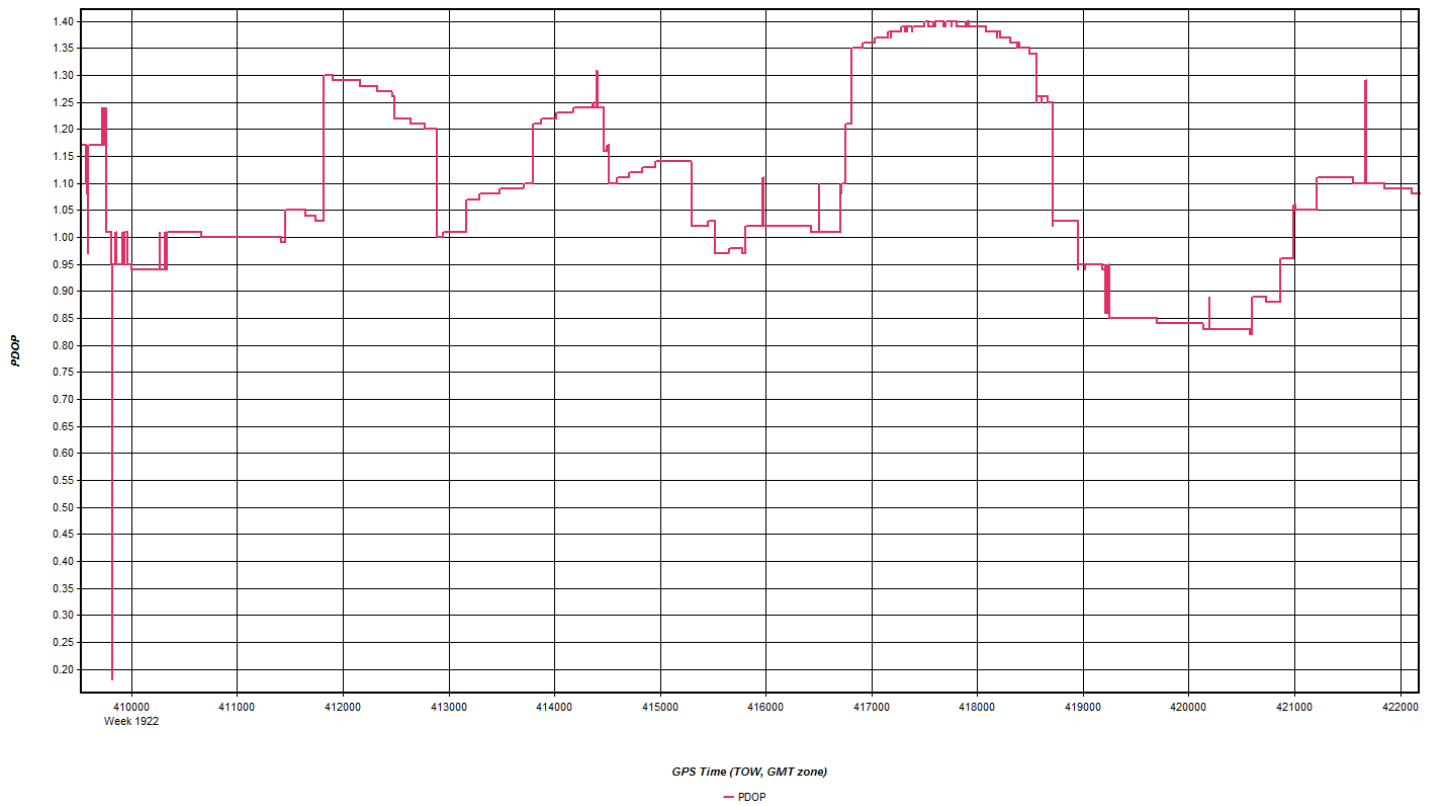

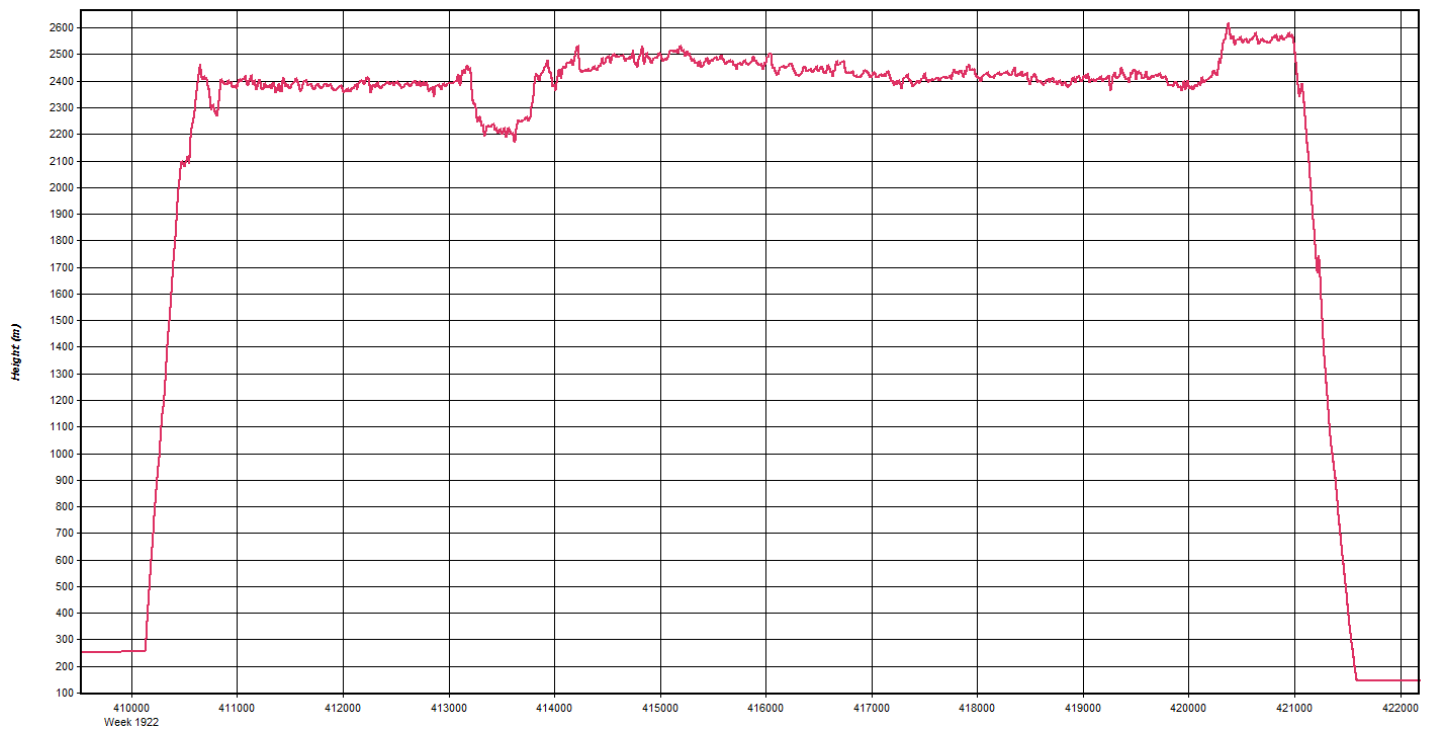
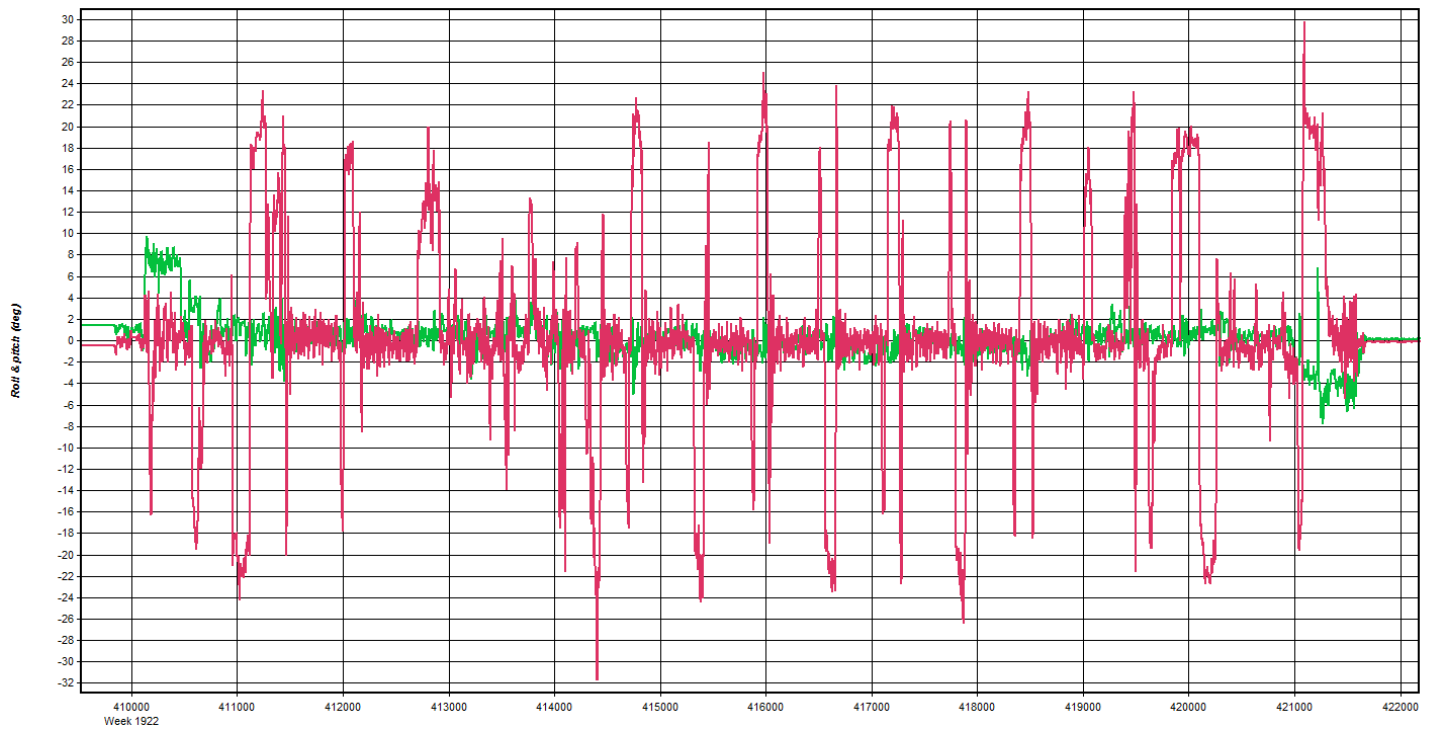

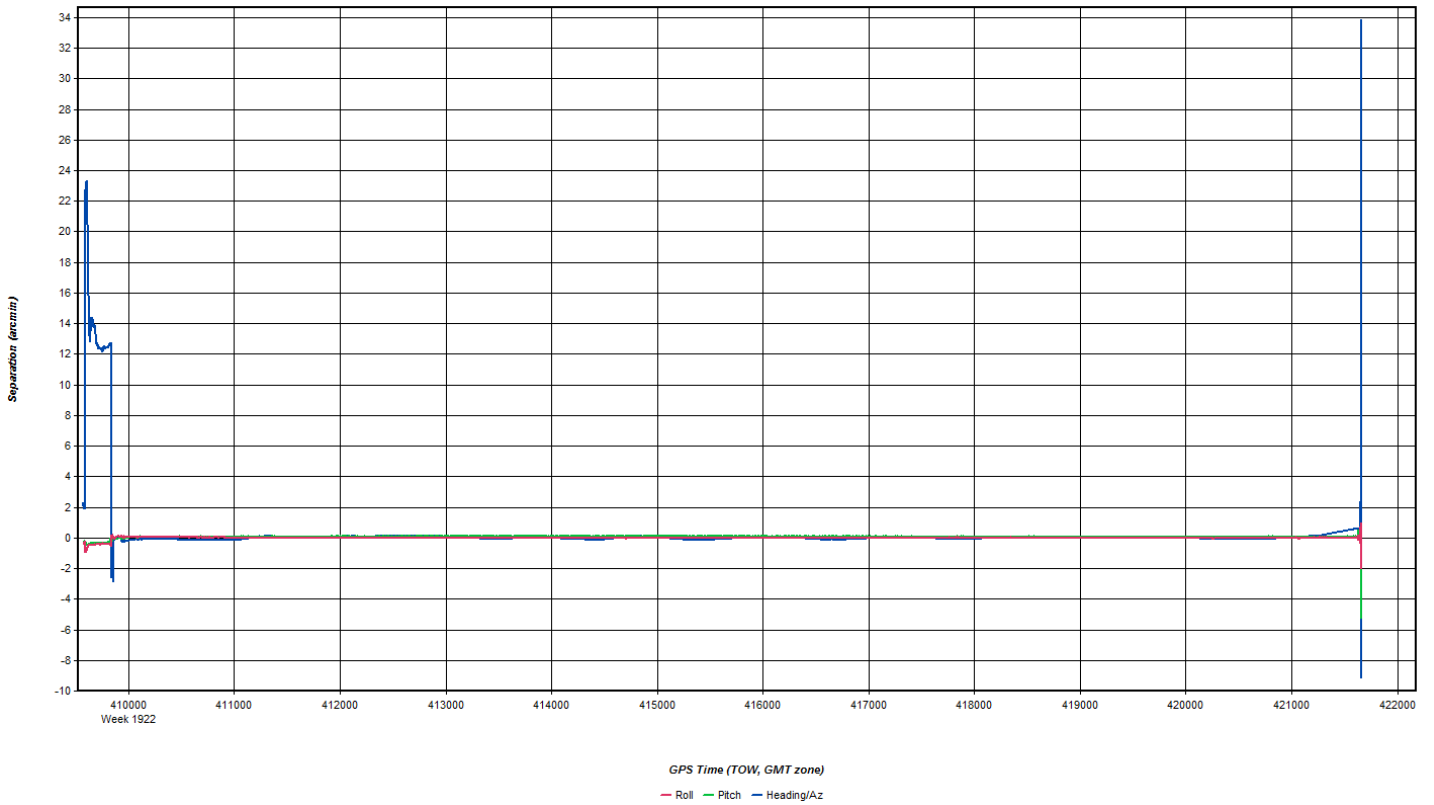
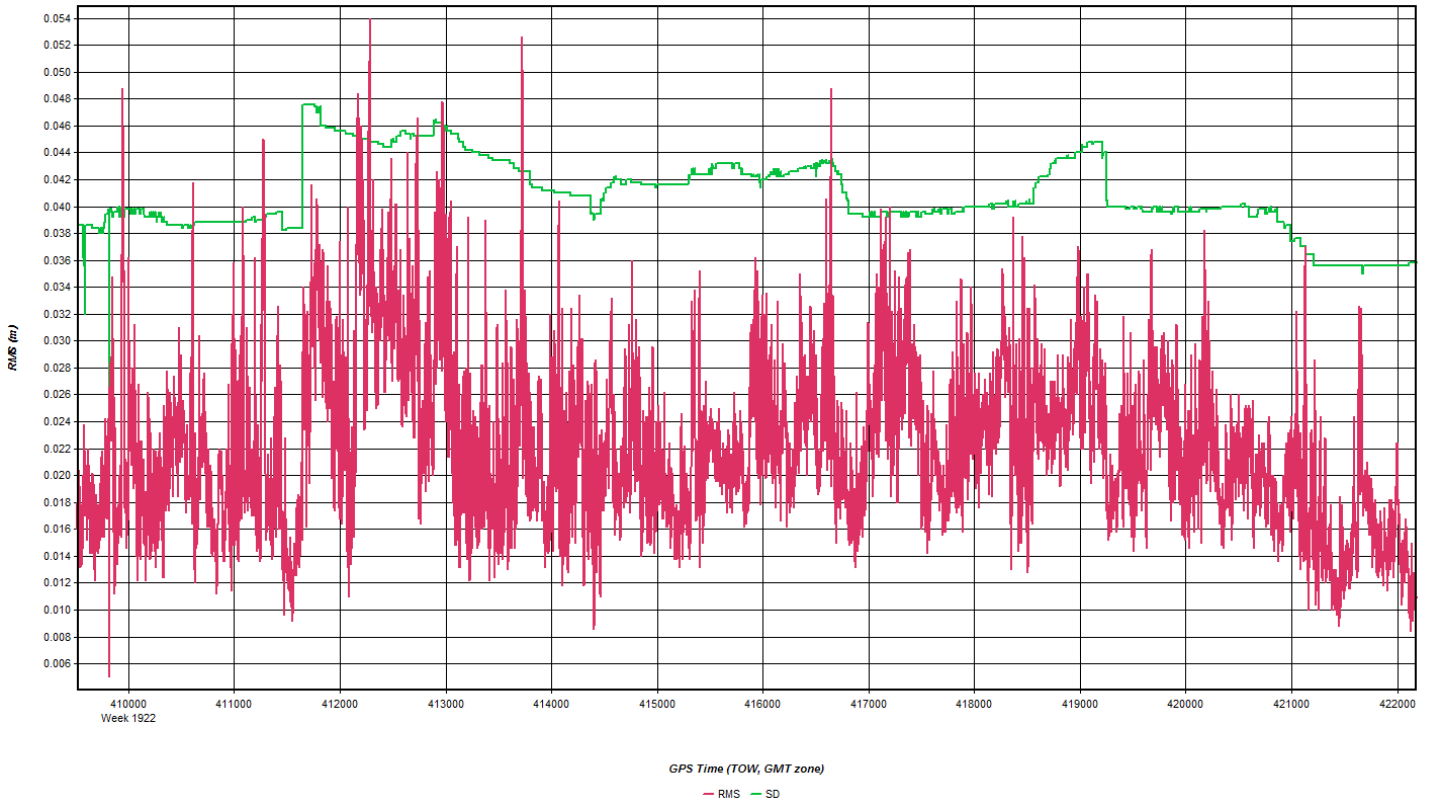

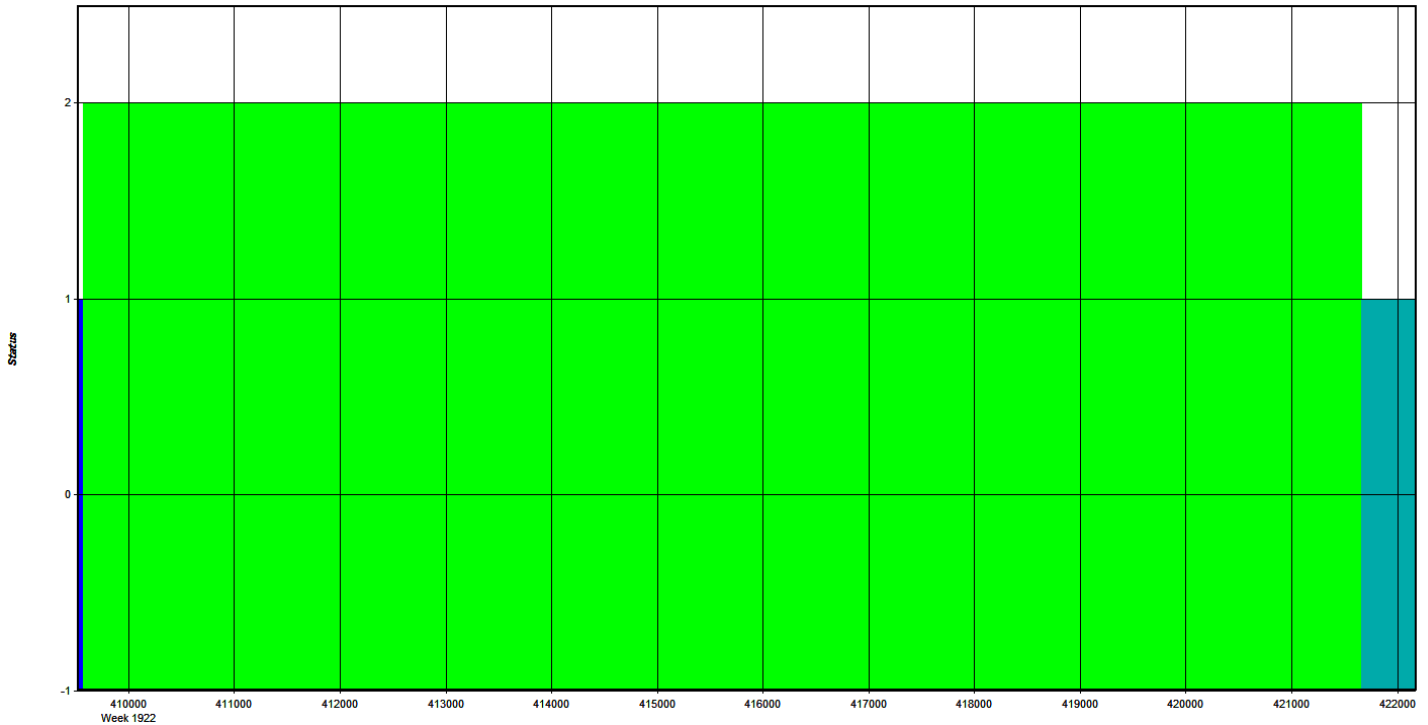

GPS Time (TOW, GMT zone)
 - Float - Forward Fixed - Reverse Fixed - Fixed (2 or more)

Coordinate/Antenna Settings

Master Remote

Base Station
 3: VTC1 Name: VTC1 Disabled
 File: E:\Proc\29178_VT_CT_River_Basin\20161110_A_B_29178_SN7

Coordinates
 Latitude: North 43 56 21.21809 Compute from PPP
 Longitude: West 72 36 12.56537 Enter Grid Values
 Ellipsoidal height: 405.144 m Enter MSL Height
 Datum: WGS84 Datum Options
 Select From Favorites Add To Favorites Use Average Position

Antenna Height
 From station file: TRM55971.00, NONE View STA File
 Antenna profile: TRM55971.00 Info
 Measured height: 0.000 m
 ARP to L1 offset: 0.067 m
 Applied height: 0.067 m
 Measured to
 ARP
 L1 Phase Centre
 Compute From Slant

OK Cancel

Coordinate/Antenna Settings ? X

Master Remote

Base Station
 2: VTD7 Name: VTD7 Disabled
 File: E:\Proc\29178_VT_CT_River_Basin\20161110_A_B_29178_SN7

Coordinates
 Latitude: North 44 23 52.31066 Compute from PPP
 Longitude: West 72 01 32.39267 Enter Grid Values
 Ellipsoidal height: 166.528 m Enter MSL Height
 Datum: WGS84 Datum Options
 Select From Favorites Add To Favorites Use Average Position

Antenna Height
 From station file: TRM55971.00, NONE View STA File
 Antenna profile: TRM55971.00 Info
 Measured height: 0.000 m
 ARP to L1 offset: 0.067 m
 Applied height: 0.067 m
 Measured to
 ARP
 L1 Phase Centre
 Compute From Slant

OK Cancel

Coordinate/Antenna Settings ? X

Master Remote

Base Station
 1: VTIP Name: VTIP Disabled
 File: E:\Proc\29178_VT_CT_River_Basin\20161110_A_B_29178_SN7

Coordinates
 Latitude: North 44 49 12.18043 Compute from PPP
 Longitude: West 71 53 25.83872 Enter Grid Values
 Ellipsoidal height: 341.732 m Enter MSL Height
 Datum: WGS84 Datum Options
 Select From Favorites Add To Favorites Use Average Position

Antenna Height
 From station file: TRM55971.00, NONE View STA File
 Antenna profile: TRM55971.00 Info
 Measured height: 0.000 m
 ARP to L1 offset: 0.067 m
 Applied height: 0.067 m
 Measured to
 ARP
 L1 Phase Centre
 Compute From Slant

OK Cancel

Flight Log

Quantum Spatial
Project: Airborne LiDAR Data Collection Log Sheet :: Quantum Spatial, Inc
 Date: 10/10/16
 Lift: A (B) C D E Pg. 1 of 1

Project: WSS WINDSOR Co Proj #: 29178 Flight Mgmt File:
 Aircraft: 737M Begin Hobbs: 482.2 End Hobbs: 648.5 Total: 8.3 Pilot: J BARNHAM Co-Pilot: M MUST
 Dep Apt: EFK Dep Time (Local): 17:50 (Z): 17:50 Arr Apt: LEB Arr Time (Local): 18:01 (Z): 18:01 Tot Time Aloft: 3.5
 CORS: (Y) N Sta 1: VTIP Sta 2: VTD7 Flyovers: Y/N If Y, times: Sta1) 18:01 Sta2) 18:55
 GPS Unit: Y/N Sta 1: Sta 2: Flyovers: Y/N If Y, times: Sta1) Sta2)

Gd Temp	beg	°C	End:	°C	OAT beg:	°C	End:	°C	Altimeter begin:	end:	Storage Name/s
LIDAR	Type ALS70	Serial # 7178	Alt ANSL 7.8	Avg Terr Ht	Max Gdspd	Power	Pulse Rate	AVG Pt Spacing PPSM	beg GB 378	End GB 353	4
	FOV 40	Scan Freq 53	MPIA Y/N	Pulse Rate	280	100					

Line #	Hdg	Start (UTC)	End (UTC)	Gd Spd	PDOP/sts	GPS Altitude	Crab	Turb (0-1)	FLIGHT LINE NOTES - visibility, clouds, smoke, partial, etc.
4001	E	1818	1825	155	1.1/17	7.8			WIND 280° @ 35 kts
4002	W	1829	1838	134	1.0/18	7.9			WIND 280° @ 38 kts
4003	S	1841	1842	185	1.2/16	7.8			Crossflight
3064	201°	1902	1902	143	1.0/18	8.1			BLK 3 WIND 275° @ 41 kts
3065	21°	1908	1910	153	1.0/18	8.1			
3066	201°	1914	1917	151	1.0/19	8.1			
3067	21°	1924	1930	155	1.1/18	8.1			
3068	201°	1934	1941	149	1.1/18	8.0			
3069	21°	1944	1951	159	1.1/17	8.0			
3070	201°	1955	2002	158	1.1/17	8.0			
3071	21°	2005	2012	158	1.5/15	8.0			
3072	201°	2016	2022	149	1.2/17	7.8			
3198	111°	2031	2033	222	1.2/17	7.9			Crossflight

Total Proj Lines: Lines Flown: Lines Remain: Online Time: 2.25 Mob Time: 1 Notes:

BLK 4
BLK 3

Nov 12, 2016-A (N73TM, SN7178)

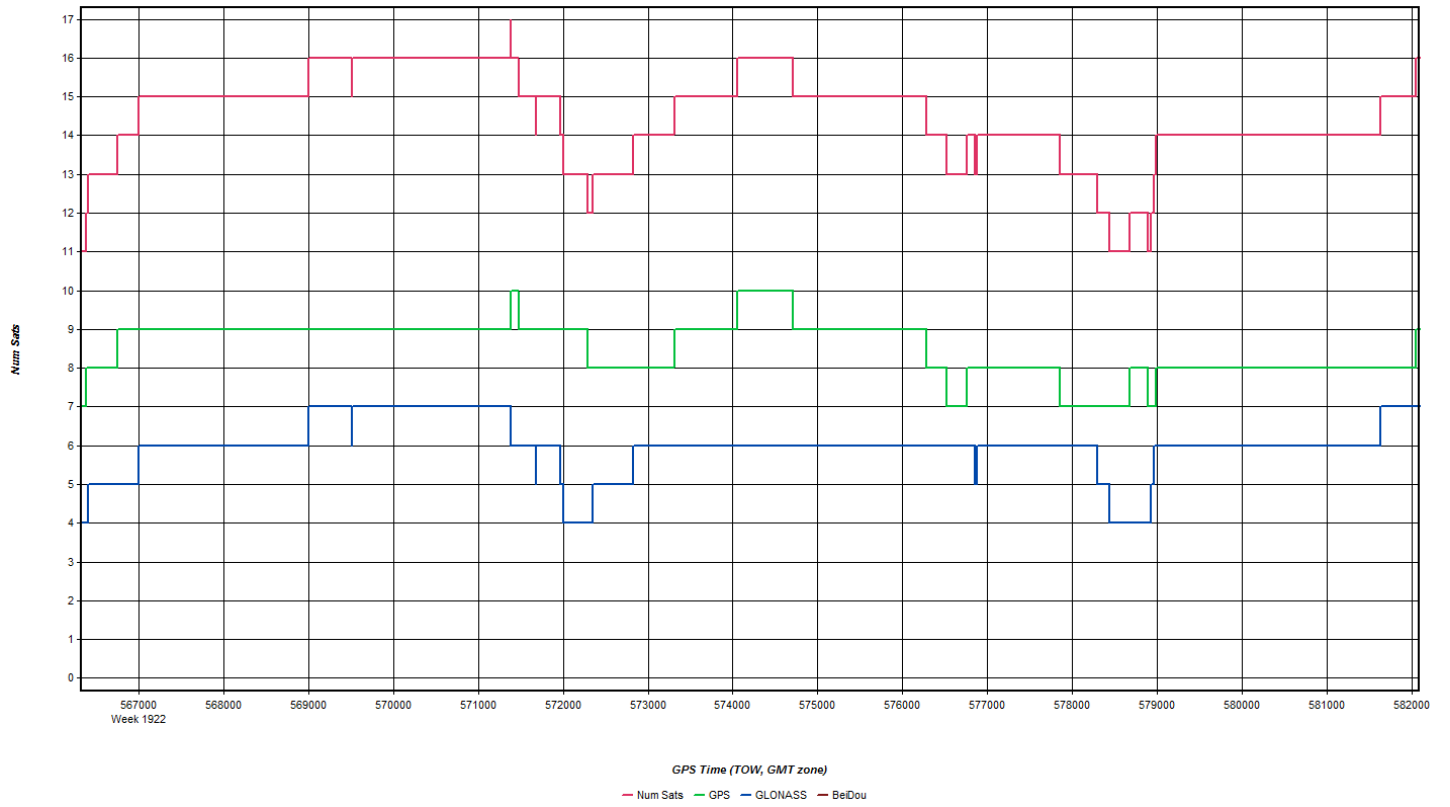
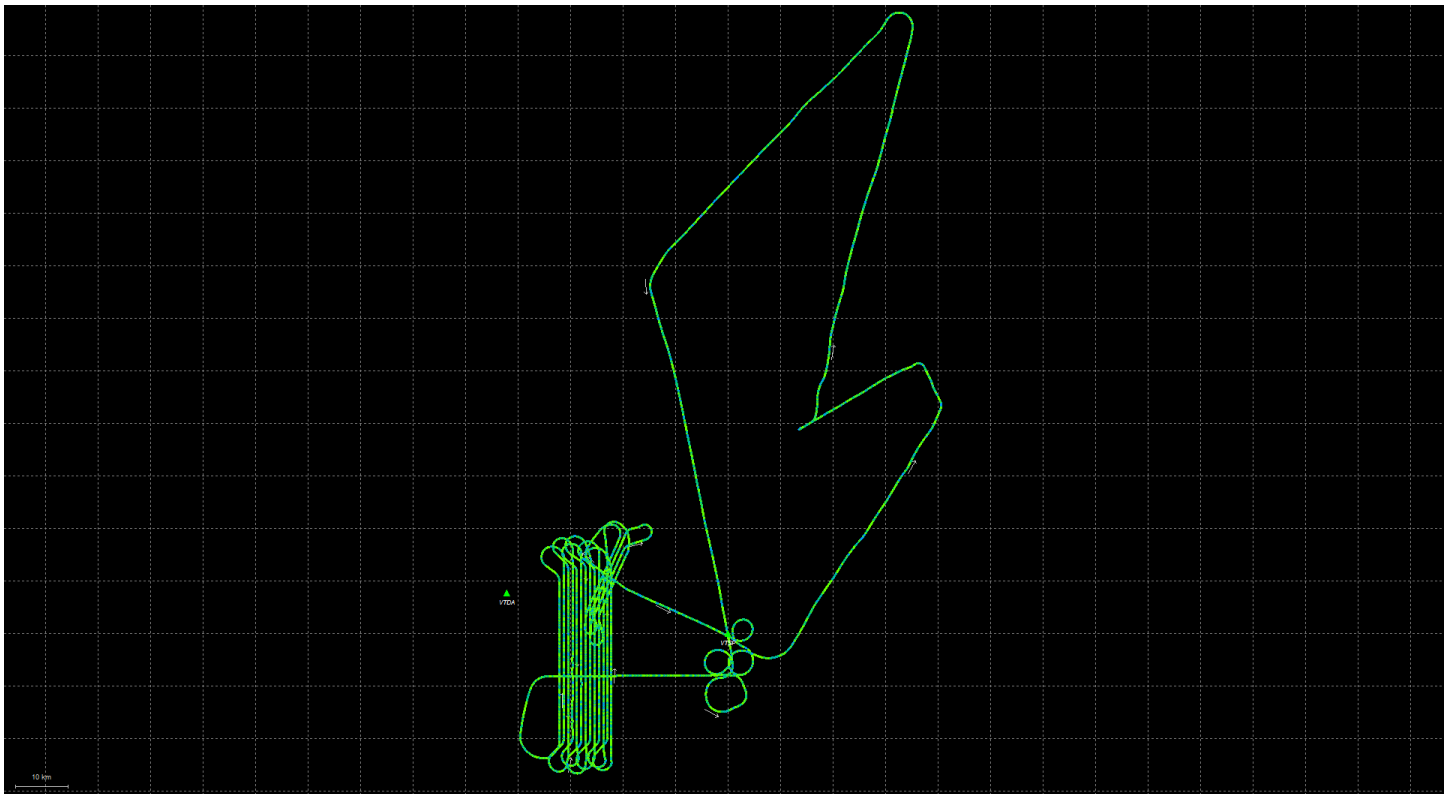

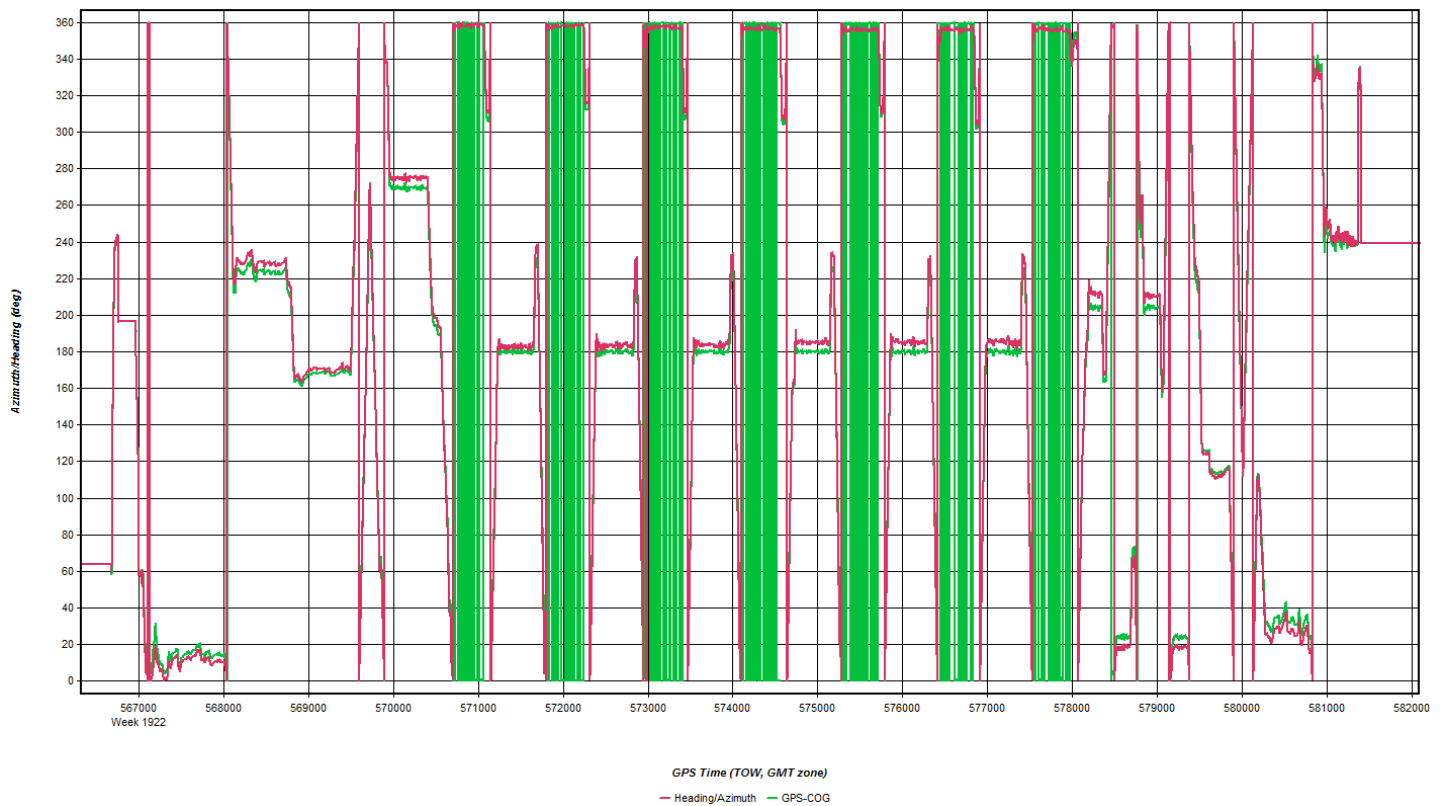
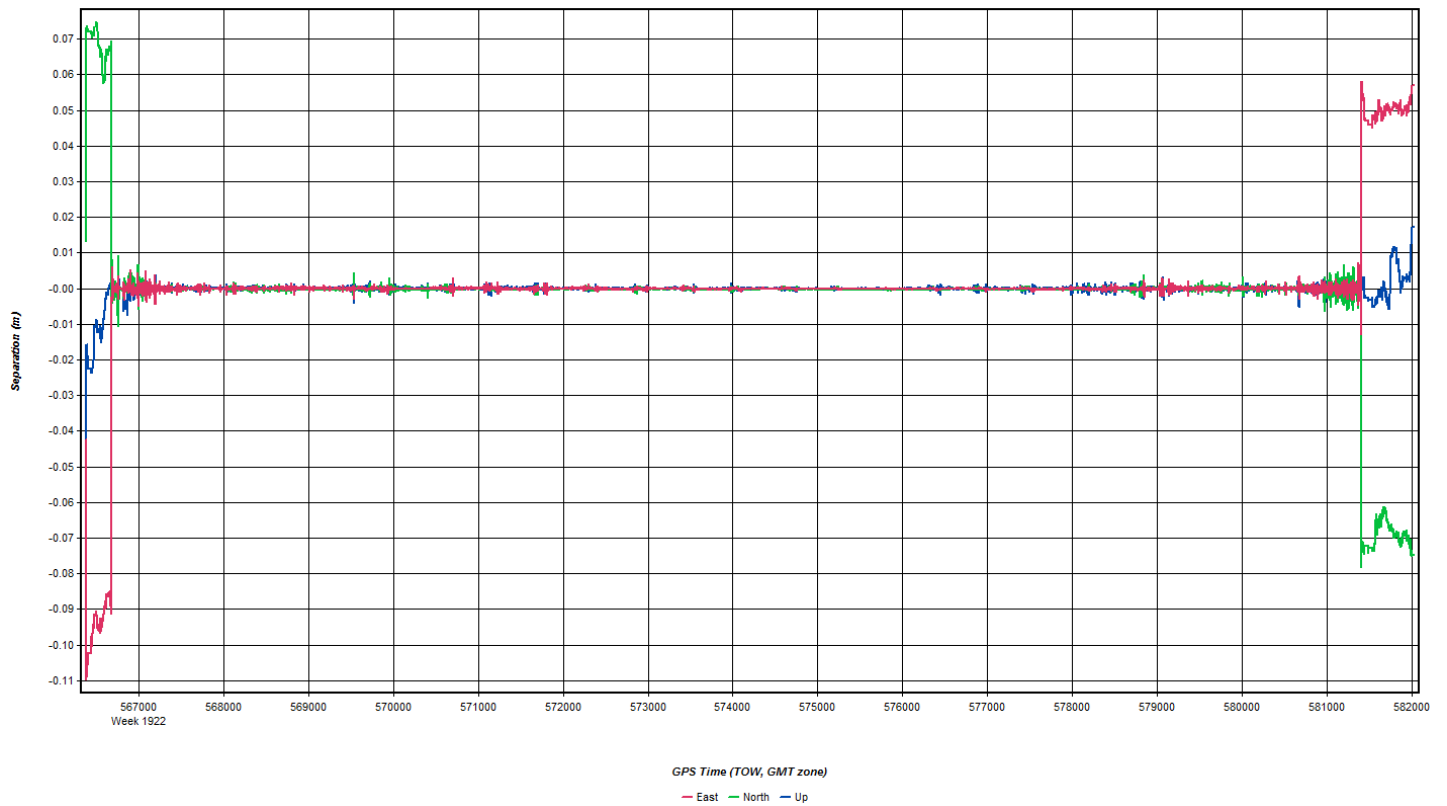

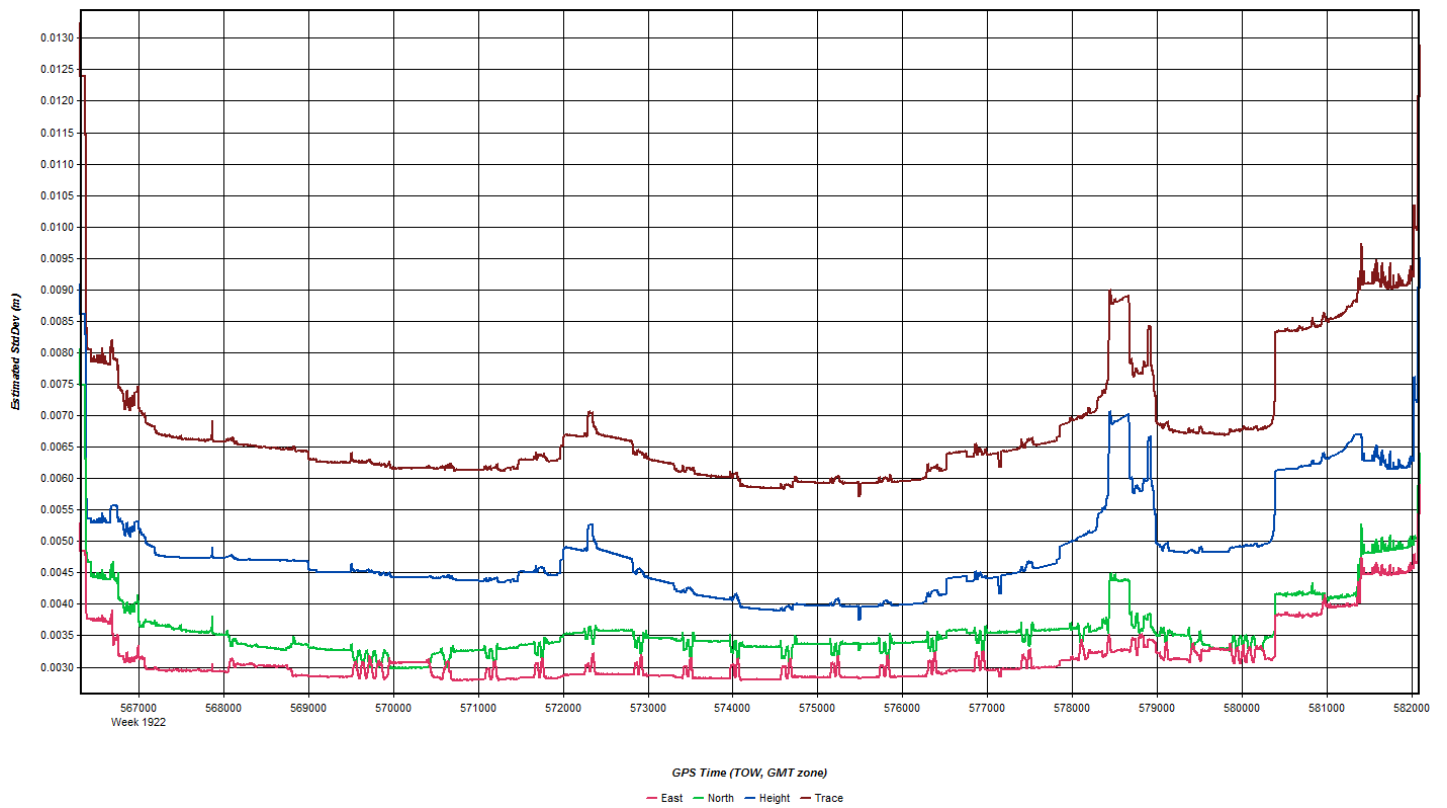
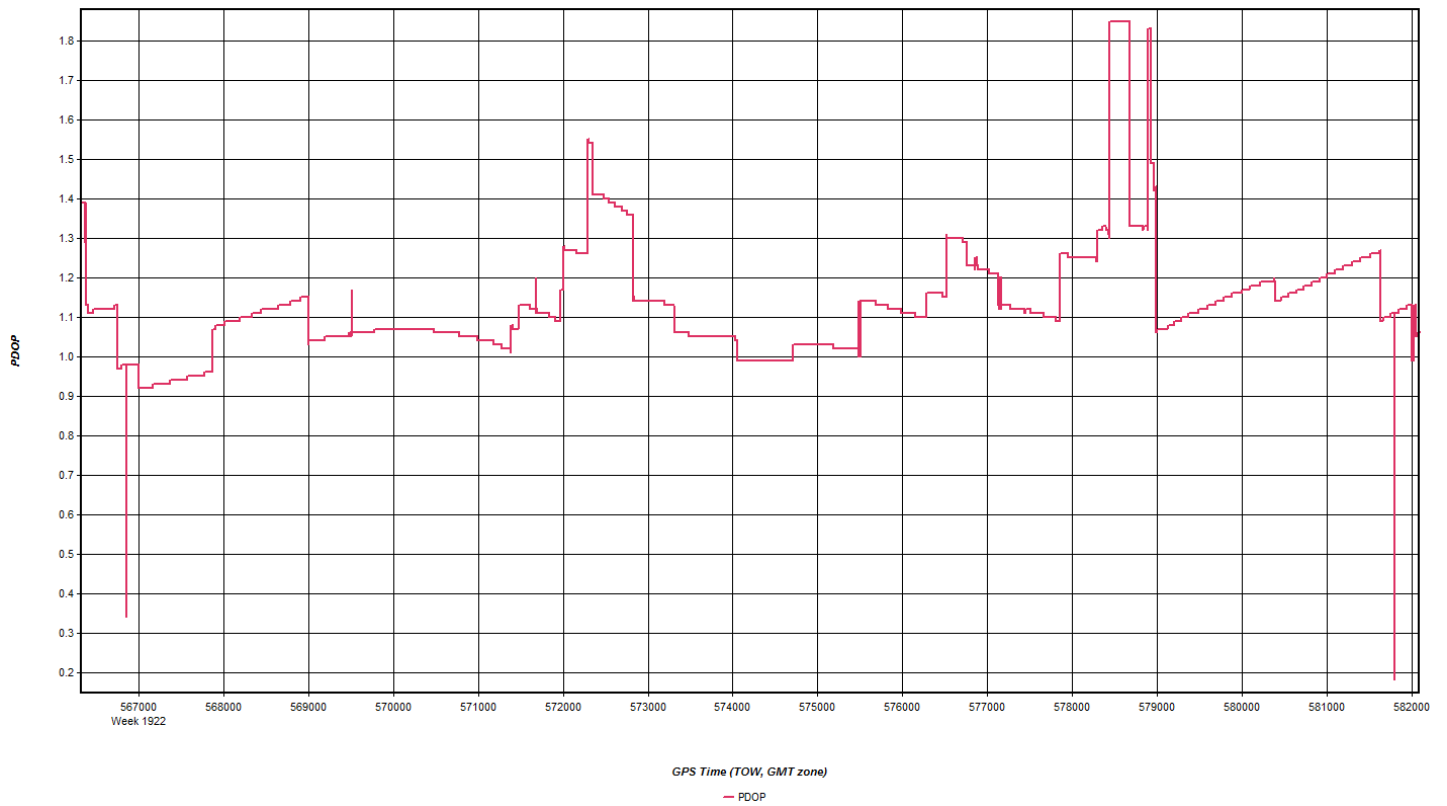

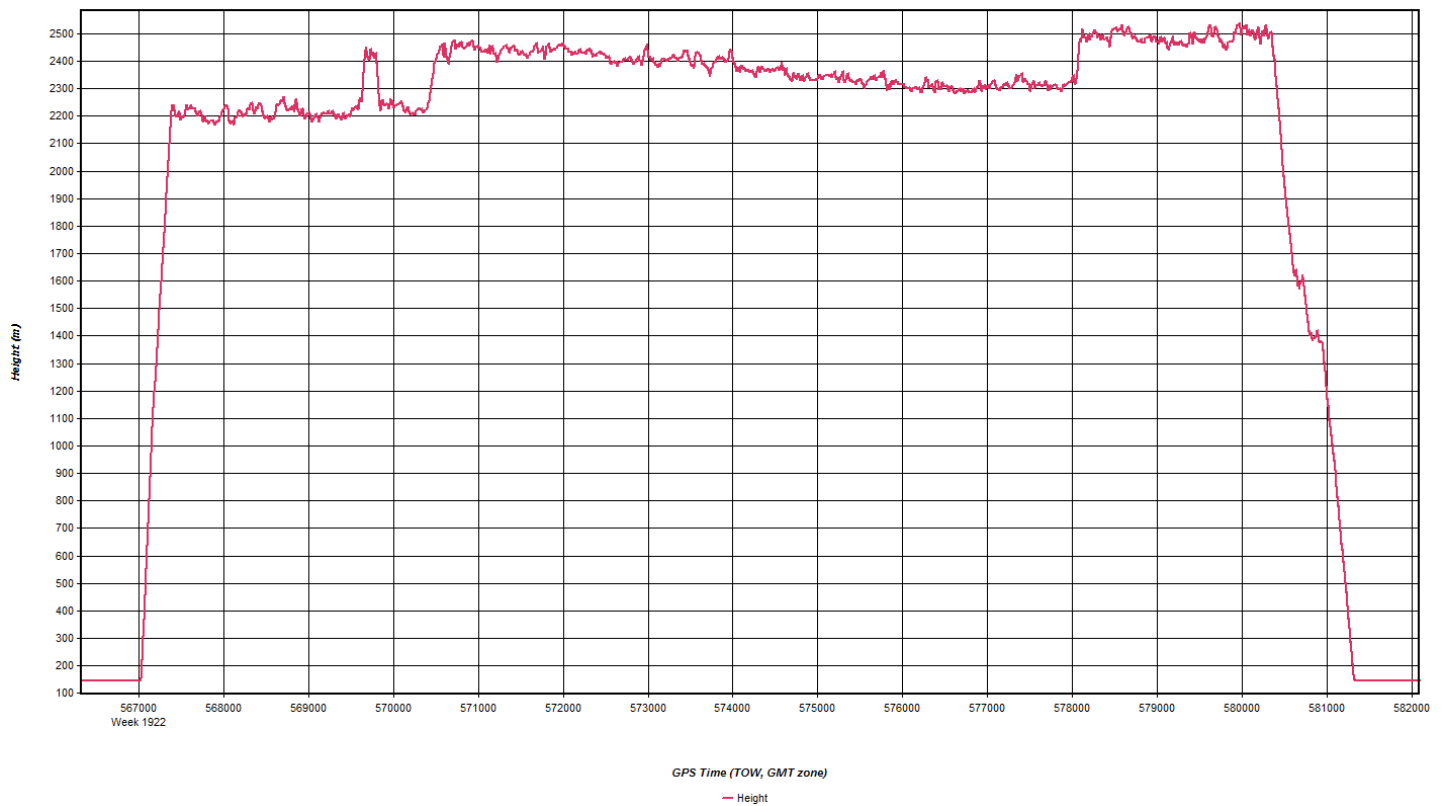
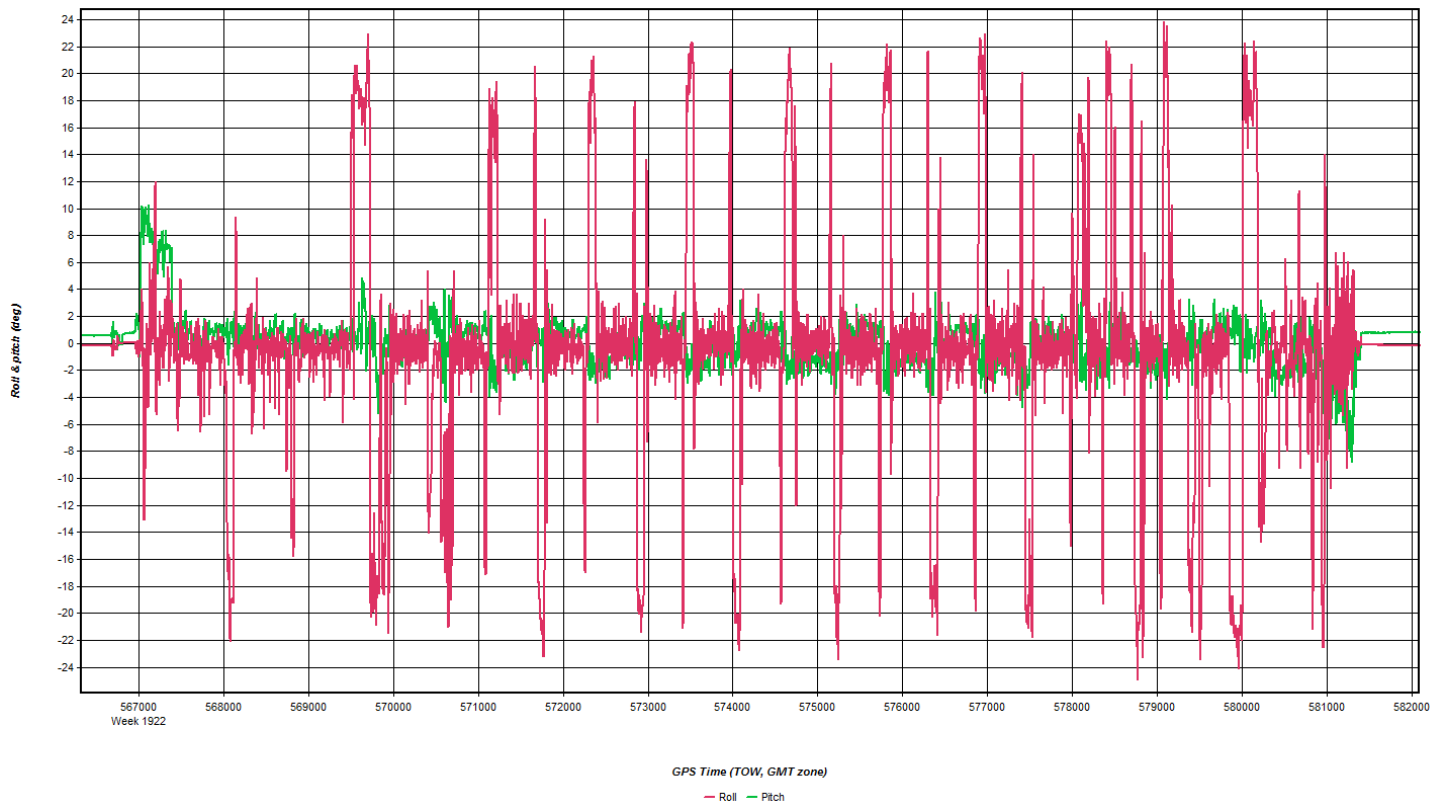

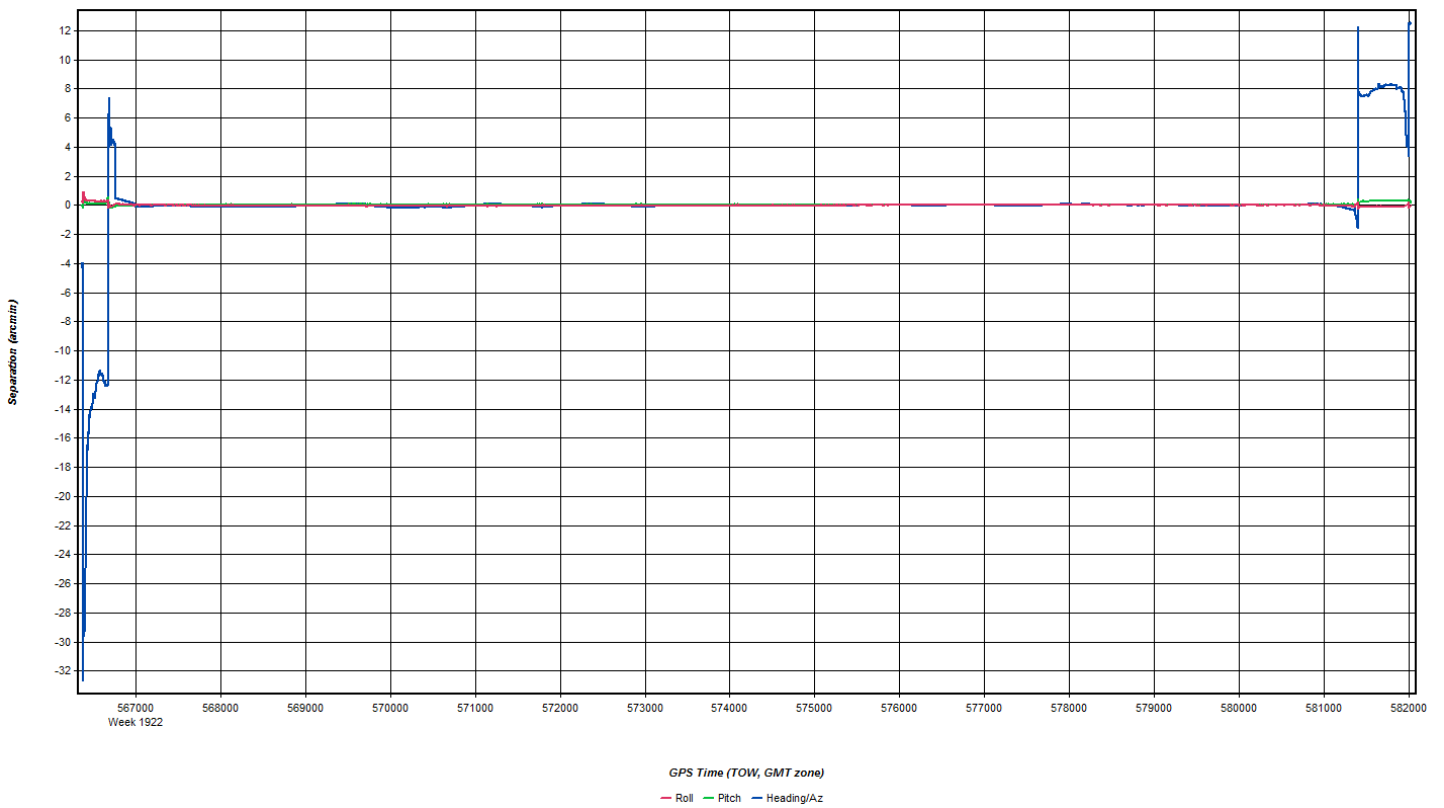

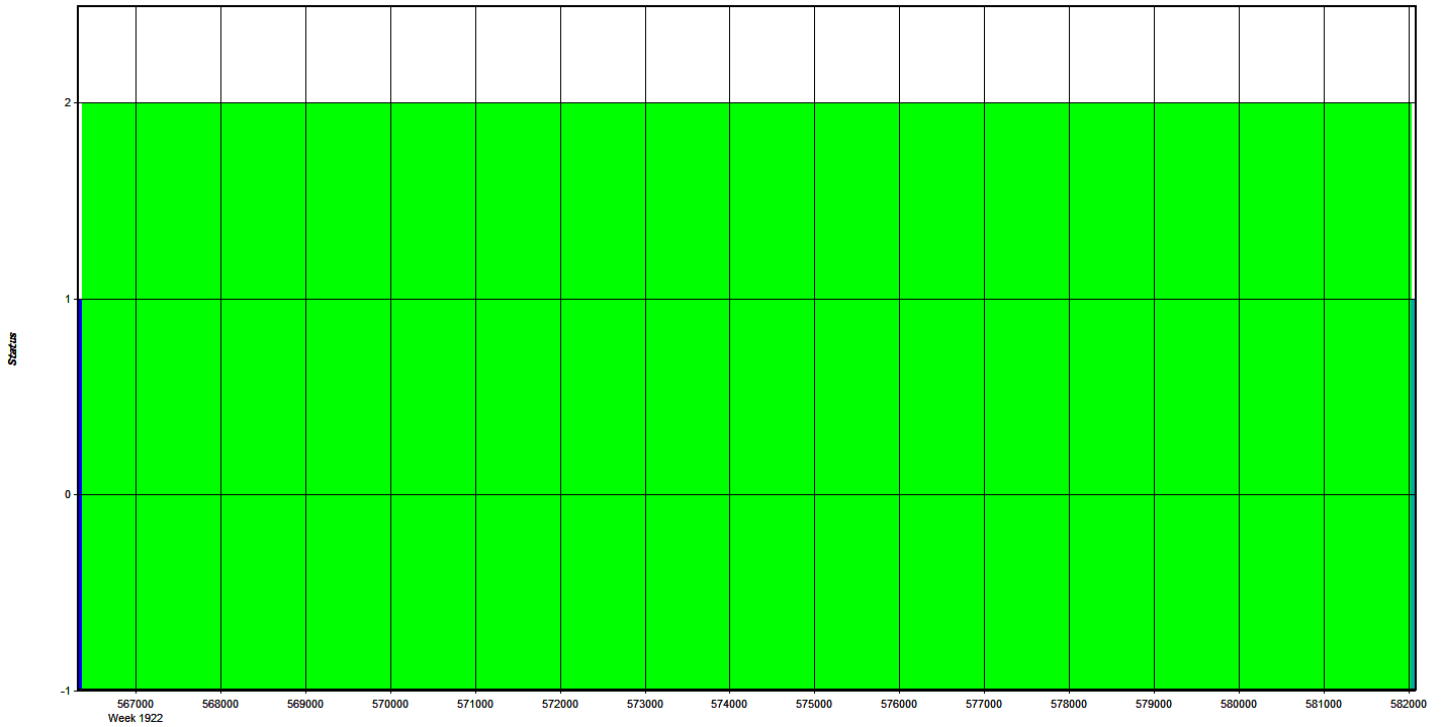

GPS Time (TOW, GMT zone)
 - Float - Forward Fixed - Reverse Fixed - Fixed (2 or more)

Coordinate/Antenna Settings

Master Remote

Base Station
 2: VTDA Name: VTDA Disabled
 File: E:\Proc\29178_VT_CT_River_Basin\From_M_Aust_11-15-16\201

Coordinates
 Latitude: North 43 20 59.81557 Compute from PPP
 Longitude: West 72 59 42.85115 Enter Grid Values
 Ellipsoidal height: 193.964 m Enter MSL Height
 Datum: WGS84 Datum Options
 Select From Favorites Add To Favorites Use Average Position

Antenna Height
 From station file: TRM55971.00, NONE View STA File
 Antenna profile: TRM55971.00 Info
 Measured height: 0.000 m
 ARP to L1 offset: 0.067 m
 Applied height: 0.067 m
 Measured to:
 ARP
 L1 Phase Centre
 Compute From Slant

OK Cancel

Coordinate/Antenna Settings

Master Remote

Base Station
1: VTSP Name: VTSP Disabled
File: E:\Proc\29178_VT_CT_River_Basin\From_M_Aust_11-15-16\201

Coordinates
Latitude: North 43 16 53.24114 Compute from PPP
Longitude: West 72 28 39.23841 Enter Grid Values
Ellipsoidal height: 156.441 m Enter MSL Height
Datum: WGS84 Datum Options
Select From Favorites Add To Favorites Use Average Position

Antenna Height
From station file: TRM55971.00, NONE View STA File
Antenna profile: TRM55971.00 Info
Measured height: 0.000 m
ARP to L1 offset: 0.067 m
Applied height: 0.067 m
Measured to:
 ARP
 L1 Phase Centre
Compute From Slant

OK Cancel

Flight Log

Airborne LiDAR Data Collection Log Sheet :: Quantum Spatial, Inc

Date: 11-12-16
City: C D E Pg. 1 of 1

Project: 4565 CRIVER Proj #: 29187 Flight Mgmt File:
 Aircraft: 737M Begin Hobbs: 6485.5 End Hobbs: 6489.3 Total: 3.8 Pilot: J. Bayliss Co-Pilot: Tech: M. Alst
 Dep Apt: LEB Dep Time (Lcl): 8:30 (Z): 13:30 Arr Apt: LEB Arr Time (Local): 12:30 (Z): 1730 Tot Time Aloft: 4
 CORS: GN Sta 1: VTSP Sta 2: Flyovers: Y/N If Y, times: Sta1) 411, 1703 Sta2)
 GPS Unit: Y/N Sta 1: Flyovers: Y/N If Y, times: Sta1) Sta2)

Gd Temp beg: 1 °C End: 6 °C OAT beg: 0 °C End: 30.23 °C	Alt AMSL 8.0	Avg Terr Ht	Max Gdepd	end: 30.18	Storage Name/e
LIDAR Type 42570	Alt AGL 7.3	Pulse Rate 260	Power 100		4
FOV 40	Scan Freq 53	MPIA 1/N			

Line #	Hdg	Start (UTC)	End (UTC)	Gd Spd	PDOP/sats	GPS Altitude	Crab	Turb (0-4)	FLIGHT LINE NOTES - visibility, clouds, smoke, partial, etc
1098	W	1420	1426	151	1.3/16	7.3			
1001	N	1431	1437	153	1.2/17	8.0			CROSSFLIGHT
1002	S	1440	1447	150	1.1/17	8.0			
1003	N	1450	1457	152	1.0/18	8.0			
1004	S	1500	1506	151	1.0/18	8.0			
1005	N	1509	1516	152	1.1/17	7.9			
1006	S	1519	1525	160	1.1/17	7.9			
1007	N	1529	1535	152	1.2/16	7.8			
1008	S	1539	1545	162	1.2/16	7.7			
1009	N	1548	1555	149	1.2/16	7.6			
1010	S	1558	1604	155	1.2/16	7.5			
1011	N	1607	1614	154	1.1/16	7.6			
1012	S	1616	1622	156	1.0/17	7.6			
1013	N	1626	1632	155	1.2/16	7.6			
1059	204°	1636	1638	153	1.0/18	8.2			
1058	24°	1642	1644	155	0.9/19	8.2			
1057	204°	1647	1650	155	1.0/18	8.1			
1056	24°	1653	1655	156	1.1/16	8.1			

Total Proj Lines: 12001	125°	1558	1700	179	11.1/16	8.1	Online Time: 2.75	Notes: CROSSFLIGHT
Lines Flow:	Lines Remain:	Lines Flow:	Lines Remain:	Lines Flow:	Lines Remain:	Lines Flow:	Lines Remain:	Lines Flow:

Nov 12, 2016-B (N73TM, SN7178)

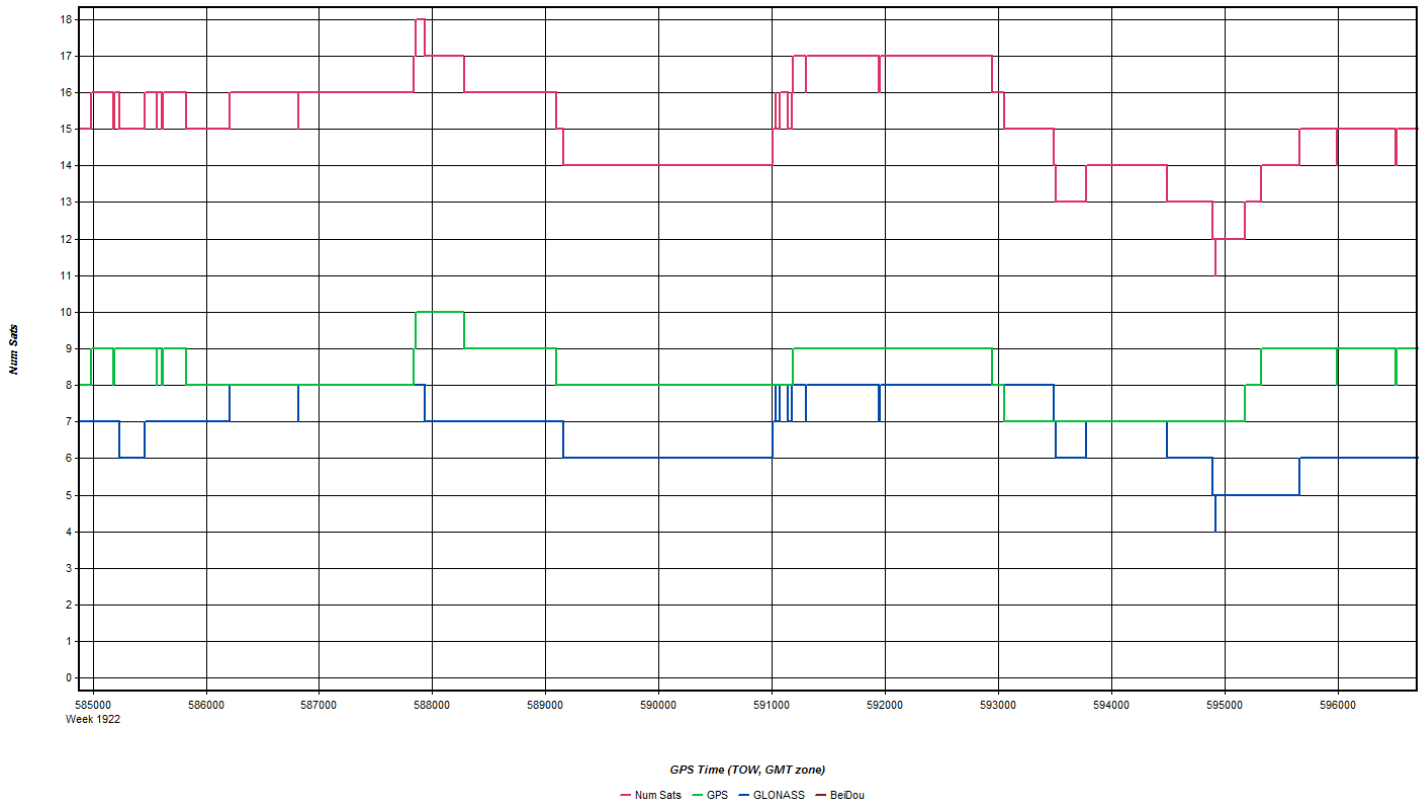
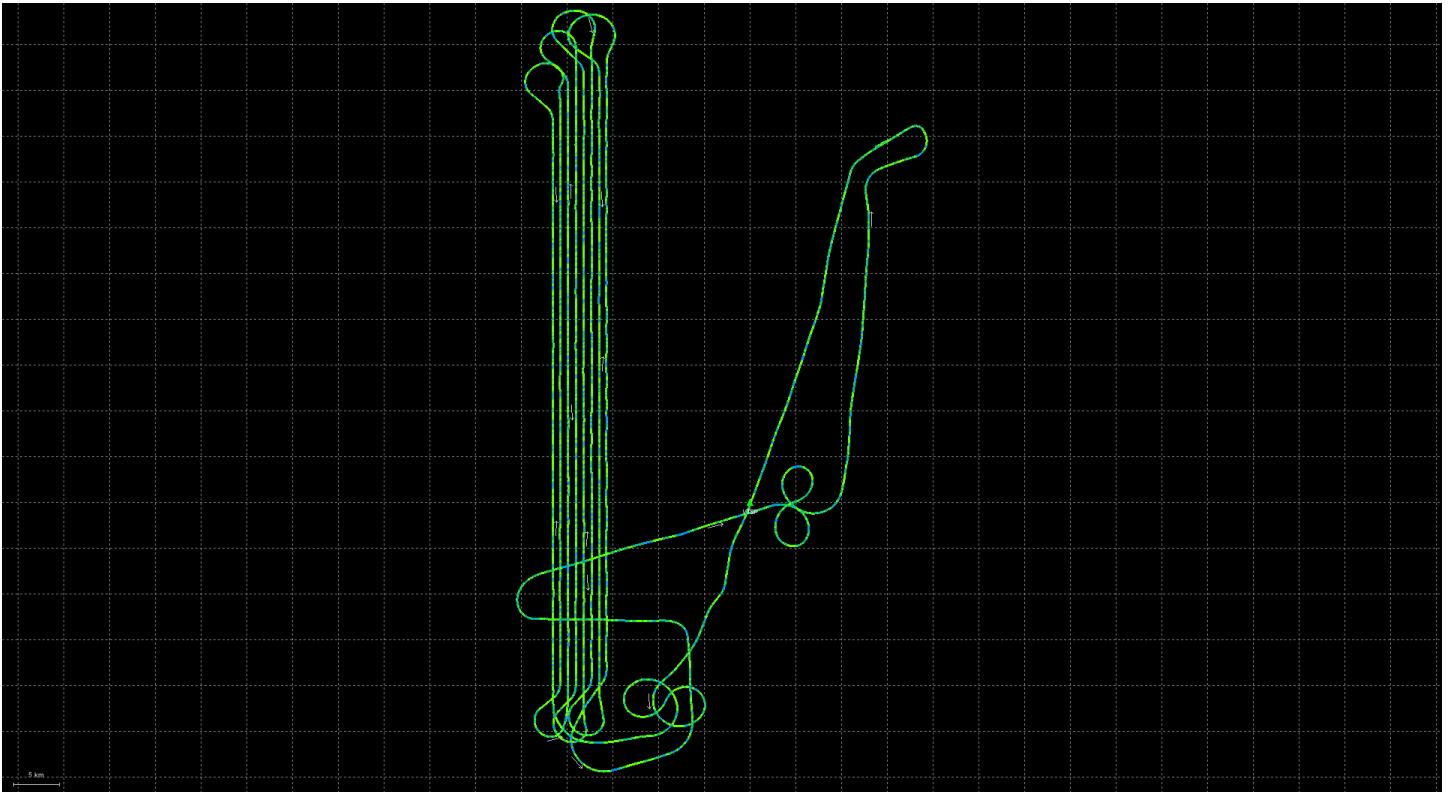

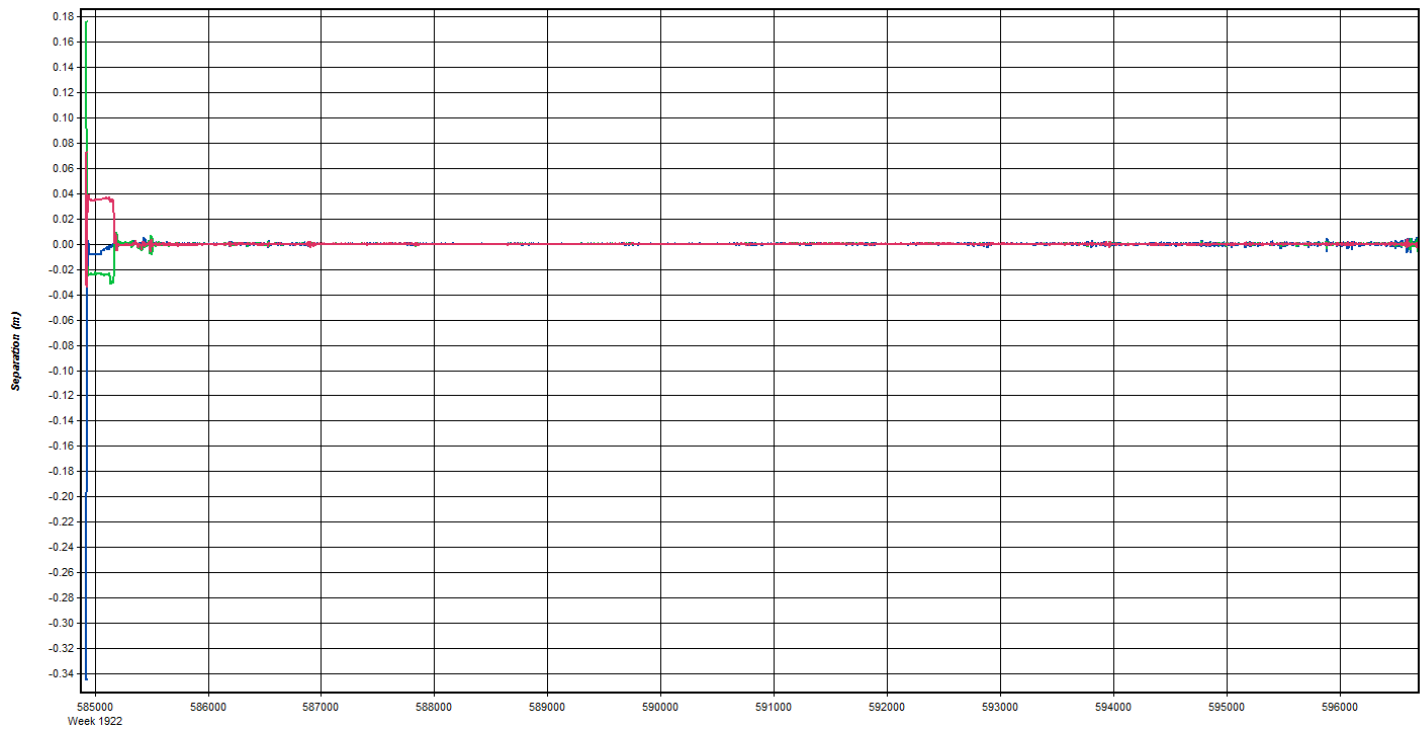

GPS Time (TOW, GMT zone)

— East — North — Up

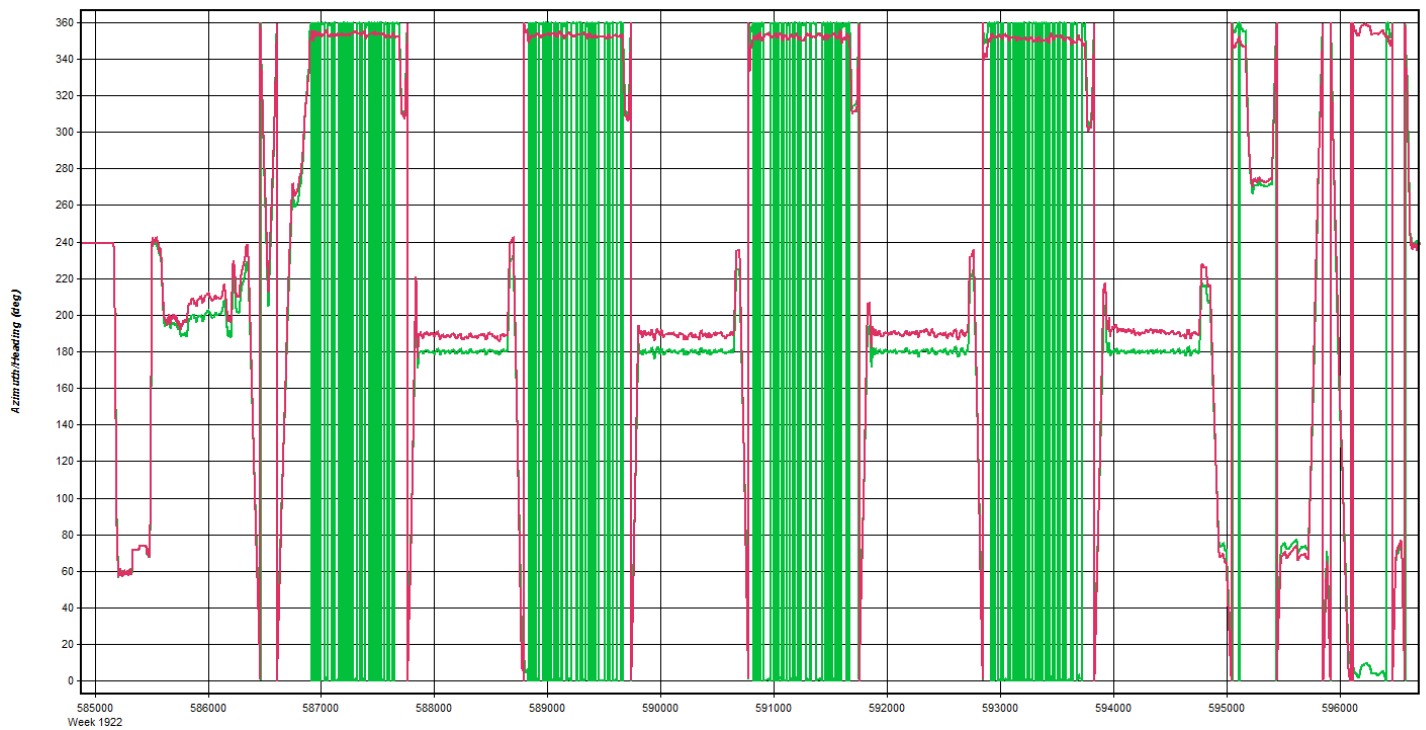

GPS Time (TOW, GMT zone)

— Heading/Azimuth — GPS-COG

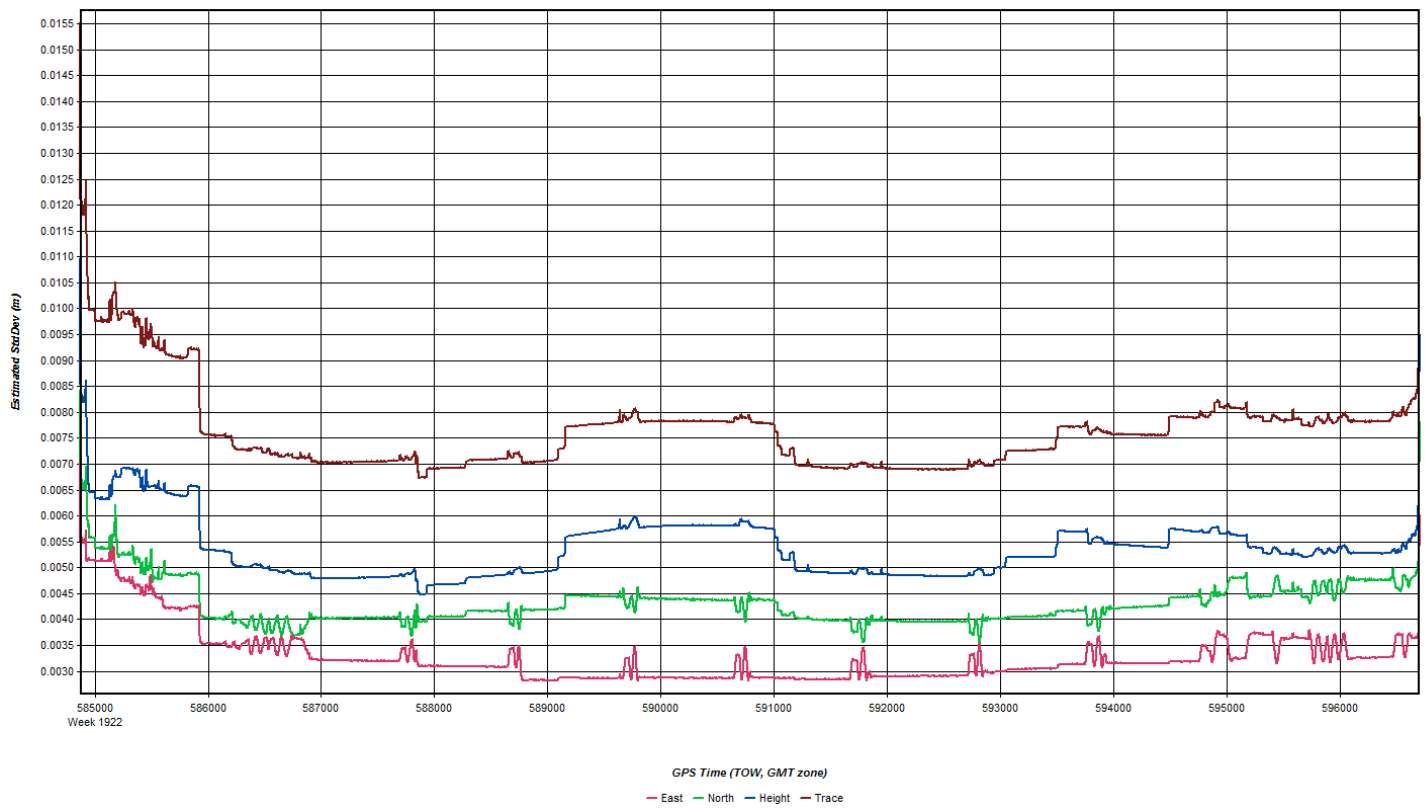
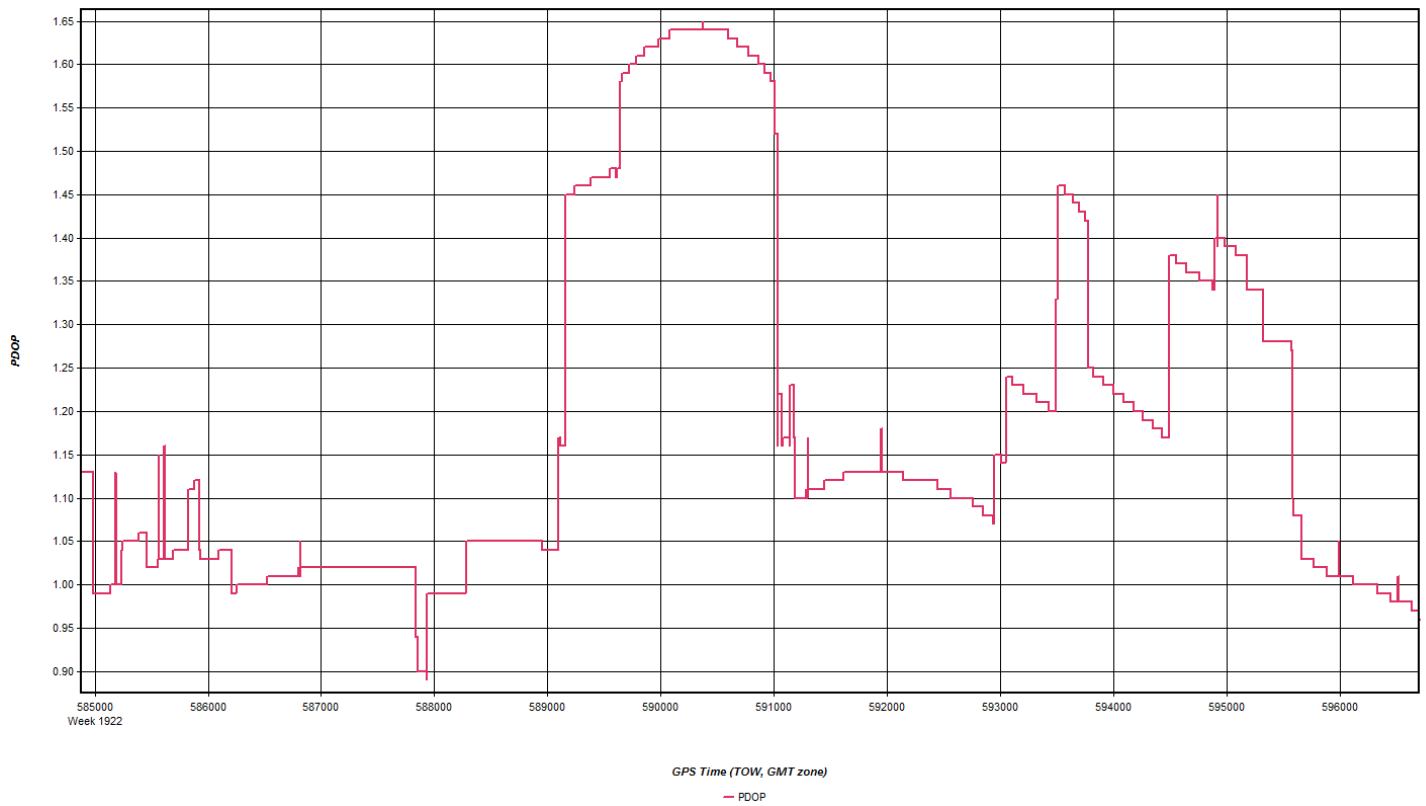

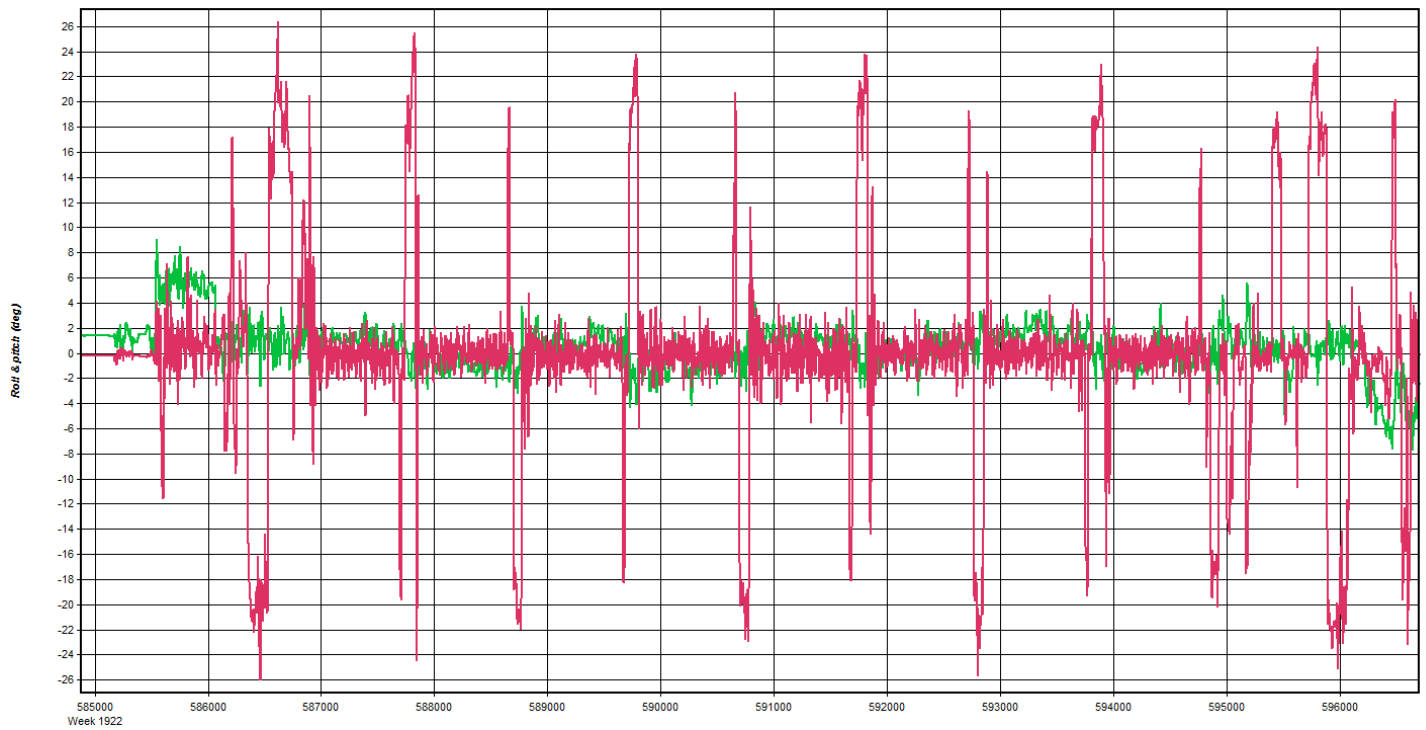

GPS Time (TOW, GMT zone)

— Roll — Pitch

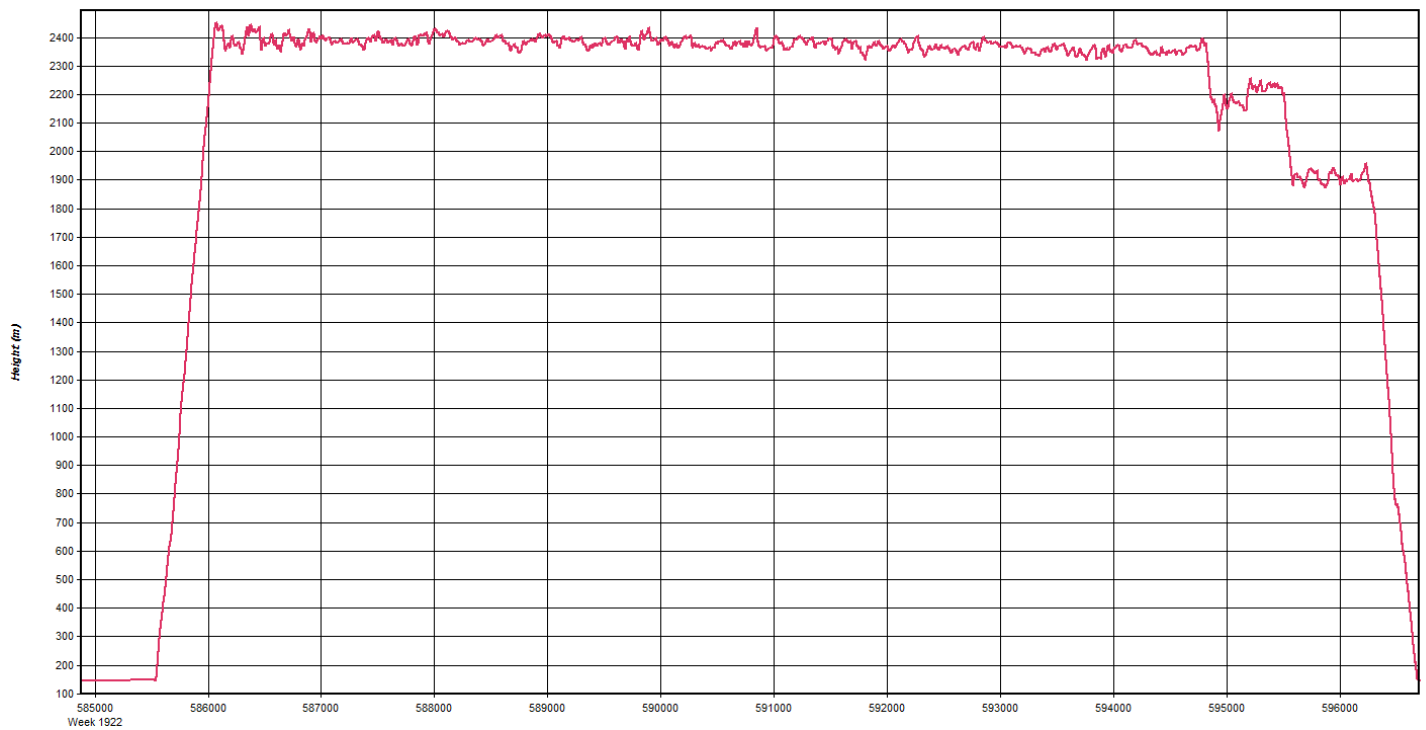

GPS Time (TOW, GMT zone)

— Height

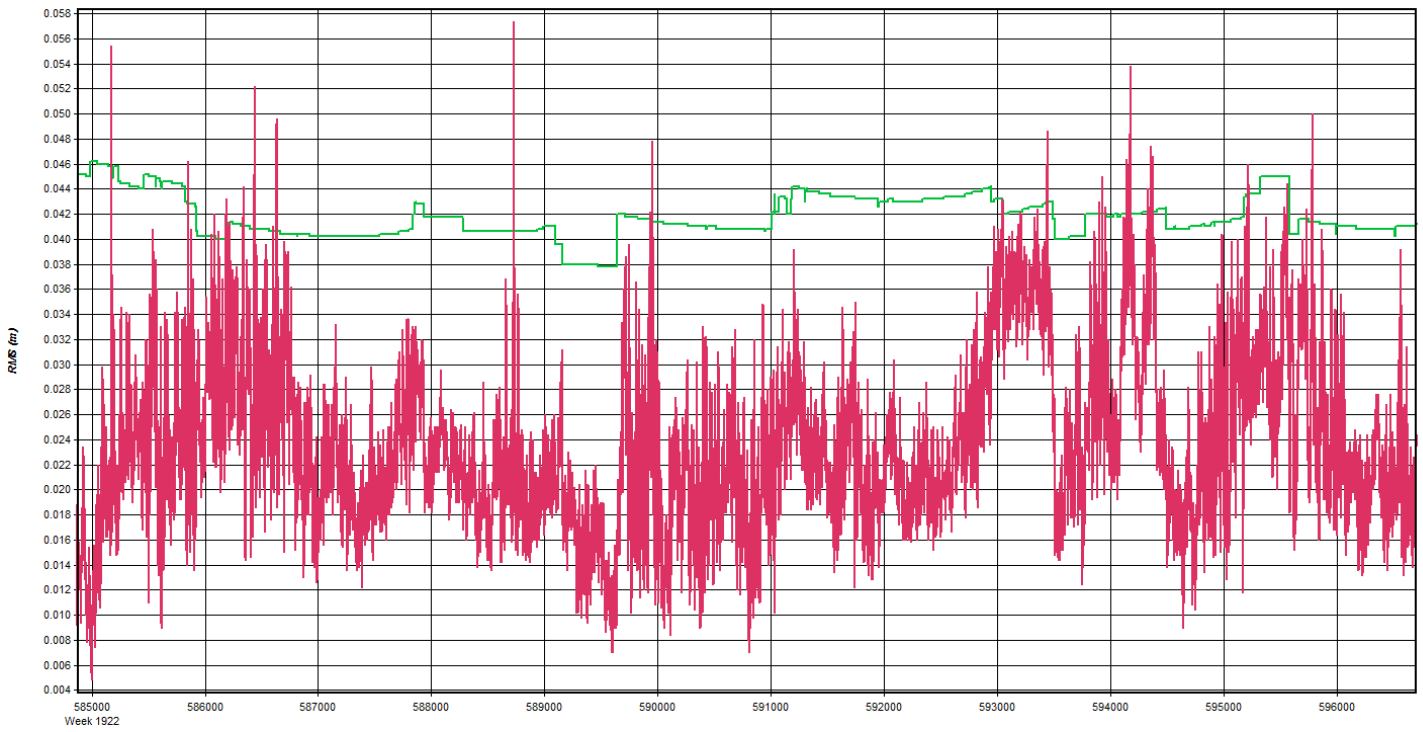

GPS Time (TOW, GMT zone)
— RMS — SD

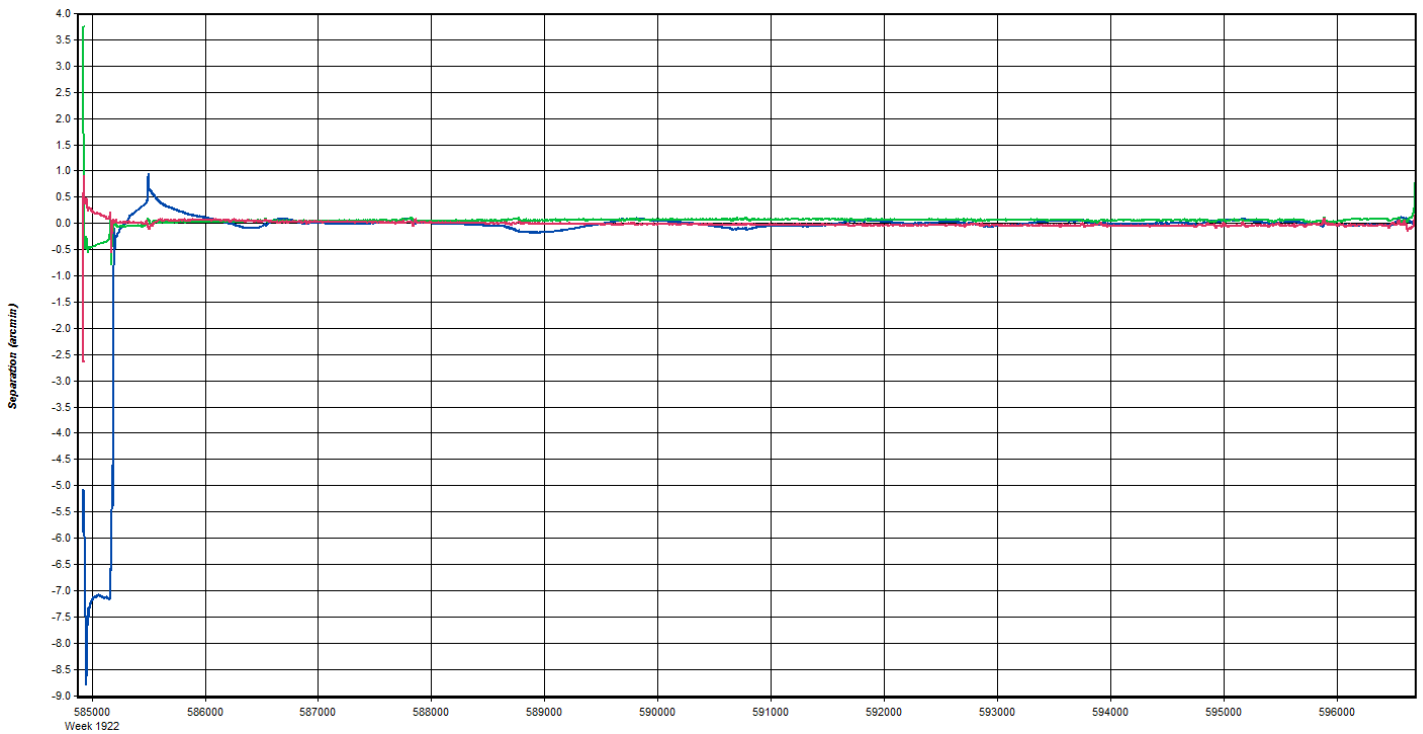

GPS Time (TOW, GMT zone)
— Roll — Pitch — Heading/Az

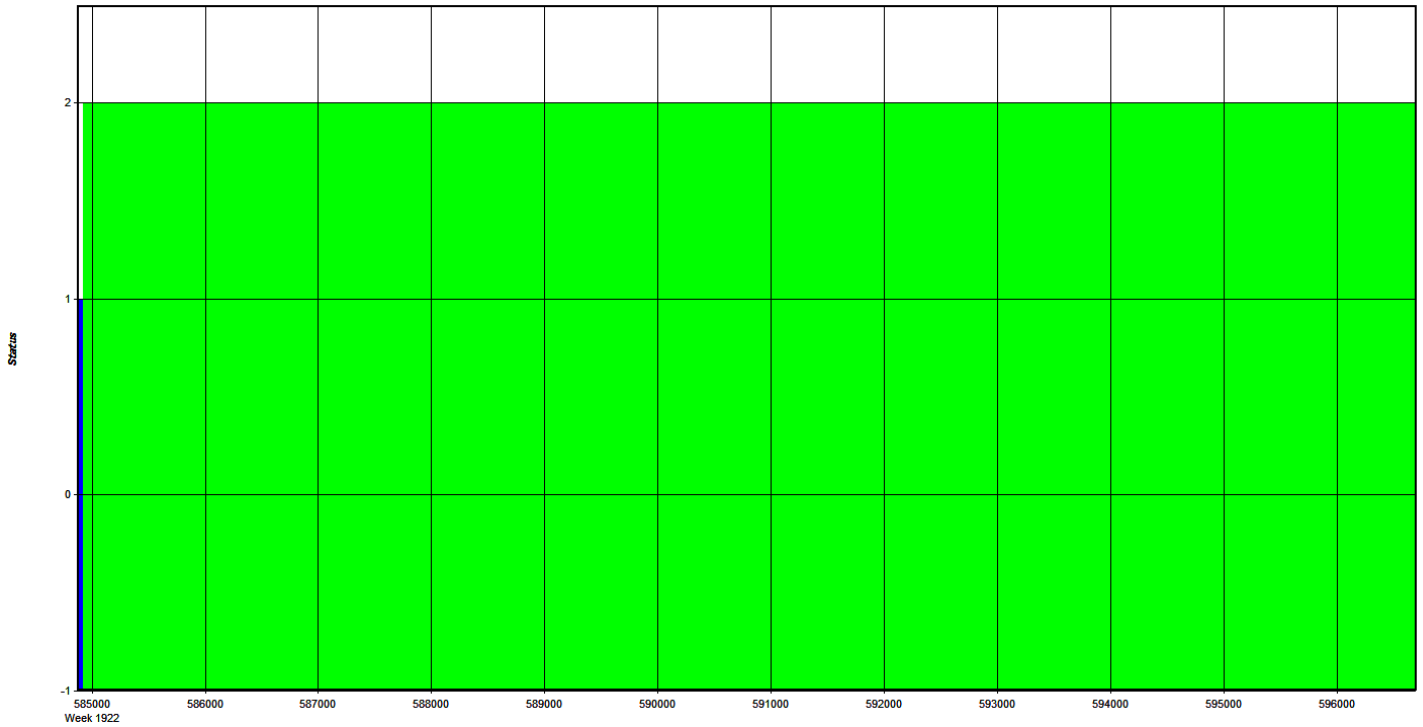

GPS Time (TOW, GMT zone)
 - Float - Forward Fixed - Reverse Fixed - Fixed (2 or more)

Coordinate/Antenna Settings

Master Remote

Base Station
 1: VTSP Name: VTSP Disabled
 File: E:\Proc\29178_VT_CT_River_Basin\From_M_Aust_11-15-16\201

Coordinates
 Latitude: North 43 16 53.24114 Compute from PPP
 Longitude: West 72 28 39.23841 Enter Grid Values
 Ellipsoidal height: 156.441 m Enter MSL Height
 Datum: WGS84 Datum Options
 Select From Favorites Add To Favorites Use Average Position

Antenna Height
 From station file: TRM55971.00, NONE View STA File
 Antenna profile: TRM55971.00 Info
 Measured height: 0.000 m
 ARP to L1 offset: 0.067 m
 Applied height: 0.067 m
 Measured to
 ARP
 L1 Phase Centre
 Compute From Slant

OK Cancel

Flight Log

Date: 11-12-16 Pg 1 of 1

(email Log daily to flight_log_distribution_list@quantumspatial.com)

Project: 1555 CT RIVER Flight Mgmt File:

Proj #: 29187 Tech: M AUST

Aircraft: 737M Begin Hobbs: 6489.3 End Hobbs: 6493.5 Total: 3.2 Pilot: J BARNUM Co-Pilot:

Dep Apt: LEB Dep Time (Lcl): 1:50 Z: 18:30 Arr Apt: LEB Arr Time (Local): 4:45 Z: 21:45 Tot Time Aloft:

CORS: N Sta 1: VTSP Sta 2: Flyovers: N If Y, times: Sta 1 1848, Sta 2 28

GPS Unit: Y / N Sta 1: Sta 2: Flyovers: Y / N If Y, times: Sta 1 Sta 2

Gd Temp beg: 6 °C End: 7 °C OAT beg: °C End: °C Altimeter begin: 30.8 end: 30.09

Type	Serial #	Alt AGL	Alt AMSL	Pulses In Air	MplA	GPS Altitude	GPS Altitude	Crab	Turb (0..4)	Avg Terr Ht	Pulse Rate	Max Gdspd	Power	Avg Pt Spacing	PPSM	Storage Name/ #		
																Log GB	End GB	Tot GB
LIDAR	FOV	7178	8.0		N						260	100						4
		40	53		N													

Line #	Hdg	Start(UTC)	End(UTC)	Gd Spd	POFF/sats	GPS Altitude	Crab	Turb (0..4)	FLIGHT LINE NOTES - visibility, clouds, smoke, partial, etc										
1014	N	1902	1914	157	10/19	7.8													
1015	S	1917	1930	152	11/18	7.8													
1016	N	1934	1947	132	11/17	7.8													
1017	S	1950	2003	157	14/15	7.8													
1018	N	2007	2020	151	13/17	7.8													
1019	S	2024	2038	156	13/17	7.8													
1020	N	2041	2055	144	12/18	7.8													
1021	S	2059	2112	161	11/17	7.8													
10001	W	2120	2102	152	14/15	7.4													

Crossflight

Total Proj Lines: Lines Flown: Lines Remain: Online Time: 2,25 Mob Time: Notes:

Nov 13, 2016-A (N22GE, SN7161)

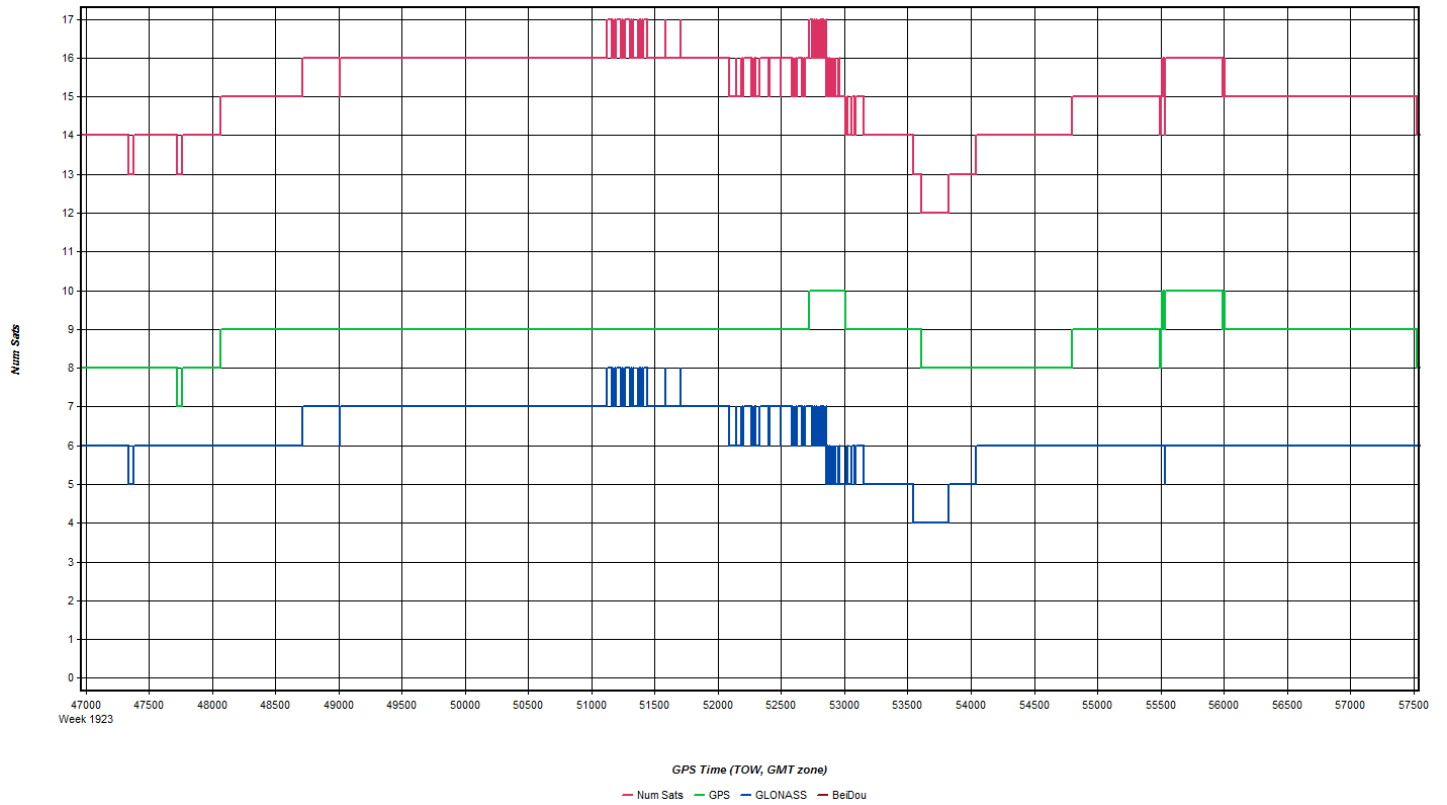
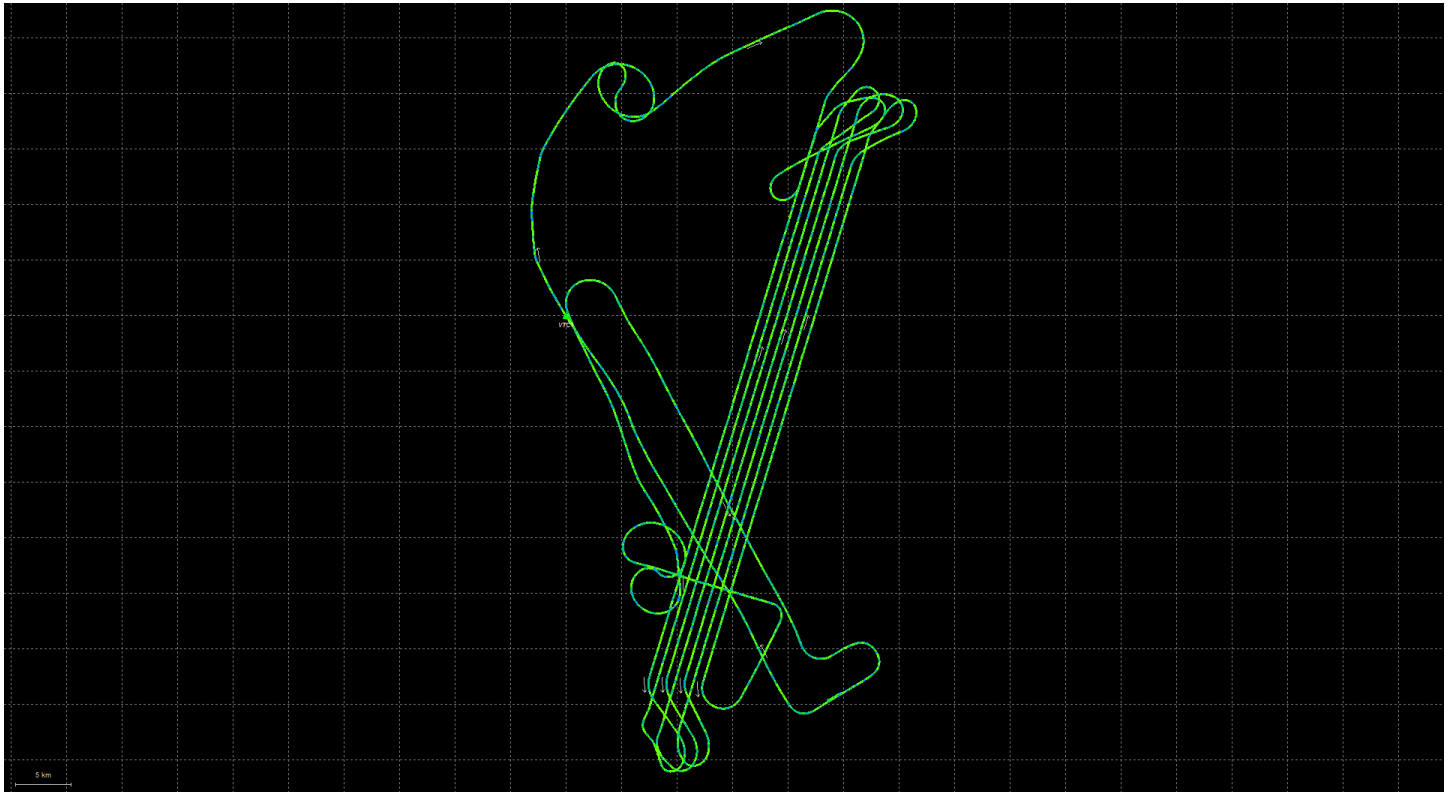

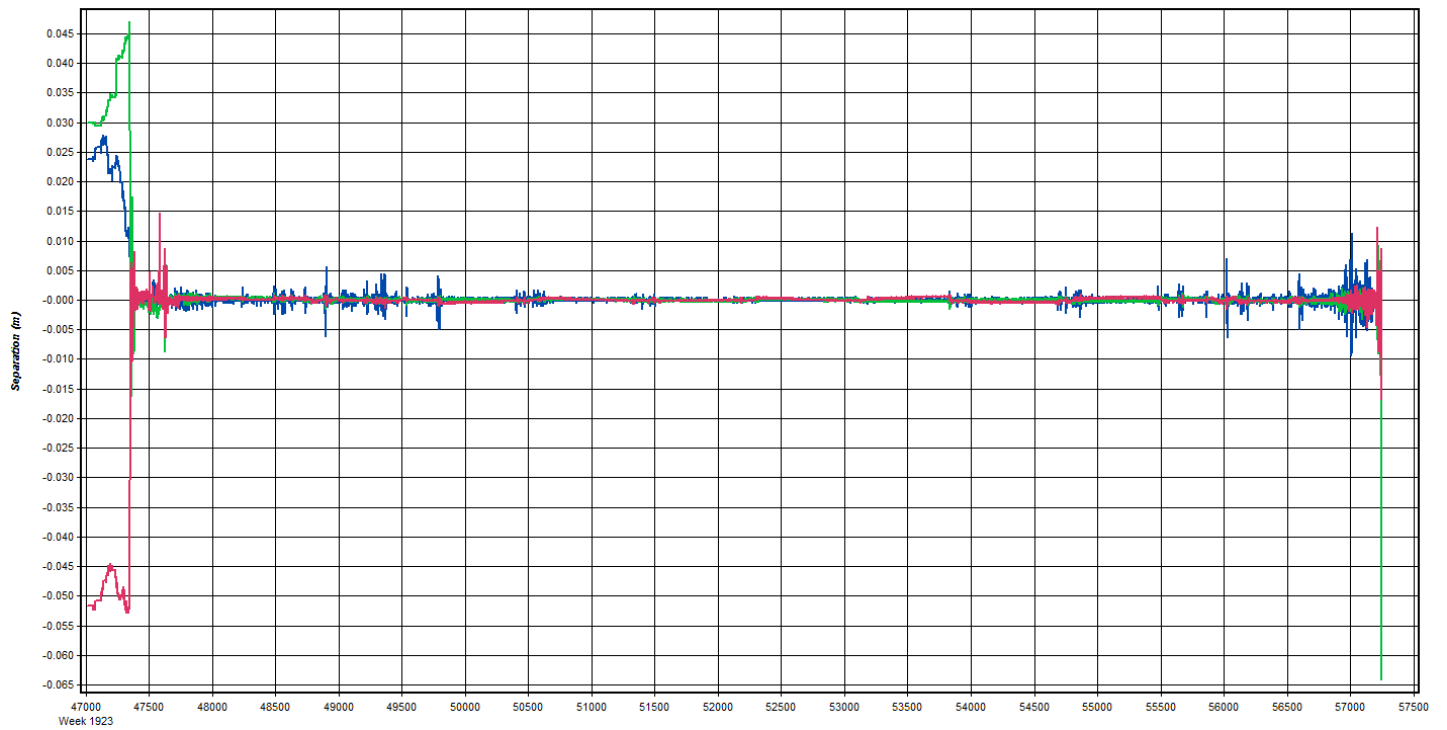

GPS Time (TOW, GMT zone)

— East — North — Up

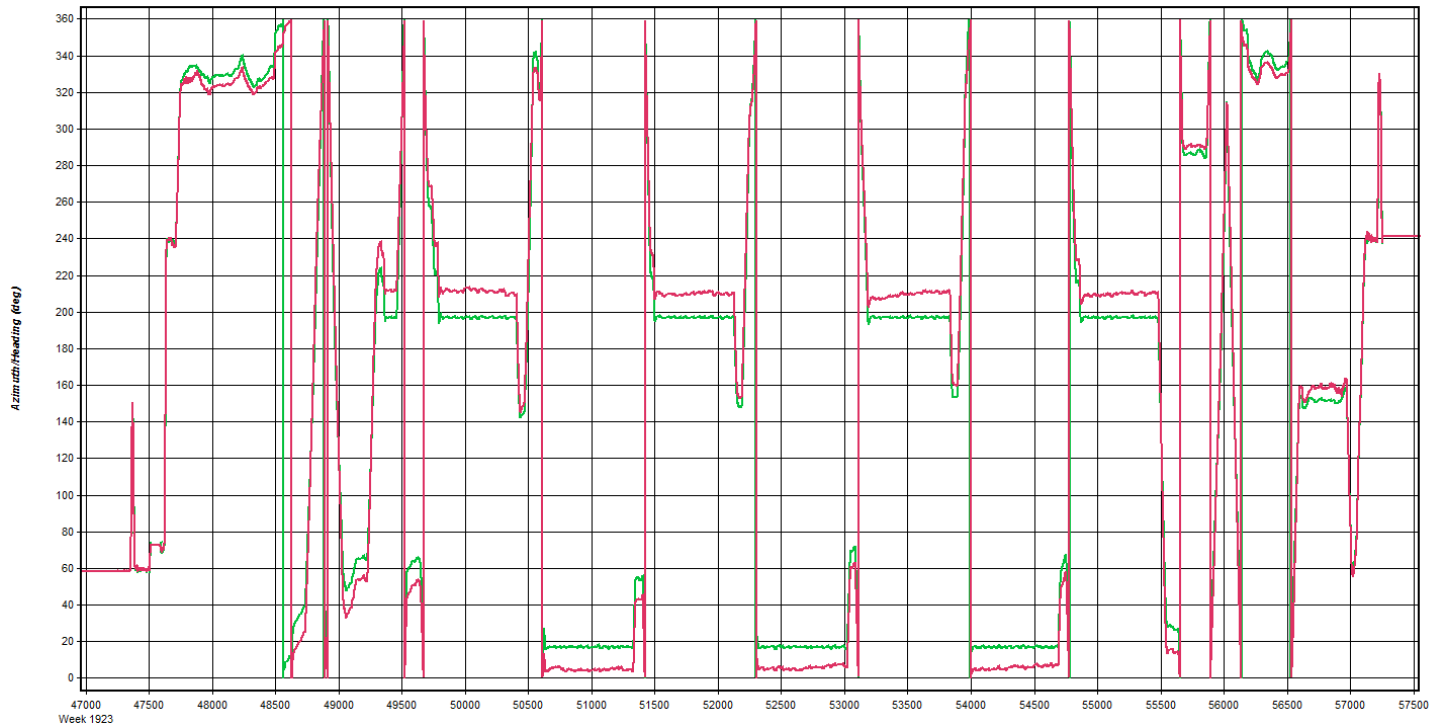

GPS Time (TOW, GMT zone)

— Heading/Azimuth — GPS-COG

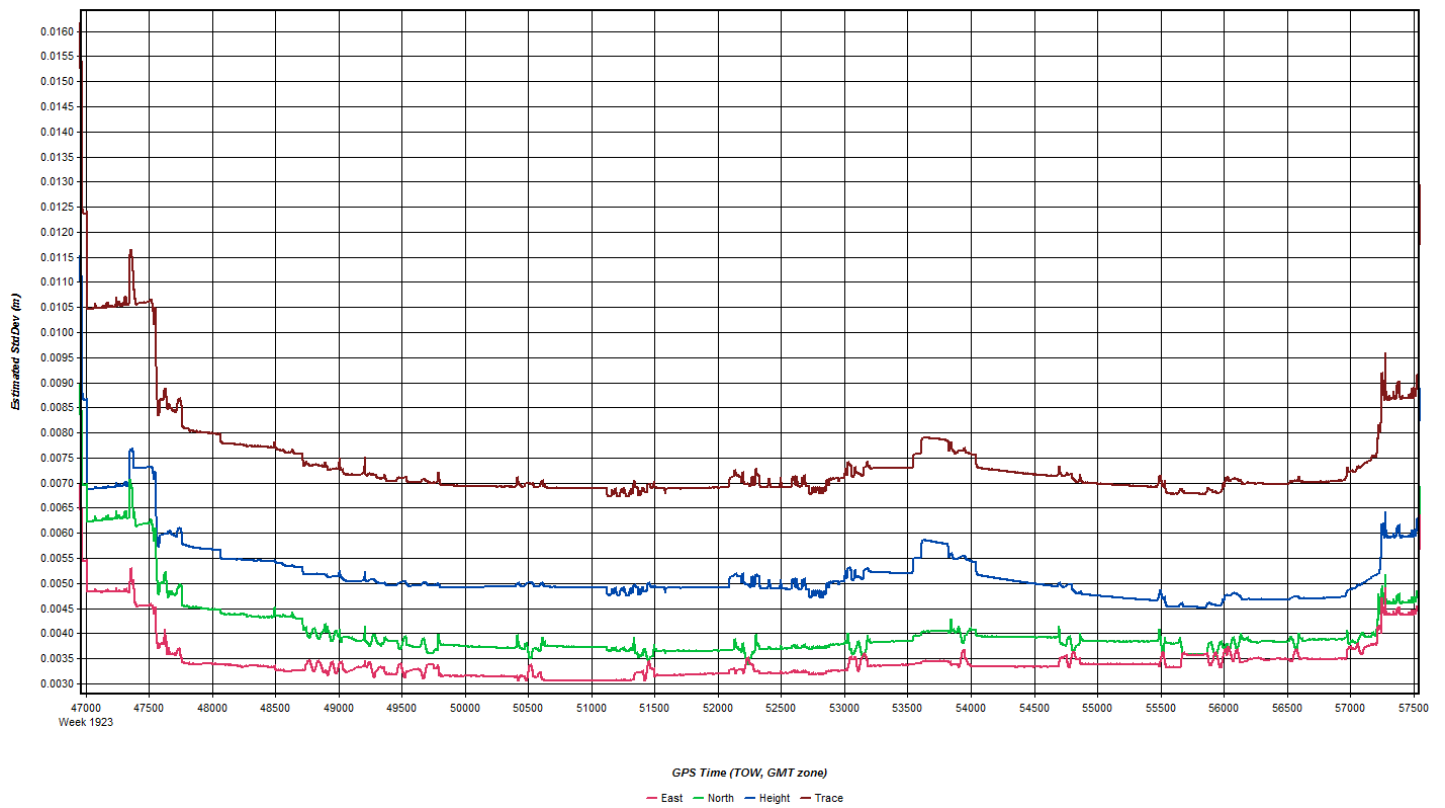

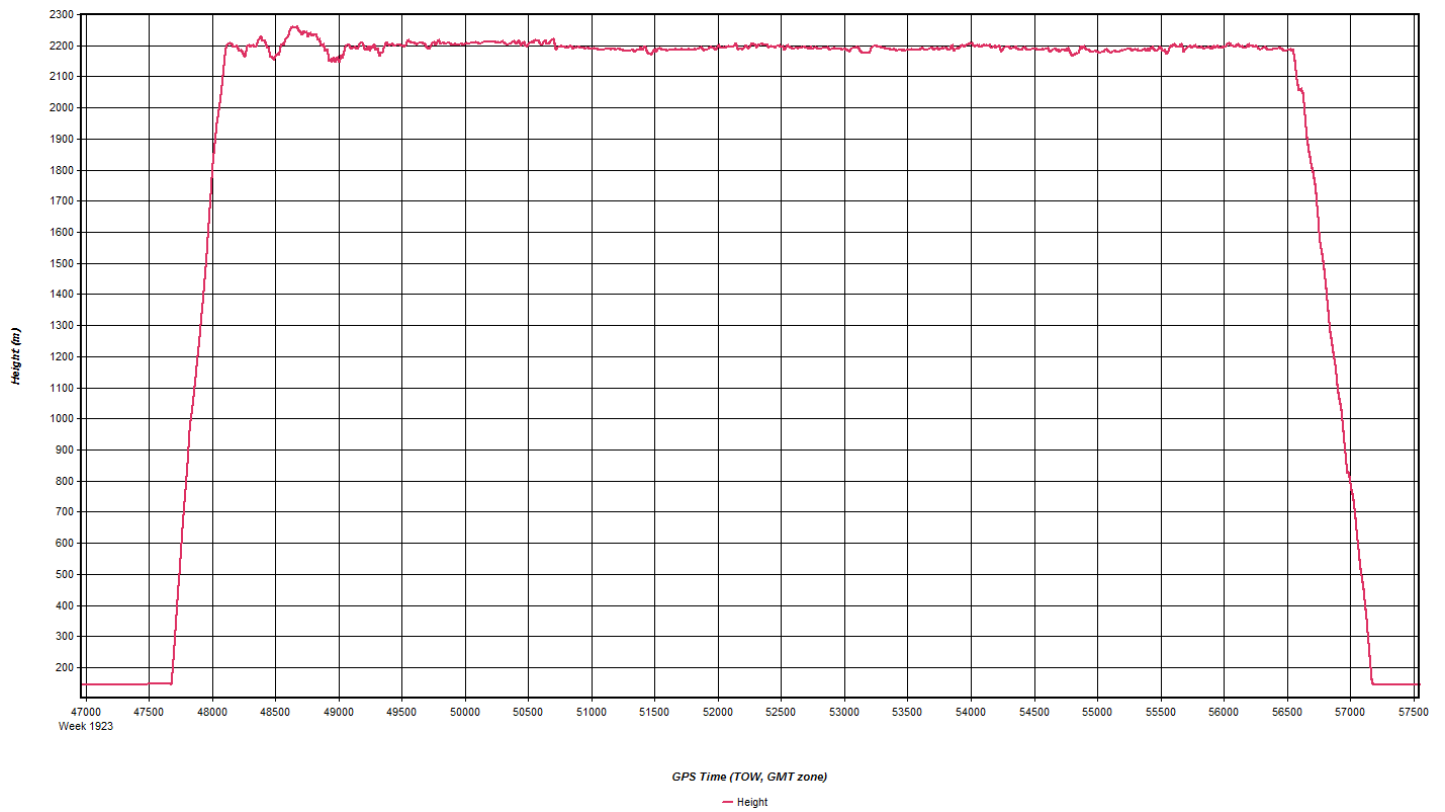
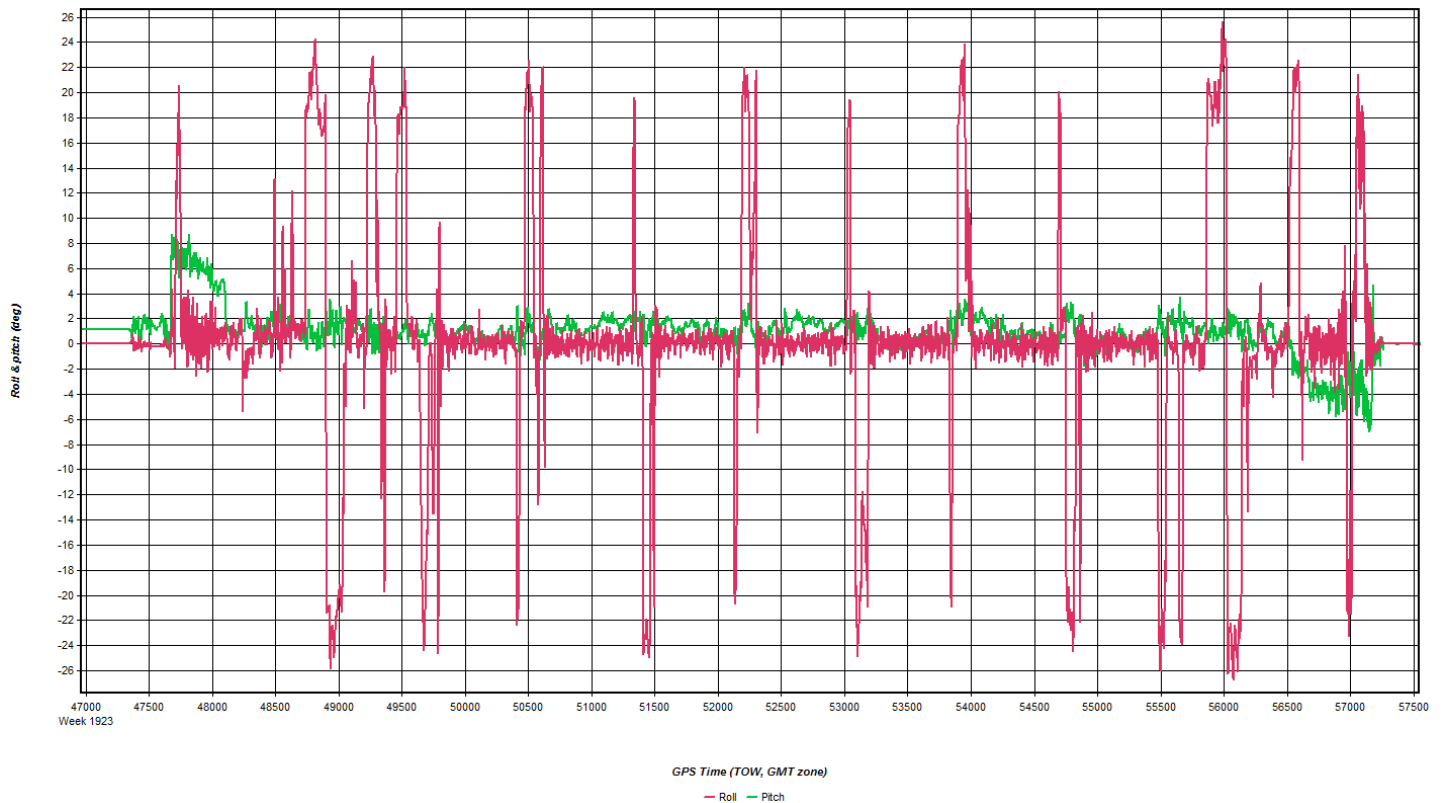

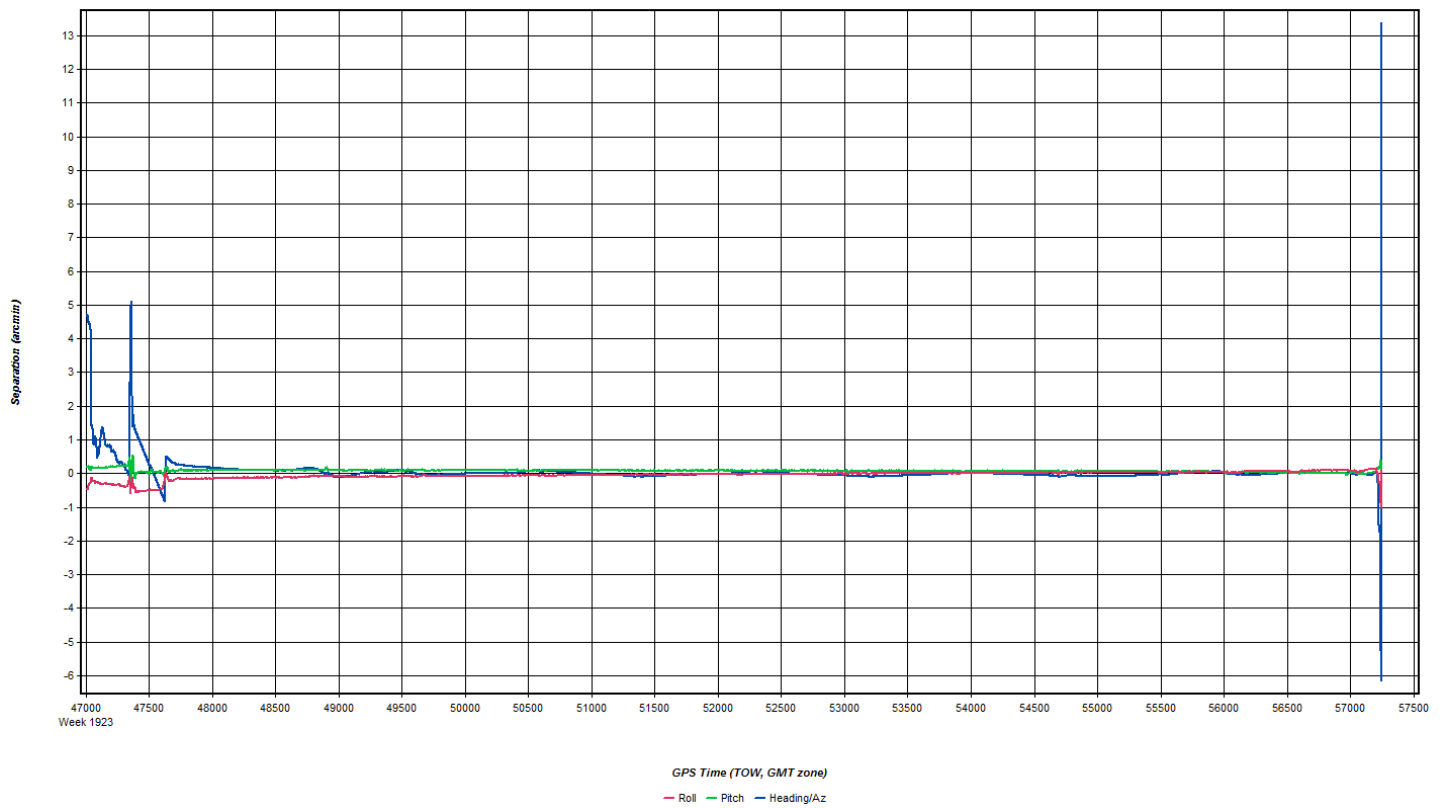
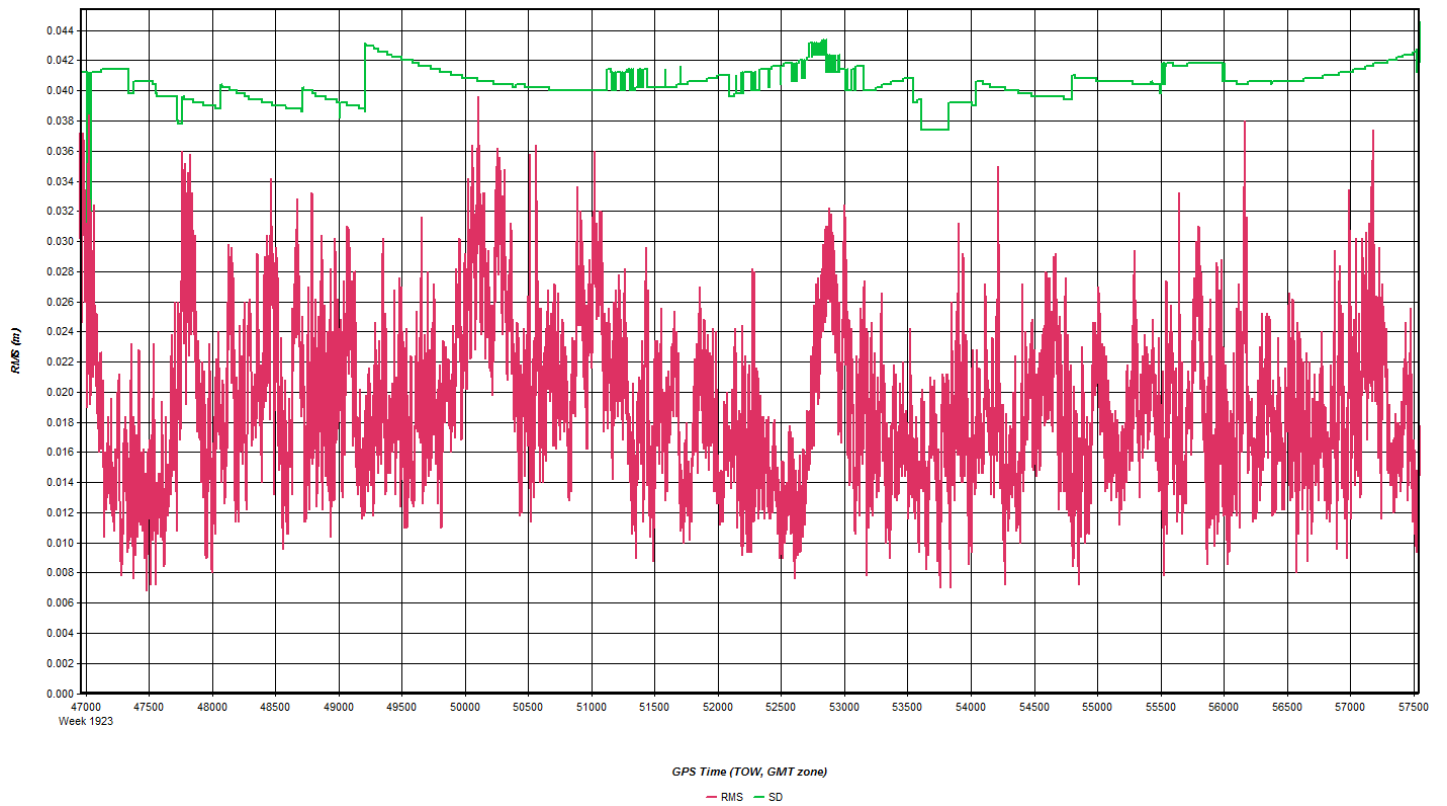

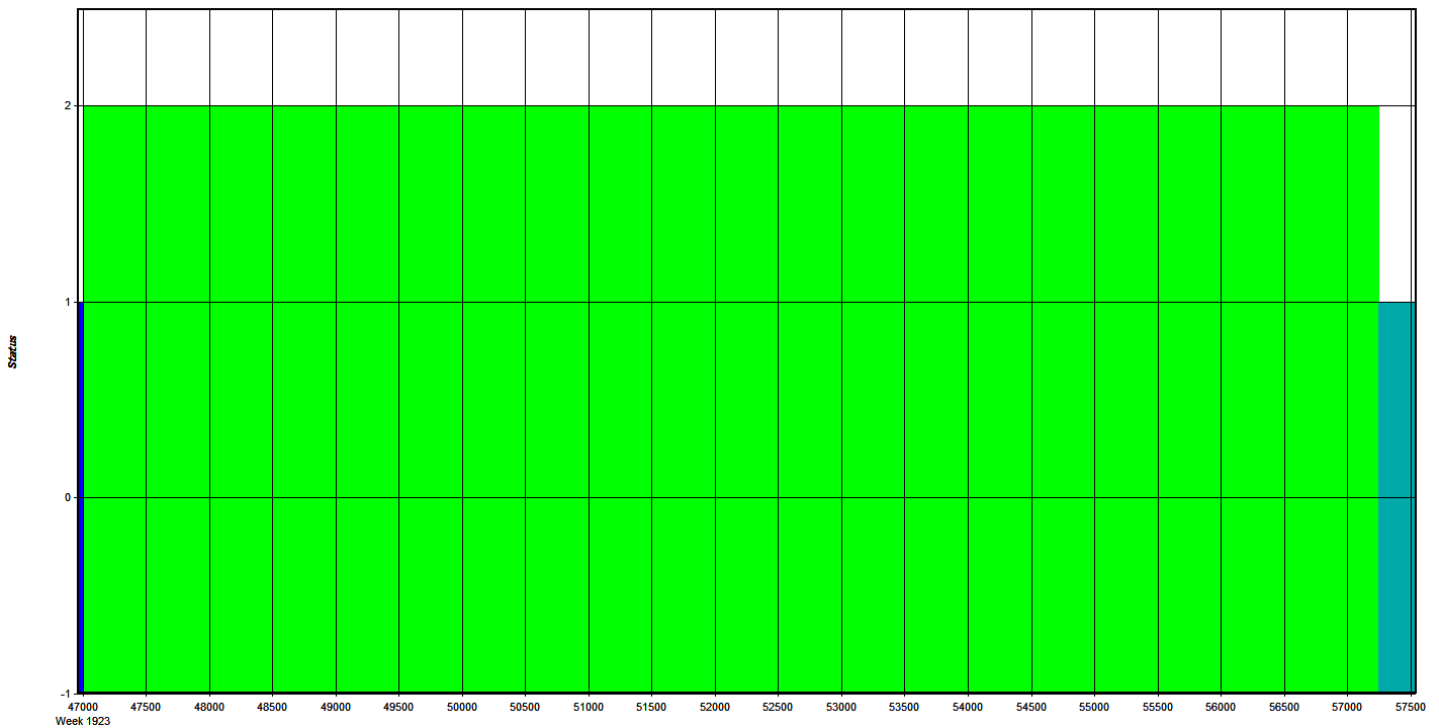

GPS Time (TOW, GMT zone)
 - Float - Forward Fixed - Reverse Fixed - Fixed (2 or more)

Coordinate/Antenna Settings

Master Remote

Base Station
 1: VTC1 Name: VTC1 Disabled
 File: E:\Proc\29178_CT_River\29178_ALS70_N22GE\20161113_125

Coordinates
 Latitude: North 43 56 21.21809 Compute from PPP
 Longitude: West 72 36 12.56537 Enter Grid Values
 Ellipsoidal height: 405.144 m Enter MSL Height
 Datum: WGS84 Datum Options
 Select From Favorites Add To Favorites Use Average Position

Antenna Height
 From station file: TRM55971.00, NONE View STA File
 Antenna profile: TRM55971.00 Info
 Measured height: 0.000 m
 ARP to L1 offset: 0.067 m
 Applied height: 0.067 m
 Measured to:
 ARP
 L1 Phase Centre
 Compute From Slant

OK Cancel

Flight Log

Scanned by CamScanner

11-13-16 29178 A
 Airborne LiDAR Data Collection Log Sheet :: Quantum Spatial, Inc
 (email log entry to flight_log_distribution_list@quantumspatial.com)

Date: 11-13-16 A Pg 1 of 2
 UIC: Q B C D E

Project: CT River - VT
 Flight Mgmt File: 2016 11 B - 125818

Aircraft: N226E Begin Hobbs: 8963.1 Total: 7.6 Pilot: TRadtke Co-Pilot: JSwan
 Tech: JSwan

Dep Apt: KLEB Dep Time (Lcl): 0815 (Z): +5 Arr Apt: KLEB Arr Time (Local): (Z): +5 Tot Time Aloft: 2.7

CORS: 01N Sta 1: VTC1 / 14827 / 1493A Sta 2: Flyovers: Y N IF Y, times: Sta1) Sta2)
 Flyovers: Y N IF Y, times: Sta1) Sta2)

GPS Unit: Y N Sta 1: 1325 / 1541 Sta 2: Flyovers: Y N IF Y, times: Sta1) Sta2)

Gd Temp beg: °C End: °C OAT beg: °C End: °C Altimeter begin: 3001 end: 3000

Line #	Hdg	Start (UTC)	End (UTC)	Gd Spd	POOP/s	GPS Altitude	Crab	Turb (0, 1)	Alt AGL	Alt AFDL	Pulses In Air	MPIA Y N	Max Galspd	Power	AVG Pt Spacing	PPSM	Mag Cb	End Cb	Tot Cb	Storage Number
		1315	1325														154	126	28	017
2037	17	1343	1344	159	13/16	7230	30°	0												
2037	17	1350	1359	137	13/16	7232	30°	0												
2038	17	1404	1415	146	13/17	7245	4°	0												
2039	17	1418	1428	159	13/16	7174	30°	0												
2040	17	1432	1443	150	11/18	7232	3°	0												
2041	17	1447	1456	180	11/18	7194	30°	0												
2042	17	1500	1510	153	11/19	7233	4°	0												
2043	17	1515	1524	168	12/18	7200	30°	0												
Xtie	257	1527	1530	130	12/17	7195	0	0												
		1530	1541																	
		1541	1553																	

LEB → VTC1
 VTC1 → 5 Figure 8's 1334-1338 → site
 40kt winds DL failed to re cord Abort
 clouds south End 6 mi - 0 mi FSE
 clouds south End ??
 clouds 0-7 mi FSE ??
 cloud 7 mi FSE ?
 cloud 22 mi FSE
 clouds 20 mi FSE
 cloud 25 mi FSE
 cloud 29-23 mi / 13-8 mi FSE
 cloud 23 mi FSE / 13 mi FSE
 cloud 29-23 mi / 13-8 mi FSE
 too many clouds KTB
 site - high - VTC1 1541 Hobbs time = 2.6
 VTC1 → KLEB ONLINE time = 1.9
 Mob time = 0.7

FLIGHT LINE NOTES - visibility, clouds, smoke, partial, etc.

Total Proj Lines: 7 Lines Flown: 7 Lines Remain: 0 Online Time: 1.9 Mob Time: 0.7 Notes: clouds / Highwind / CRAB 30

Nov 13, 2016-A (N73TM, SN7178)

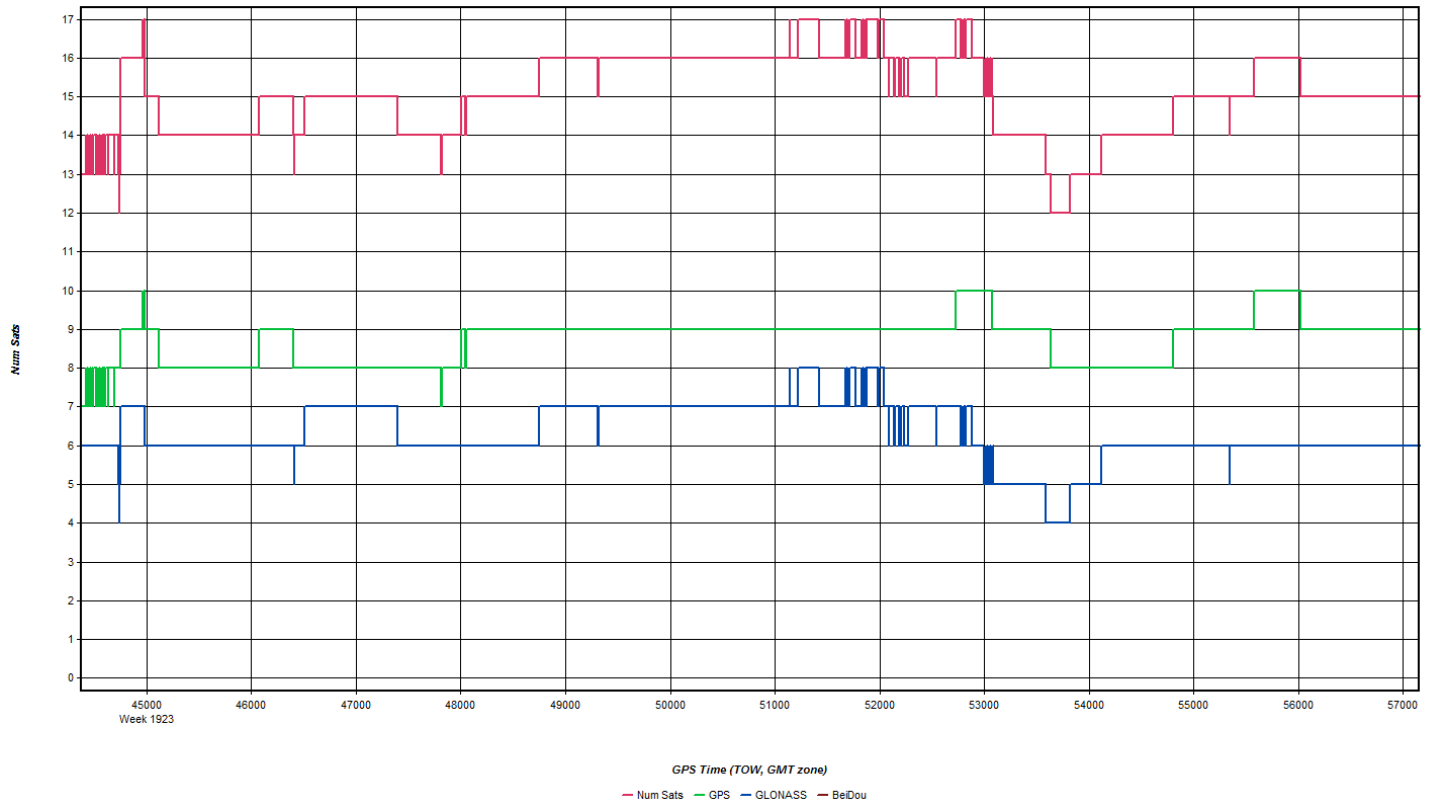
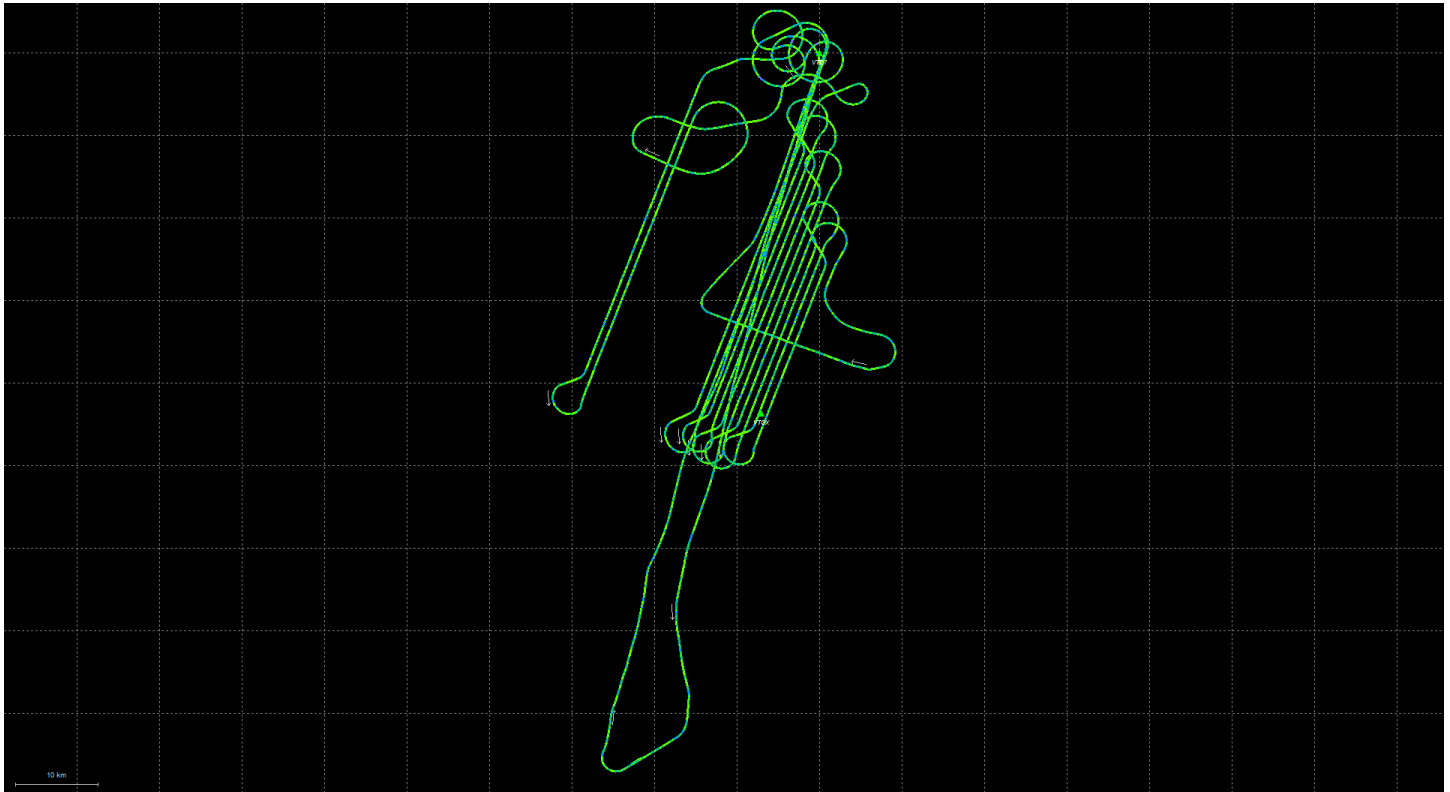

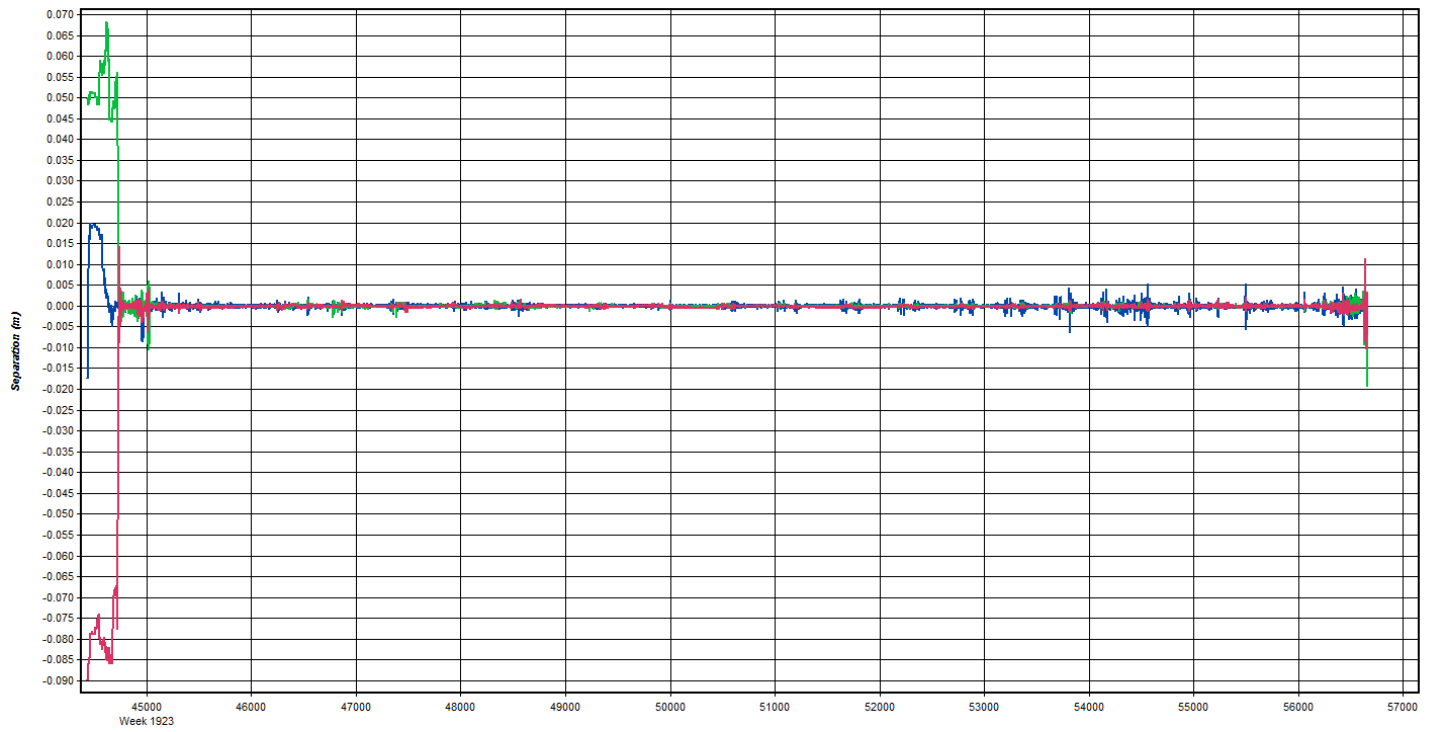

GPS Time (TOW, GMT zone)
— East — North — Up

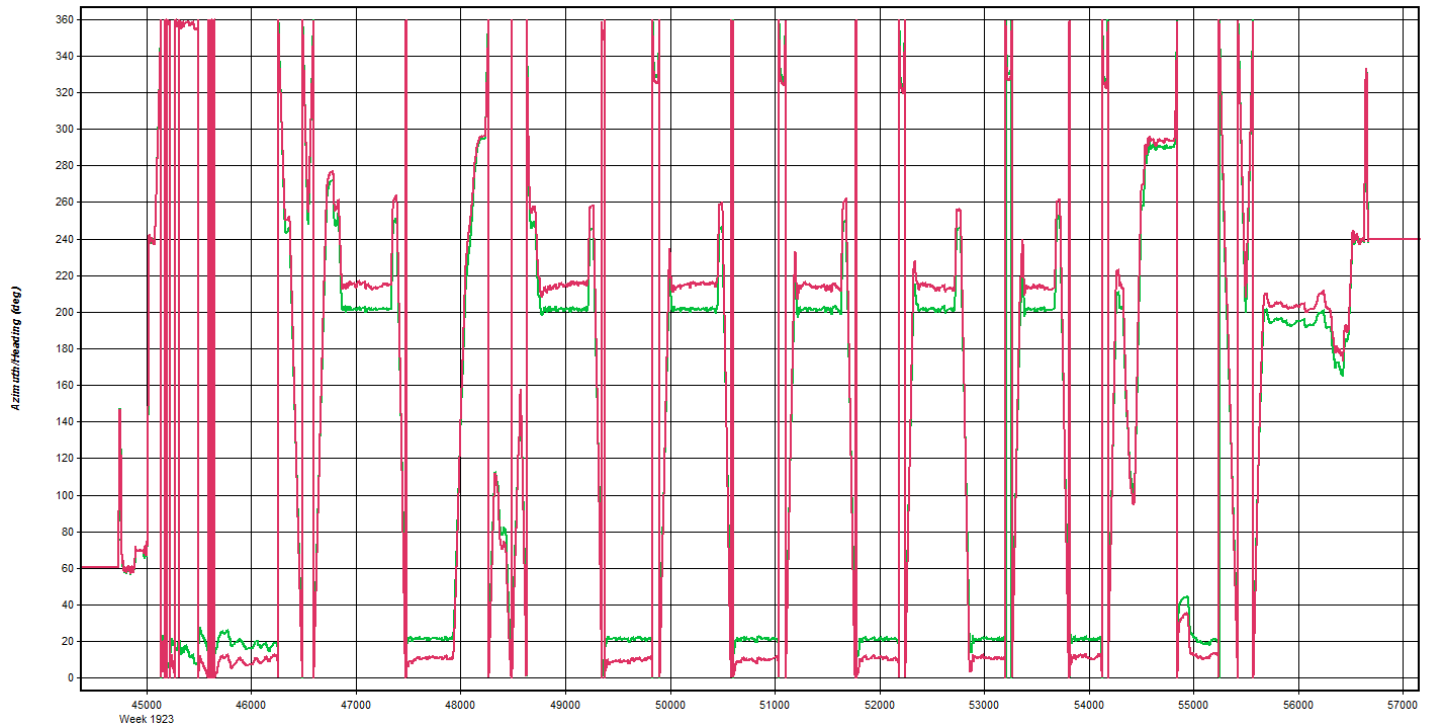

GPS Time (TOW, GMT zone)
— Heading/Azimuth — GPS-COG

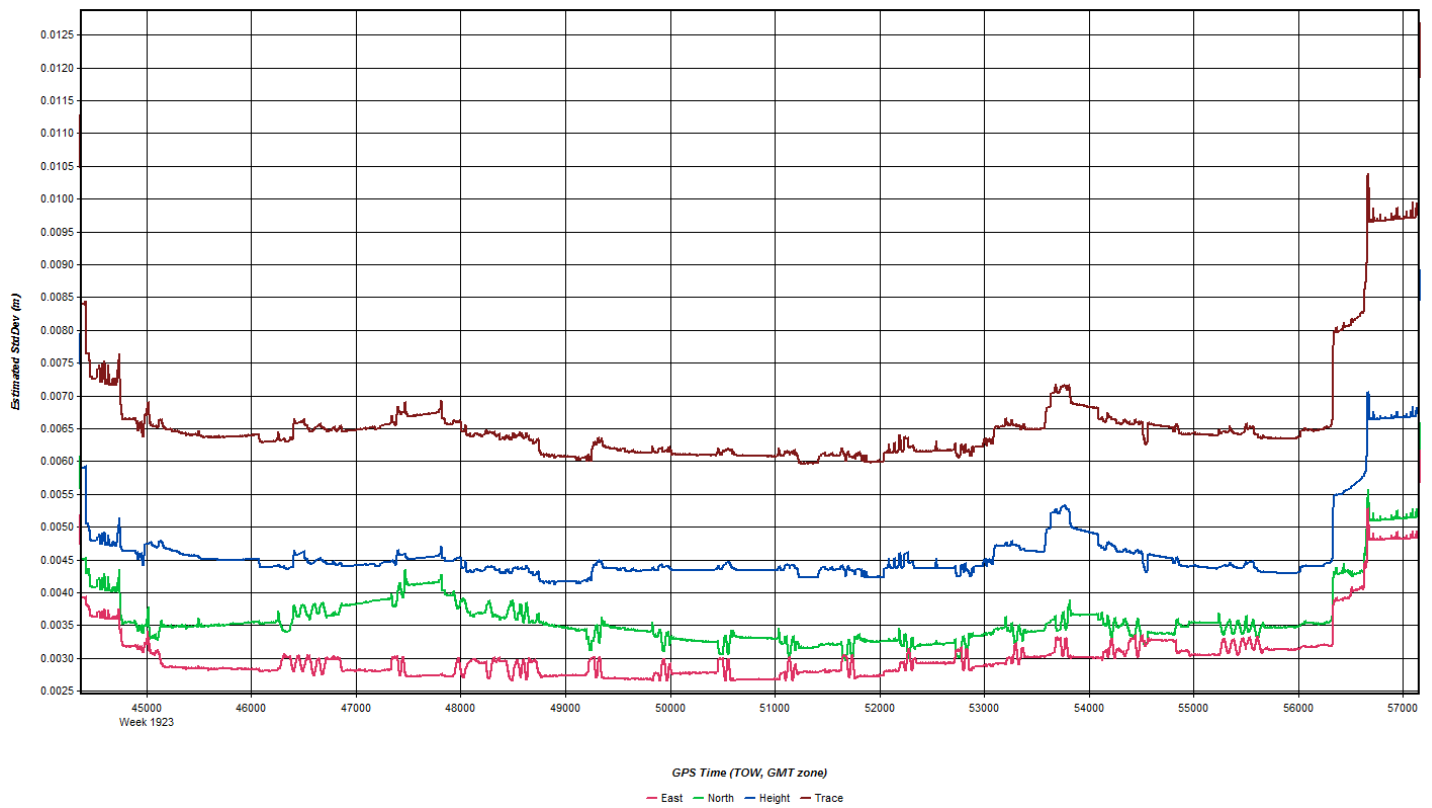
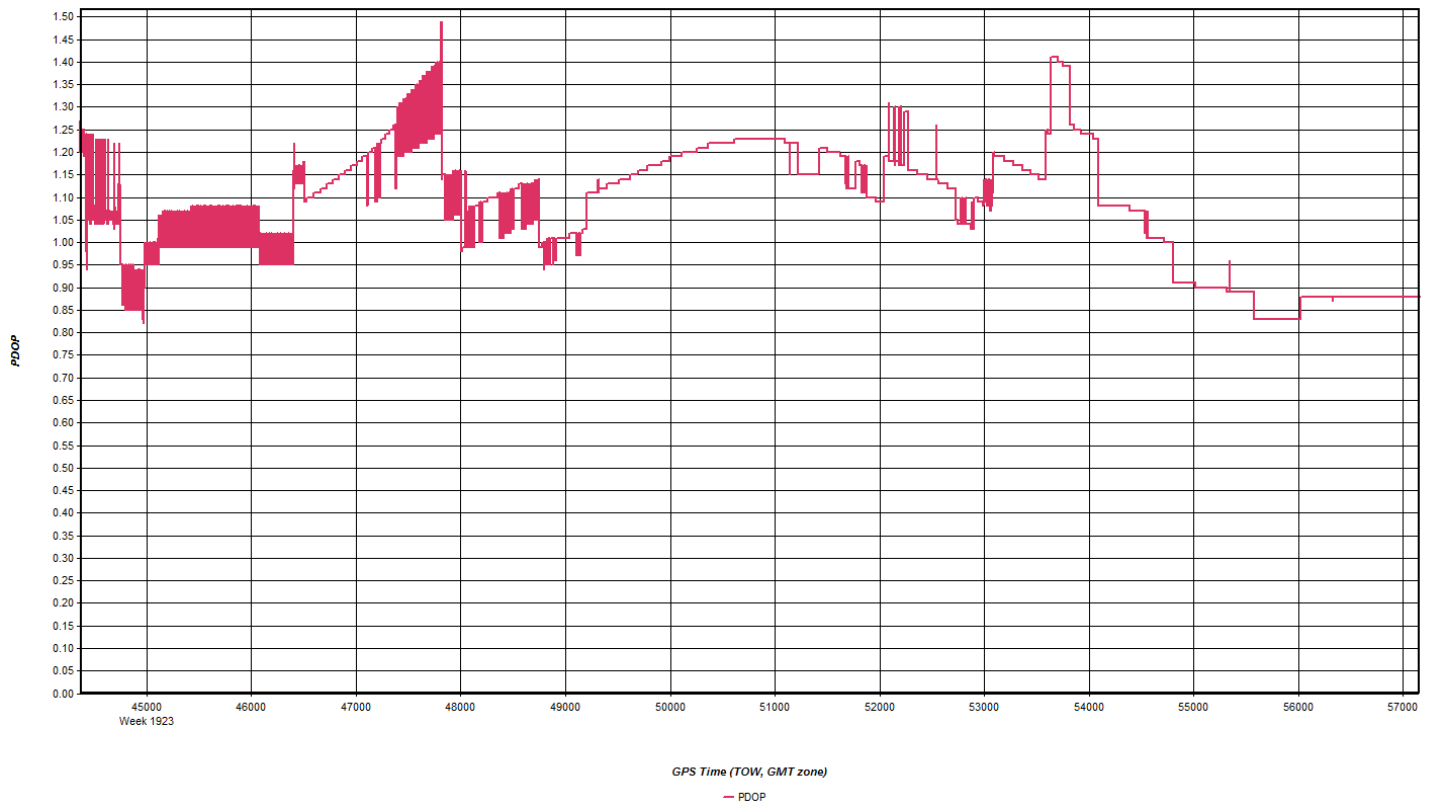

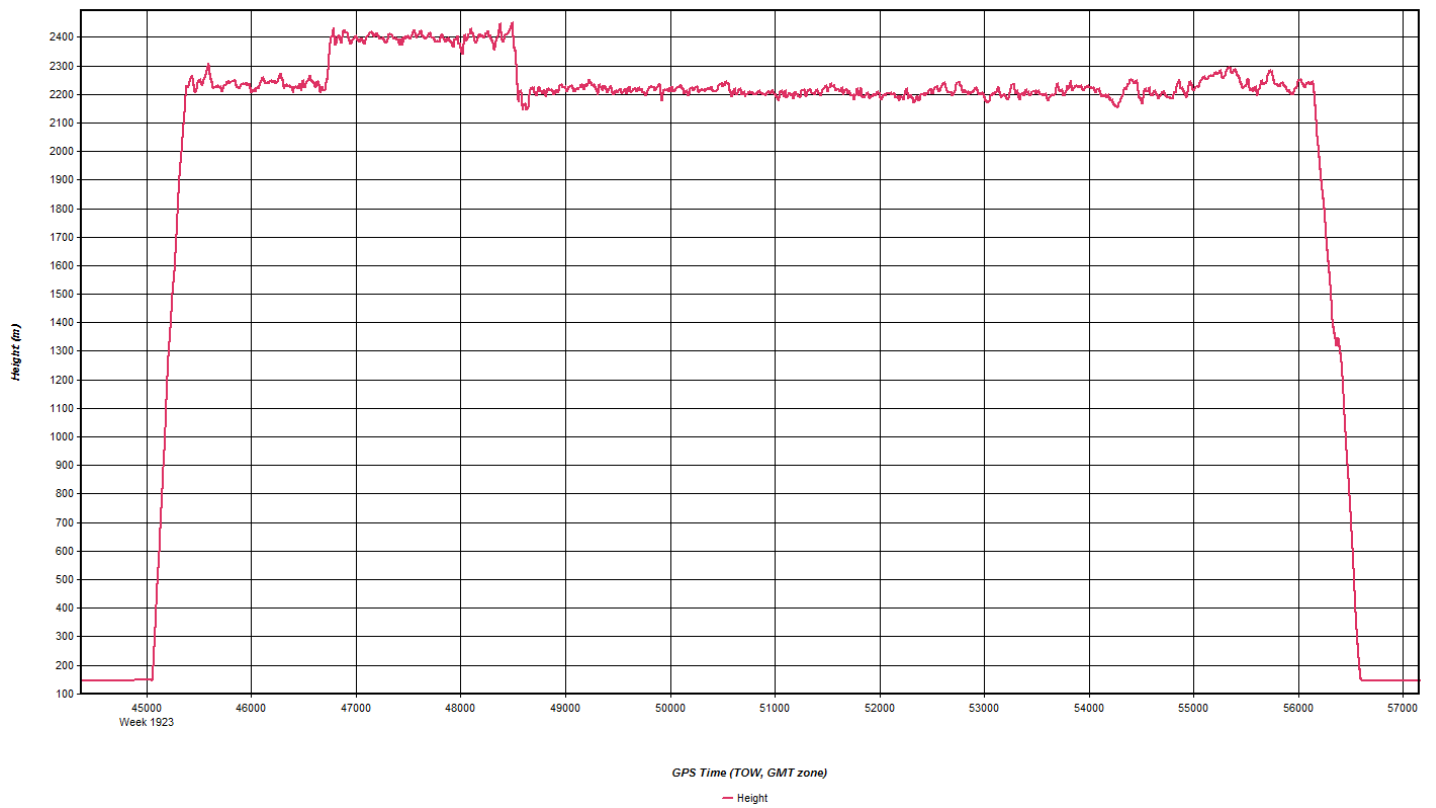
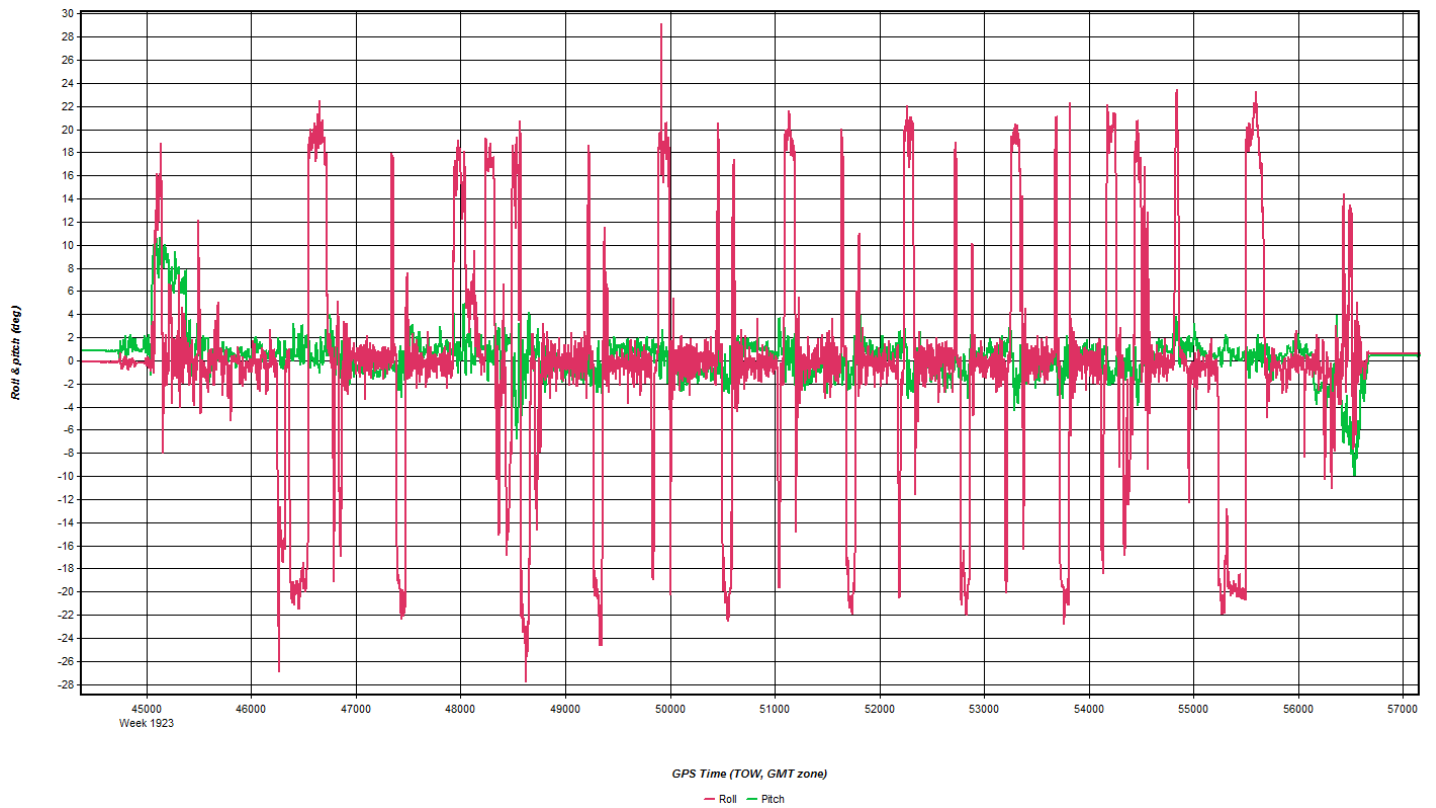

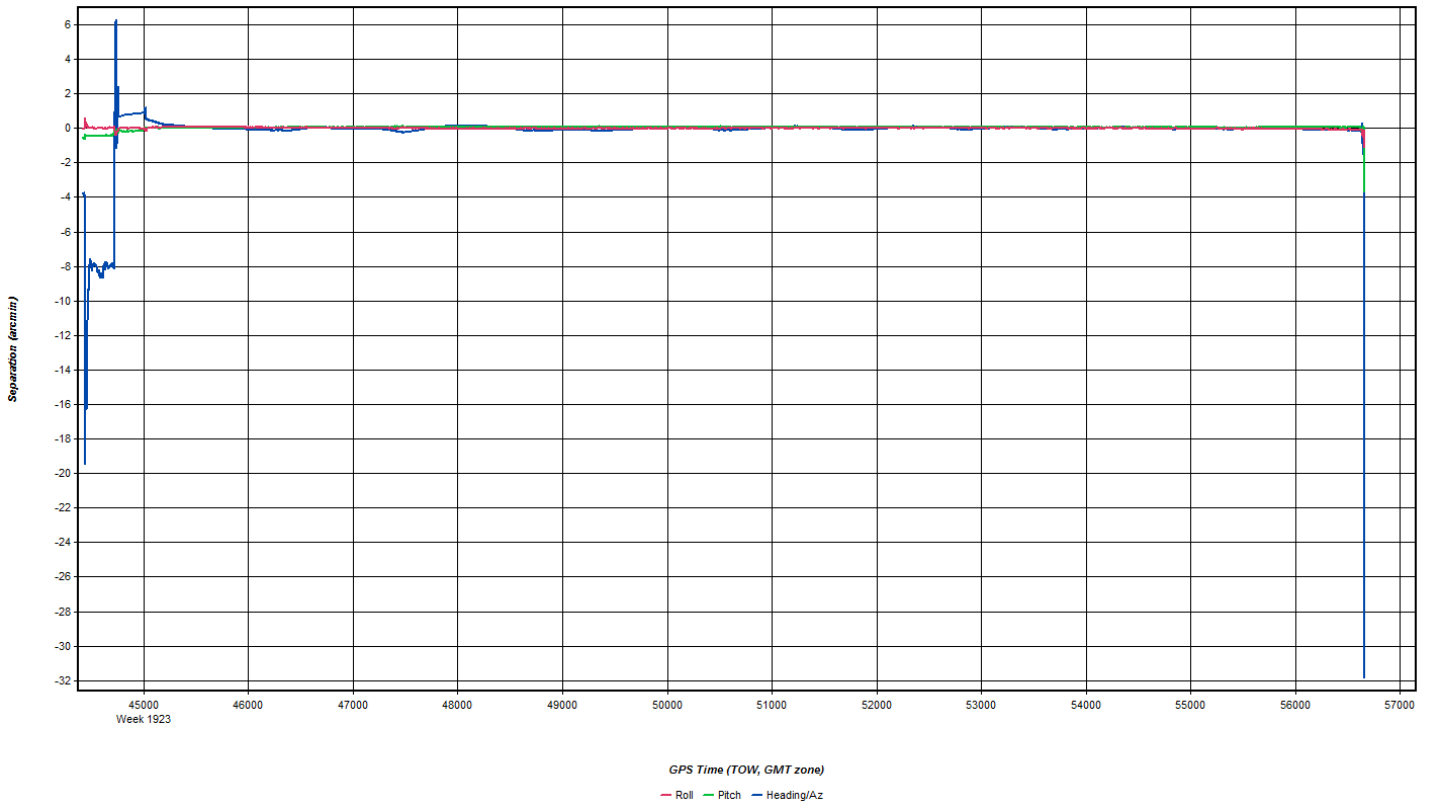
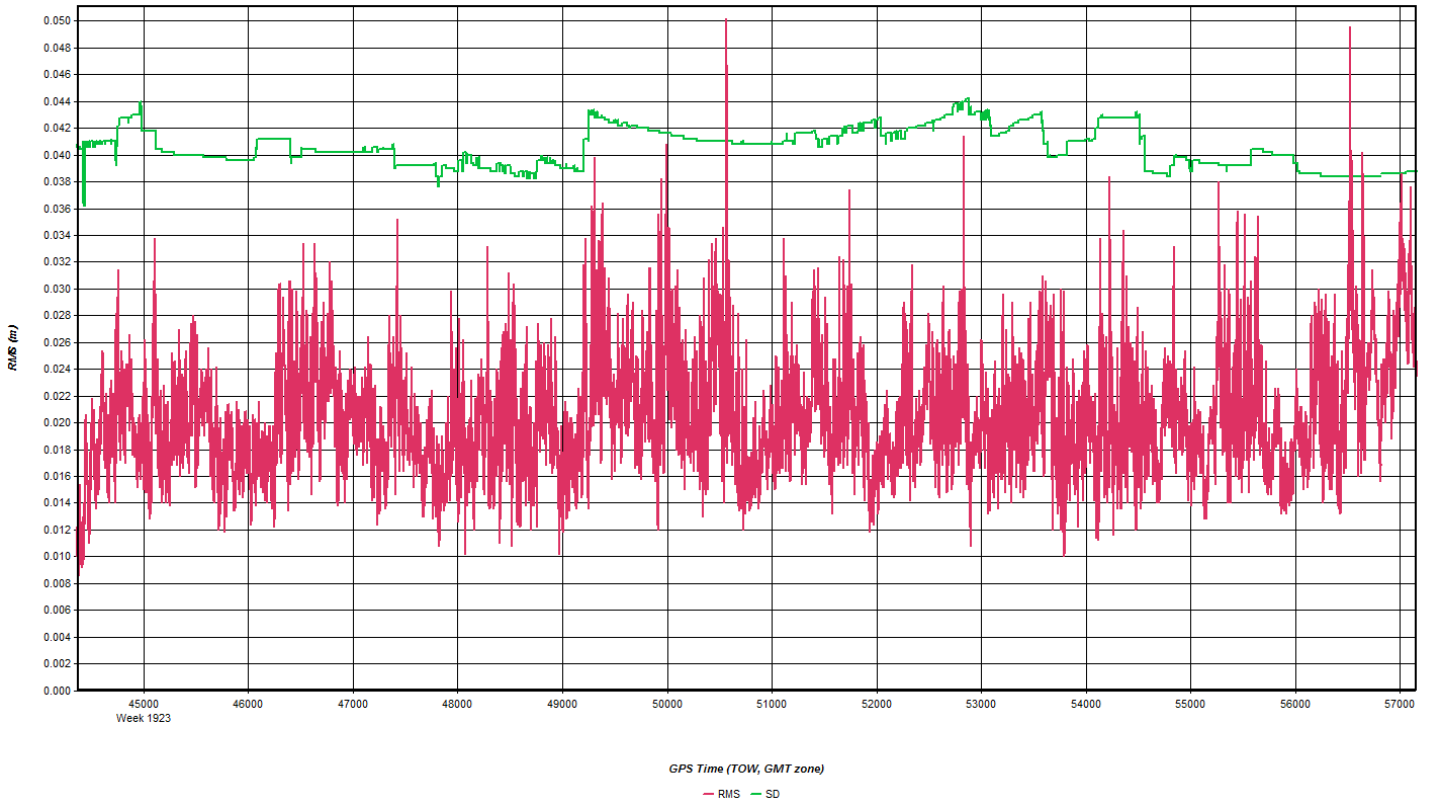

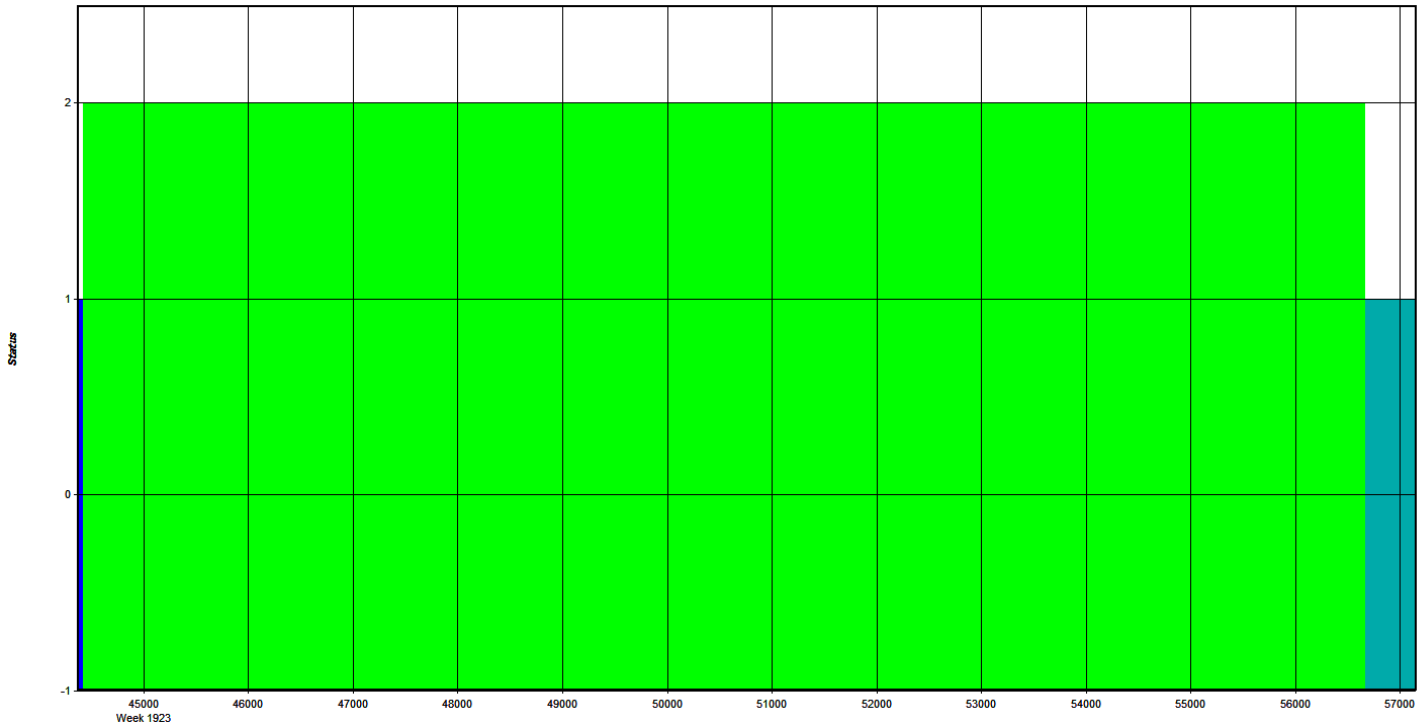

GPS Time (TOW, GMT zone)
 - Float - Forward Fixed - Reverse Fixed - Fixed (2 or more)

Coordinate/Antenna Settings

Master Remote

Base Station
 1: VTD7 Name: VTD7 Disabled
 File: E:\Proc\29178_VT_CT_River_Basin\From_M_Aust_11-15-16\201

Coordinates
 Latitude: North 44 23 52.31066 Compute from PPP
 Longitude: West 72 01 32.39267 Enter Grid Values
 Ellipsoidal height: 166.528 m Enter MSL Height
 Datum: WGS84 Datum Options
 Select From Favorites Add To Favorites Use Average Position

Antenna Height
 From station file: TRM55971.00, NONE View STA File
 Antenna profile: TRM55971.00 Info
 Measured height: 0.000 m
 ARP to L1 offset: 0.067 m
 Applied height: 0.067 m
 Measured to
 ARP
 L1 Phase Centre
 Compute From Slant

OK Cancel

Coordinate/Antenna Settings ? X

Master Remote

Base Station
2: VTOX Name: VTOX Disabled
File: E:\Proc\29178_VT_CT_River_Basin\From_M_Aust_11-15-16\201

Coordinates
Latitude: North 44 00 28.16564 Compute from PPP
Longitude: West 72 06 51.60957 Enter Grid Values
Ellipsoidal height: 126.405 m Enter MSL Height
Datum: WGS84 Datum Options
Select From Favorites Add To Favorites Use Average Position

Antenna Height
From station file: TRM55971.00, NONE View STA File
Antenna profile: TRM55971.00 Info
Measured height: 0.000 m
ARP to L1 offset: 0.067 m
Applied height: 0.067 m
Measured to:
 ARP
 L1 Phase Centre
Compute From Slant

OK Cancel

Flight Log

Date: 11-13-16 Pg. 1 of 1

(email log daily to flight_log_distribution_list@quantumspatial.com)

Project: 1555 CT RIVER LIDAR **Proj #:** 29178 **Flight Mgmt File:**

Aircraft: 737M **Begin Hobbs:** 6492.5 **End Hobbs:** 6495.7 **Total:** 3.2 **Pilot:** J. B. BULLMAN **Co-Pilot:** M. ALUST

Dep Apt: LEB **Dep Time (Lcl):** 7:30 **(Z):** 12:30 **Arr Apt:** LEB **Arr Time (Local):** 10:45 **(Z):** 15:45 **Tot Time Aloft:** 3:25

CORS: (Y) N **Sta 1:** VT07 **Sta 2:** **Flyovers:** (Y) N **If Y, times: Sta 1:** 12:50, 15:50 **Sta 2:**

GPS Unit: Y / N **Sta 1:** **Sta 2:** **Flyovers:** Y / N **If Y, times: Sta 1:** **Sta 2:**

Gd Temp beg:		°C		End:		°C		OAT beg:		°C		End:		°C		Altimeter begin:		end:		Storage Name/ #	
Type	Serial #	Alt AGL	Alt AMSL	Avg Terr Ht	Max Gdspd	Power	Pulse Rate	Avg Pt Spacing	PPSM	Beg GB	End GB	Tot GB	Storage Name/ #								
LIDAR	71570	7178	8.0	8.0	100	100	260						4								
FOV	40	53	MPIA (Y) N																		

Line #	Hdg	Start (UTC)	End (UTC)	Gd Spd	PDOP/Stars	GPS Altitude	Crab	Turb (0..4)	FLIGHT LINE NOTES - visibility, clouds, smoke, partial, etc.
3073	201°	1301	1308	155	1.1/16	7.2			
3074	211°	1311	1318	165	1.1/17	7.2			
3075	201°	1322	1323	137	1.2/17	7.2			
3076	201°	1333	1339	160	1.2/16	7.2			
3077	201°	1343	1350	147	1.3/16	7.3			
3078	201°	1353	1400	155	1.3/17	7.3			
3079	201°	1403	1410	146	1.3/16	7.2			
3080	201°	1414	1420	156	1.2/17	7.2			
3081	201°	1423	1429	154	1.2/17	7.2			
3082	201°	1433	1438	153	1.1/19	7.2			
3083	201°	1441	1446	159	1.1/17	7.2			
3084	201°	1449	1454	155	1.0/18	7.2			
3199	201°	1457	1501	137	1.0/19	7.2			
3199	290°	1457	1513	135	1.2/16	7.2			CROSSFLIGHT

Total Proj Lines:	Lines Flown:	Lines Remain:	Online Time: 2:25	Job Time: 1	Notes:
--------------------------	---------------------	----------------------	--------------------------	--------------------	---------------

Nov 13, 2016-B (N22GE, SN7161)

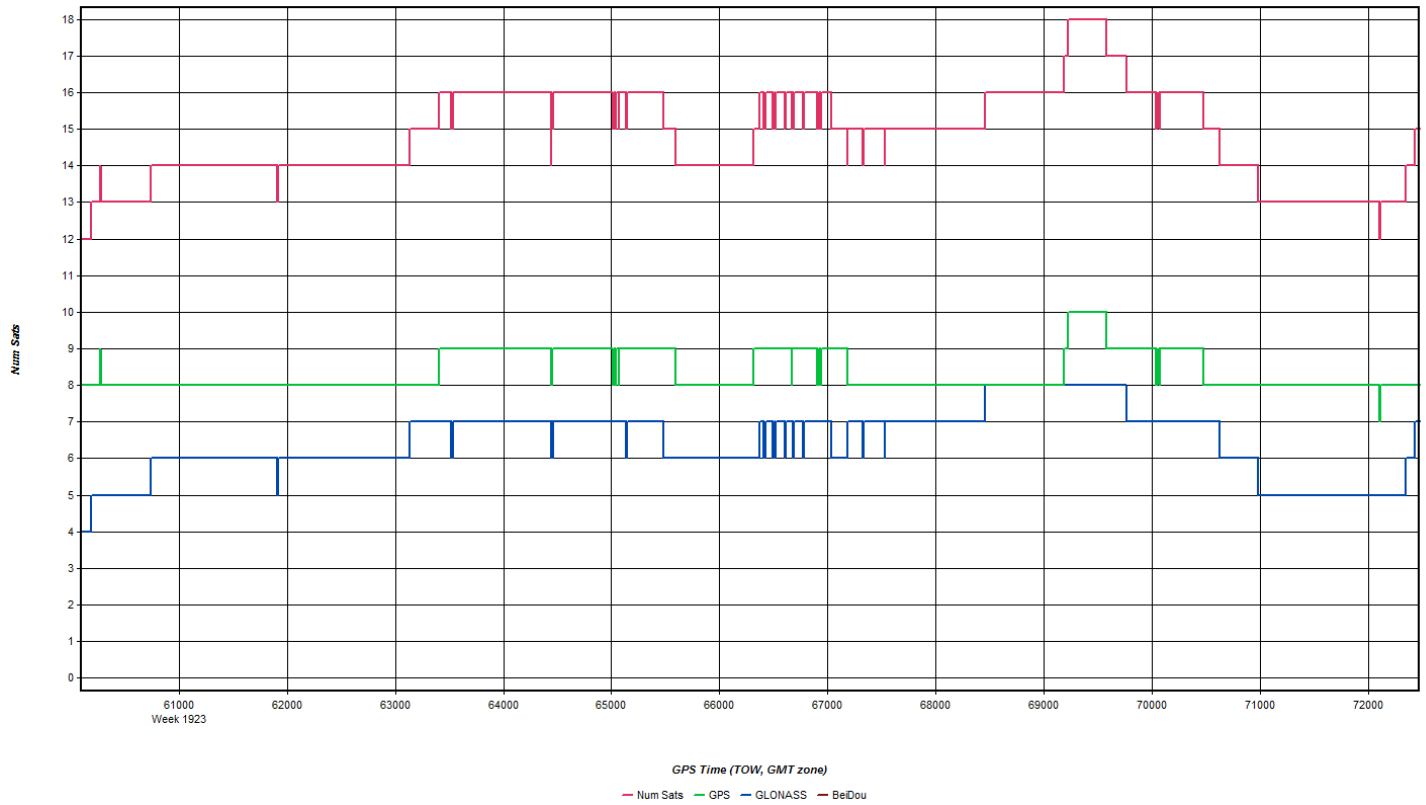
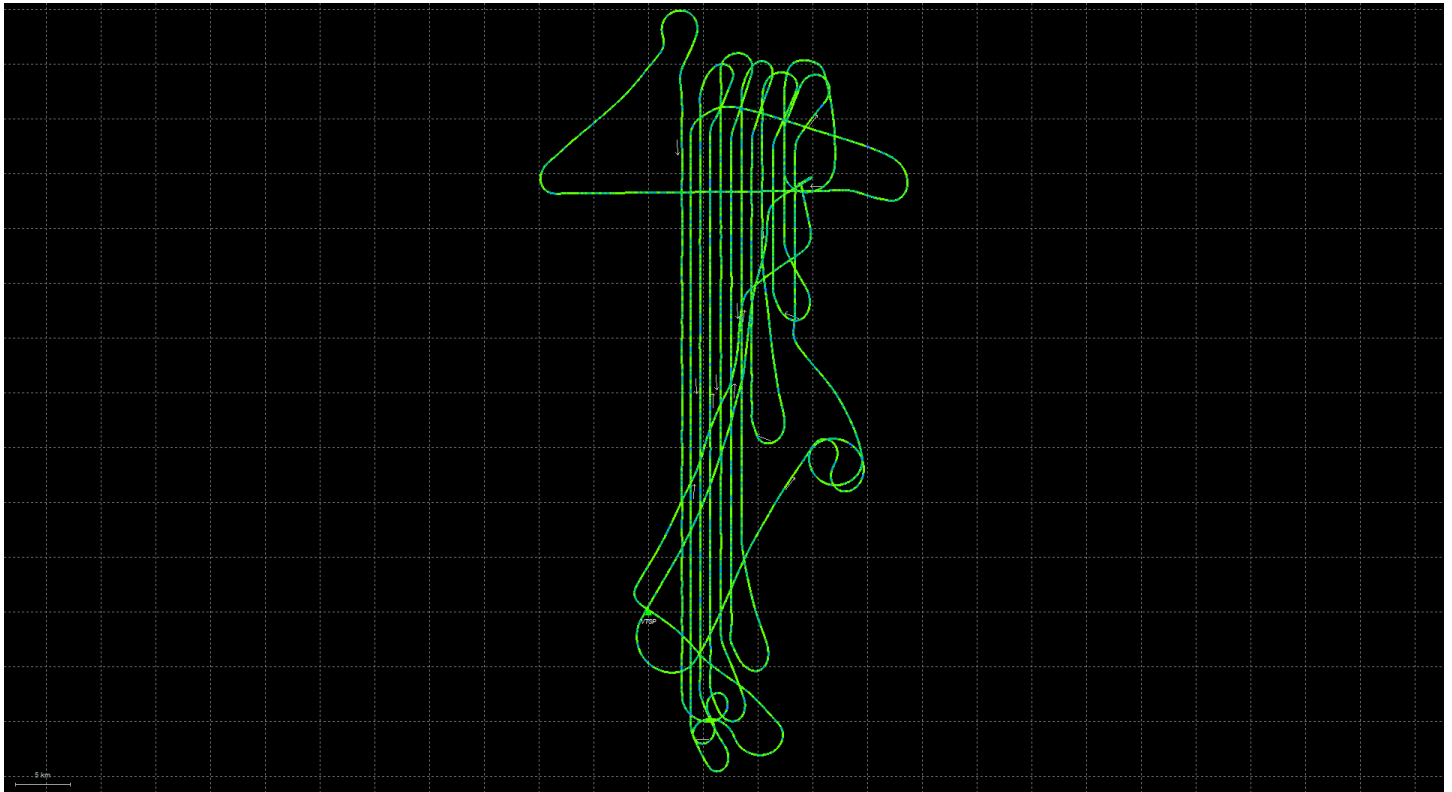

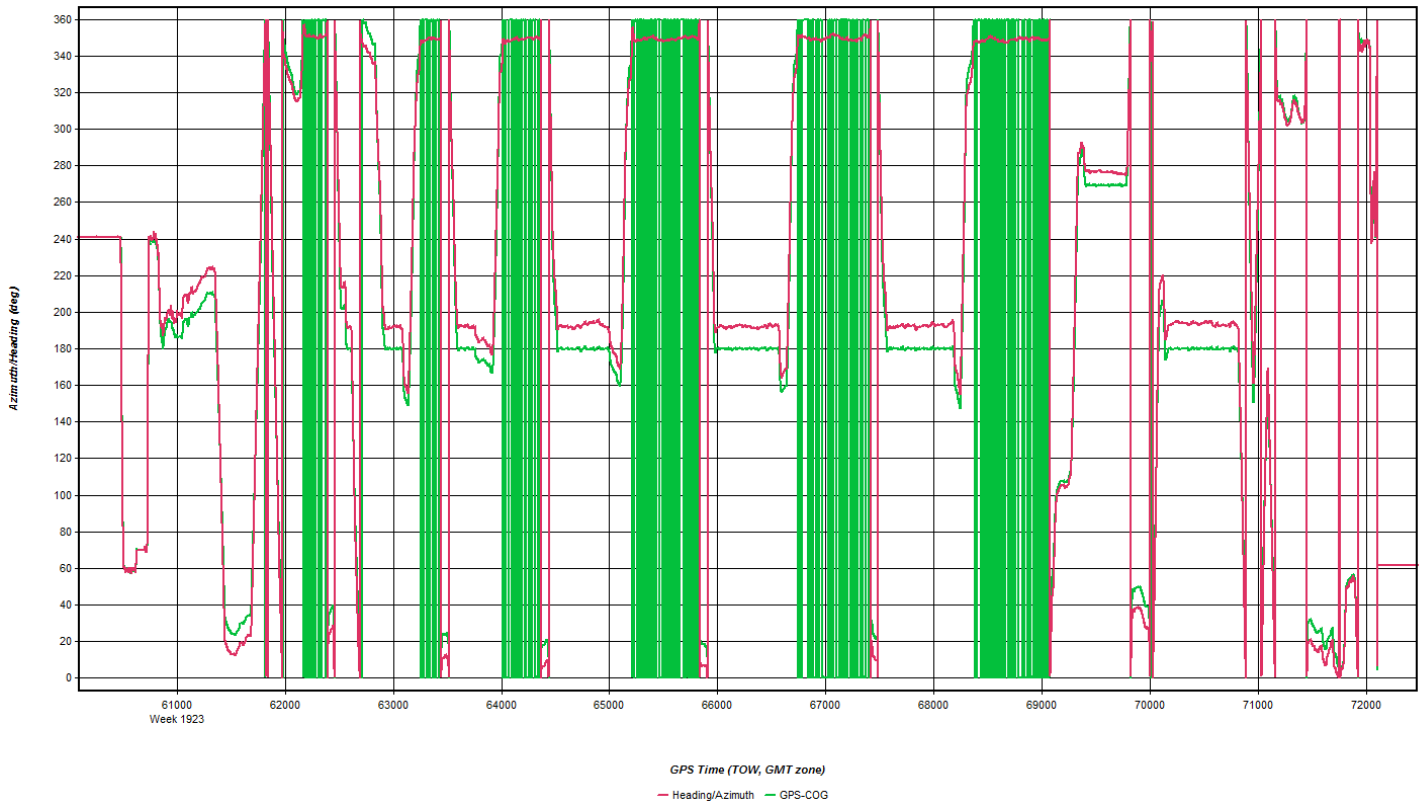
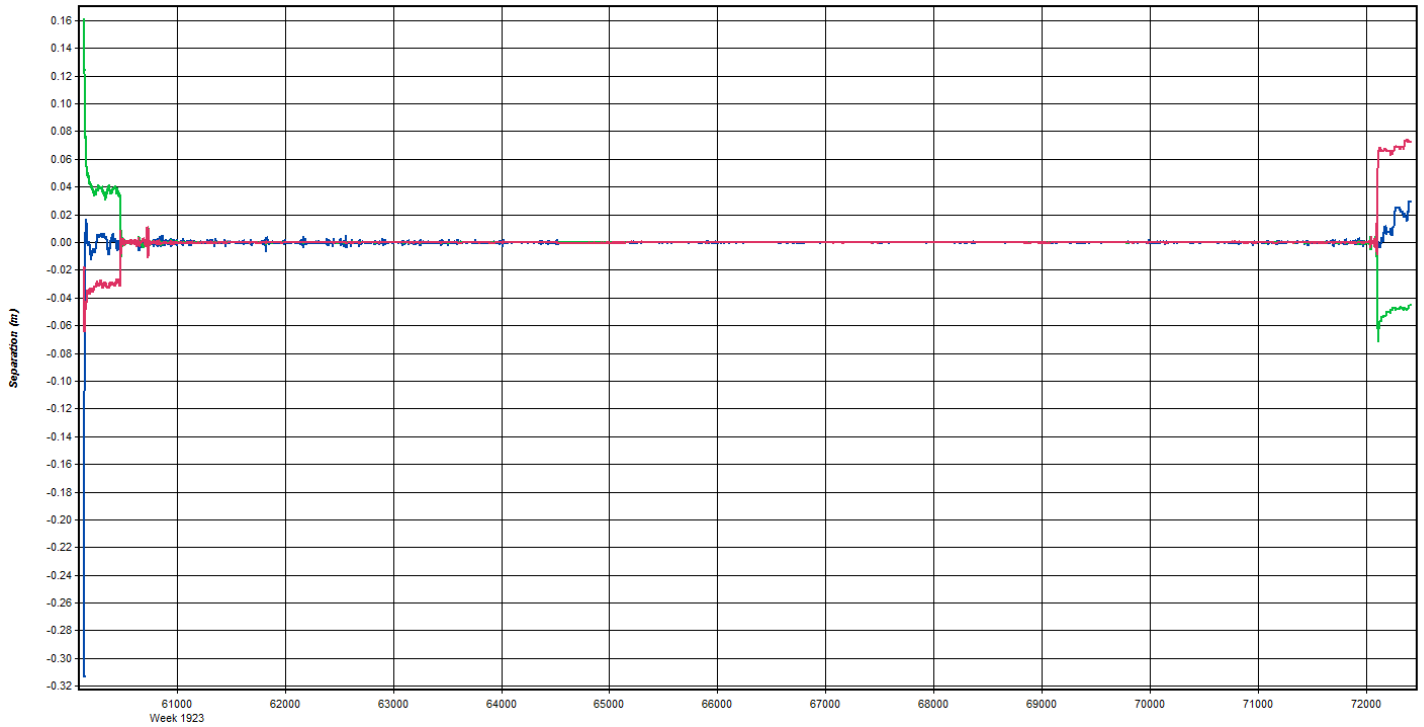

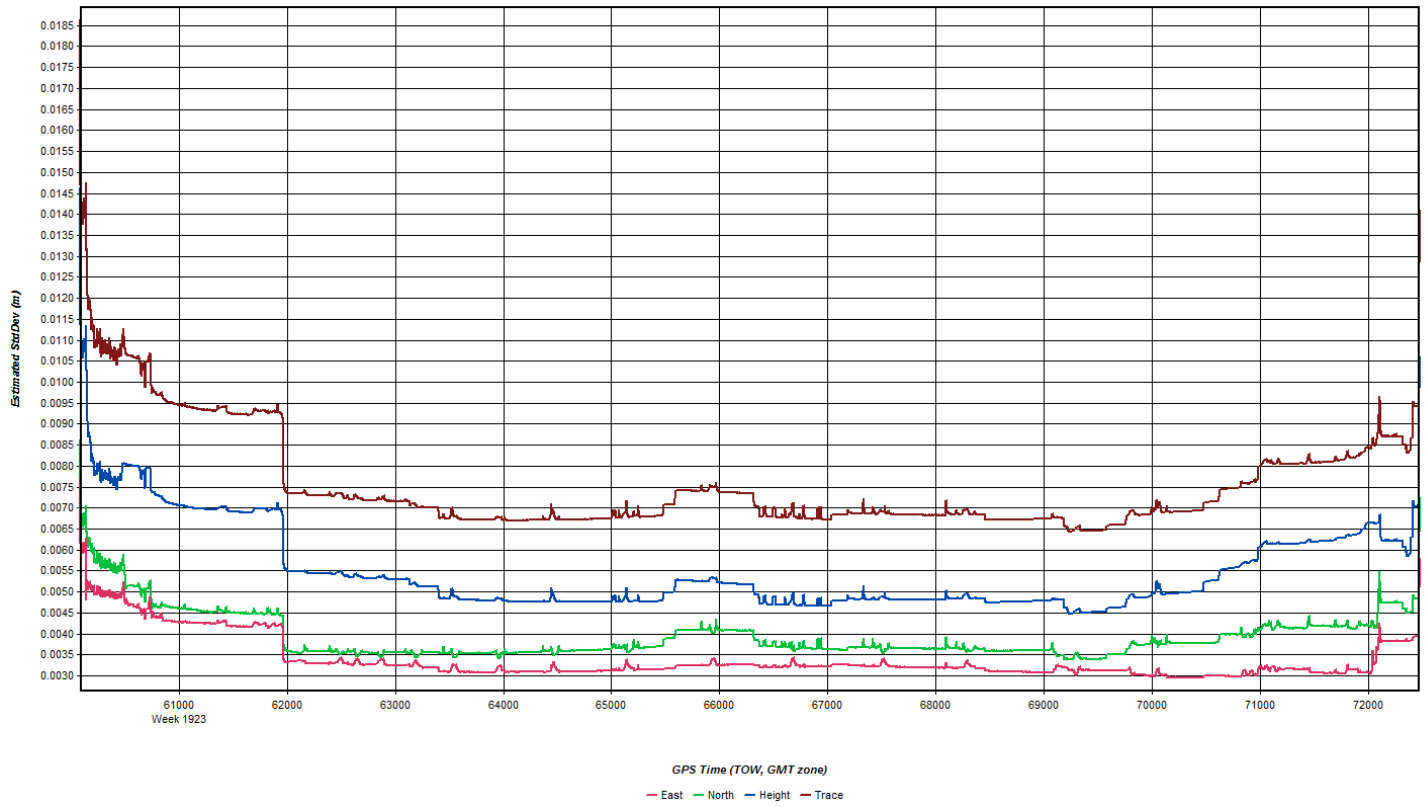
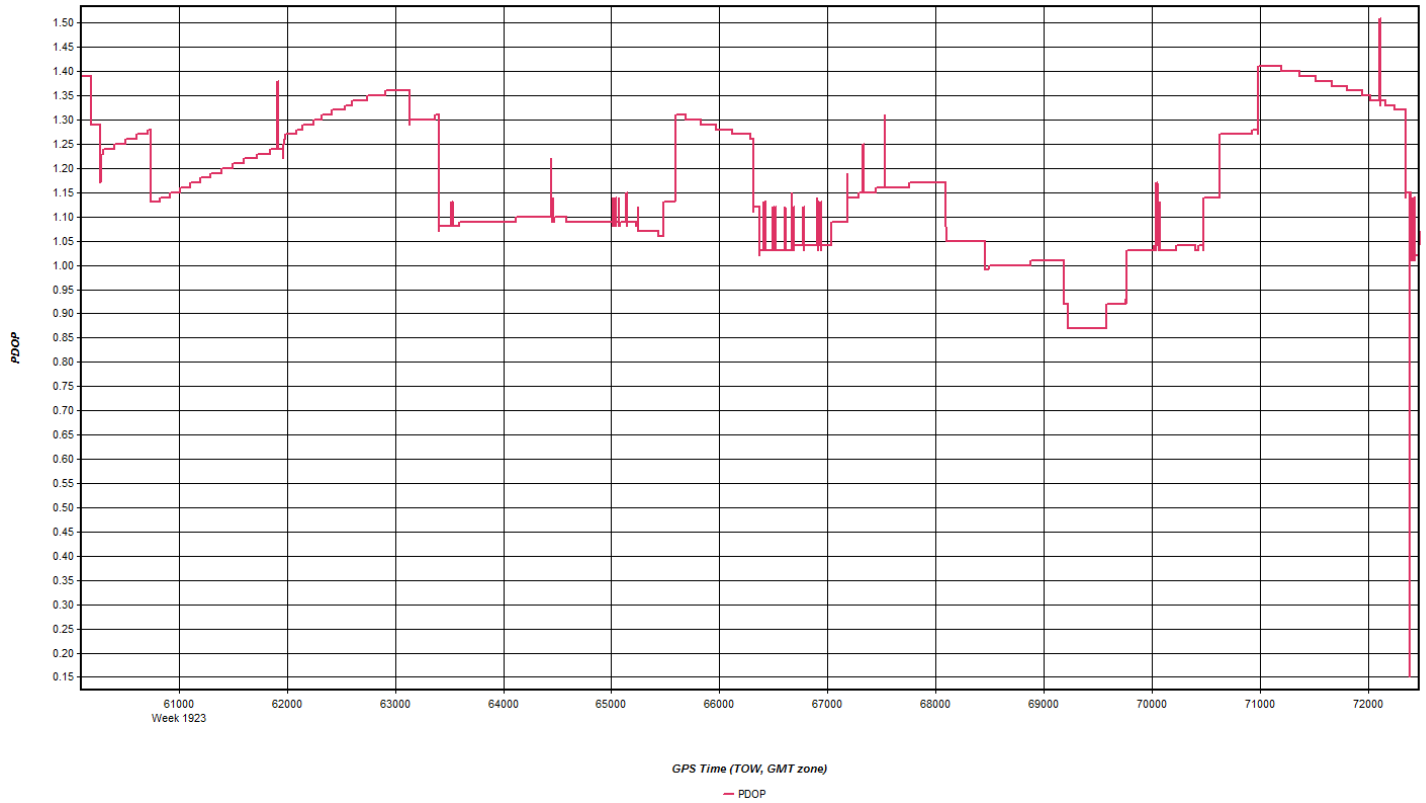

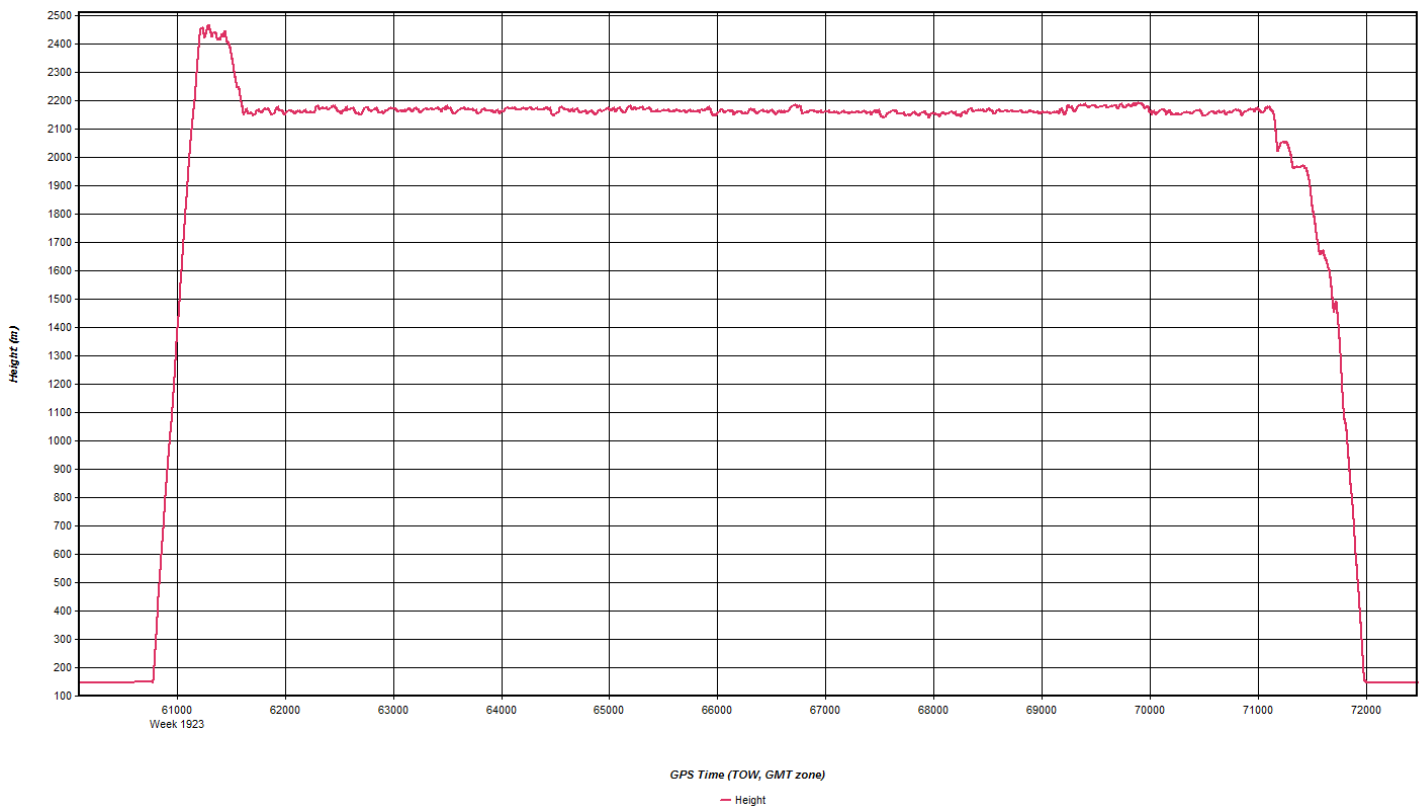
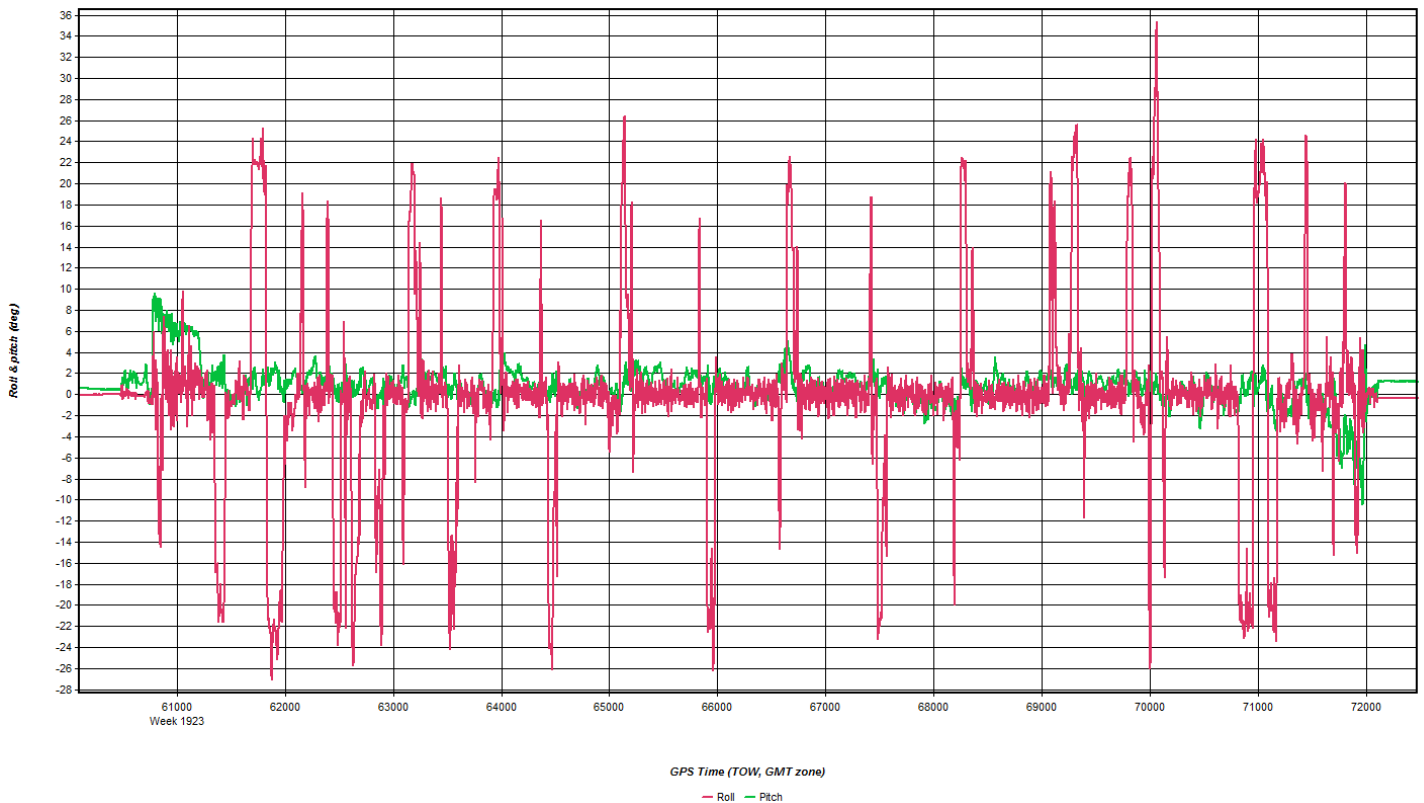

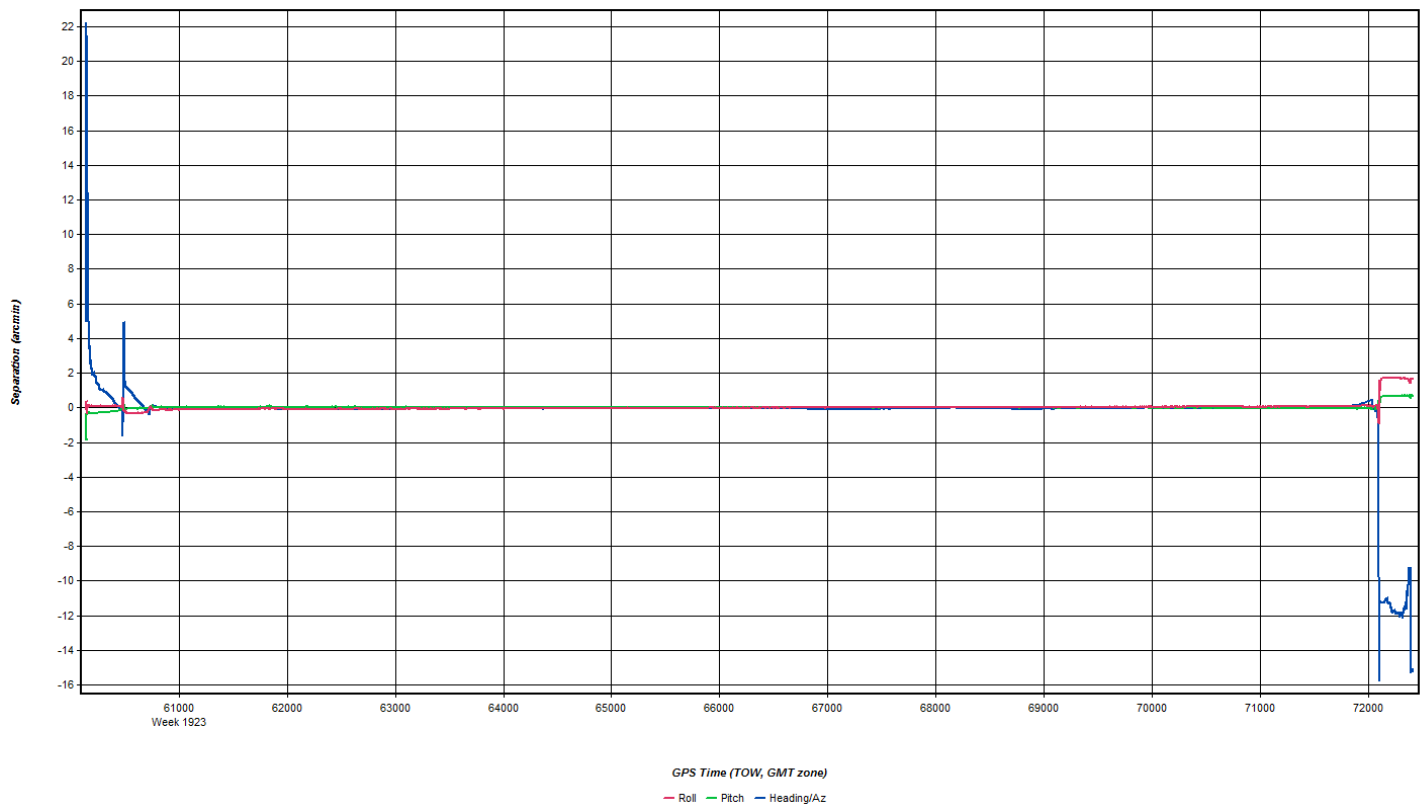
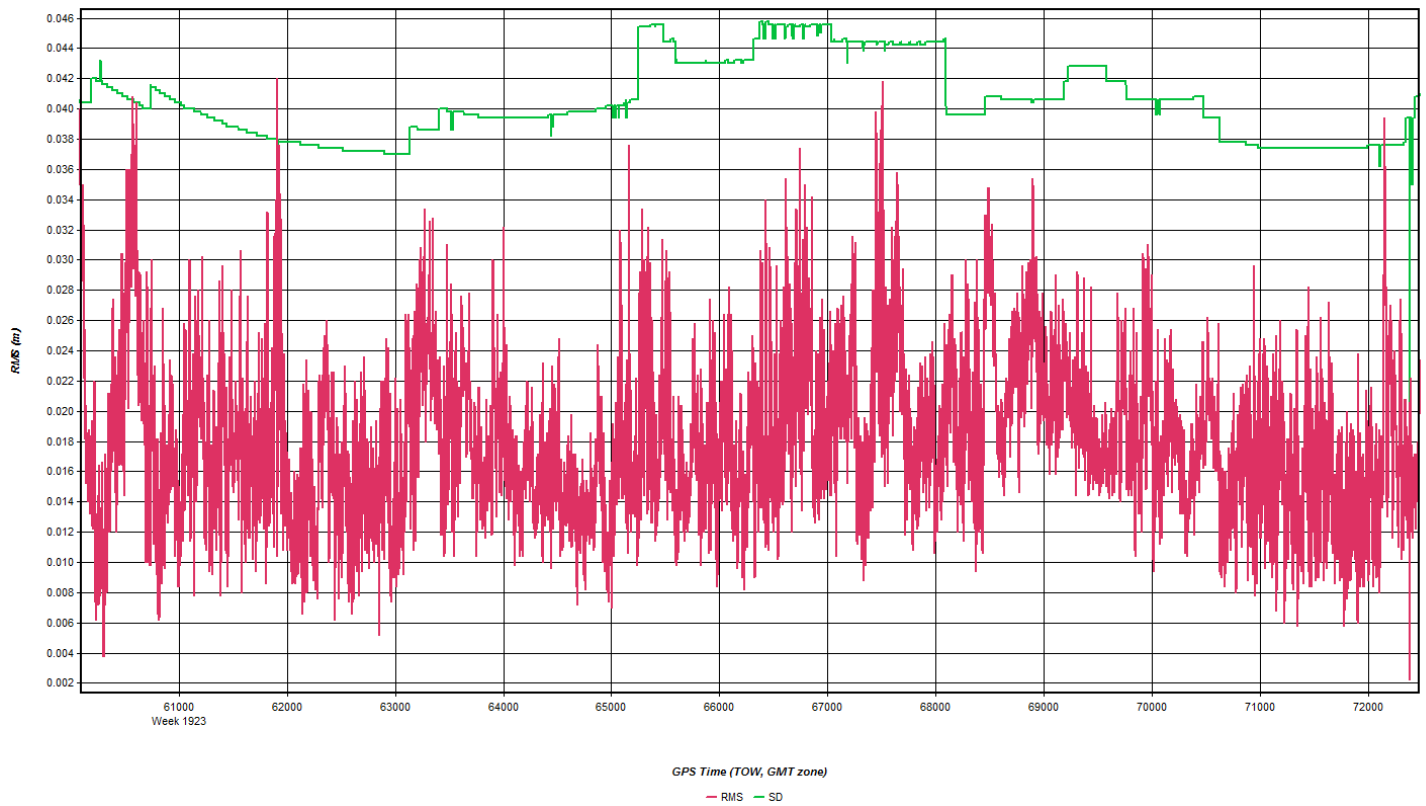

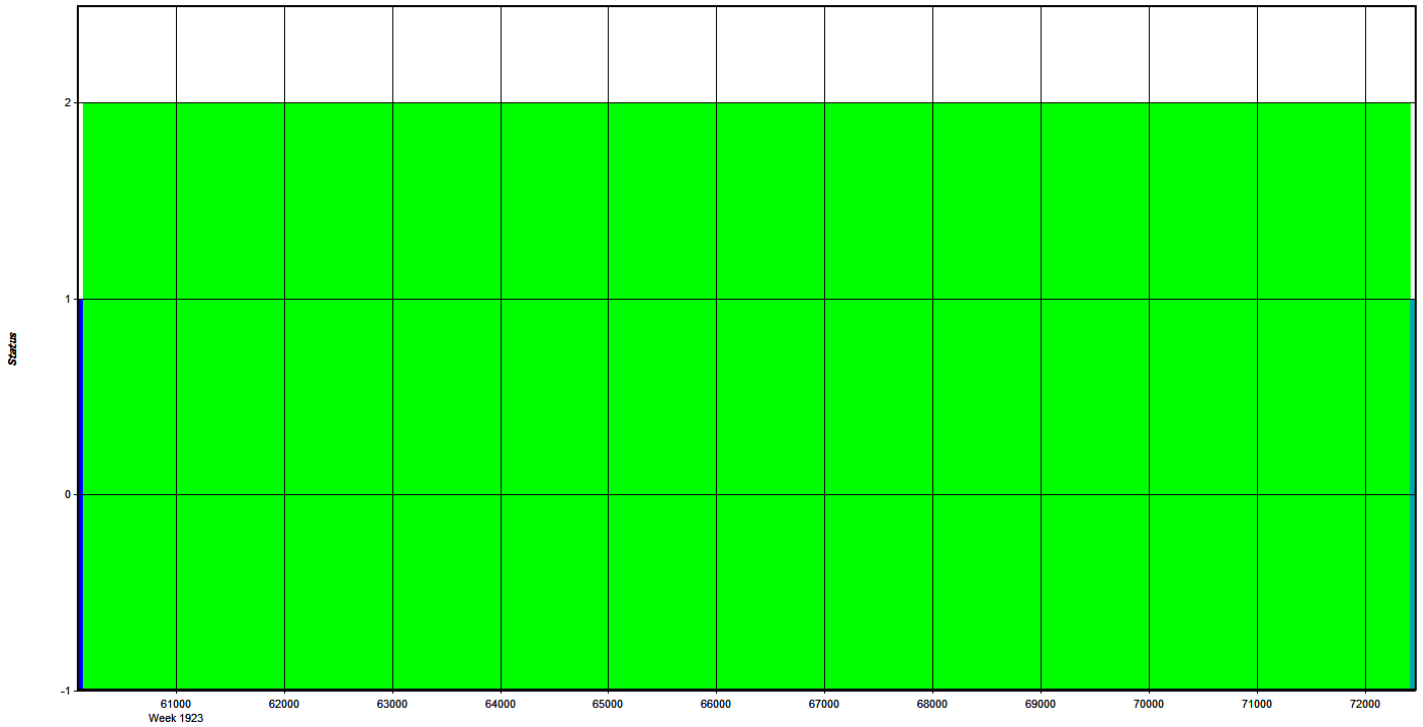

GPS Time (TOW, GMT zone)
 - Float - Forward Fixed - Reverse Fixed - Fixed (2 or more)

Coordinate/Antenna Settings

Master Remote

Base Station
 1: VTSP Name: VTSP Disabled
 File: E:\Proc\29178_CT_River\29178_ALS70_N22GE\20161113_163

Coordinates
 Latitude: North 43 16 53.24114 Compute from PPP
 Longitude: West 72 28 39.23841 Enter Grid Values
 Ellipsoidal height: 156.441 m Enter MSL Height
 Datum: WGS84 Datum Options
 Select From Favorites Add To Favorites Use Average Position

Antenna Height
 From station file: TRM55971.00, NONE View STA File
 Antenna profile: TRM55971.00 Info
 Measured height: 0.000 m
 ARP to L1 offset: 0.067 m
 Applied height: 0.067 m
 Measured to
 ARP
 L1 Phase Centre
 Compute From Slant

OK Cancel

Flight Log

Scanned by CamScanner

11-13-16 B 29178

Q Airborne LIDAR Data Collection Log Sheet :: Quantum Spatial, Inc
(email Log daily to flight_log_distribution_list@quantumspatial.com)

Date: 11-13-16 Page 2 of 2

Project: CT River VT Flight Mgmt File: 2.161113-163625

Altitude: N22GE Begin Hobbs: 8963.1 End Hobbs: 8966.2 Total: 3.1 Pilot: Tradtke Co-Pilot: Swan

Dep Apt: KLEB Dep Time (Local): 1502 (Z): TS Air Apt: KLEB Arr Time (Local): 1502 (Z): TS Tot Time Aloft: 3:2

CORS: Y N Sta 1: VTSP 1700 / 1950 Sta 2: _____

GPS Unit: Y N Sta 1: _____ Sta 2: _____

Flyovers: Y N If Y, times: Sta 1 _____ Sta 2 _____

Gd Temp beg: _____ °C End: _____ °C OAT beg: TY °C End: TS °C Altimeter begin: 2998 end: 2992

LIDAR	Type	Serial #	Alt AGL	Alt ANSL	MPIA	Y	N	Avg Pt Spacing	Max Gdspd	Power	PPSM	Storage Name/ID
	FOV	40	711		53			100				127
												99
												017

Line #	Hdg	Start (UTC)	End (UTC)	Gd Spd	Foot/Min	GPS Altitude	Crab	Turb	Notes
		1652	1700						
		1708	1714						
1955	0	1717	1719	155	1.2/17	7108	5°	0	LEB -> VTSP
1054	180	1729	1731	161	1.2/17	7139	29°	0	Fig 3's
1053	0	1735	1737	127	1.1/18	7128	2°	0	Holds time = 3.1
1052	180	1740	1742	169	1.1/18	7125	29°	0	B & ONLINE time = 2.4
1051	0	1748	1752	129	1.4/17	7130	12°	0	Mob time = 0.7
1050	180	1755	1802	160	1.1/17	7140	15°	0	113 A/B
1049	0	1807	1817	138	1.2/16	7112	12°	0	4.665 = 5.7
1048	180	1820	1829	147	1.0/18	7107	12°	0	ONLINE = 4.3
1047	0	1832	1842	160	1.1/17	7074	9°	0	total mob = 1.4
1046	180	1846	1855	162	1.1/17	7077	11°	0	speed increased to 178 high winds
1045	0	1900	1910	149	1.4/19	7084	12°	0	X tie planned
1044	180	1917	1921	138	1.1/18	7132	7°	0	Strong tail wind 170-165
		1929	1929	170	1.1/18	7044	12°	0	side -> VTSP (Fig 3's 1940-1946) (VTSP 1950)
		1940							Landed KLEB

Total Prof Lines: _____ Lines Flow: 13 Lines Remain: _____ Online Time: 2.4 Mob Time: 0.7 Notes: _____

Nov 13, 2016-B (N73TM, SN7178)

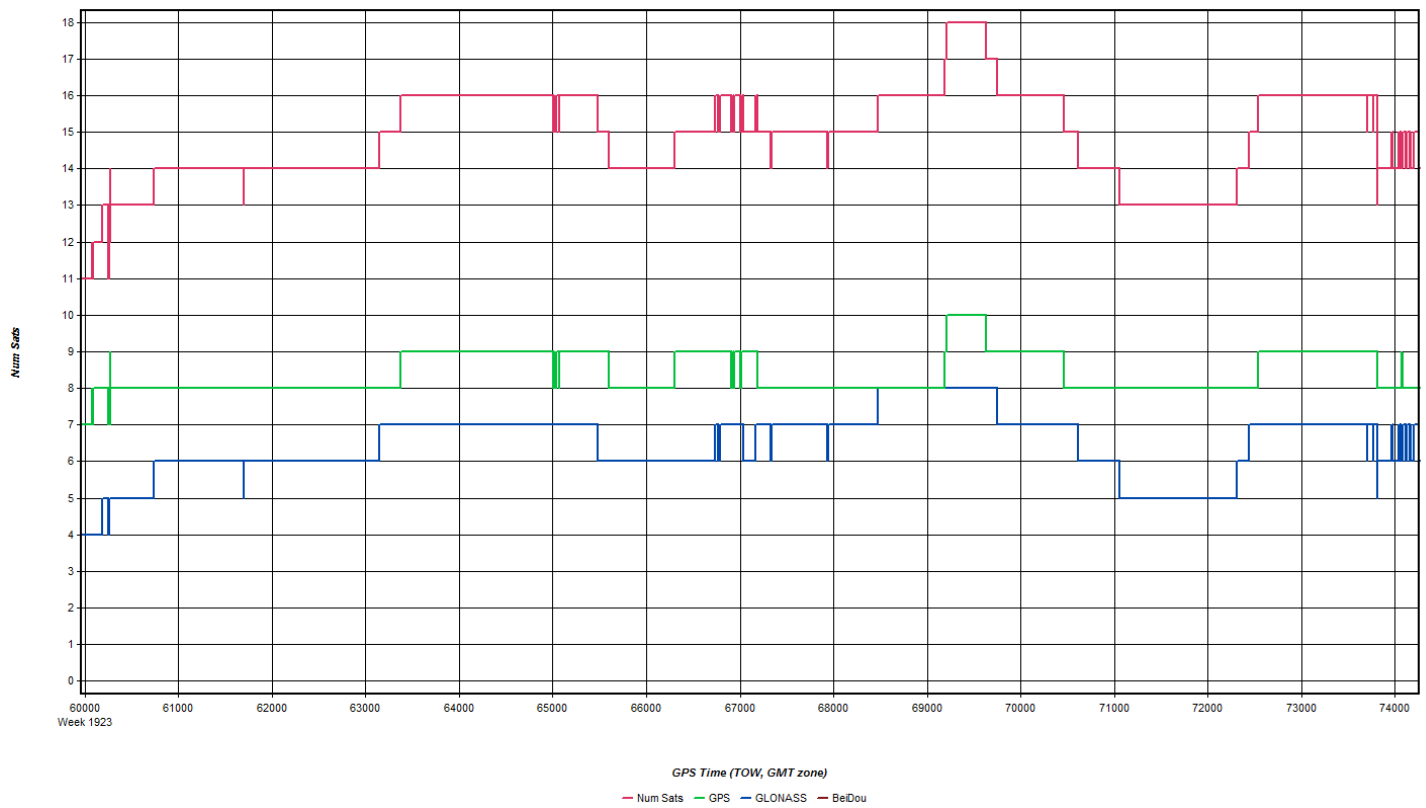
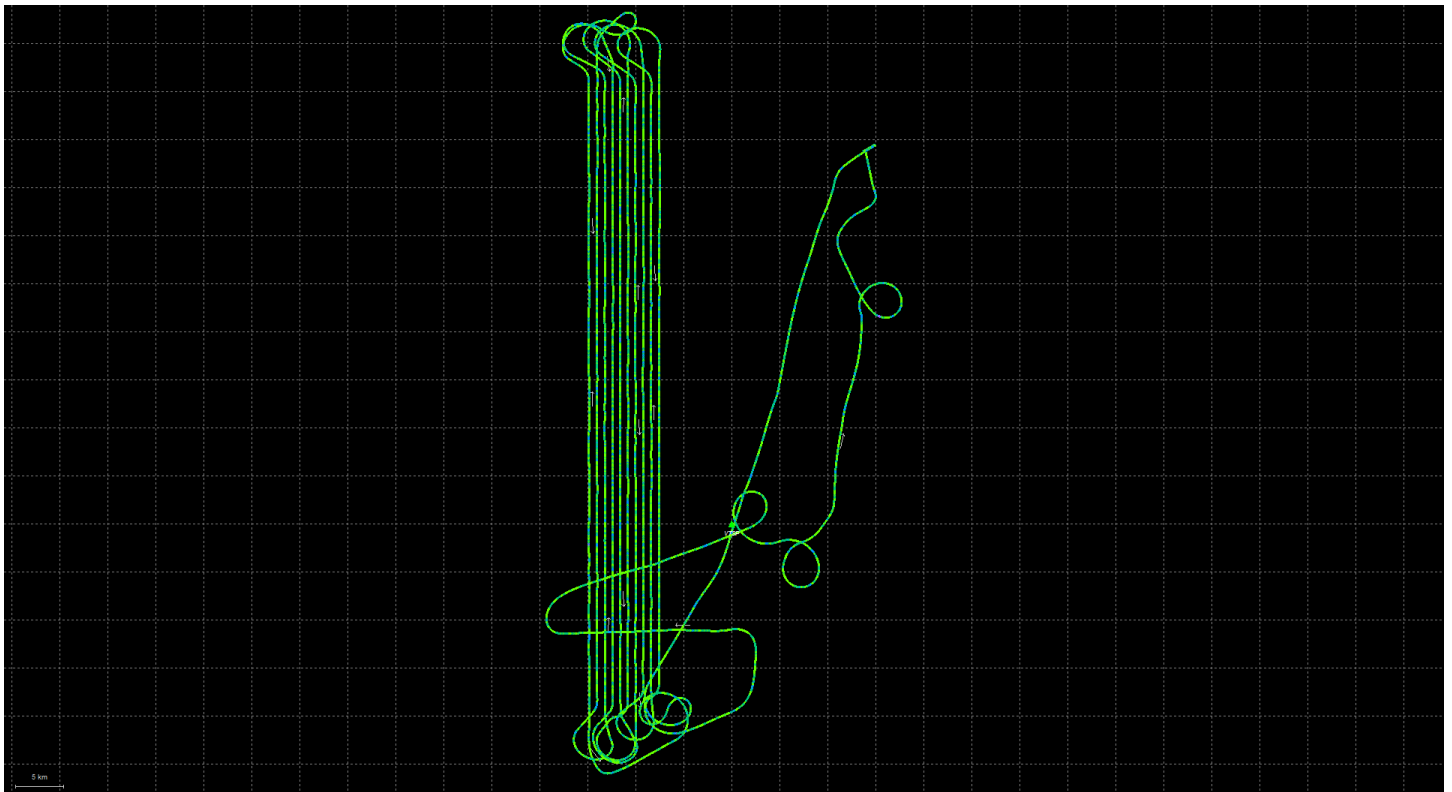

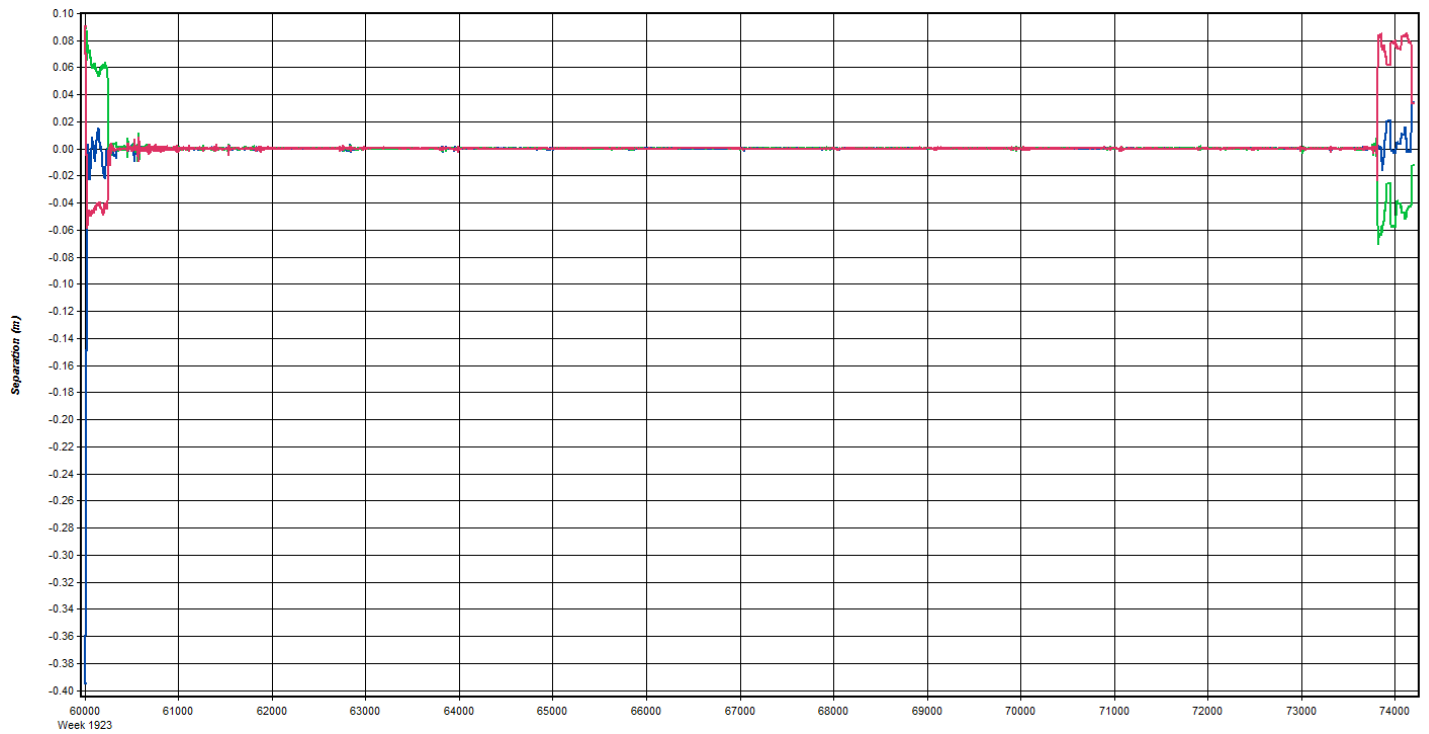

GPS Time (TOW, GMT zone)

— East — North — Up

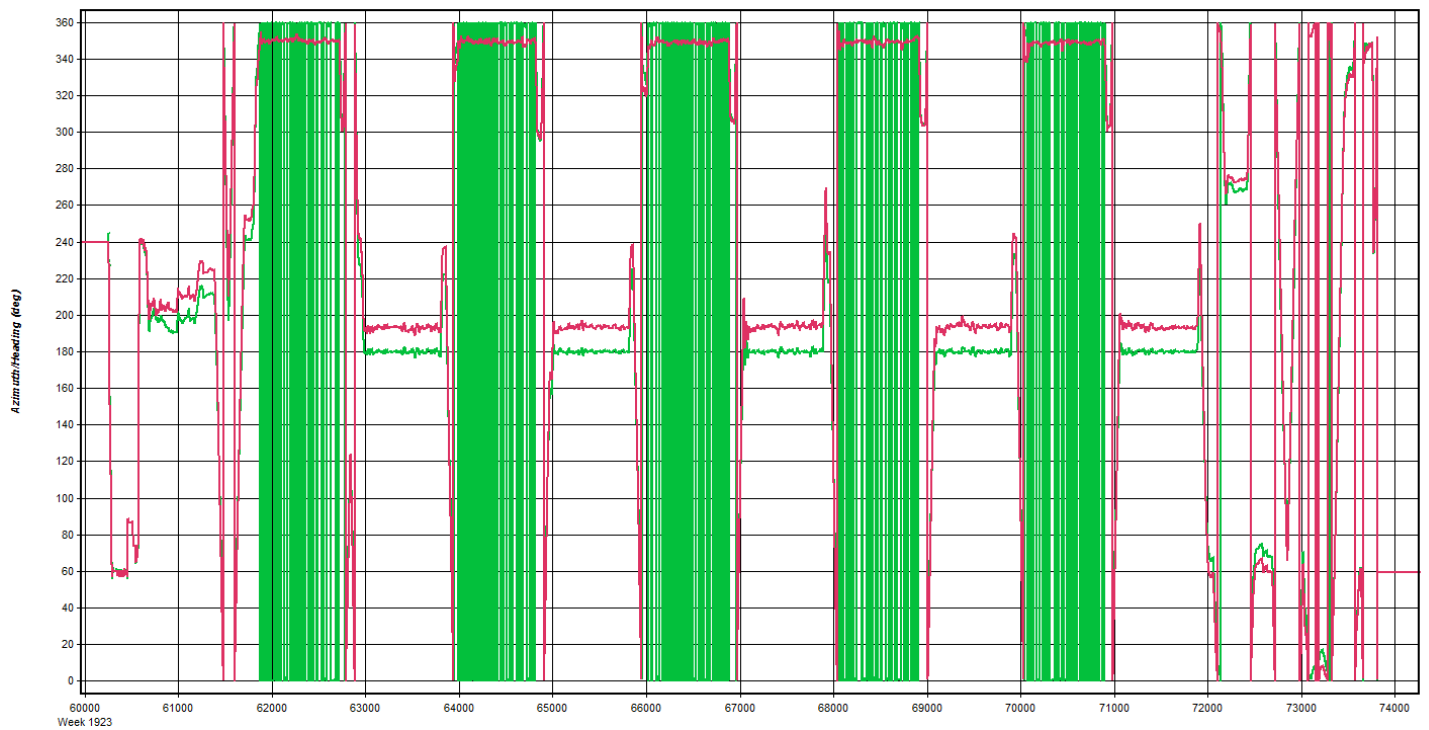

GPS Time (TOW, GMT zone)

— Heading/Azimuth — GPS-COG

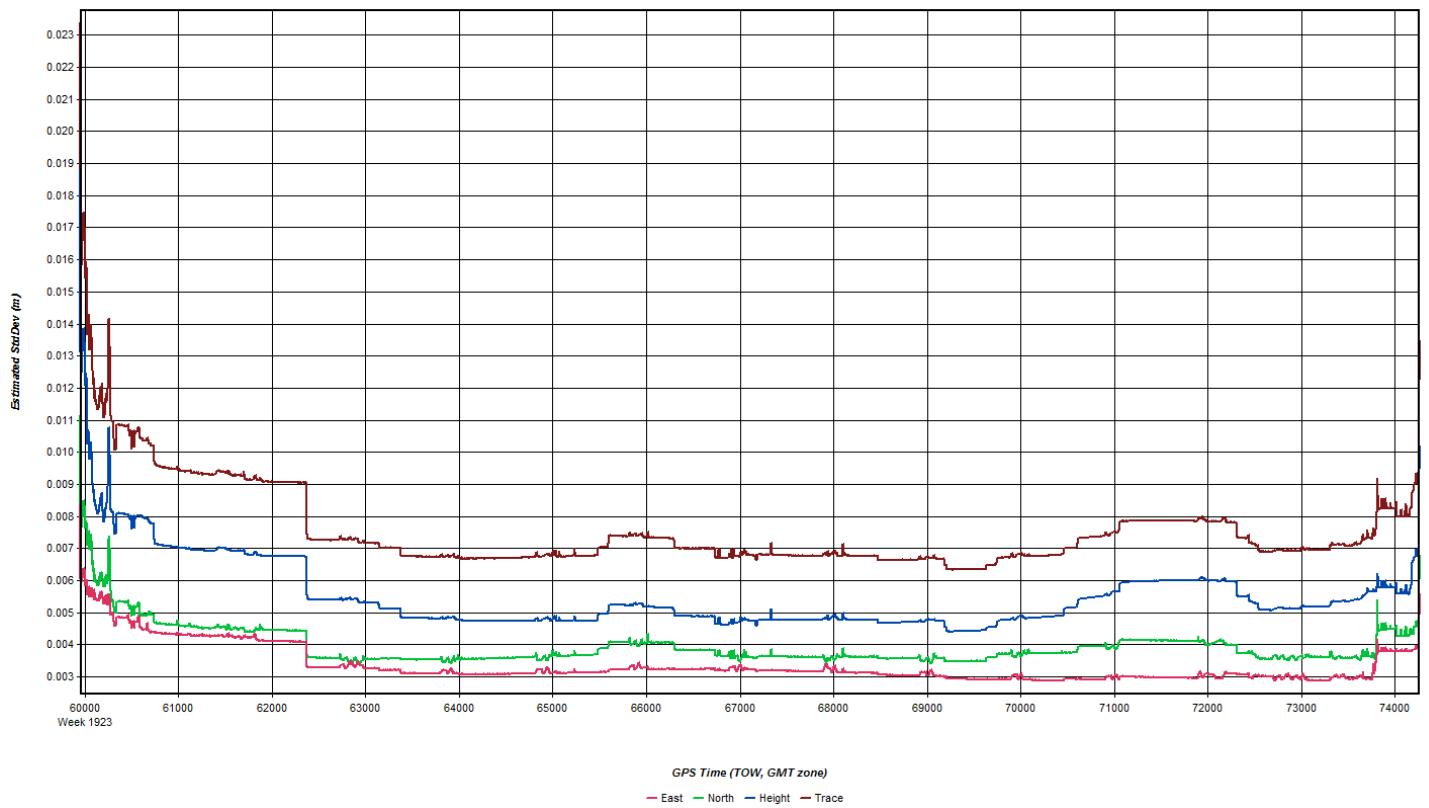
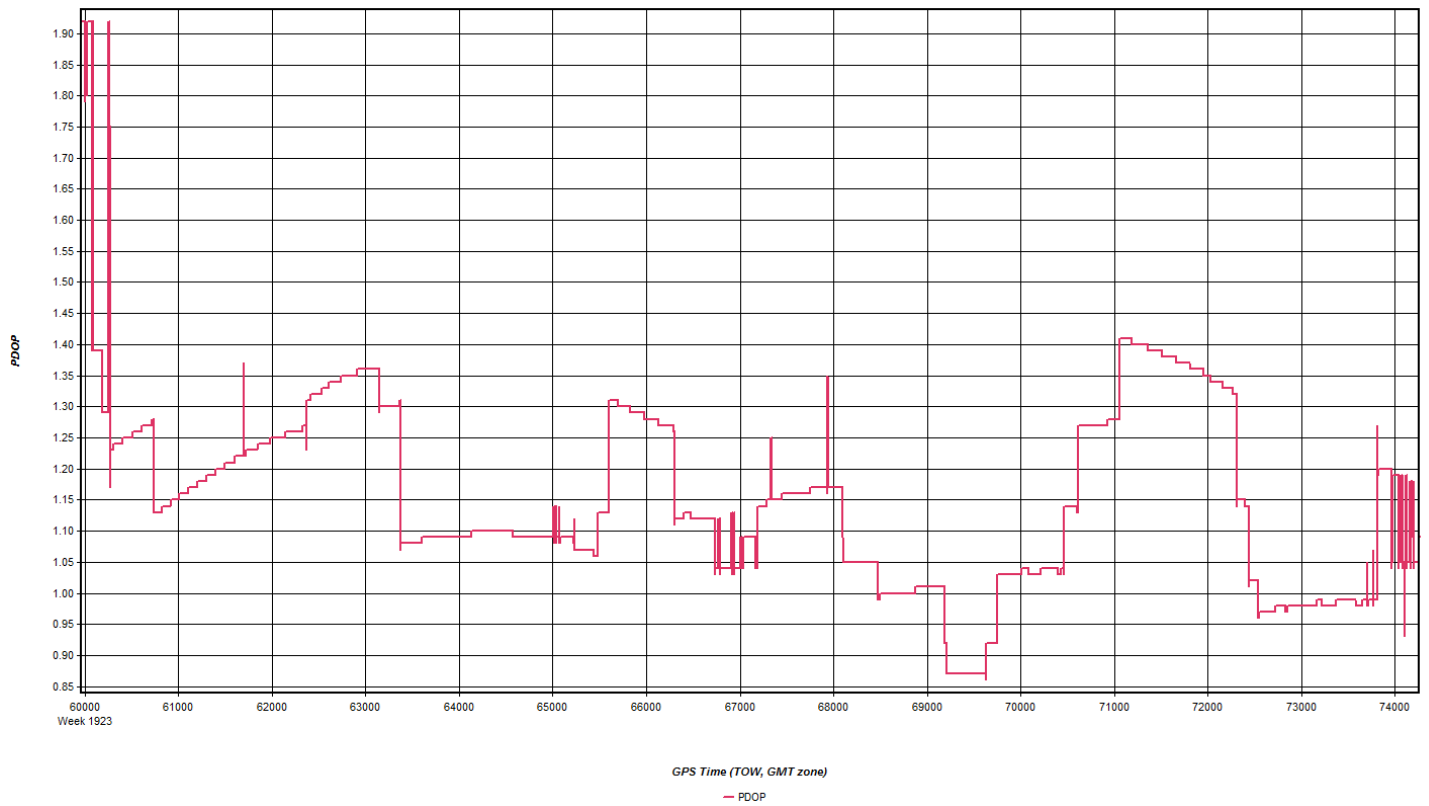

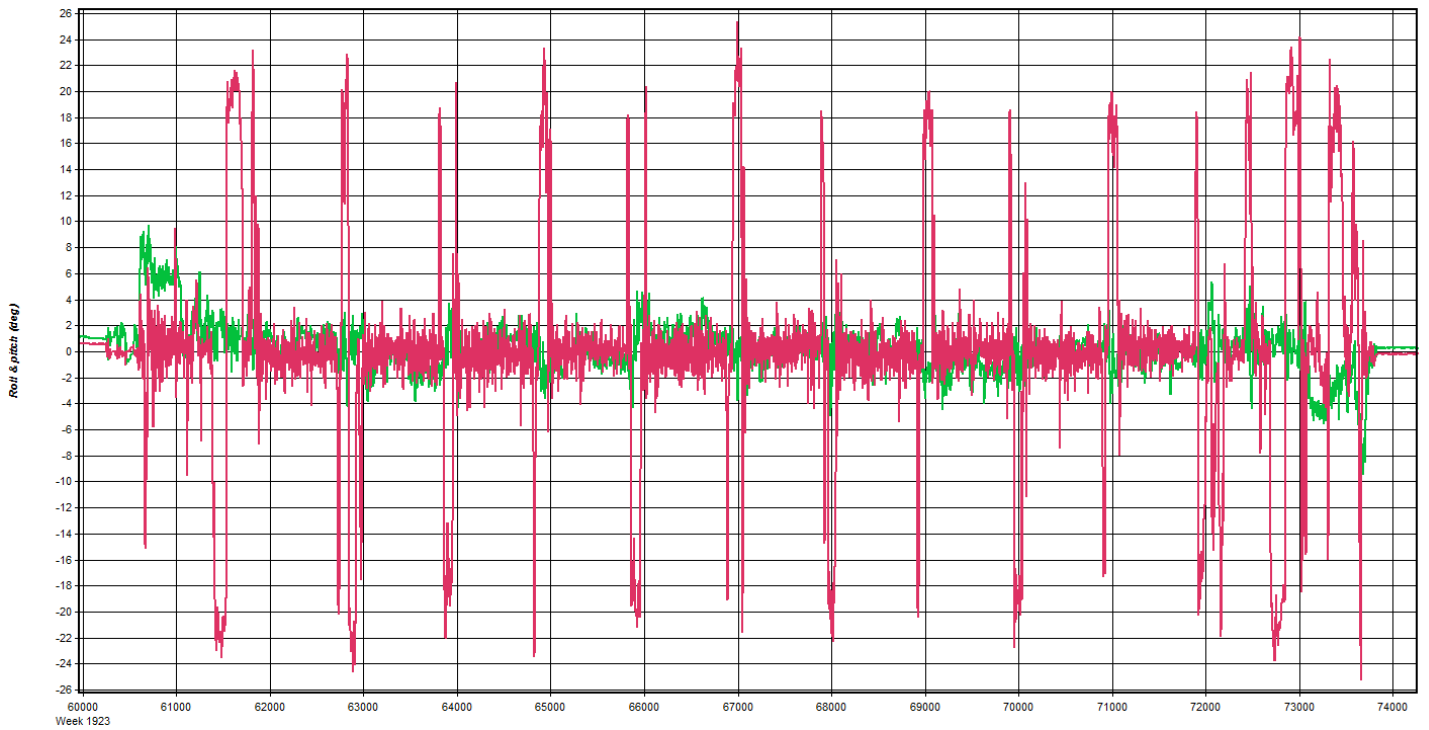

GPS Time (TOW, GMT zone)

— Roll — Pitch

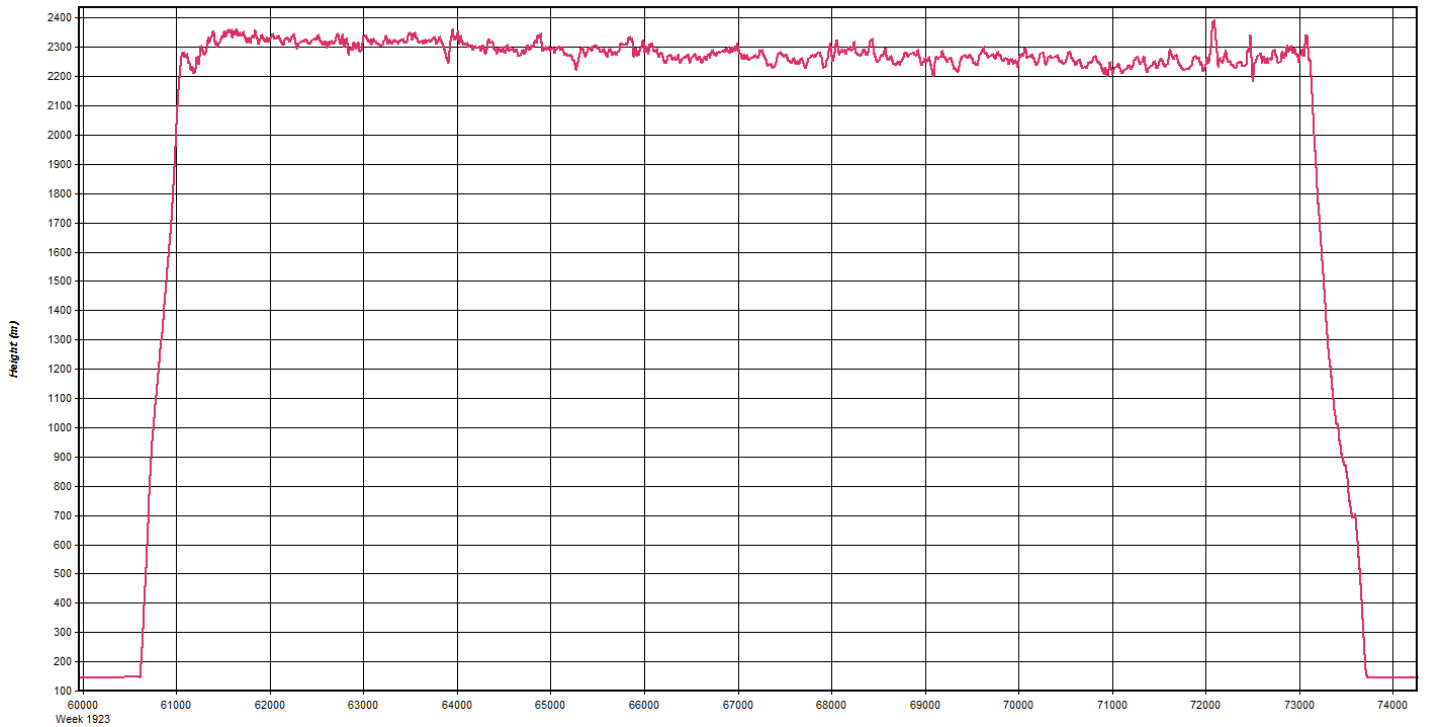

GPS Time (TOW, GMT zone)

— Height

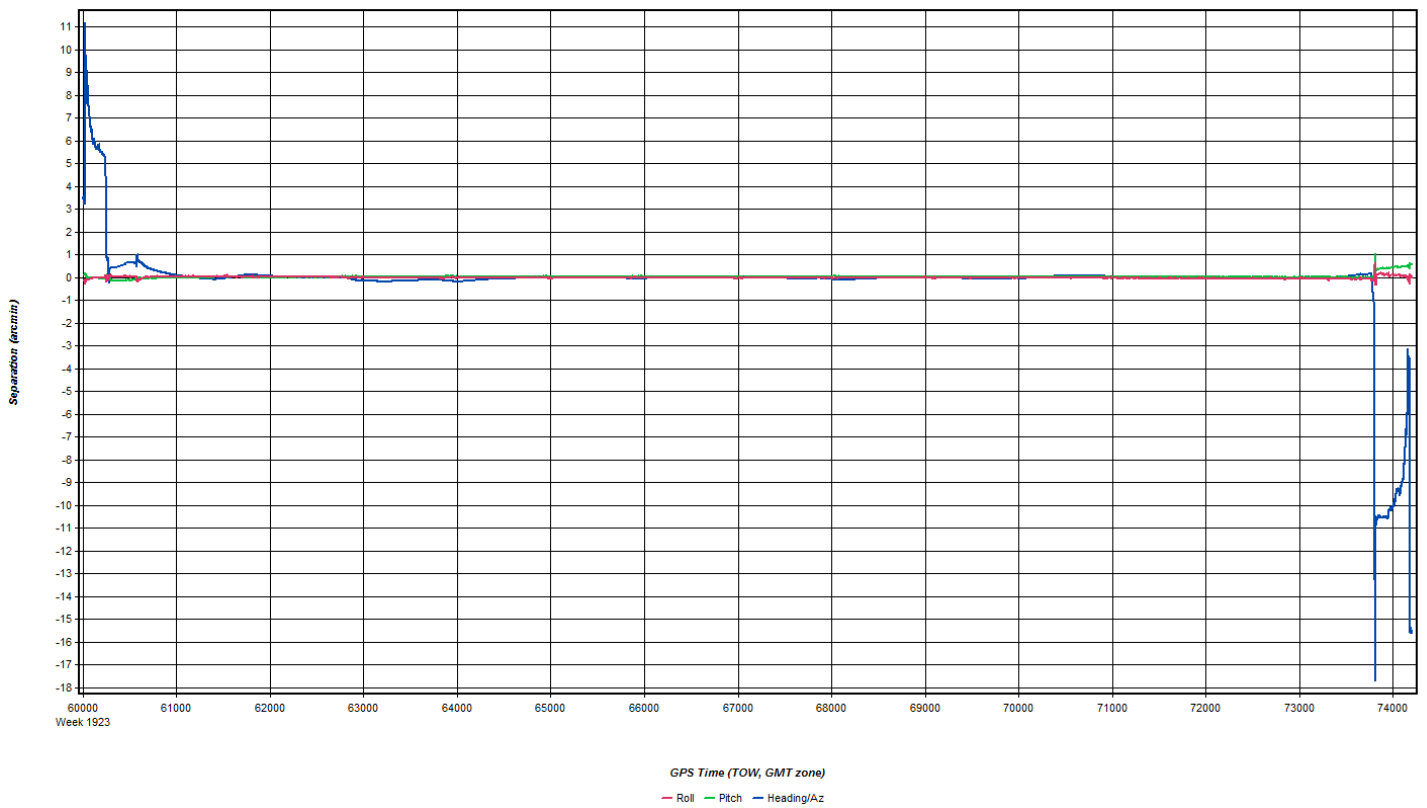
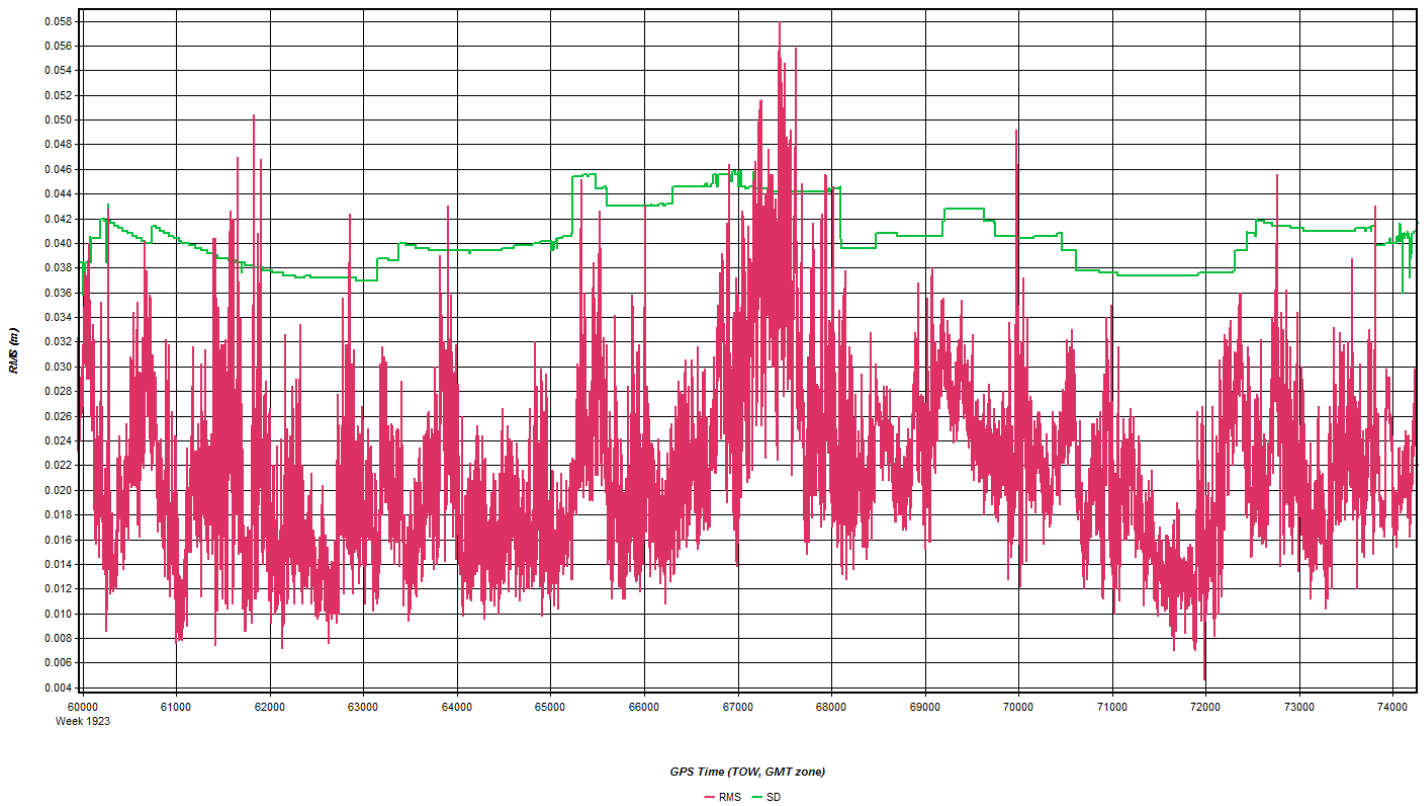

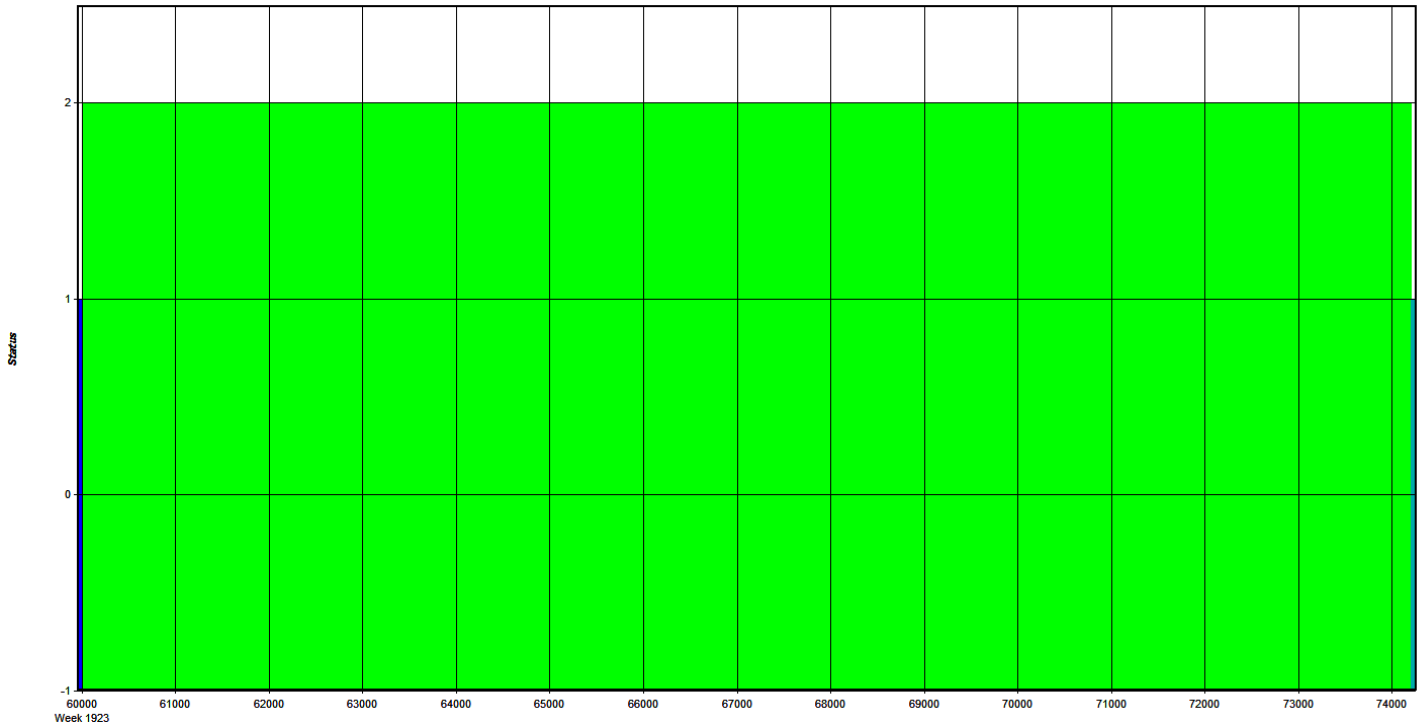

GPS Time (TOW, GMT zone)
 - Float - Forward Fixed - Reverse Fixed - Fixed (2 or more)

Coordinate/Antenna Settings

Master Remote

Base Station
 1: VTSP Name: VTSP Disabled
 File: E:\Proc\29178_VT_CT_River_Basin\From_M_Aust_11-15-16\201

Coordinates
 Latitude: North 43 16 53.24114 Compute from PPP
 Longitude: West 72 28 39.23841 Enter Grid Values
 Ellipsoidal height: 156.441 m Enter MSL Height
 Datum: WGS84 Datum Options
 Select From Favorites Add To Favorites Use Average Position

Antenna Height
 From station file: TRM55971.00, NONE View STA File
 Antenna profile: TRM55971.00 Info
 Measured height: 0.000 m
 ARP to L1 offset: 0.067 m
 Applied height: 0.067 m
 Measured to:
 ARP
 L1 Phase Centre
 Compute From Slant

OK Cancel

Flight Log

Date: 11-13-16

Lift: (A) (B) (C) (D) (E)

Pg 7 of 7

Quantum Spatial

Airborne LIDAR Data Collection Log Sheet :: Quantum Spatial, Inc

(email log daily to flight_log_distribution_list@quantumspatial.com)

Project: USGS MT RIVER LIDAR

Project #: 29178

Flight Mgmt File:

Tech: M Aust

Pilot: J Barham

Co-Pilot:

Aircraft: 737M

Begin Hobbs: 6495.7

End Hobbs: 6499.3

Total: 3.6

Dep Apt: LEB

Arr Apt: LEB

Arr Time (Local): 3:30 (Z): 2030

Tot Time Aloft: 3.75

CORS: (Y) N

Sta 1: VTSP

Sta 2:

Flyovers: (Y) N

If Y, times: Sta1: 1659, 2010

Sta2:

GPS Unit: Y / N

Sta 1:

Sta 2:

Flyovers: Y / N

If Y, times: Sta1:

Sta2:

Gd Temp beg:	9	°C	End:	11	°C	OAT beg:	°C	End:	°C	Alt AMSL	7.5	Avg Terr Ht	Max Gdepd	Power	Altimeter begin:	3000	end:	3000	Avg Pt Spacing	PPSM	Beg CB	End CB	Tot CB	Storage Name
LIDAR																								4
	FOV	40				53																		

Line #	Hdg	Start (UTC)	End (UTC)	Gd Spd	POOP/sats	GPS Altitude	Crb	Turb (0-4)	FLIGHT LINE NOTES - visibility, clouds, smoke, partial, etc.	
									Lines Flown:	Lines Remain:
1022	N	1711	1725	155	13/16	7.6				
1023	S	1730	1743	165	11/18	7.6				
1024	N	1746	1759	152	12/17	7.6				
1025	S	1803	1816	156	12/16	7.5				
1026	N	1820	1834	139	10/18	7.6				
1027	S	1837	1851	160	11/17	7.4				
1028	N	1855	1908	152	11/18	7.5				
1029	S	1912	1924	161	11/18	7.4				
1030	N	1928	1941	152	11/18	7.4				
1031	S	1945	1958	142	12/15	7.3				
14001	W	2003	2006	151	12/16	7.4				CROSSFLIGHT

Total Proj Lines:

Lines Flown:

Lines Remain:

Online Time: 3.0

Mob Time: .75

Notes:

Nov 14, 2016-A (N22GE, SN7161)

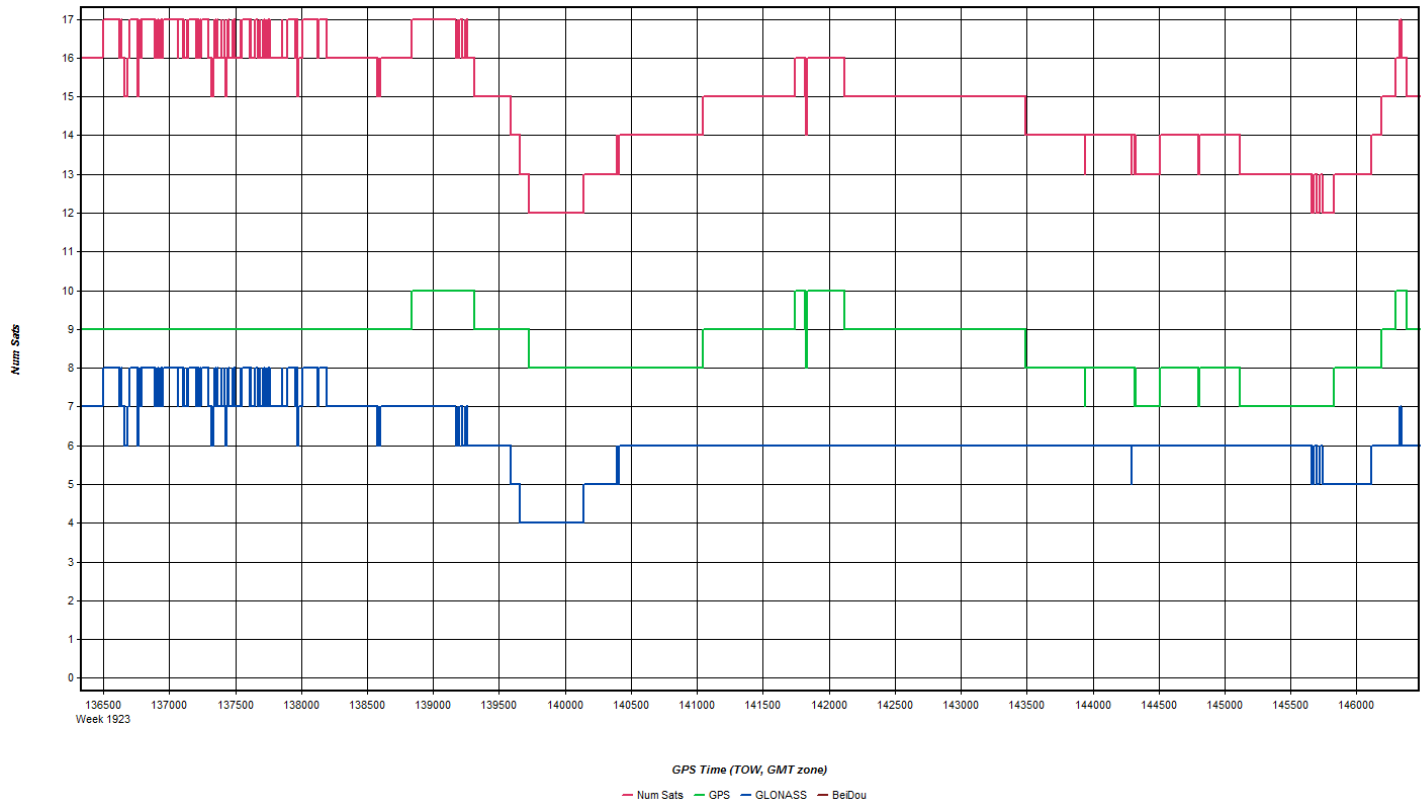
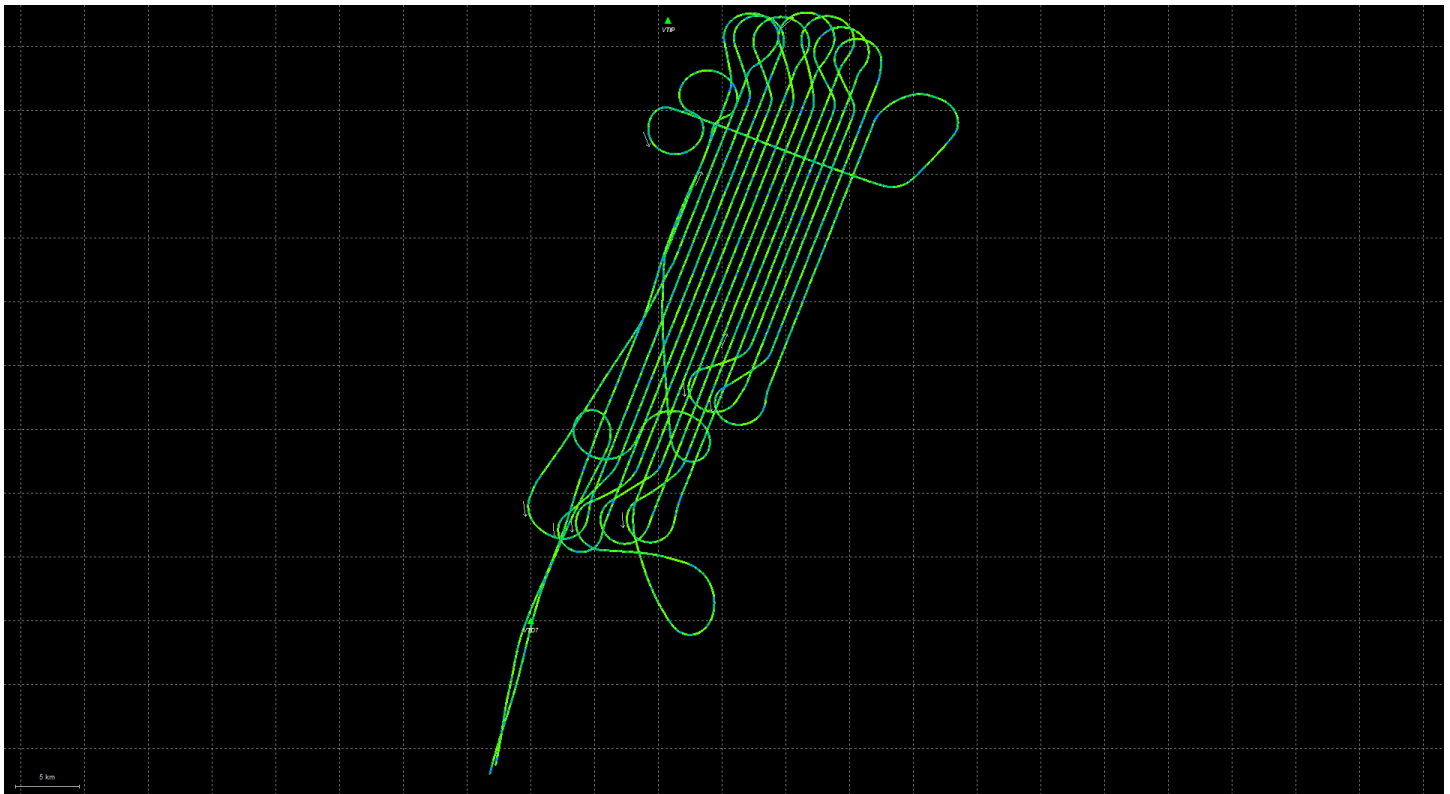

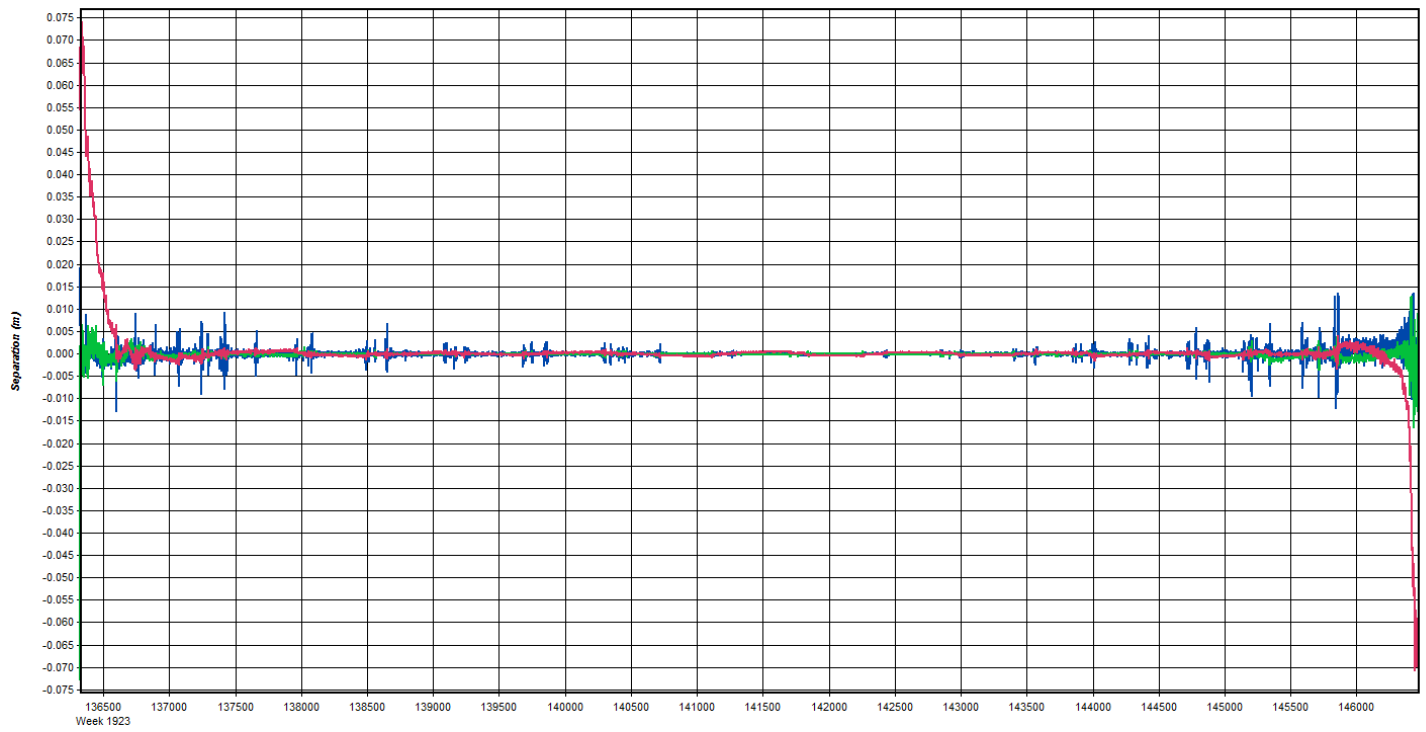

GPS Time (TOW, GMT zone)
— East — North — Up

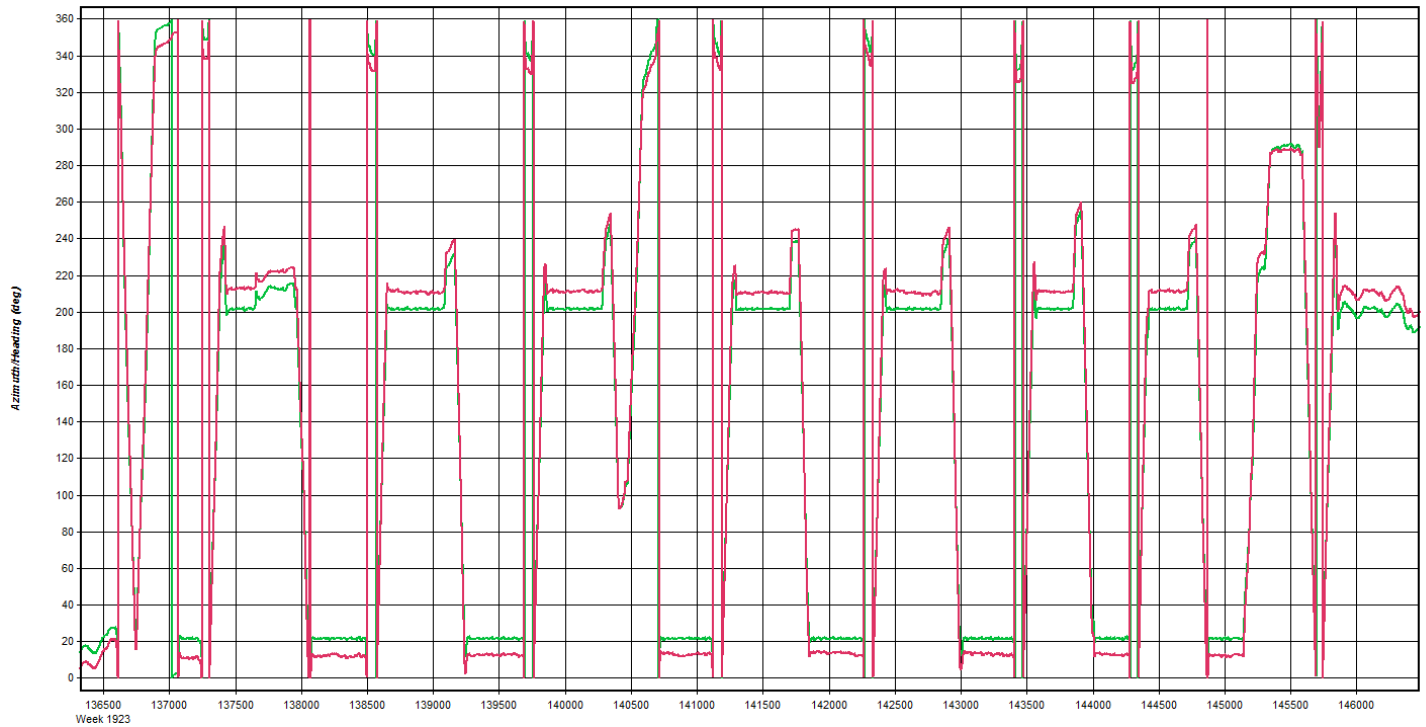

GPS Time (TOW, GMT zone)
— Heading/Azimuth — GPS-COG

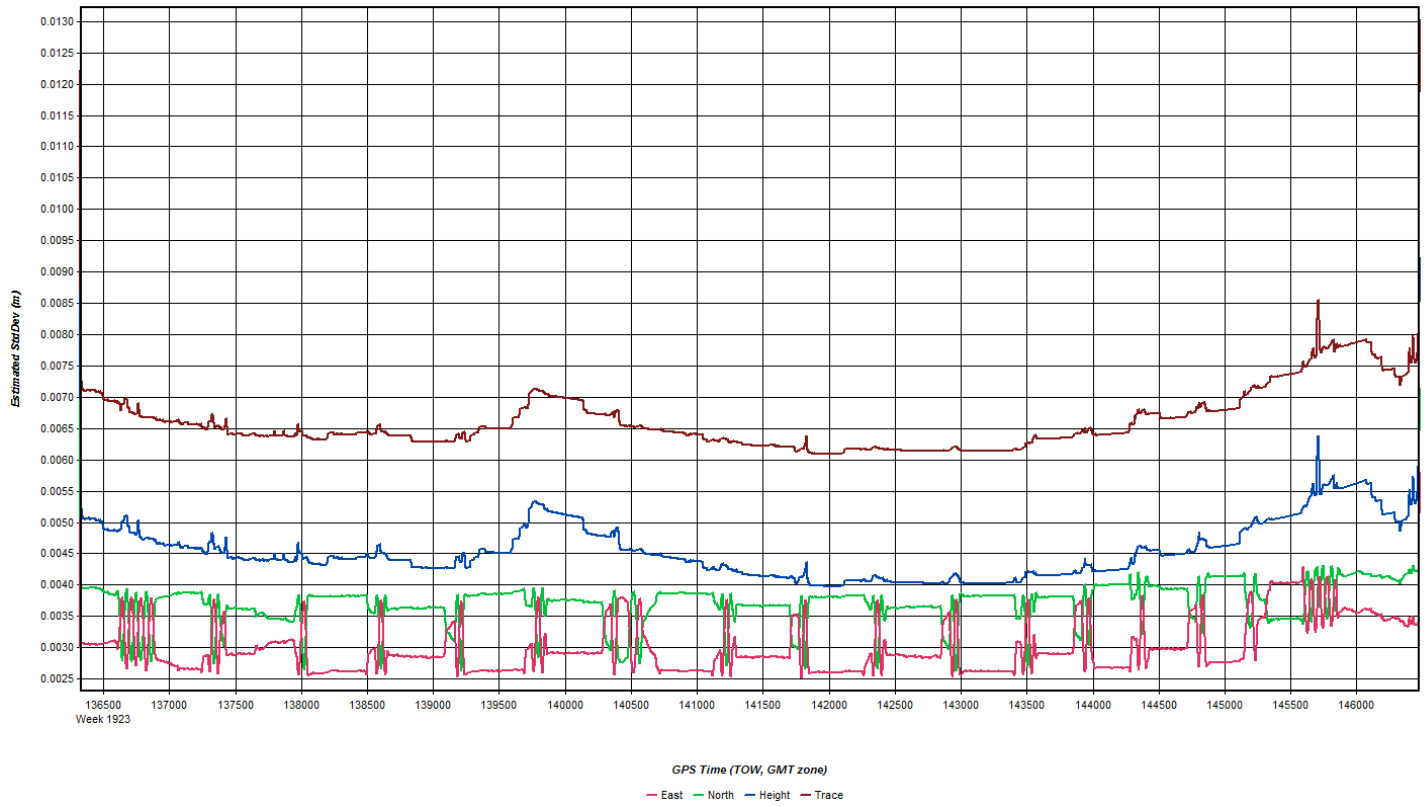
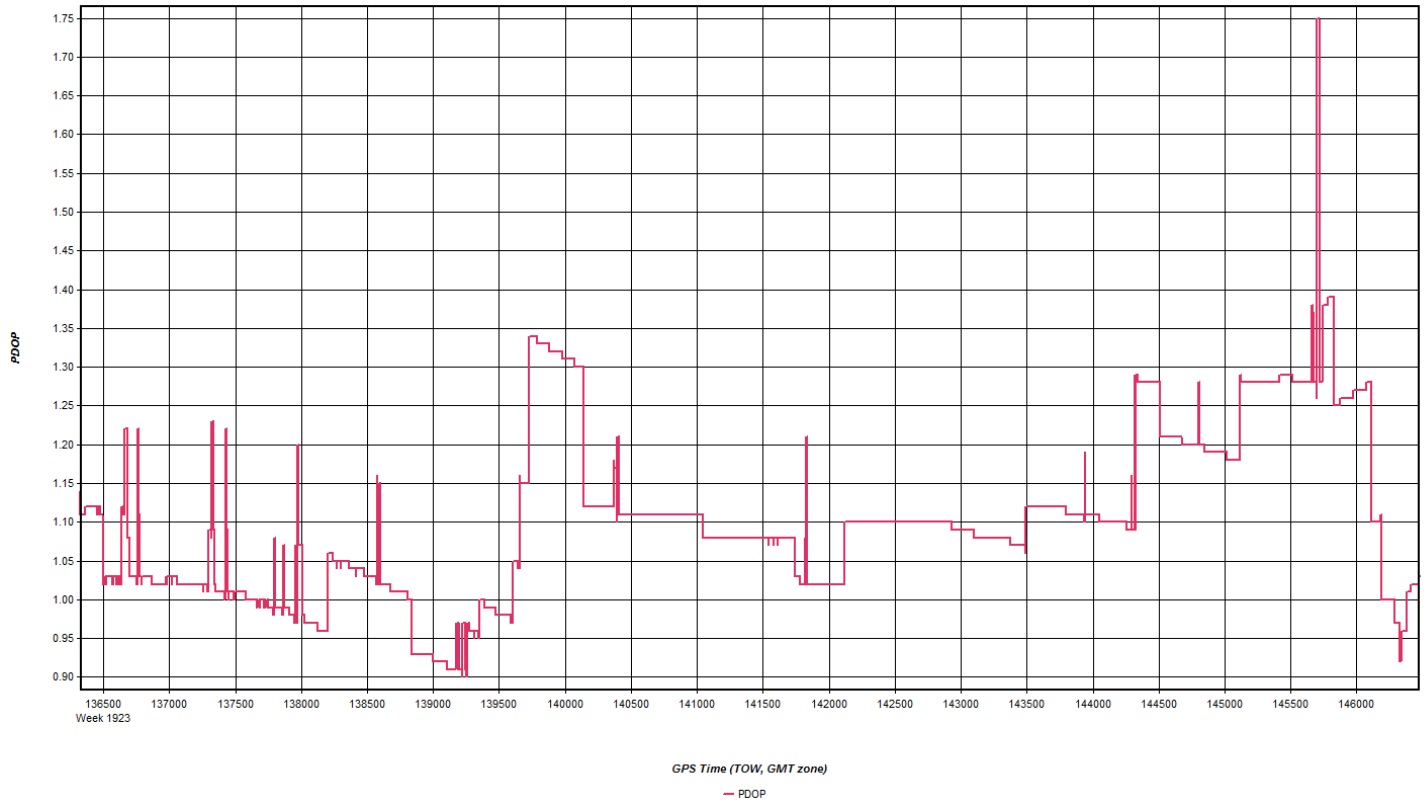

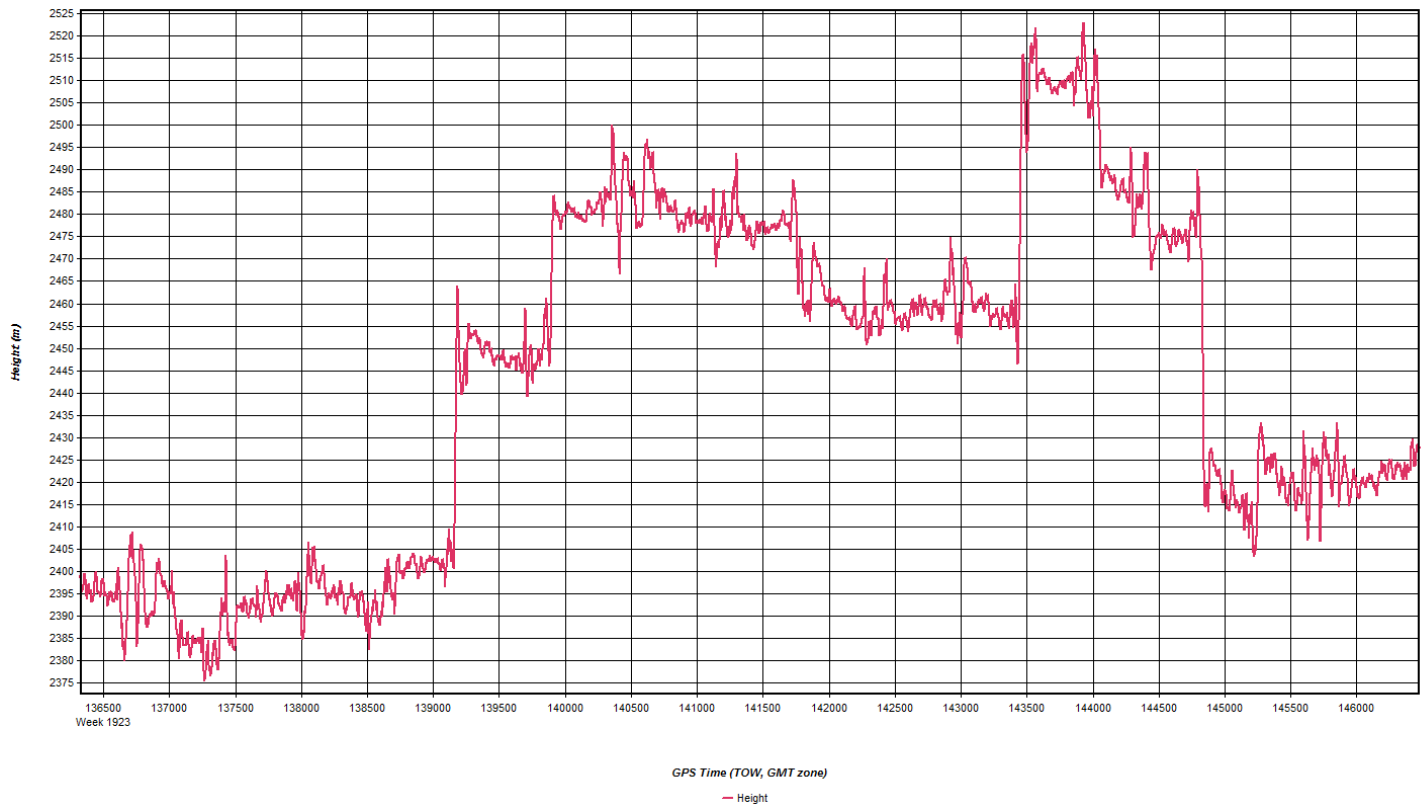
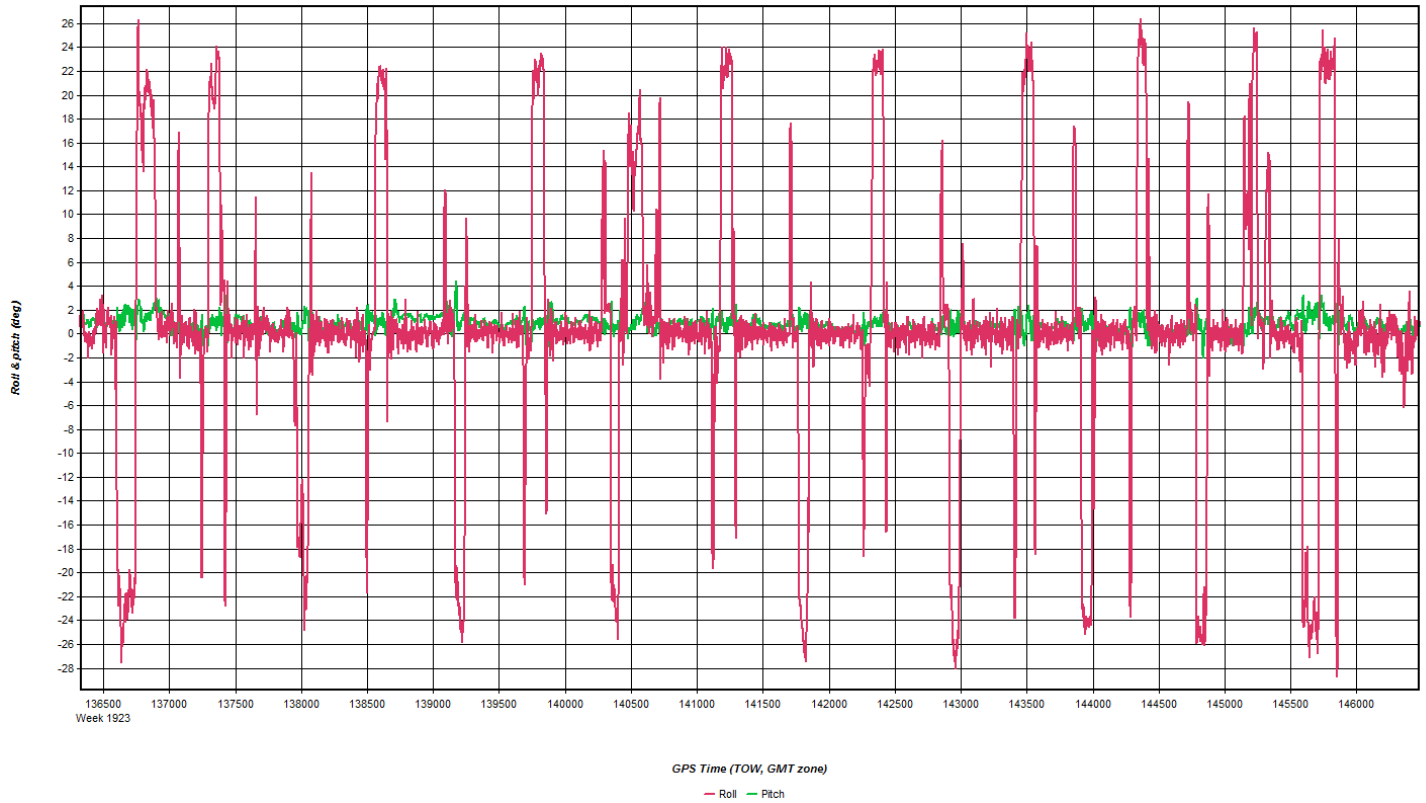

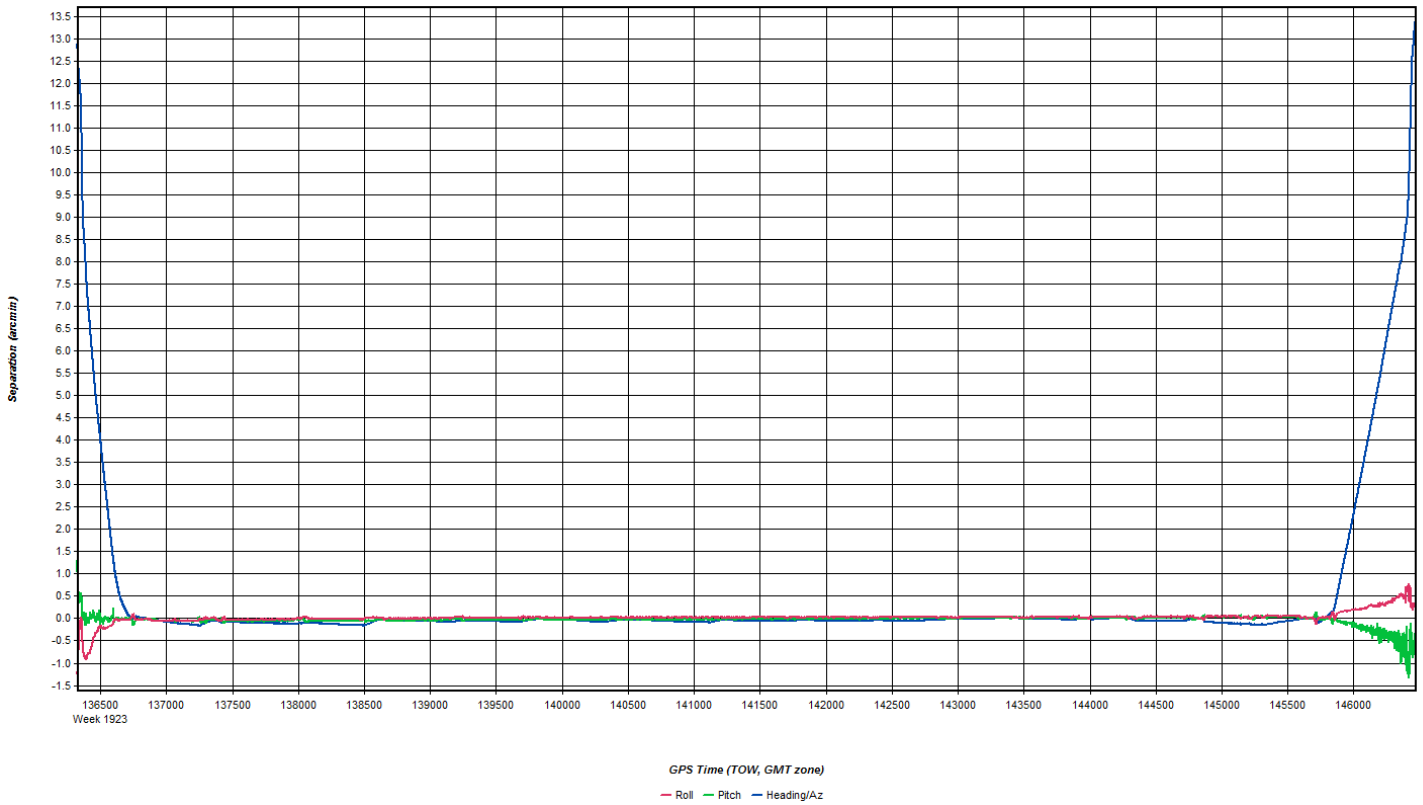
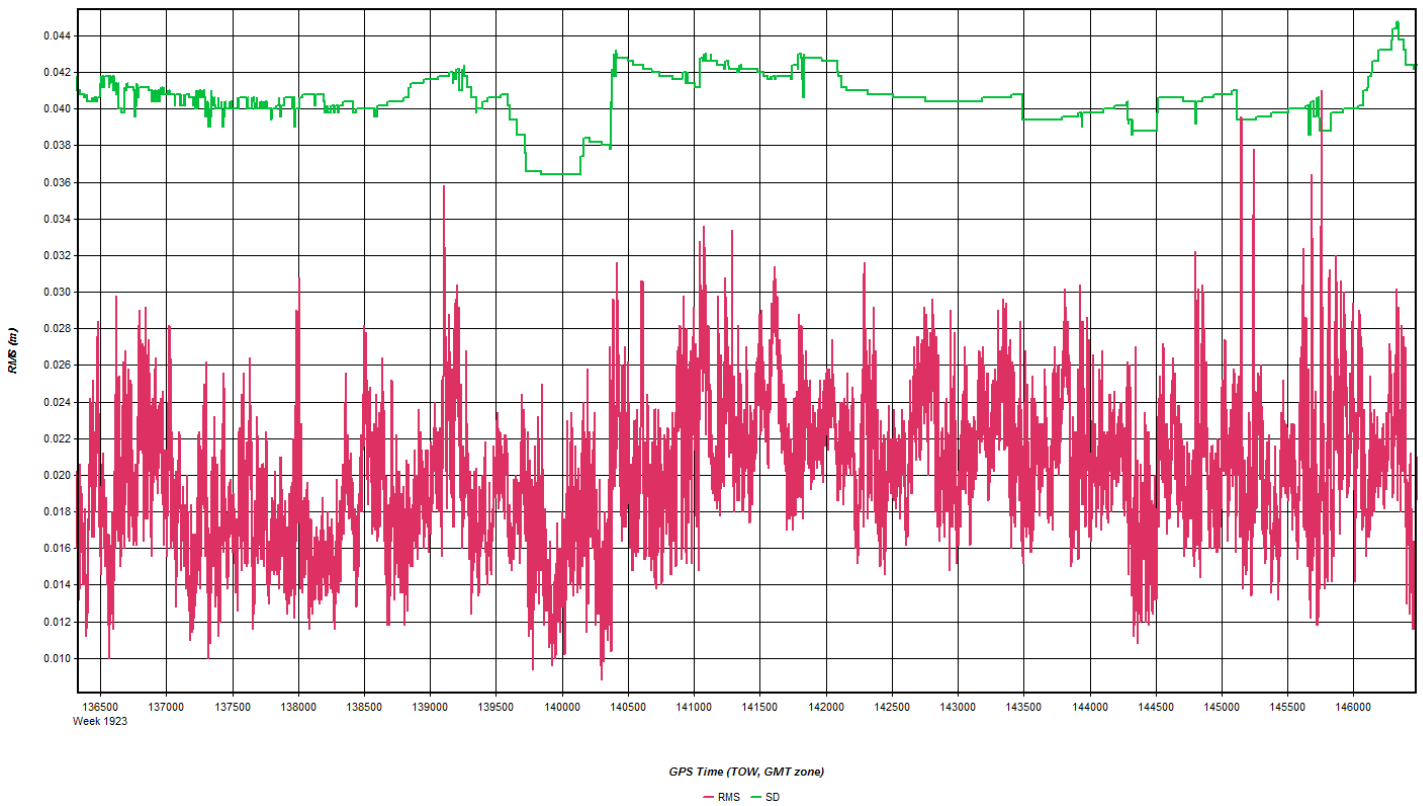

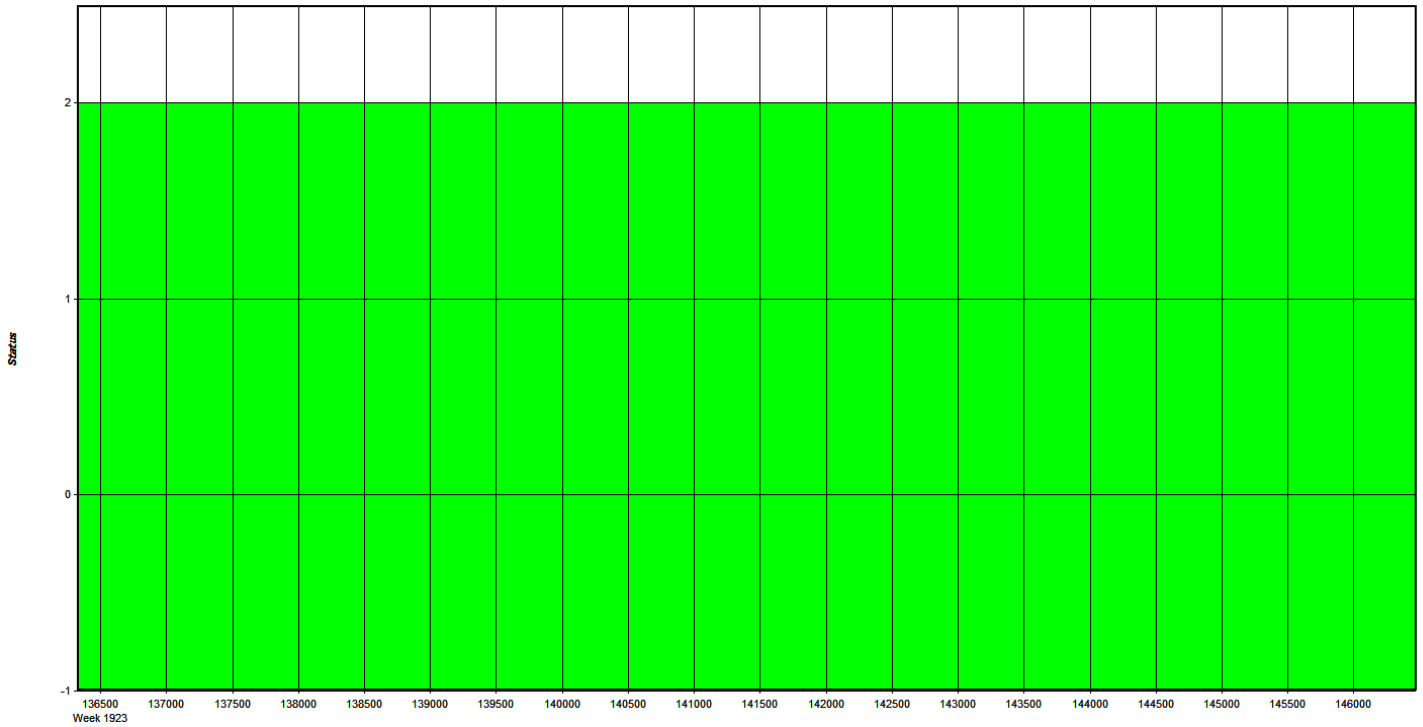

GPS Time (TOW, GMT zone)
 - Float - Forward Fixed - Reverse Fixed - Fixed (2 or more)

Coordinate/Antenna Settings

Master Remote

Base Station
 1: VTD7 Name: VTD7 Disabled
 File: E:\Proc\29178_CT_River\29178_ALS70_N22GE\20161114_131

Coordinates
 Latitude: North 44 23 52.31066 Compute from PPP
 Longitude: West 72 01 32.39267 Enter Grid Values
 Ellipsoidal height: 166.528 m Enter MSL Height
 Datum: WGS84 Datum Options
 Select From Favorites Add To Favorites Use Average Position

Antenna Height
 From station file: TRM55971.00, NONE View STA File
 Antenna profile: TRM55971.00 Info
 Measured height: 0.000 m
 ARP to L1 offset: 0.067 m
 Applied height: 0.067 m
 Measured to:
 ARP
 L1 Phase Centre
 Compute From Slant

OK Cancel

Coordinate/Antenna Settings ? X

Master Remote

Base Station
2: VTIP Name: VTIP Disabled
File: E:\Proc\29178_CT_River\29178_ALS70_N22GE\20161114_131

Coordinates
Latitude: North 44 49 12.18043 Compute from PPP
Longitude: West 71 53 25.83872 Enter Grid Values
Ellipsoidal height: 341.732 m Enter MSL Height
Datum: WGS84 Datum Options
Select From Favorites Add To Favorites Use Average Position

Antenna Height
From station file: TRM55971.00, NONE View STA File
Antenna profile: TRM55971.00 Info
Measured height: 0.000 m
ARP to L1 offset: 0.067 m
Applied height: 0.067 m
Measured to
 ARP
 L1 Phase Centre
Compute From Slant

OK Cancel

Flight Log

Scanned by CamScanner

11-14-16 A 29178

Quantum Spatial
Airborne LIDAR Data Collection Log Sheet :: Quantum Spatial, Inc
(email log daily to flight_log_distribution_list@quantumspatial.com)

Date: 11-14-16 A
UIC: B C D E 141 of 2

Project: CT River VT
Flight Mgmt File: 2016114-131642

Aircraft: M22GE Begin Hobbs: 8966.2 End Hobbs: 8969.6 Total: 3.4 Pilot: TP Adtke Co-Pilot: Tech: JSW 17
Dep Apt: KLEB Dep Time (Lcl): 833 ZF: +5 Arr Apt: KLEB Arr Time (Local): 1206 ZF: +5 Tot Time Aloft: 3.5

CORS: Y/N Sta 1: VTDF 1354 Sta 2: Flyovers: Y/N IF Y, times: Stat1 Stat2
GPS Unit: Y/N Sta 1: 1637 Sta 2: Flyovers: Y/N IF Y, times: Stat1 Stat2

Gd Temp beg: °C End: °C OAT beg: +4 °C End: +5 °C Altimeter begin: 2996 end: 2990

Type	FOV	Scan Freq	Alt AGL	MplA Y/N	Pulse Rate	Avg Terr Ht	Max Gdspd	Power	Avg Pt Spacing	PPSM	Mag Cal	End Cal	Tot Cal	Storage Name
LIDAR	70	40	53 Hz	Y/N	260 kHz	100%	100%	100%	100%	100%	99	73	26	17

Line #	Hgt	Start (UTC)	End (UTC)	Gd Spd	POOP/s	GPS Altitude	Crab	Turb
		1333	1354					
3088	22	1405	1406	160	1.3/17	7870	0	0
3089	202	1410	1413	141	1.3/17	7829	0	0
3090	22	1421	1428	157	1.2/17	7876	0	0
3091	202	1431	1437	144	1.1/18	7869	0	0
3092	22	1441	1447	152	1.1/17	8014	0	0
3093	202	1451	1457	155	1.0/18	8141	0	0
3094	22	1505	1511	167	1.2/16	8157	0	0
3095	202	1515	1520	157	1.2/16	8140	0	0
3096	22	1525	1530	161	1.2/16	8114	0	0
3097	202	1534	1539	155	1.2/16	8073	0	0
3098	22	1544	1549	162	1.2/15	8053	0	0
3099	202	1553	1557	152	1.2/15	8200	0	0
3100	22	1600	1604	166	1.0/19	8163	0	0
3101	202	1607	1611	153	1.0/18	8150	0	0
3102	22	1615	1618	161	1.0/19	7926	0	0
xTire	287/622	1626	1626	147	1.0/17	7960	0	0
		1626	1700					

LEB → VTDF - (Fig 8's 1402 Z)

Hobbs time = 3.4
Outline time = 2.3
mob time = 1.1

0 unplanned
Site → KLEB (Fig 8's 1626) (VTDF 1637)

FLIGHT LINE NOTES - visibility, clouds, smoke, partic, etc

Total Proj Lines: Lines Flow: Lines Remain: Online Time: 2.3 Mob Time: 1.1 Notes:

Nov 14, 2016-A (N73TM, SN7178)

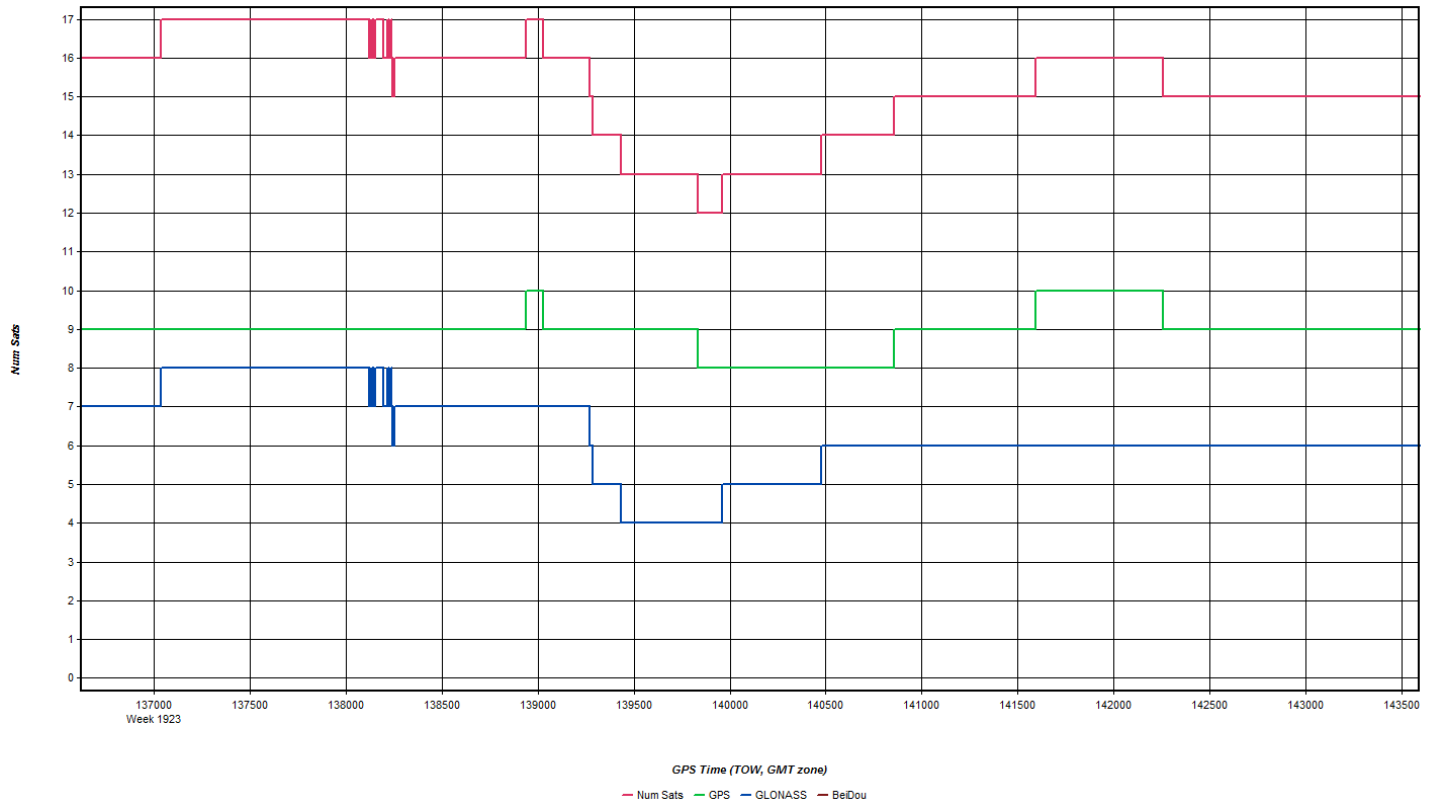
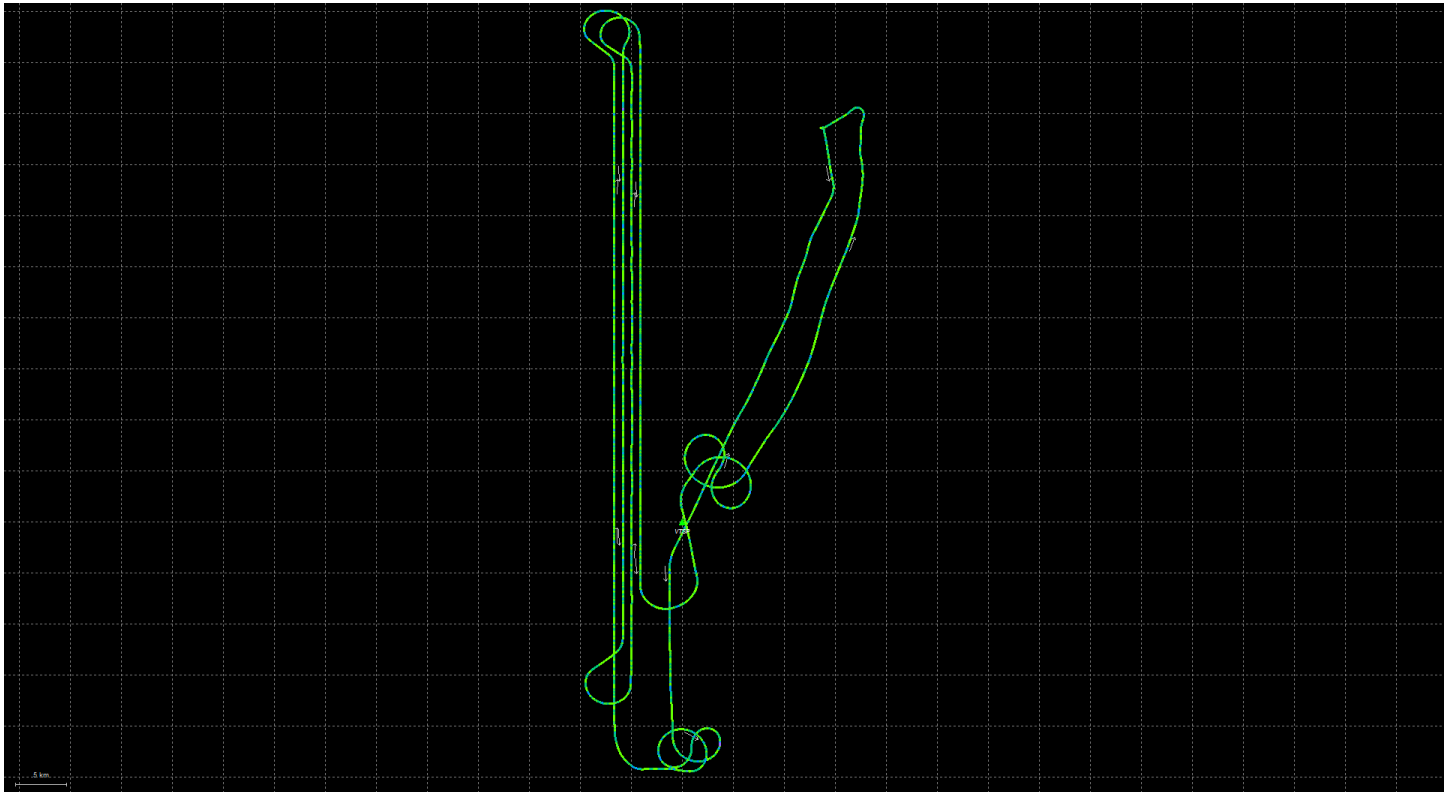

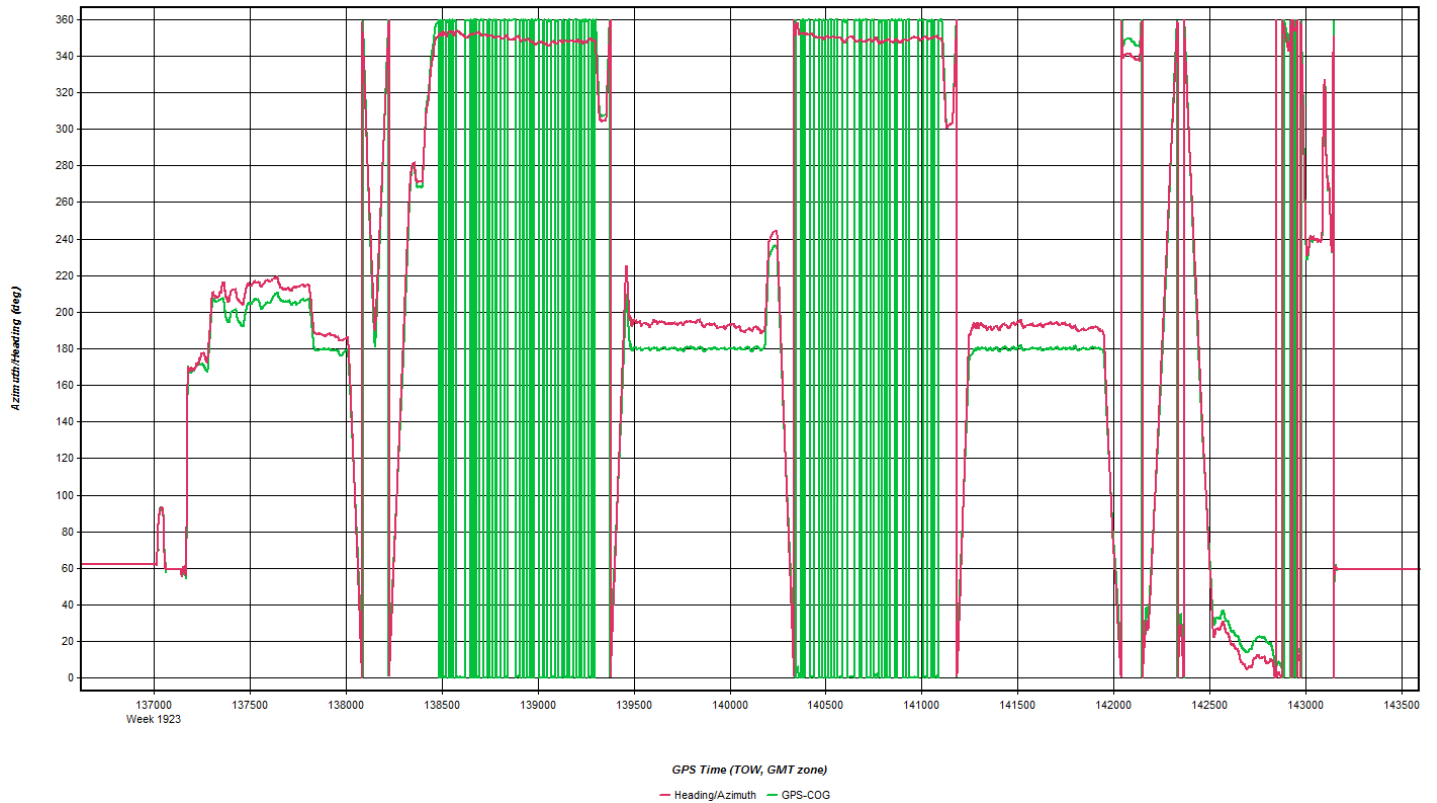
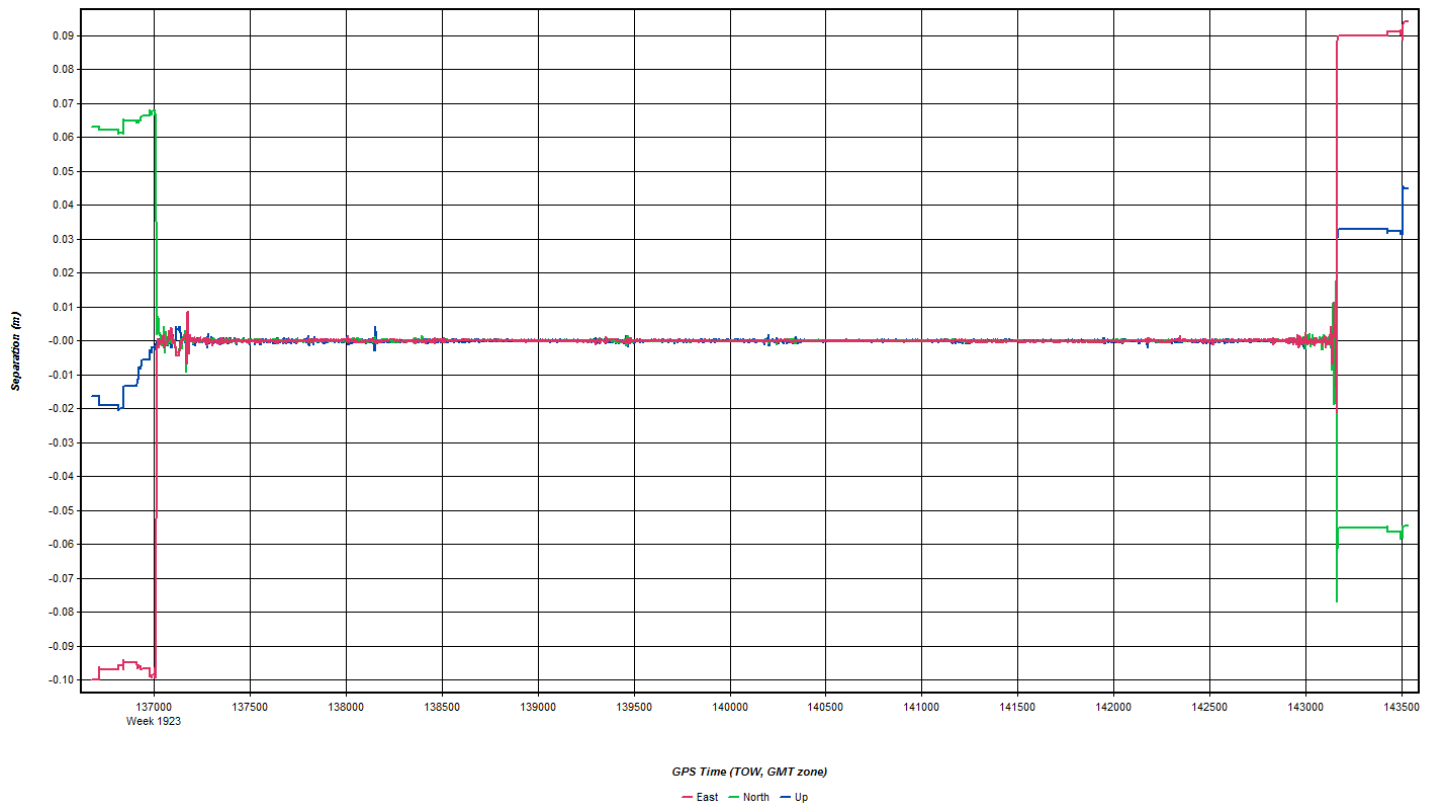

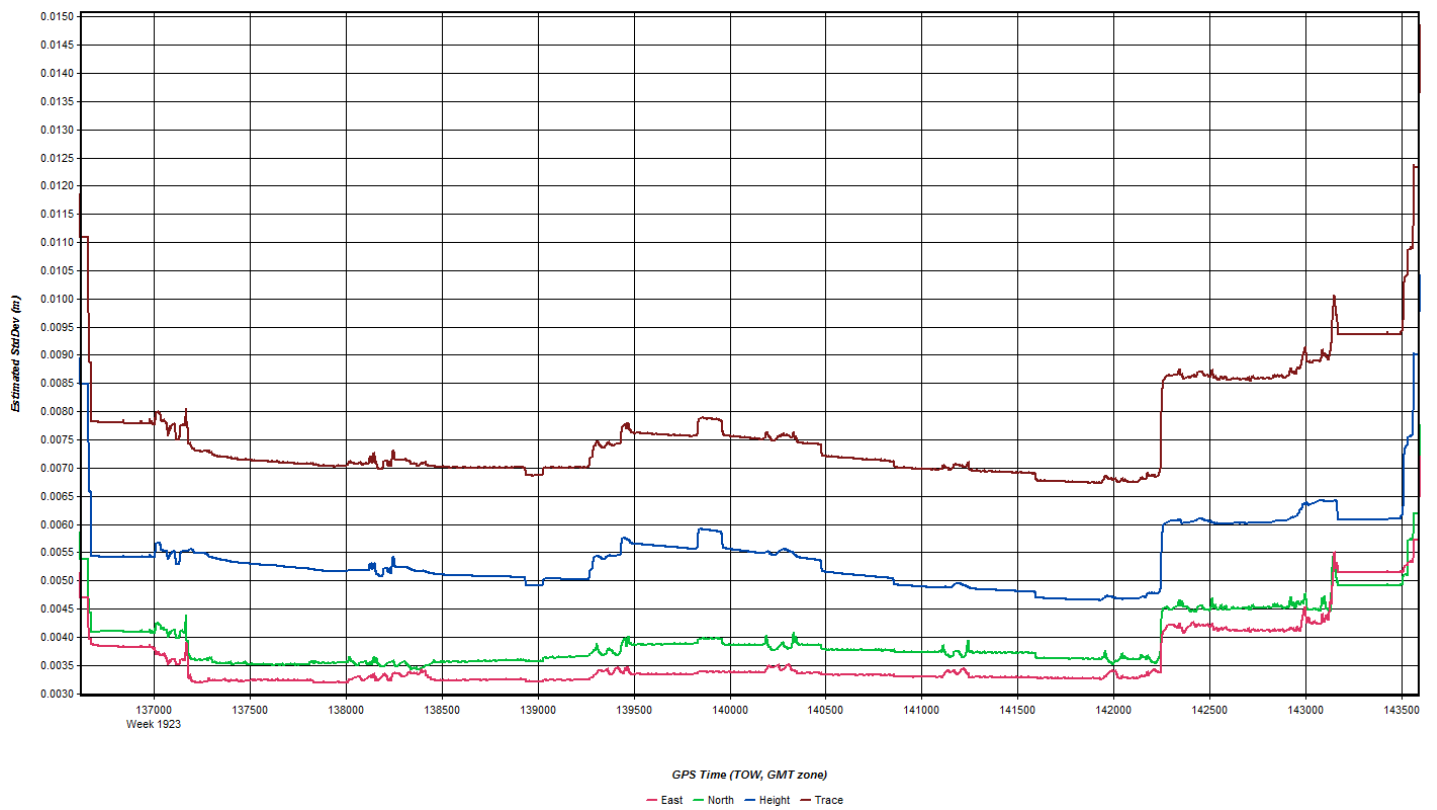
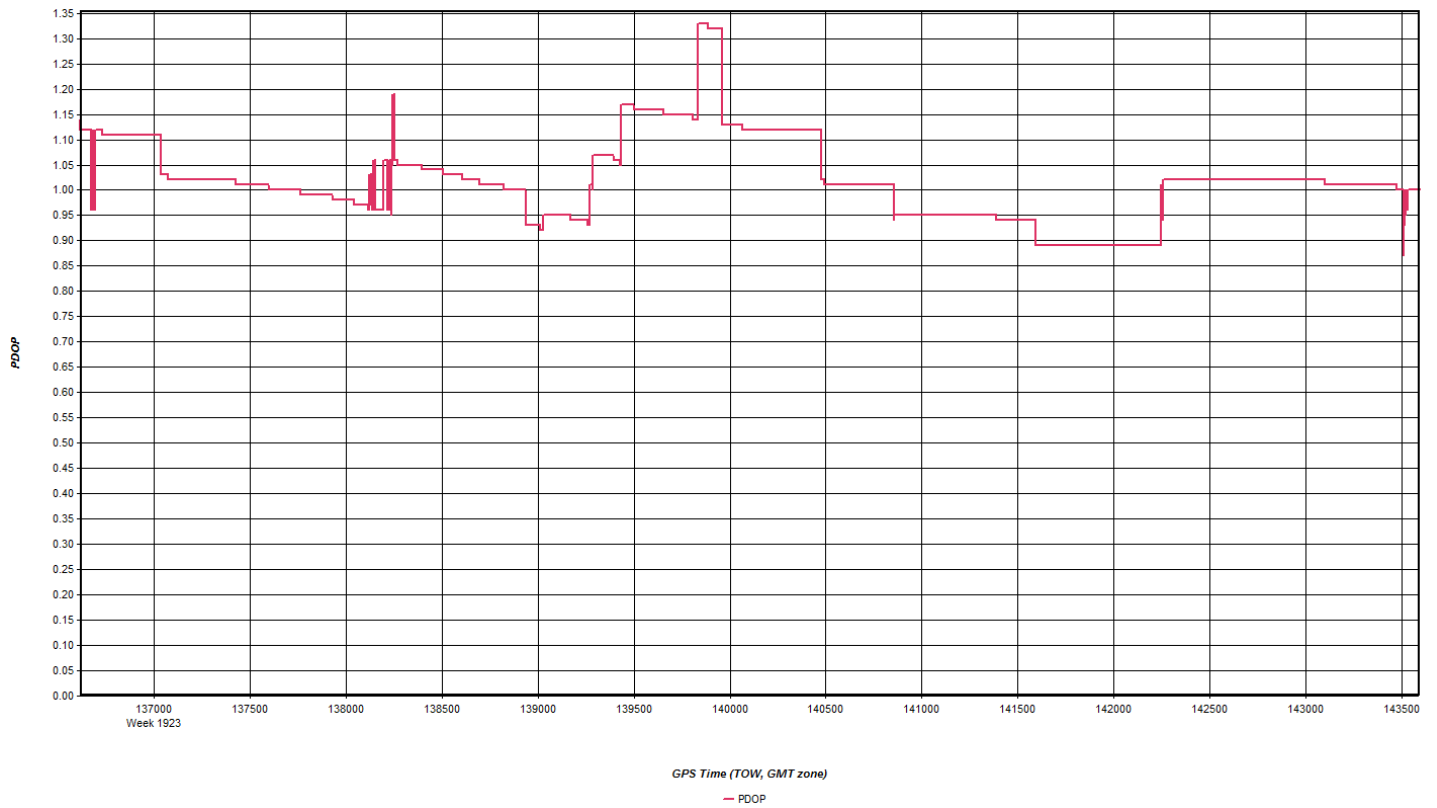

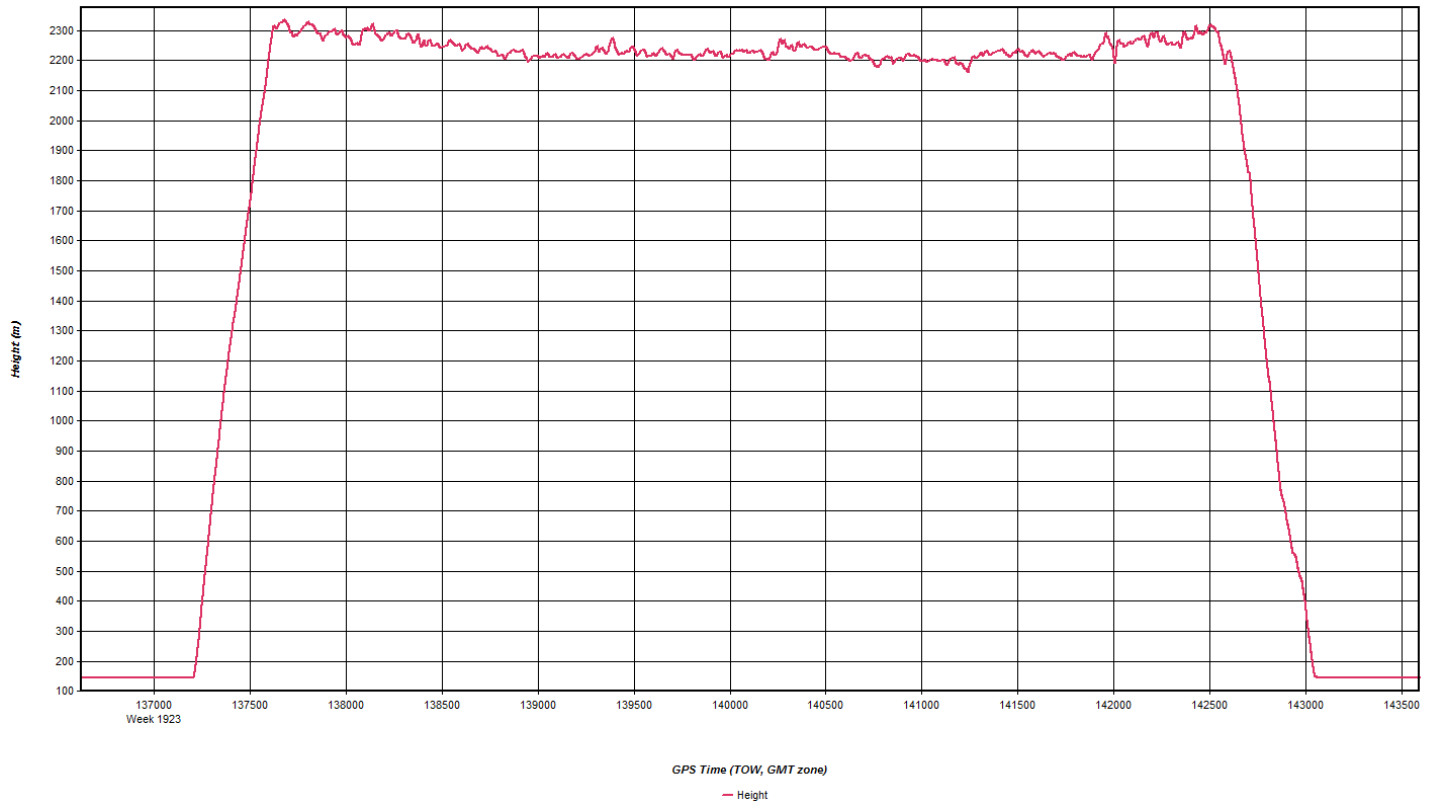

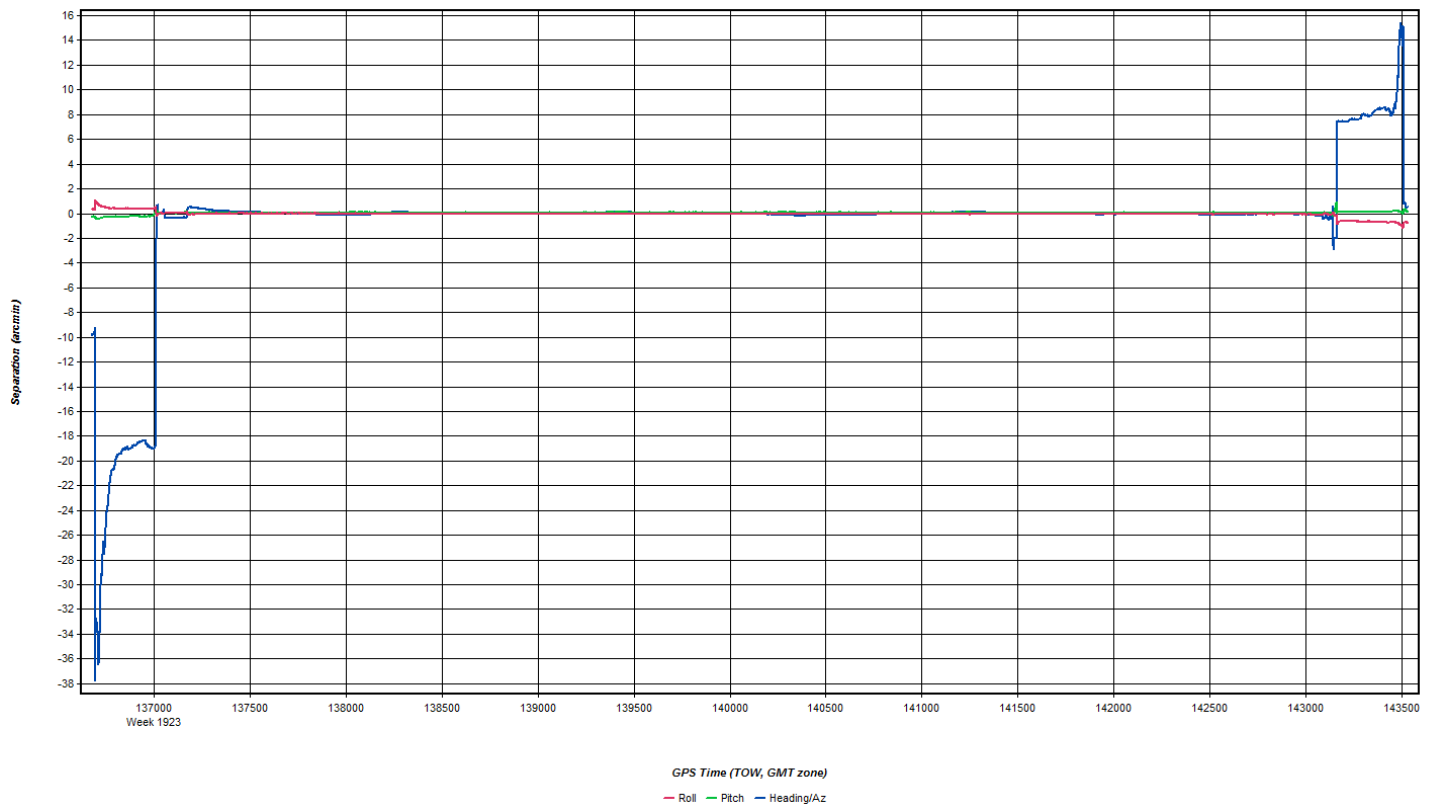
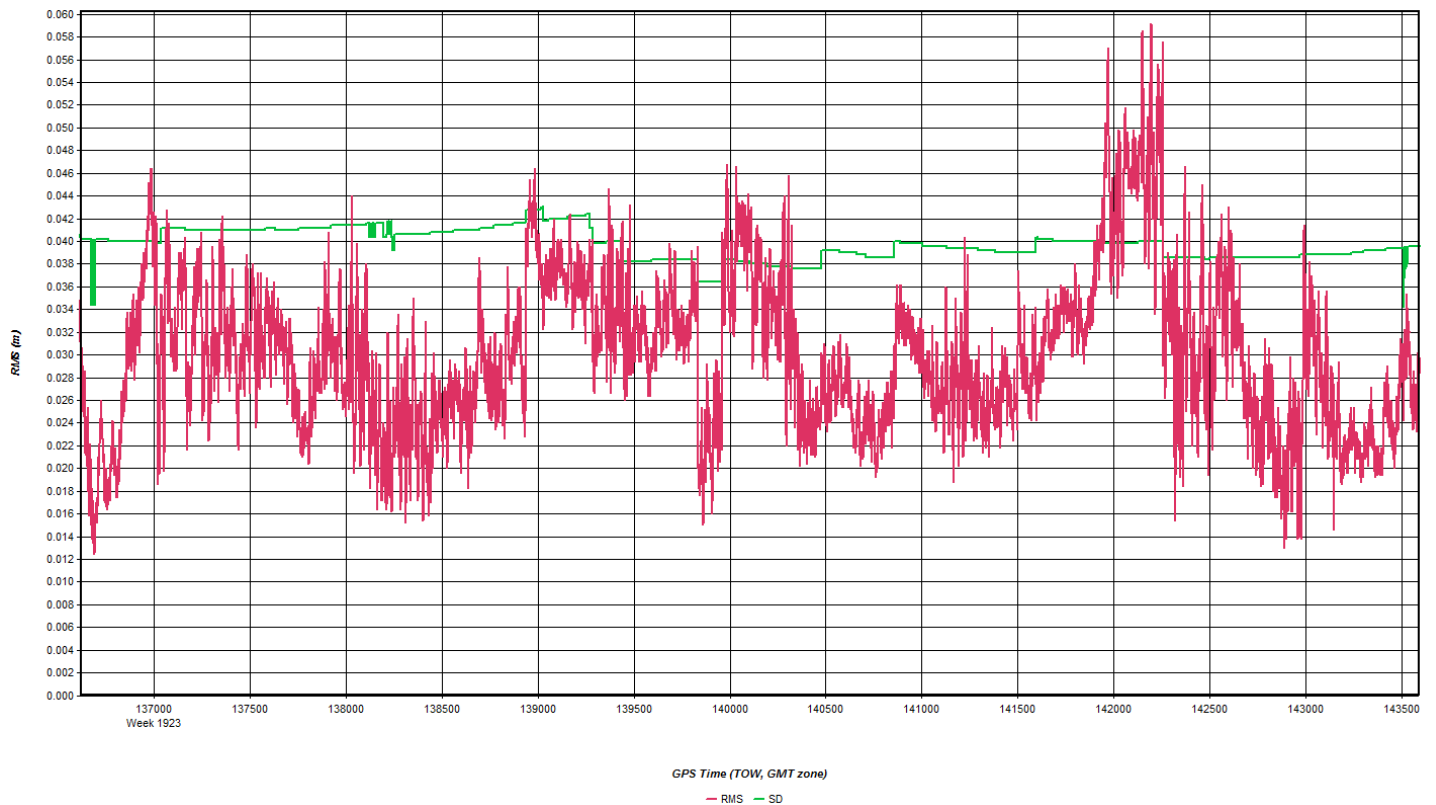

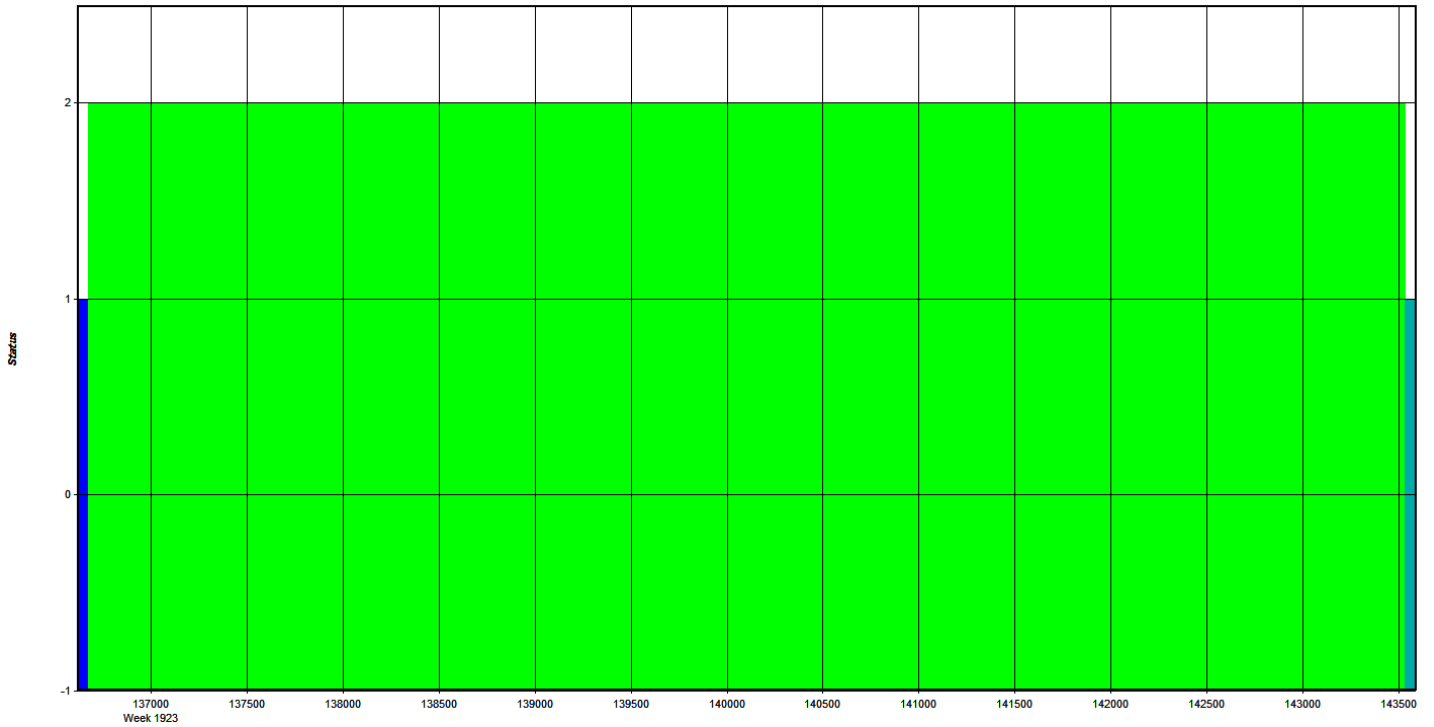

GPS Time (TOW, GMT zone)
 - Float - Forward Fixed - Reverse Fixed - Fixed (2 or more)

Coordinate/Antenna Settings

Master Remote

Base Station
 1: VTSP Name: VTSP Disabled
 File: E:\Proc\29178_VT_CT_River_Basin\From_M_Aust_11-15-16\201

Coordinates
 Latitude: North 43 16 53.24114 Compute from PPP
 Longitude: West 72 28 39.23841 Enter Grid Values
 Ellipsoidal height: 156.441 m Enter MSL Height
 Datum: WGS84 Datum Options
 Select From Favorites Add To Favorites Use Average Position

Antenna Height
 From station file: TRM55971.00, NONE View STA File
 Antenna profile: TRM55971.00 Info
 Measured height: 0.000 m
 ARP to L1 offset: 0.067 m
 Applied height: 0.067 m
 Measured to:
 ARP
 L1 Phase Centre
 Compute From Slant

OK Cancel

Flight Log

Project: U.S.S. CT RIVER LIDAR **Proj #:** 29178 **Flight Mgmt File:** 2016114-135934

Aircraft: 737M **Begin Hobbs:** 6499.3 **End Hobbs:** 6510.0 **Total:** 17 **Pilot:** J. BUEHNER **Co-Pilot:** Tech: M. Mast

Dep Apt: LEB **Dep Time (Local):** 9:05 (Z): 14:08 **Arr Apt:** LEB **Arr Time (Local):** 10:17 (Z): 15:50 **Tot Time Aloft:** 1:75

CORS: N S E W **Sta 1:** VTS. # **Sta 2:** **Flyovers:** N S E W **Stations:** (4:16, 15:58 Sta2)

GPS Unit: Y / N **Sta 1:** **Sta 2:** **Flyovers:** Y / N **Stations:** Sta1) Sta2)

Date: 11-14-16 **Pg. 1 of 1**

Utr: A B C D E

Line #	Type	Hdg	Start (UTC)	End (UTC)	Gd Spd	POOF* srs	GPS Altitude	Crab	Turb [0...4]	Alt AMSL	Alt AGL	MplA <input checked="" type="checkbox"/> N	Pulse In Air	Pulse Rate	Avg Terr Ht	Max Gdspd	Power	Avg Ft Spacing	PPSM	Altimeter begin:	end:	Mag CB	End CB	Tot CB	Storage Name/e	
																										°C
LIDAR																										
1032	N		1428	1441	151	1.1/18	7.4			7.5										2996	2995		282			4
1033	S		1444	1456	153	1.0/18	7.3																			
1034	N		1459	1511	156	1.1/17	7.4																			
1035	S		1514	1525	143	1.2/16	7.3																			

FLIGHT LINE NOTES - visibility, clouds, smoke, partial, etc

Total Proj Lines:	Lines Flown:	Lines Remain:	Online Time: /	Mobile Time: 75	Notes:
--------------------------	---------------------	----------------------	-----------------------	------------------------	---------------

Nov 14, 2016-B (N22GE, SN7161)

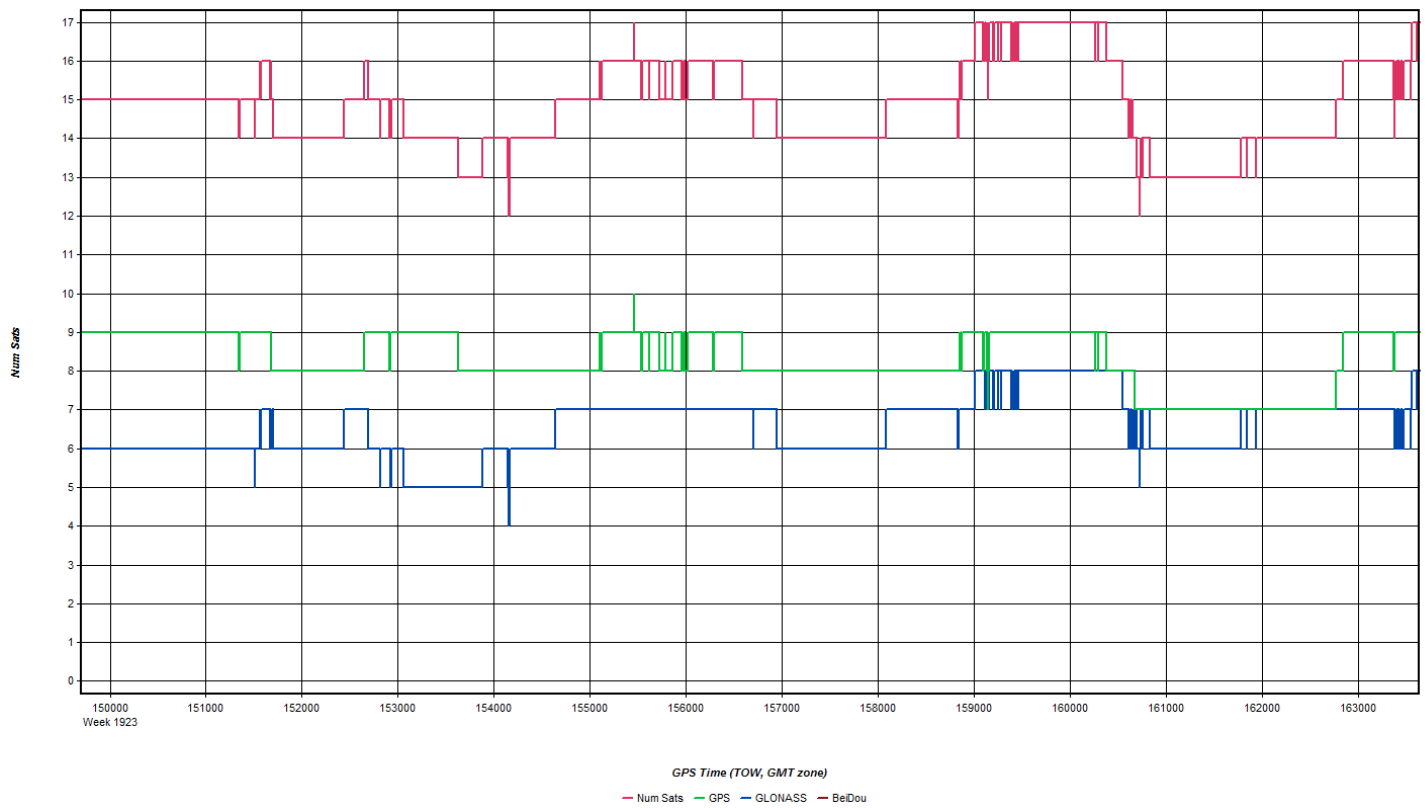
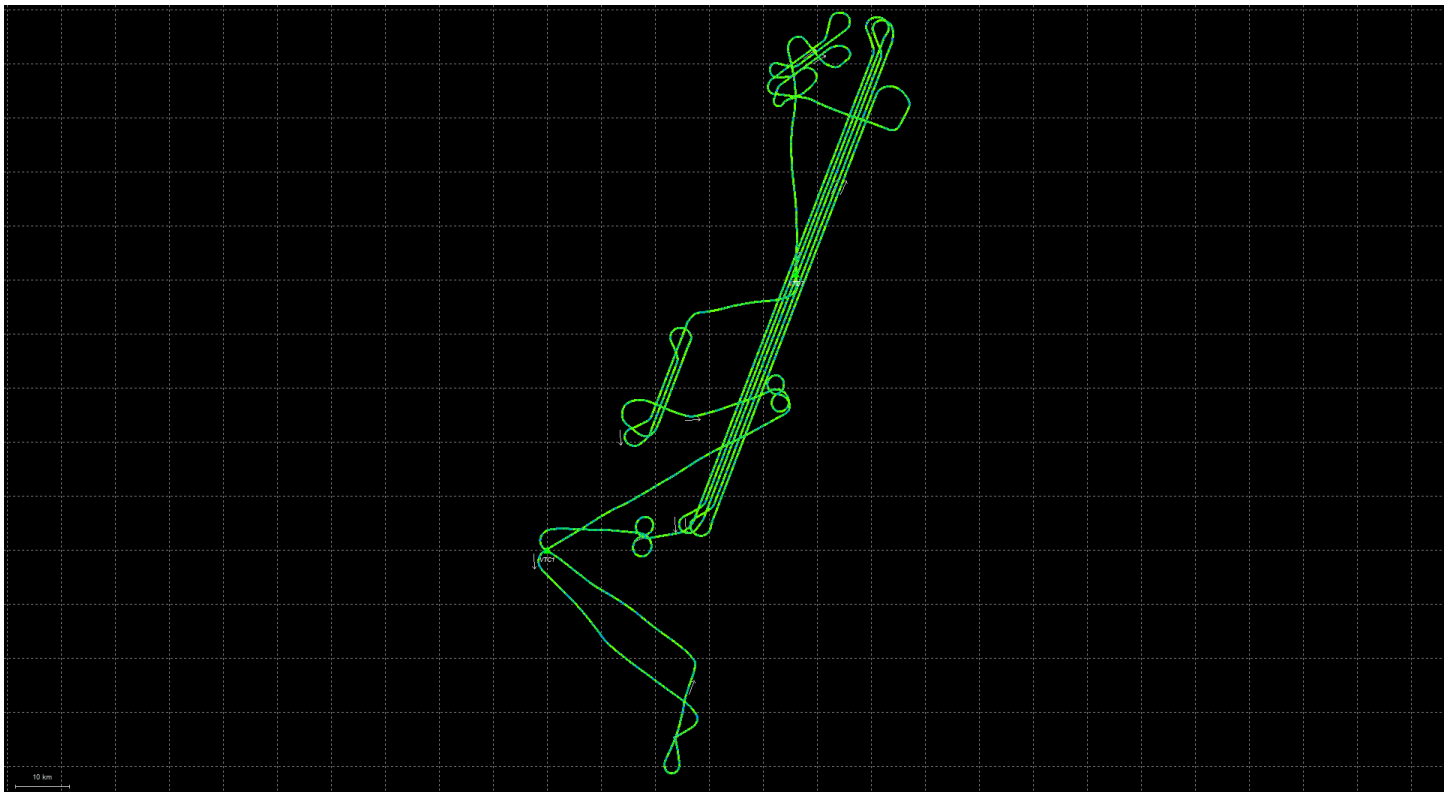

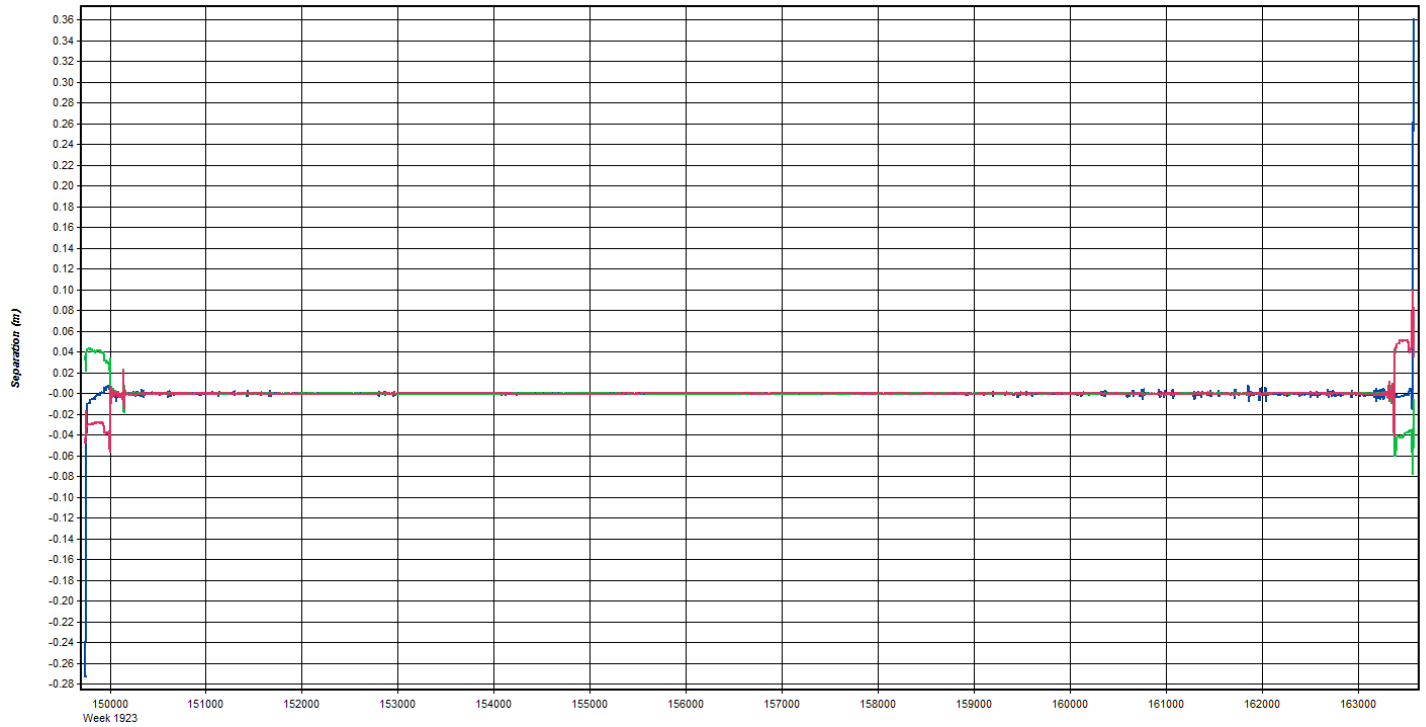

GPS Time (TOW, GMT zone)

— East — North — Up

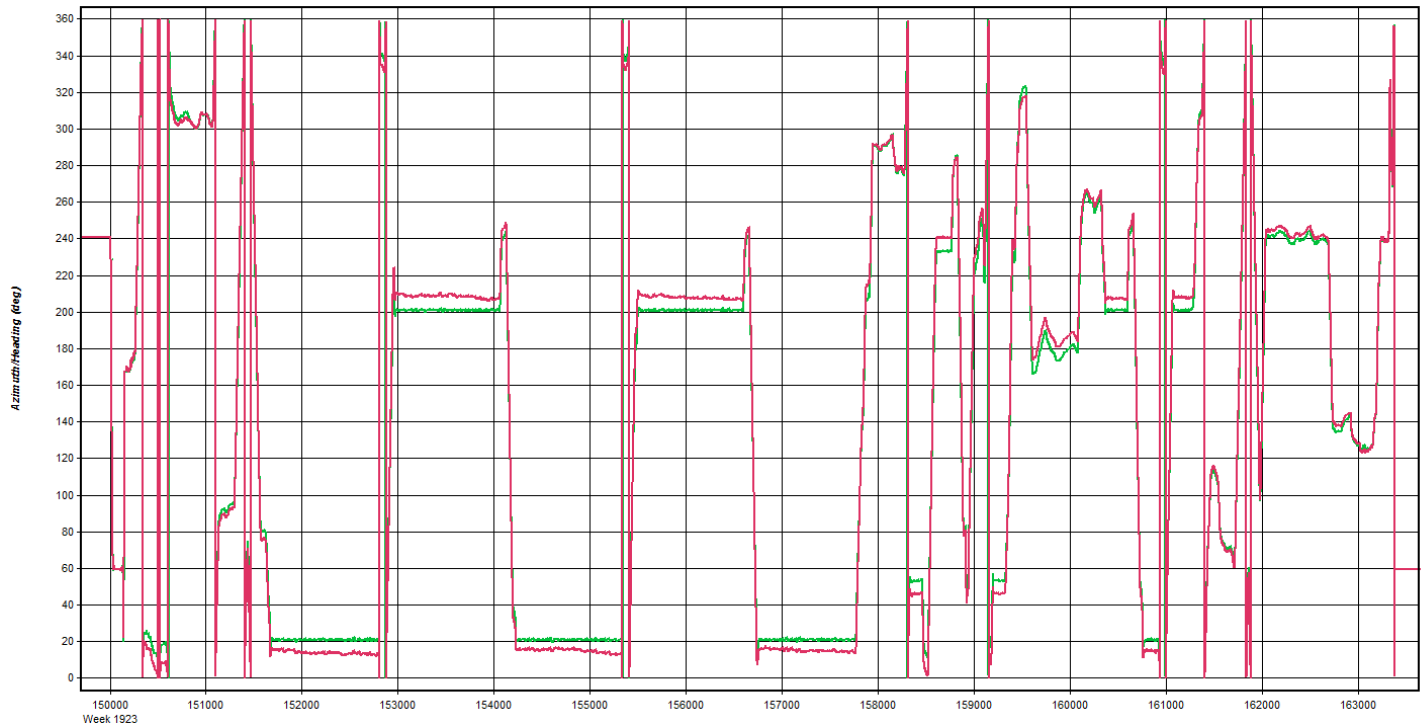

GPS Time (TOW, GMT zone)

— Heading/Azimuth — GPS-COG

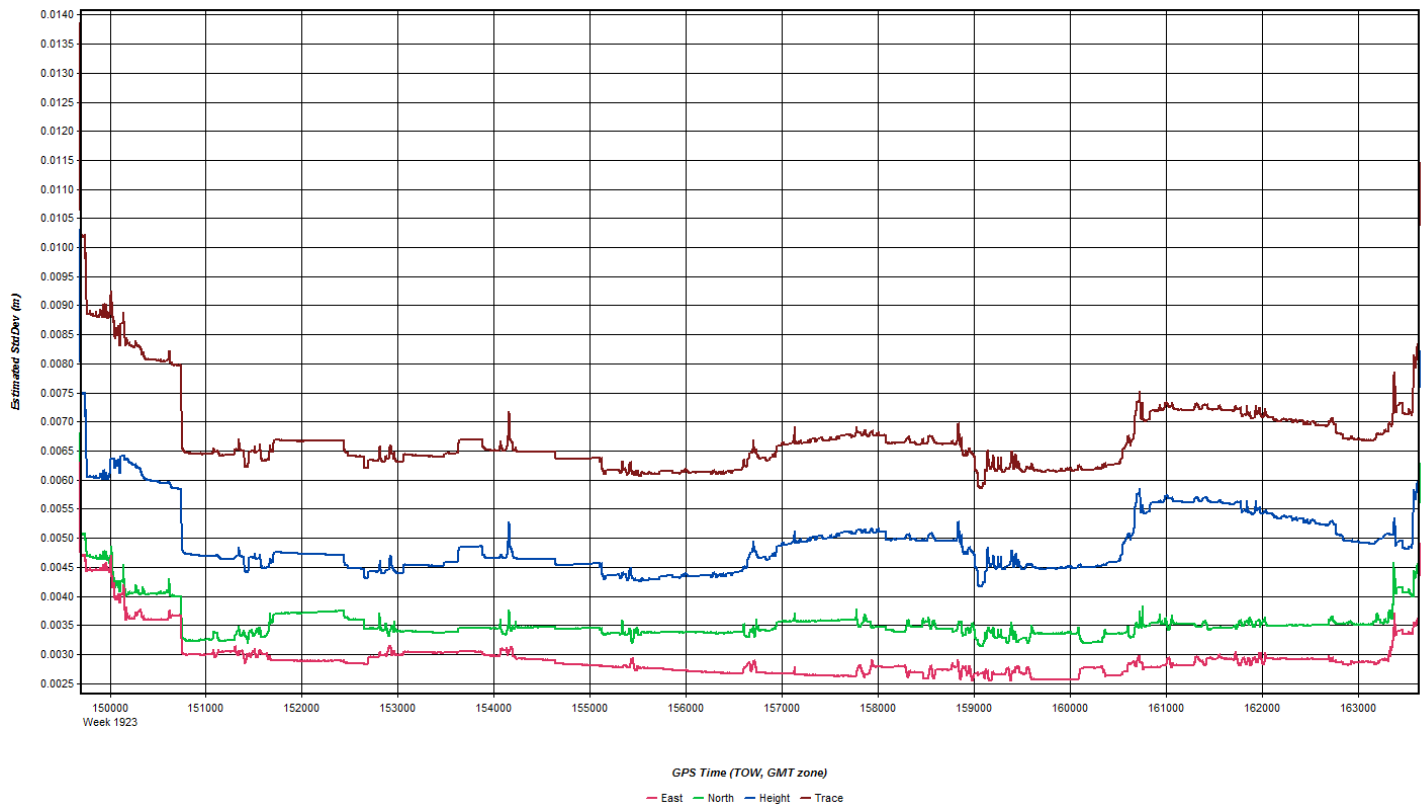
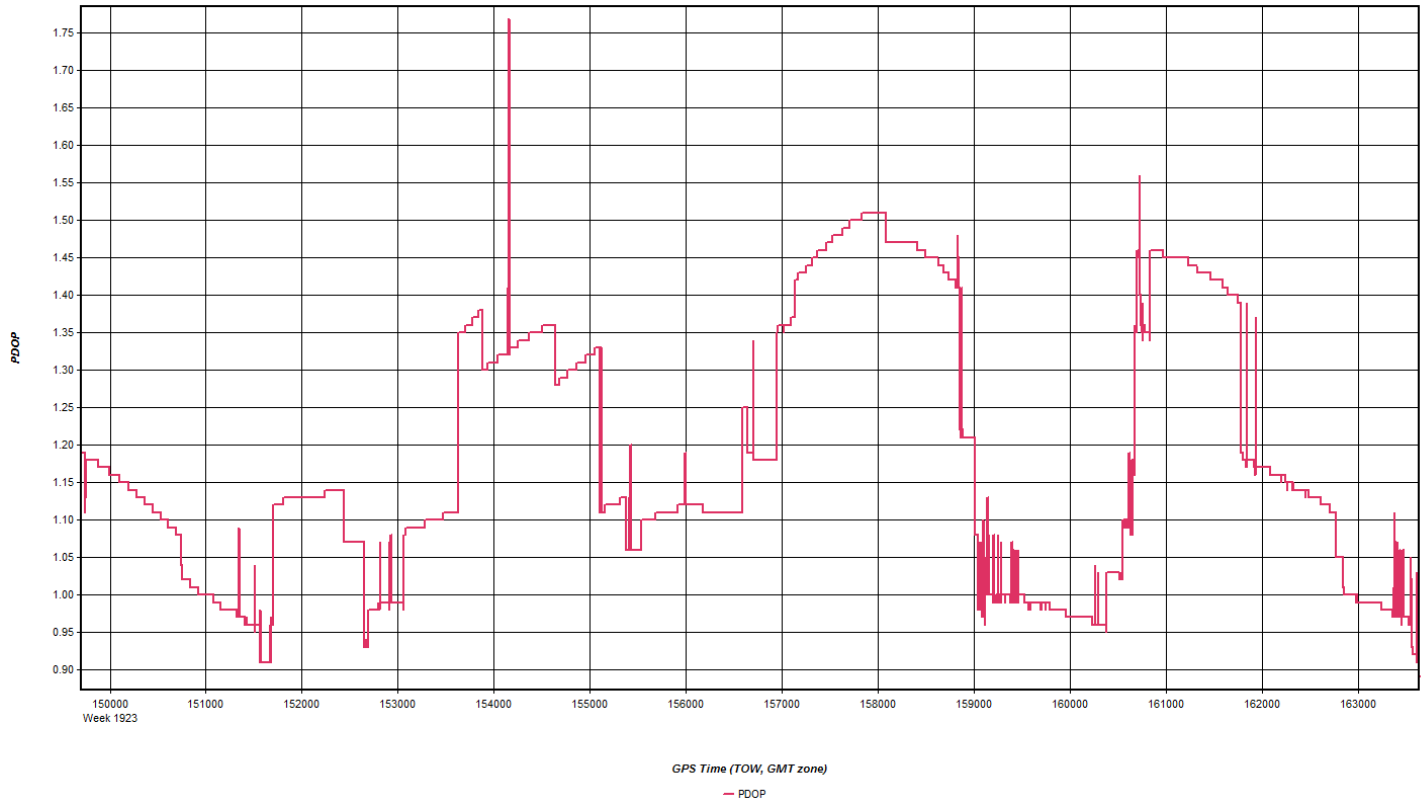

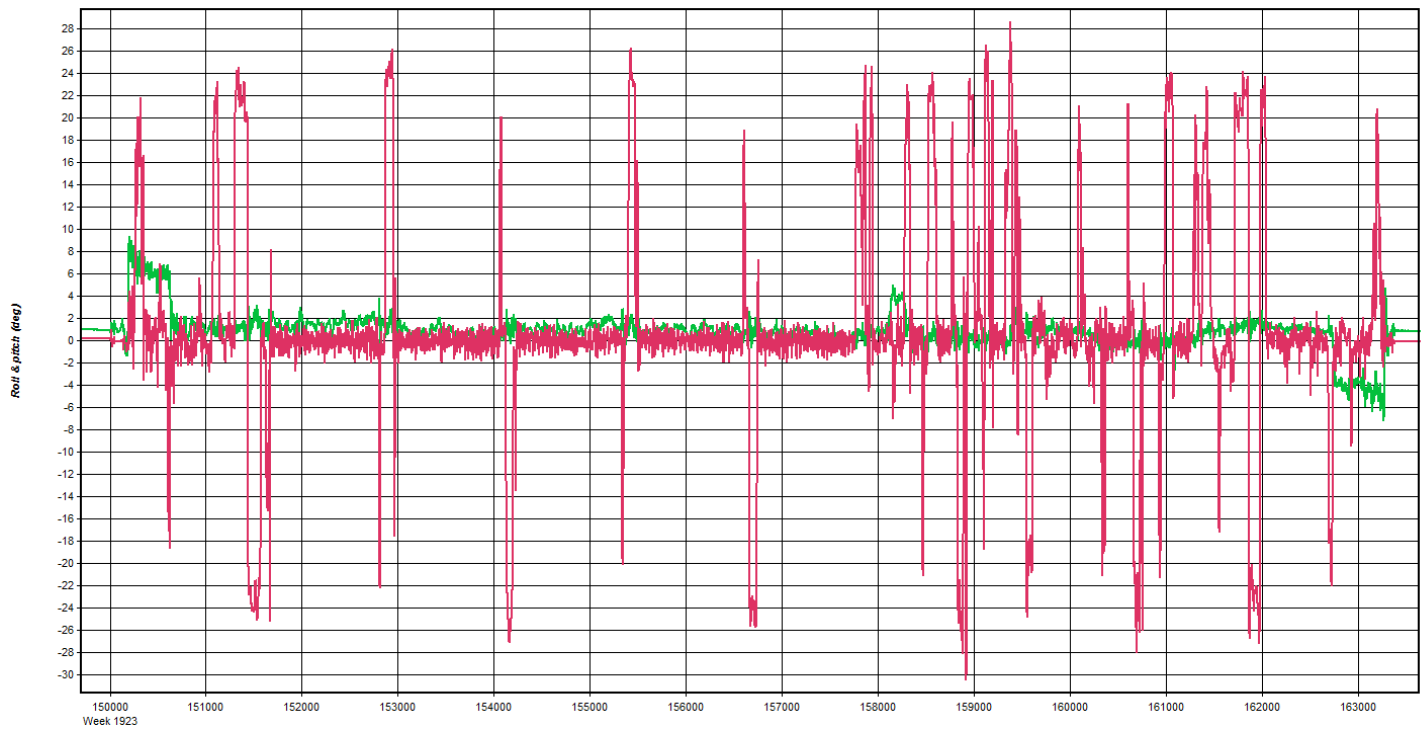

GPS Time (TOW, GMT zone)

— Roll — Pitch

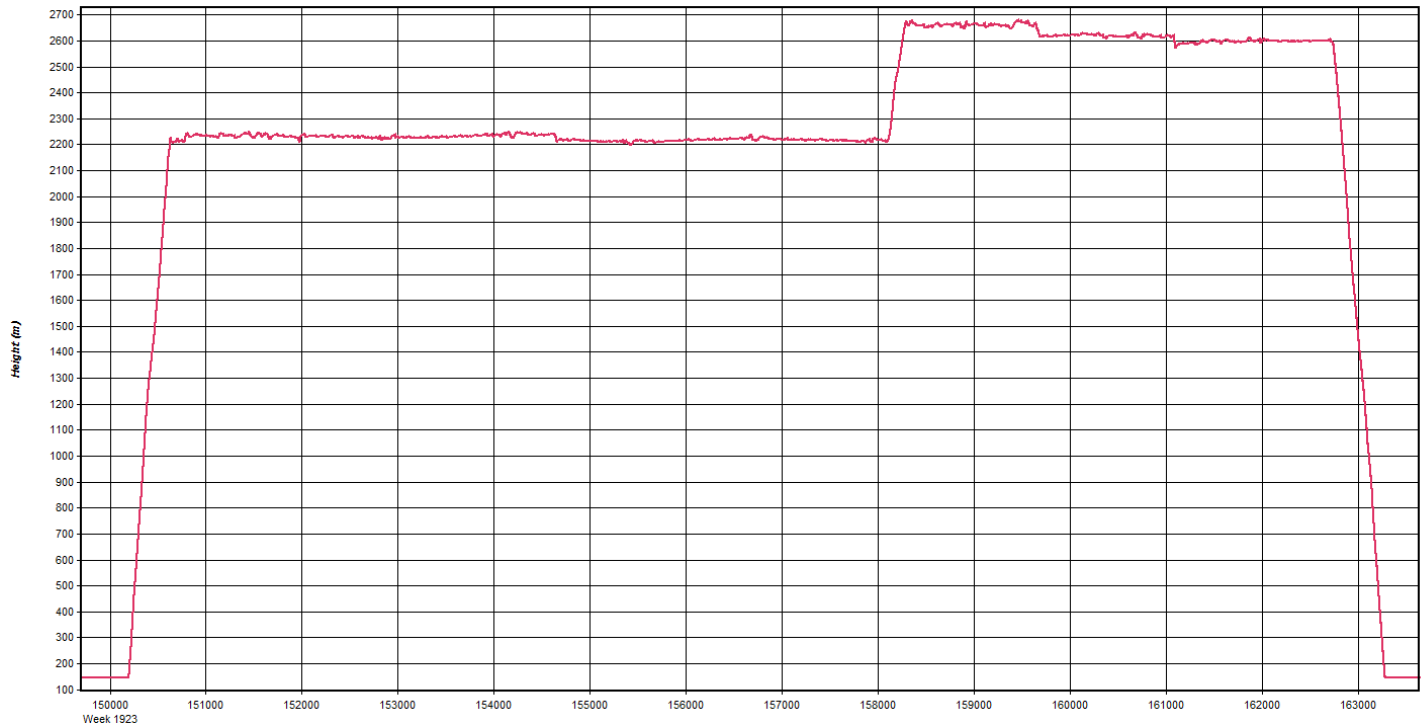

GPS Time (TOW, GMT zone)

— Height

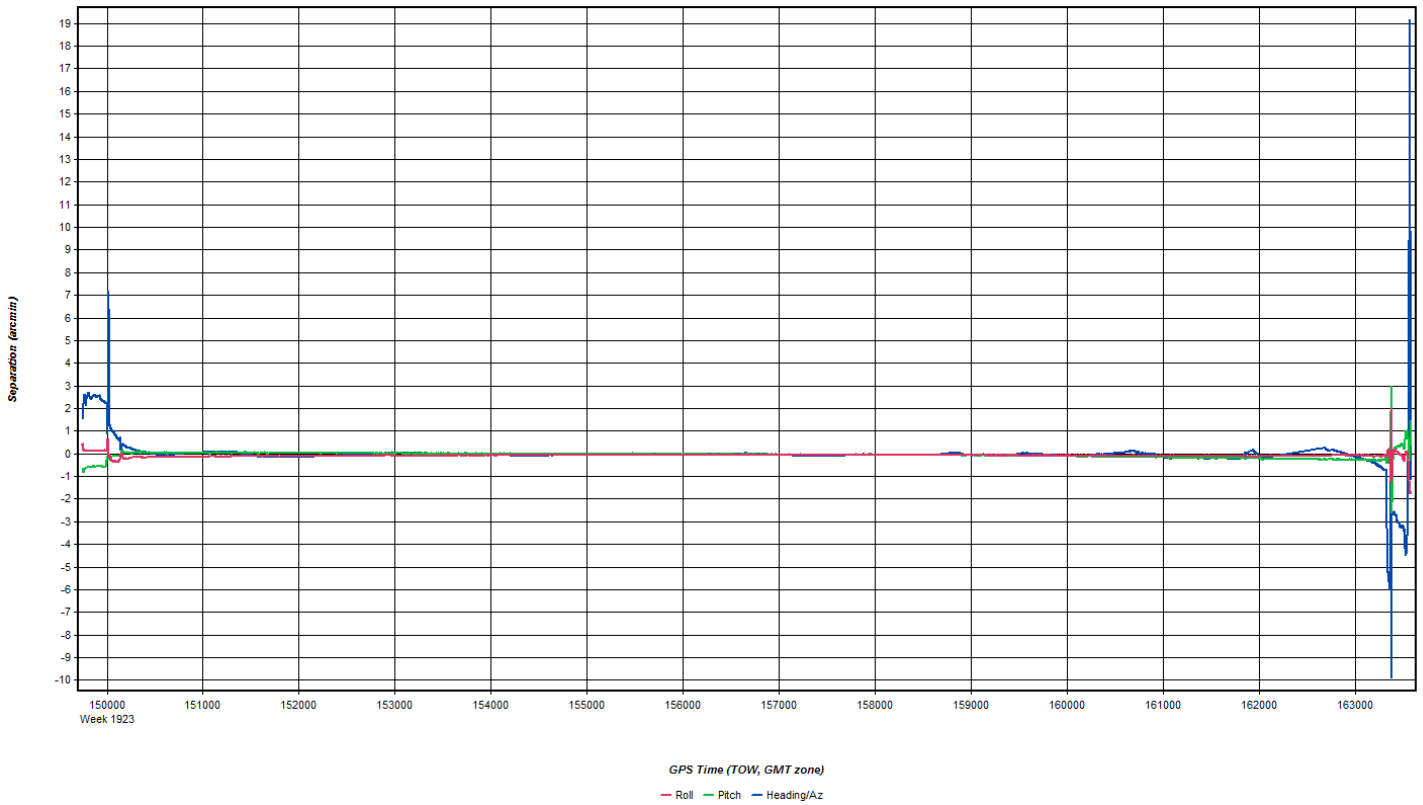
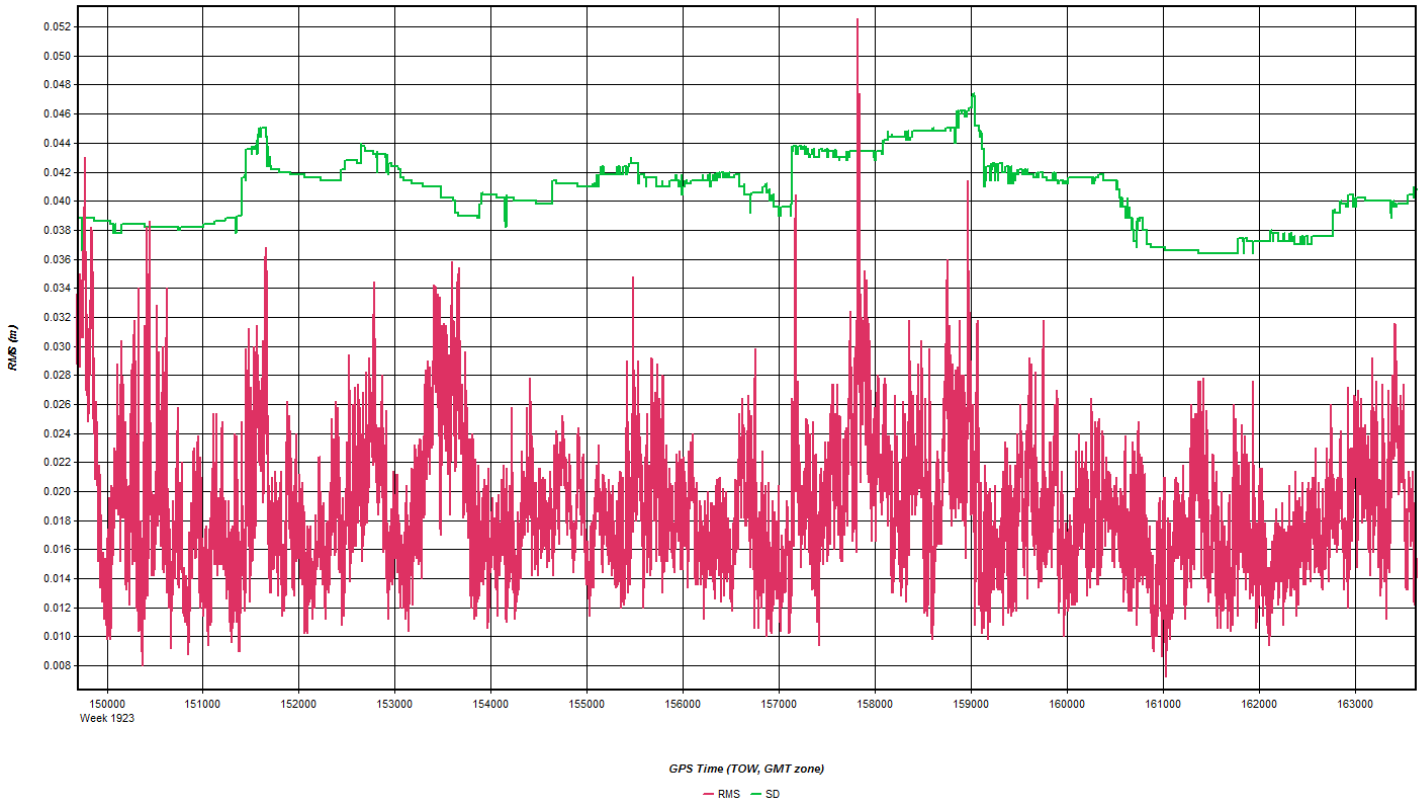

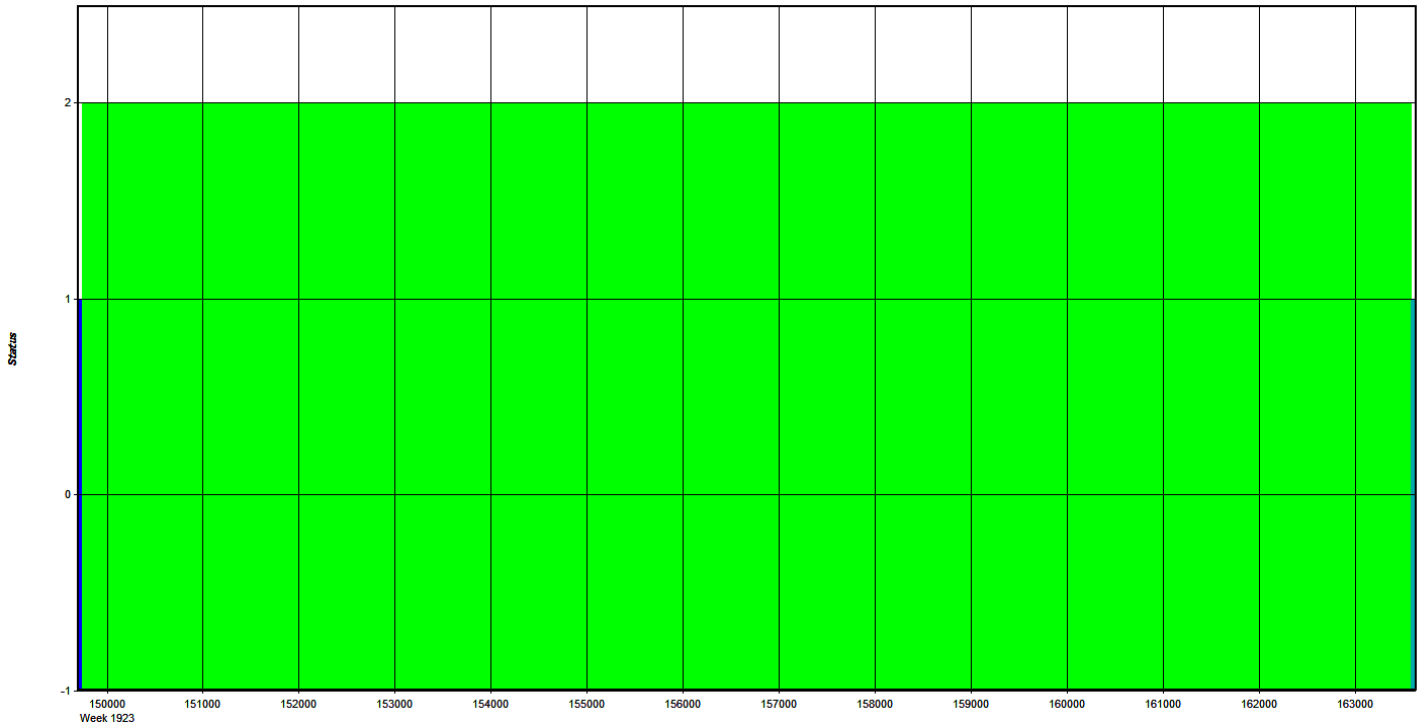

GPS Time (TOW, GMT zone)
 - Float - Forward Fixed - Reverse Fixed - Fixed (2 or more)

Coordinate/Antenna Settings

Master Remote

Base Station
 1: VTC1 Name: VTC1 Disabled
 File: E:\Proc\29178_CT_River\29178_ALS70_N22GE\20161114_173

Coordinates
 Latitude: North 43 56 21.21809 Compute from PPP
 Longitude: West 72 36 12.56537 Enter Grid Values
 Ellipsoidal height: 405.144 m Enter MSL Height
 Datum: WGS84 Datum Options
 Select From Favorites Add To Favorites Use Average Position

Antenna Height
 From station file: TRM55971.00, NONE View STA File
 Antenna profile: TRM55971.00 Info
 Measured height: 0.000 m
 ARP to L1 offset: 0.067 m
 Applied height: 0.067 m
 Measured to
 ARP
 L1 Phase Centre
 Compute From Slant

OK Cancel

Coordinate/Antenna Settings

Master Remote

Base Station
2: VTD7 Name: VTD7 Disabled
File: E:\Proc\29178_CT_River\29178_ALS70_N22GE\20161114_173

Coordinates
Latitude: North 44 23 52.31066 Compute from PPP
Longitude: West 72 01 32.39267 Enter Grid Values
Ellipsoidal height: 166.528 m Enter MSL Height
Datum: WGS84 Datum Options
Select From Favorites Add To Favorites Use Average Position

Antenna Height
From station file: TRM55971.00, NONE View STA File
Antenna profile: TRM55971.00 Info
Measured height: 0.000 m
ARP to L1 offset: 0.067 m
Applied height: 0.067 m
Measured to:
 ARP
 L1 Phase Centre
Compute From Slant

OK Cancel

Flight Log

Date: 11-14-16 B
UFT: A B C D E Pg 2 of 2

Quantum Spatial
Airborne LIDAR Data Collection Log Sheet :: Quantum Spatial, Inc
(email: log.daily.to.flight_log_distribution_list@quantumspatial.com)

Project: CT River VT Proj #: 29178 Flight Mgmt File: 20161114-173026 Tech: SWAN

Aircraft: NZ2GE Begin Hobbs: 8969.6 End Hobbs: 89733 Total: 3.7 Pilot: TRadtke Co-Pilot: _____ Tot Time Aloft: 3.8

Dep Apt: KLEB Dep Time (Local): 1742Z Arr Apt: KLEB Arr Time (Local): 1721Z Flyovers: 0/1 N If Y, times: Sta1) Sta2) Storage Name: 017

CORS: (Y) N Sta 1: ~~VTD7~~ Sta 2: VTD7-1817 Flyovers: 0/1 N If Y, times: Sta1) Sta2) Max Gdspd Avg Pt Spacing Power PFSM

GPS Unit: Y/N Sta 1: VTD1-1757 Sta 2: VTD7-1817 Flyovers: 0/1 N If Y, times: Sta1) Sta2) Altimeter begin: 2992 end: 2992

Gd Temp beg: °C End: °C OAT beg: +8 °C End: +3 °C Pulse Rate Power 100

Line #	Hdg	Start (UTC)	End (UTC)	Gd Spd	POOP/Sec	GPS Altitude		Crs	Turb (0..3)	FLIGHT LINE NOTES - visibility, clouds, smoke, partial, etc			
						Alt AGL	Alt ANSL			Pulses In Air	Alt	Avg Terr Ht	Max Gdspd
		1742	1906							LEB → VTD1 (1757) - fig 8's (1801-1806)			
3026	21	1808	1826	160	1.3/16	7321		0		VTD7 1817			
3027	201	1829	1847	164	1.2/15	7311		0		Hobbs = 3.7			
3028	21	1850	1908	155	1.0/17	7356		0		1114 B ONLINE = 2.8			
3029	201	1913	1929	164	1.1/17	7250		0		Mob = 1.0			
3030	21	1933	1948	158	1.2/16	7295		0		Unplanned (X' 3103 - 3105) Daily total			
Xtie	291	1952	1954	160	1.5/15	7297		0		Hobbs 7.1			
3103	53	1959	2000	168	1.3/16	8786		0		ONLINE 5.1			
3104	233	2004	2005	125	1.3/16	8741		0		Mob 2.0			
3105	53	2014	2015	140	1.3/16	8767		0		Flyover (VTD7-2027)			
Xtie	318	2017	2018	140	1.3/17	8740		0					
3106	201	2034	2036	147	1.2/17	8587		0					
3107	21	2039	2041	157	1.2/17	8588		0					
3108	201	2045	2047	155	1.1/18	8457		0					
Xtie	111	2051	2051	165	1.1/17	8546		0		Unplanned (X 3106-3108) (VTCL 2110) RFB low fuel (Fig 8's 2055-2101)			
3085													
3086													
3087													

Total Proj Lines: _____ Lines Flow: _____ Lines Remain: _____ Online Time: 2.8 Mob Time: _____ Notes: _____

Nov 15, 2016-A (N73TM, SN7178)

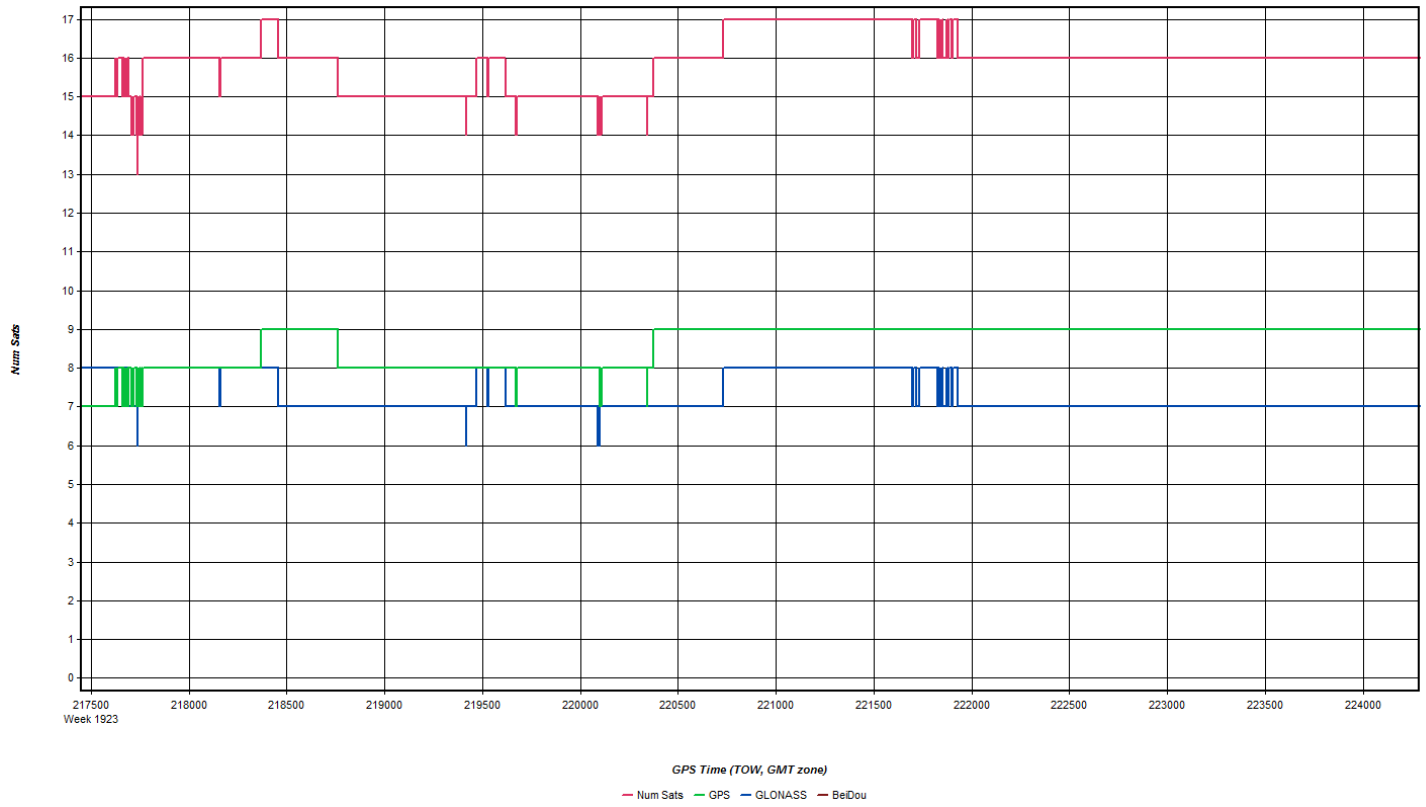
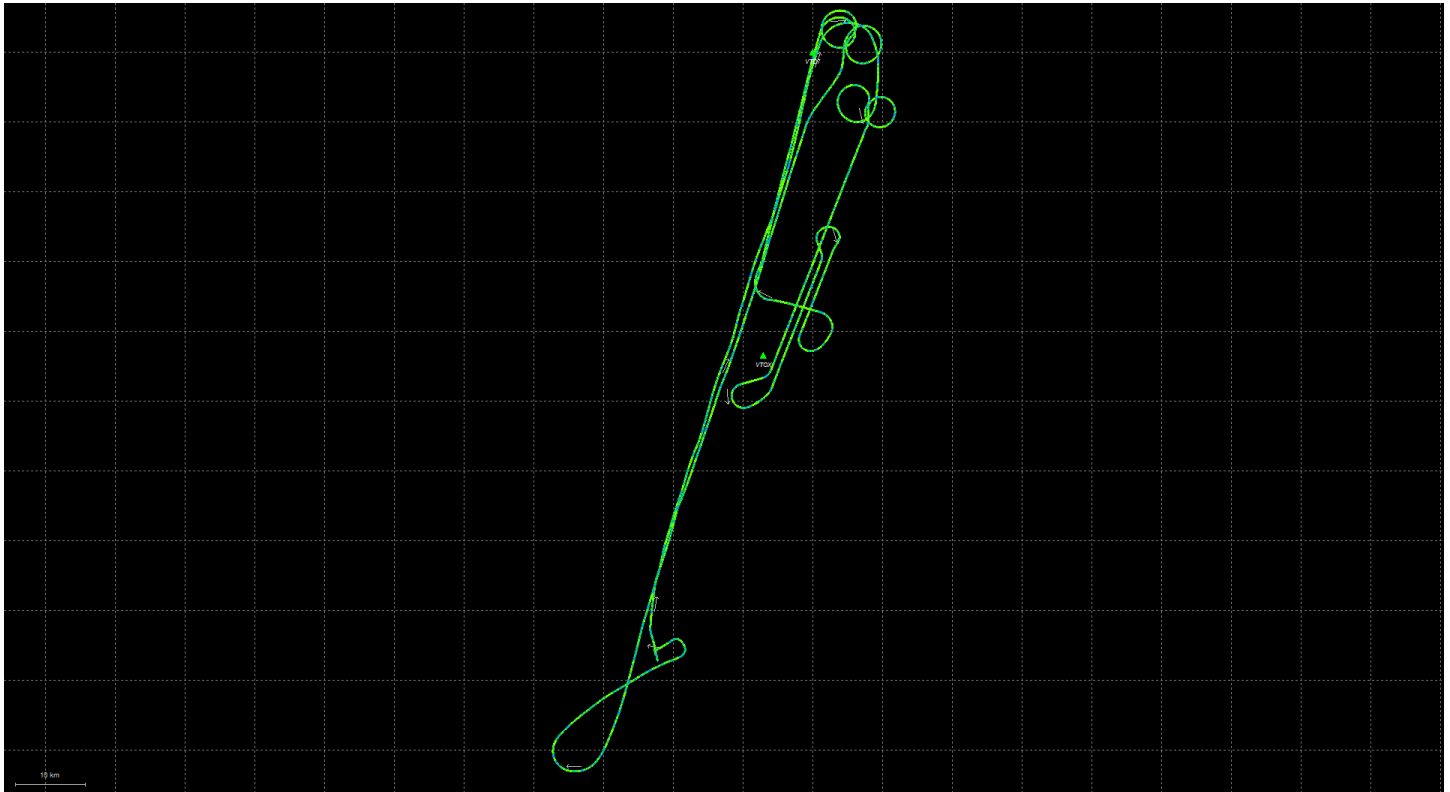

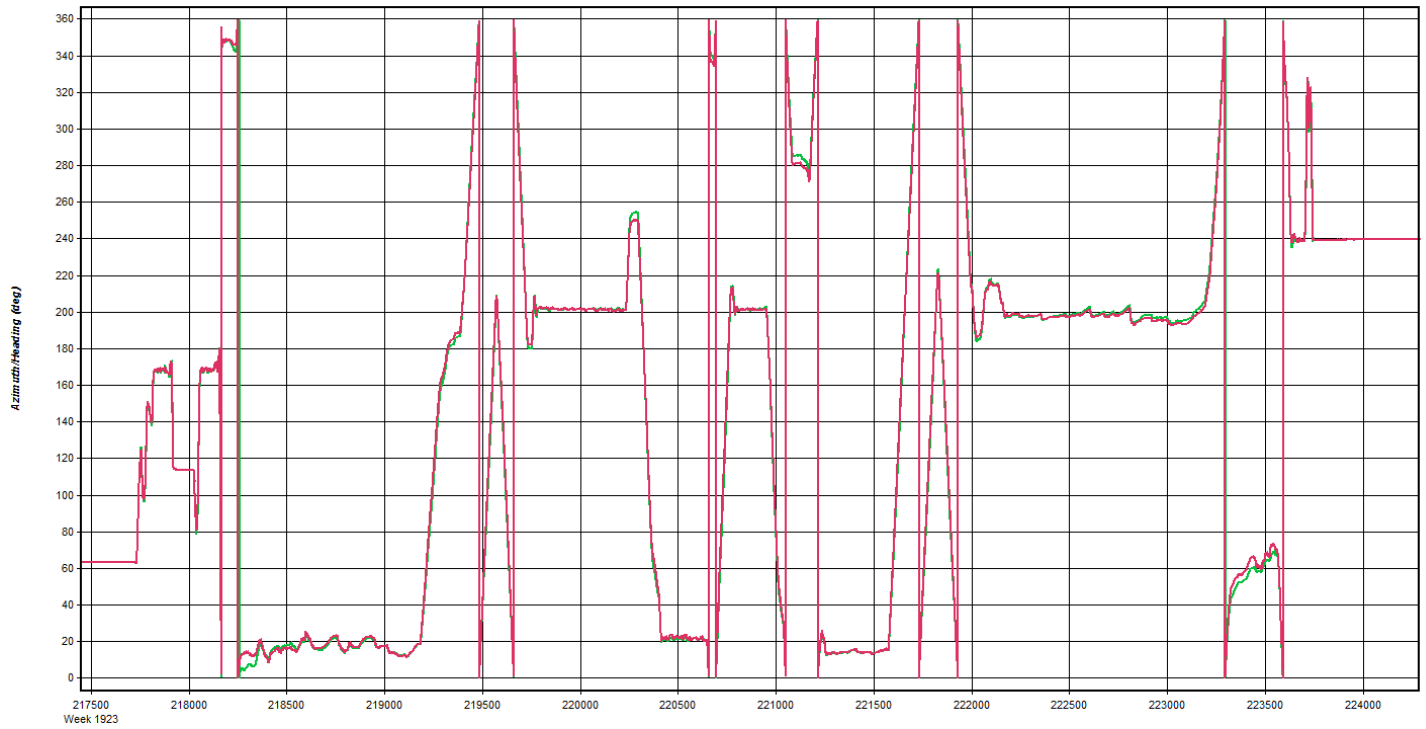
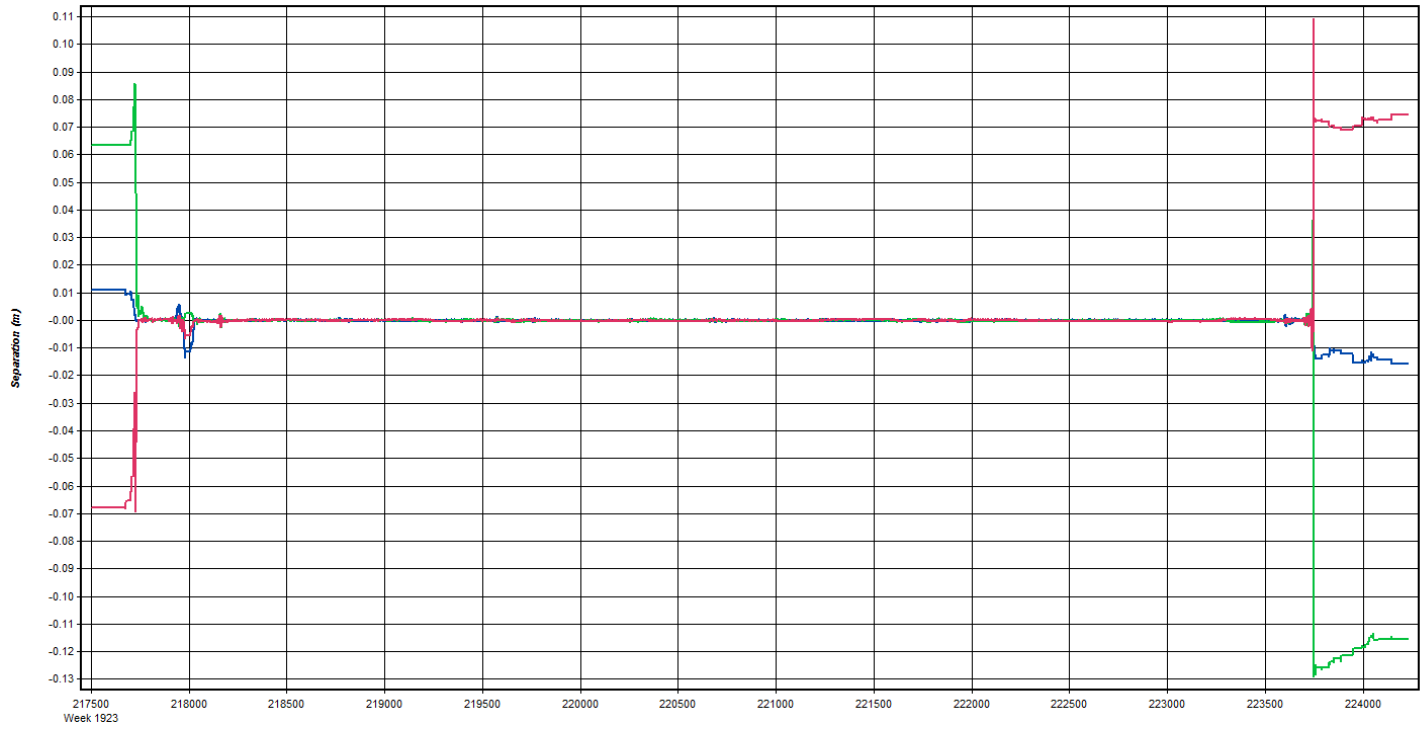

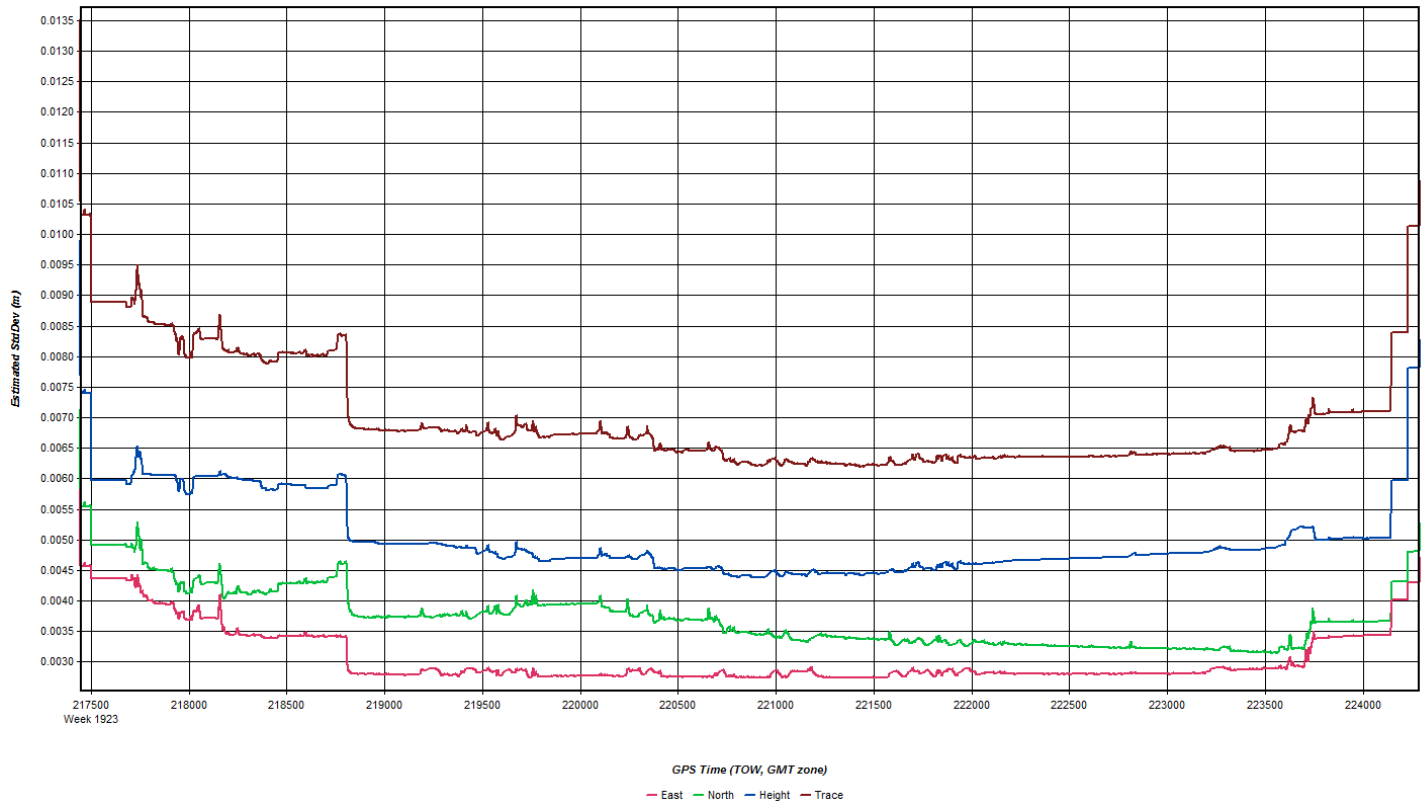



GPS Time (TOW, GMT zone)
— Roll — Pitch

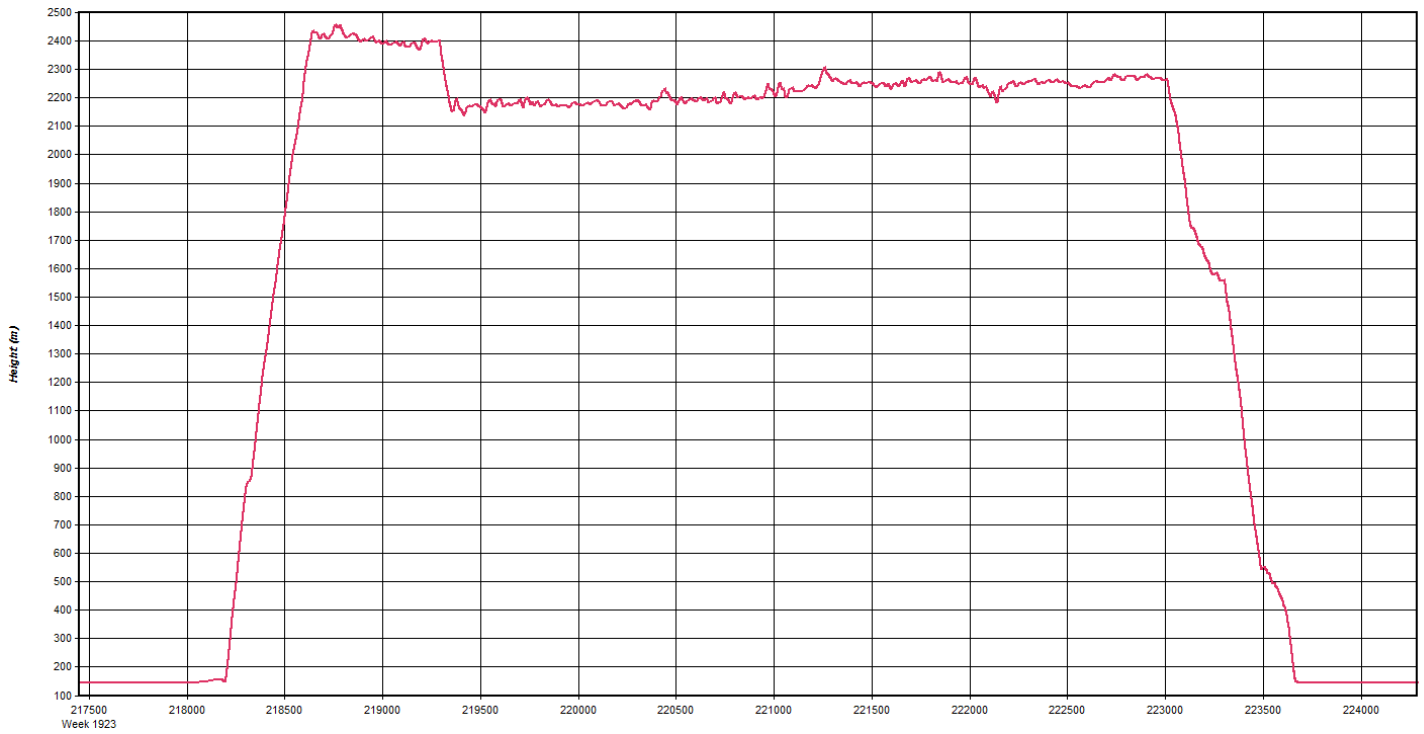

GPS Time (TOW, GMT zone)
— Height

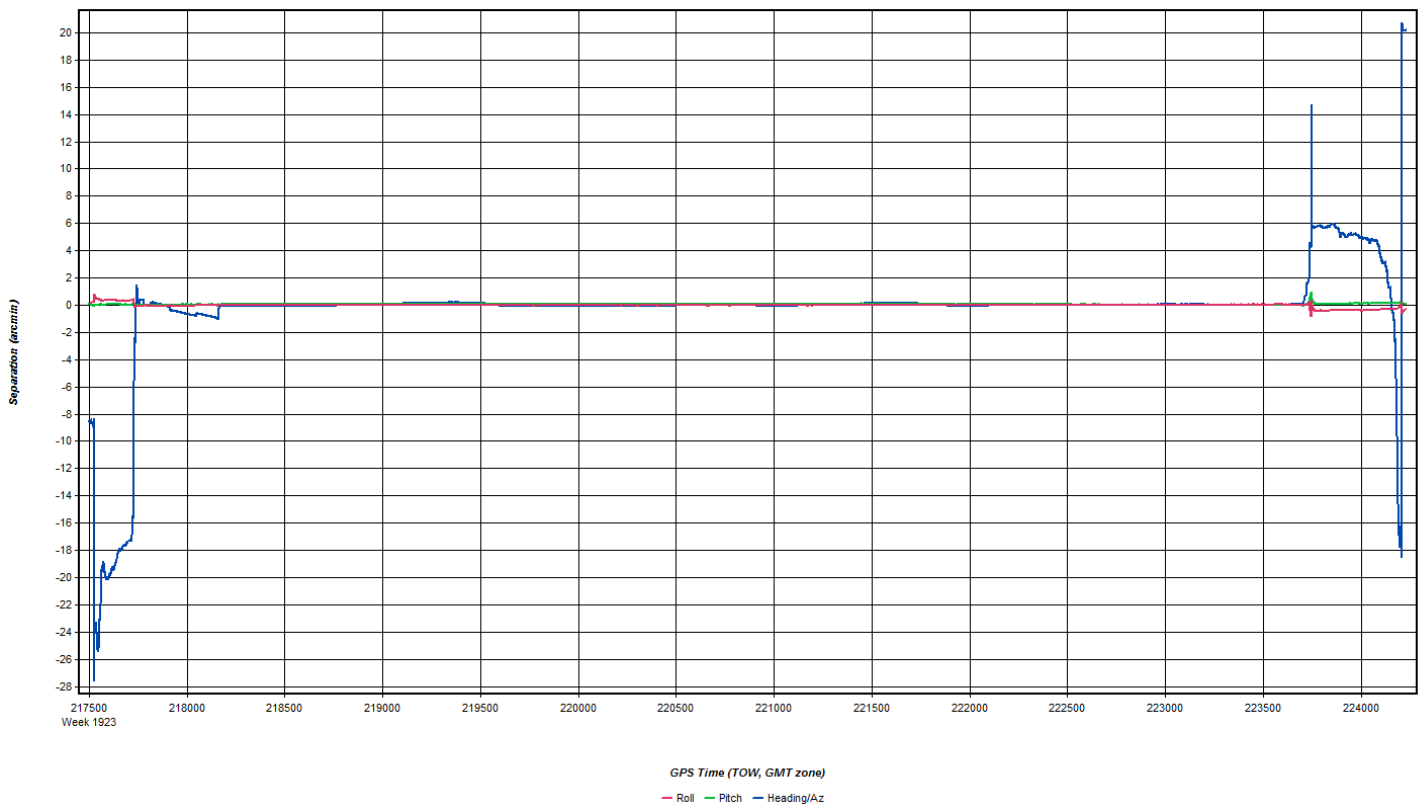

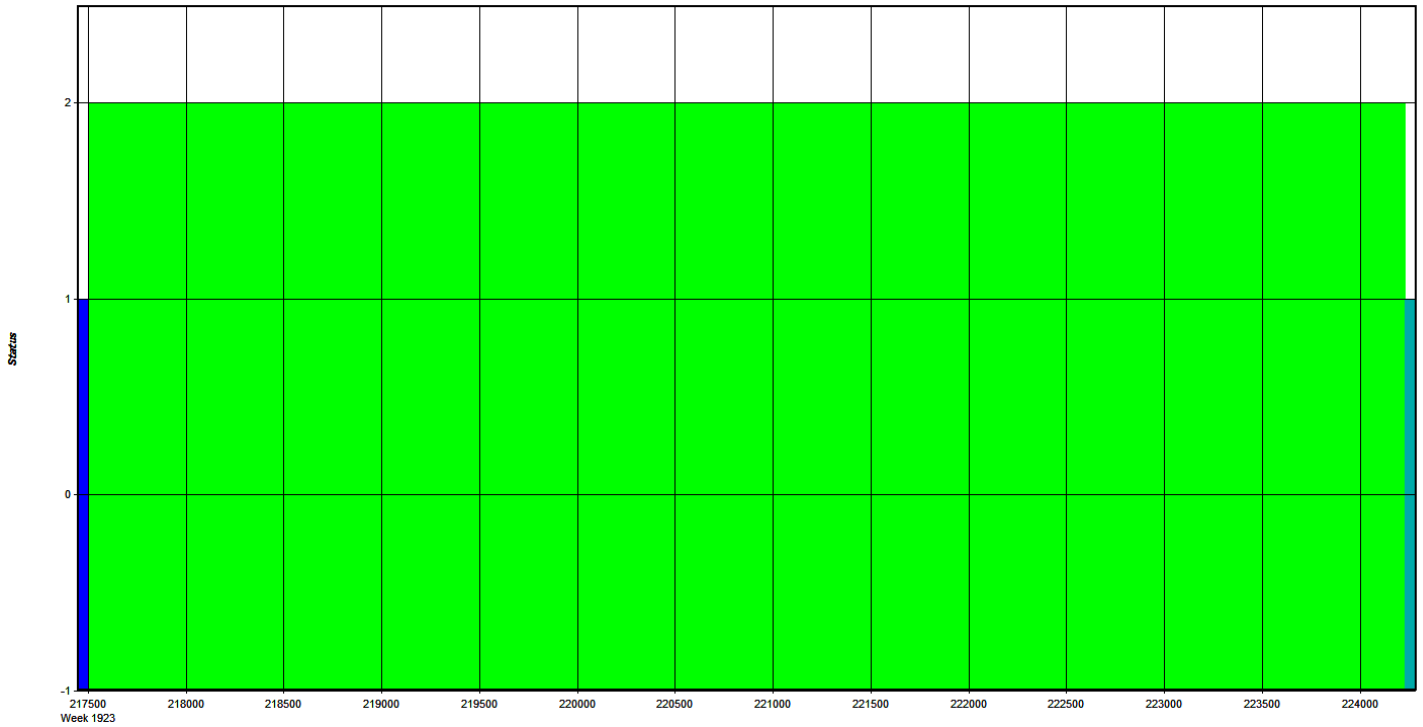

GPS Time (TOW, GMT zone)
 - Float - Forward Fixed - Reverse Fixed - Fixed (2 or more)

Coordinate/Antenna Settings

Master Remote

Base Station
 1: VTD7 Name: VTD7 Disabled
 File: E:\Proc\29178_VT_CT_River_Basin\20161115_A_29178_7178_1

Coordinates
 Latitude: North 44 23 52.31066 Compute from PPP
 Longitude: West 72 01 32.39267 Enter Grid Values
 Ellipsoidal height: 166.528 m Enter MSL Height
 Datum: WGS84 Datum Options
 Select From Favorites Add To Favorites Use Average Position

Antenna Height
 From station file: TRM55971.00, NONE View STA File
 Antenna profile: TRM55971.00 Info
 Measured height: 0.000 m
 ARP to L1 offset: 0.067 m
 Applied height: 0.067 m
 Measured to:
 ARP
 L1 Phase Centre
 Compute From Slant

OK Cancel

Coordinate/Antenna Settings ? X

Master Remote

Base Station
2: VTOX Name: VTOX Disabled
File: E:\Proc\29178_VT_CT_River_Basin\20161115_A_29178_7178_1

Coordinates
Latitude: North 44 00 28.16564 Compute from PPP
Longitude: West 72 06 51.60957 Enter Grid Values
Ellipsoidal height: 126.405 m Enter MSL Height
Datum: WGS84 Datum Options
Select From Favorites Add To Favorites Use Average Position

Antenna Height
From station file: TRM55971.00, NONE View STA File
Antenna profile: TRM55971.00 Info
Measured height: 0.000 m
ARP to L1 offset: 0.067 m
Applied height: 0.067 m
Measured to:
 ARP
 L1 Phase Centre
Compute From Slant

OK Cancel

Flight Log

Quantum Spatial Airborne LIDAR Data Collection Log Sheet :: Quantum Spatial, Inc
(email log daily to flight_log_distribution_list@quantumspatial.com)

Date: 11-15-16
 Lit: A B C D E Pg 1 of 1

Project: USGS CEFIVER LIDAR Proj #: 29178 Flight Mgmt File: 2016115-122126 Tech: M AUST
 Aircraft: 737M Begin Hobbs: 6501.0 End Hobbs: 6502.5 Total: 1.5 Pilot: J BARKHAM Co-Pilot:
 Dep Apt: LEB Dep Time (Ldt): 7:40 (Z): 12:40 Arr Apt: LEB Arr Time (Local): (Z): Tot Time Aloft:
 CORS: (Y) N Sta 1: VTD7 Flyovers: Y / N If Y, times: Sta1) 1252, 1330 Sta2)
 GPS Unit: Y / N Sta 1: Sta 2: Flyovers: Y / N If Y, times: Sta1) Sta2)

Line #	Hdg	Start (UTC)	End (UTC)	Gd Spd	POOP/sens	GPS Altitude	Crab	Turb (0-1)	Alt AGL	Alt AMSL	AvG Terr Ht	Max Gdspd	Avg Pt Spacing	end: 3004	Bag CB	End CB	Tot CB	Storing Name
3085	201°	1307	1310	155	1.1/18	7.2			718	7.2								4
3086	21°	1313	1317	166	1.0/18	7.2												
3087	201°	1320	1322	155	1.1/18	7.2												
41001	21°	1324	1325	162	1.2/17	7.3												

FLIGHT LINE NOTES - visibility, clouds, smoke, partial, etc.

Total Proj Lines: Lines Flown: Lines Remain: Online Time: 5 Mob Time: 1 Notes:

Nov 18, 2016-A (N22GE, SN7161)

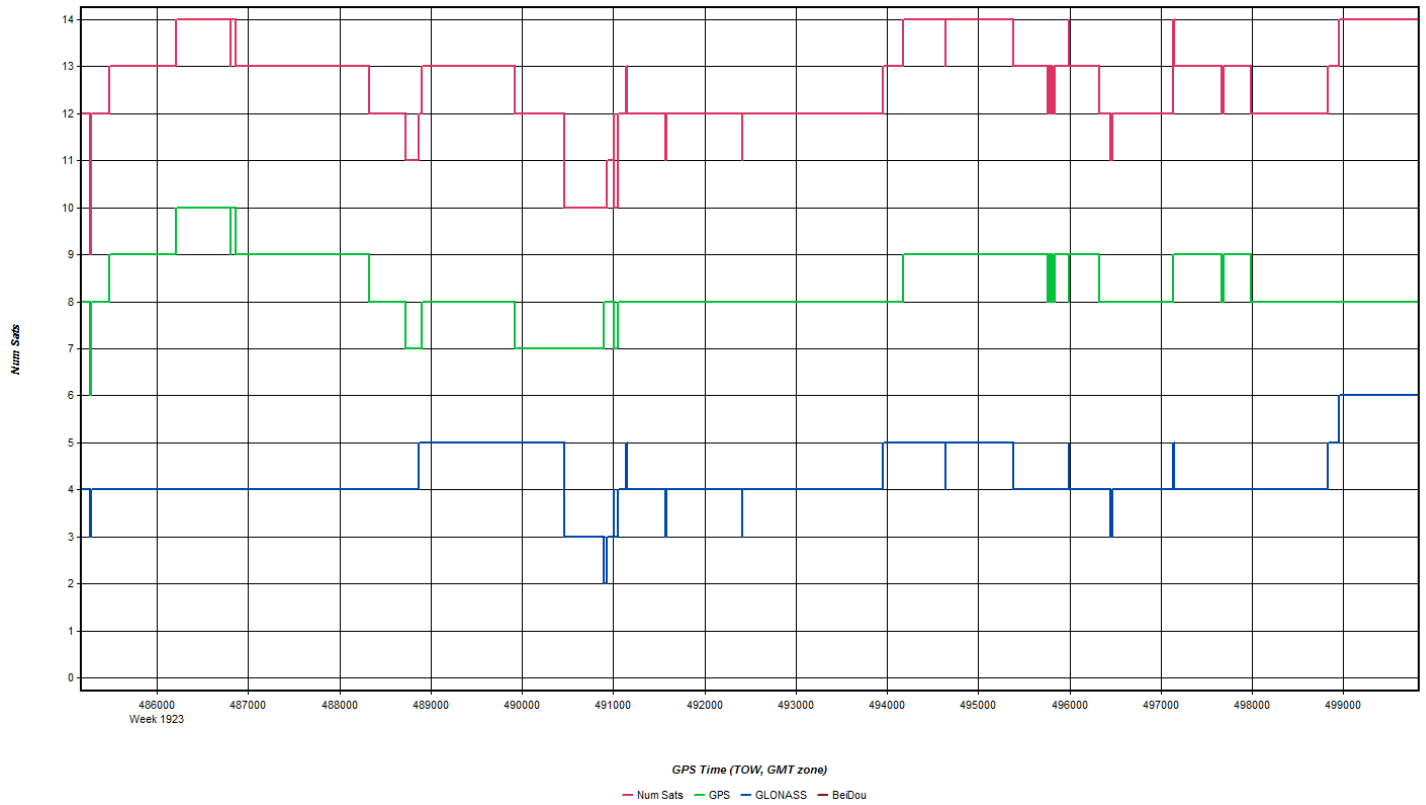
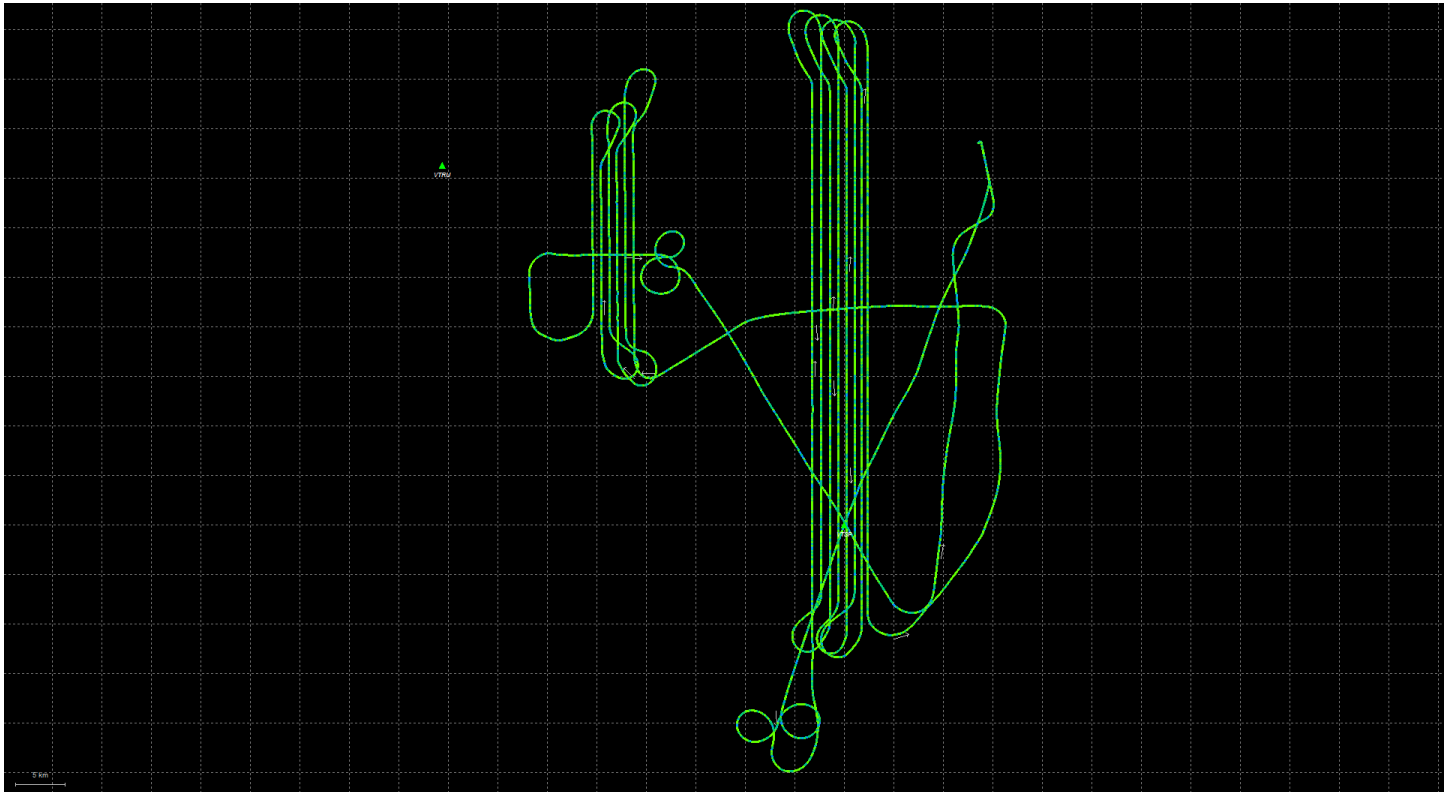

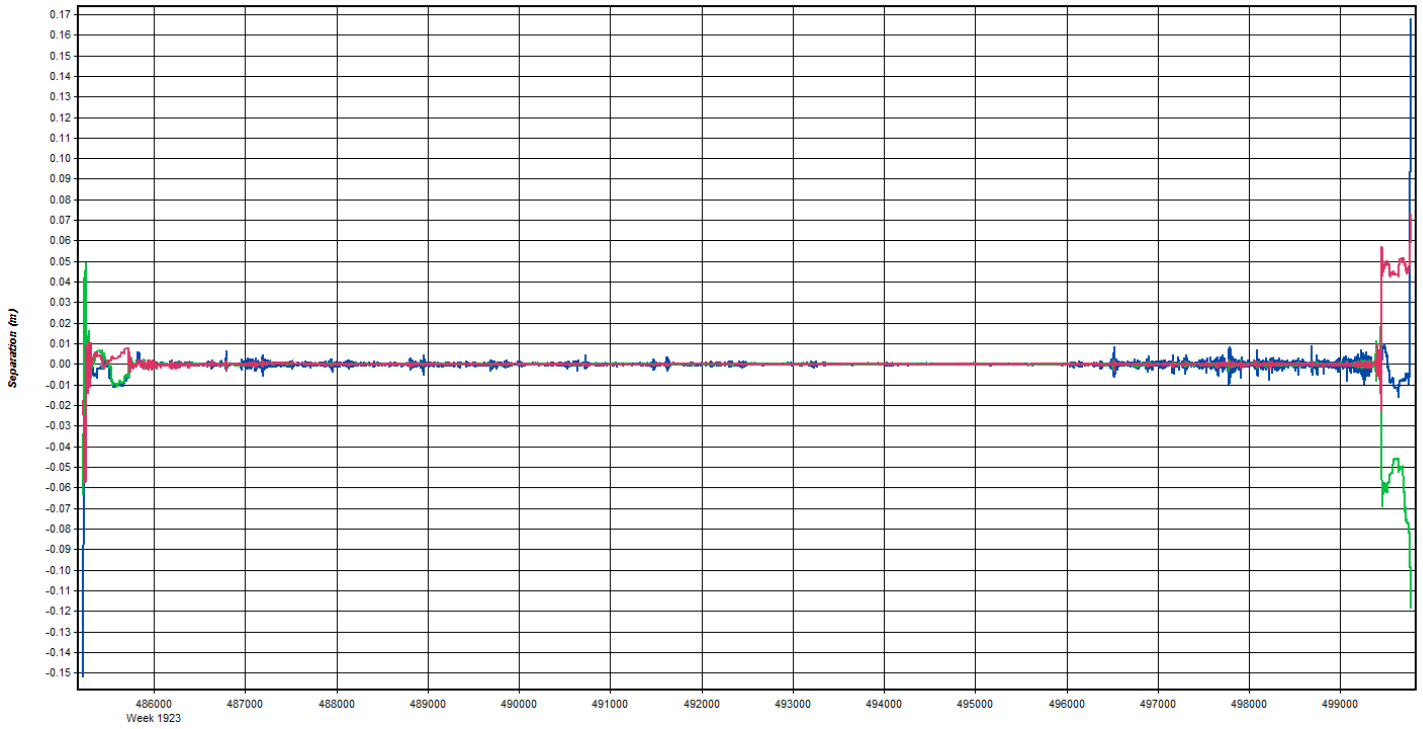

GPS Time (TOW, GMT zone)
— East — North — Up

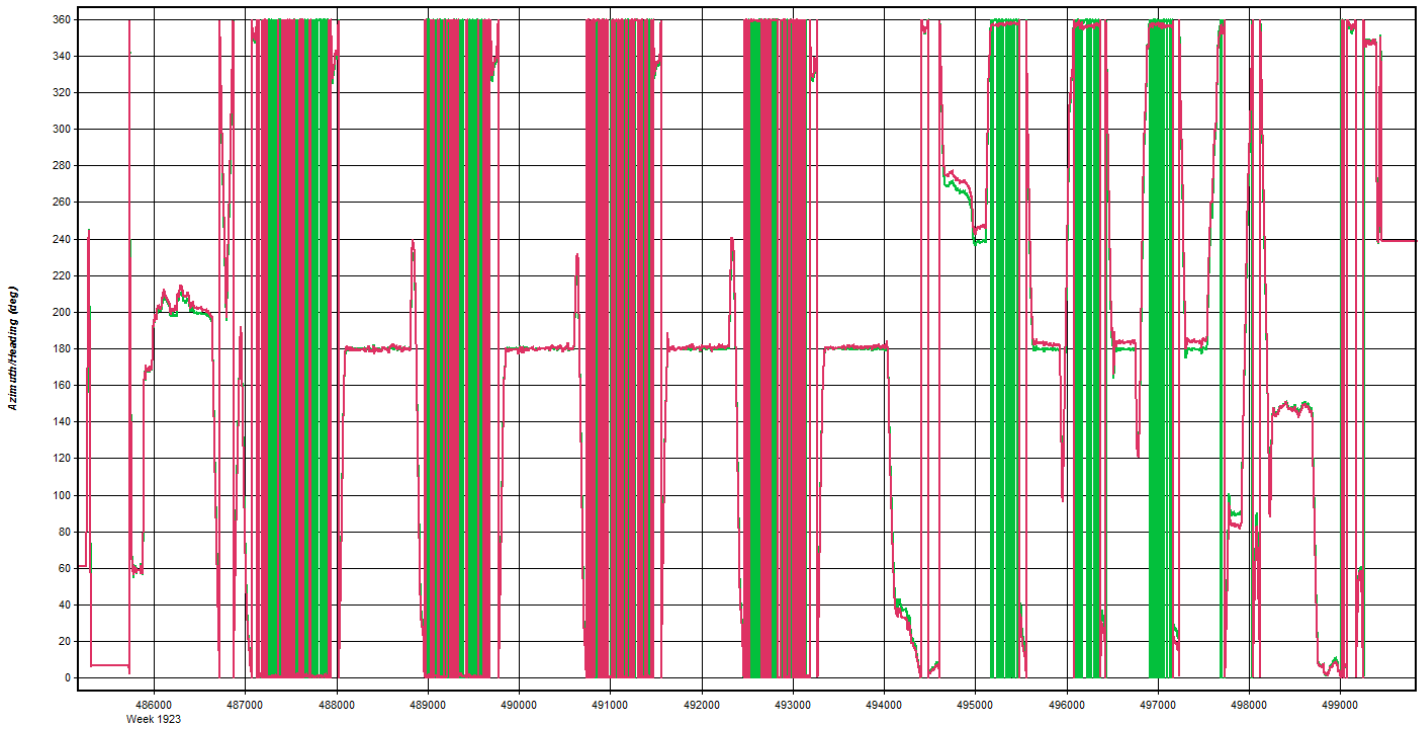

GPS Time (TOW, GMT zone)
— Heading/Azimuth — GPS-COG

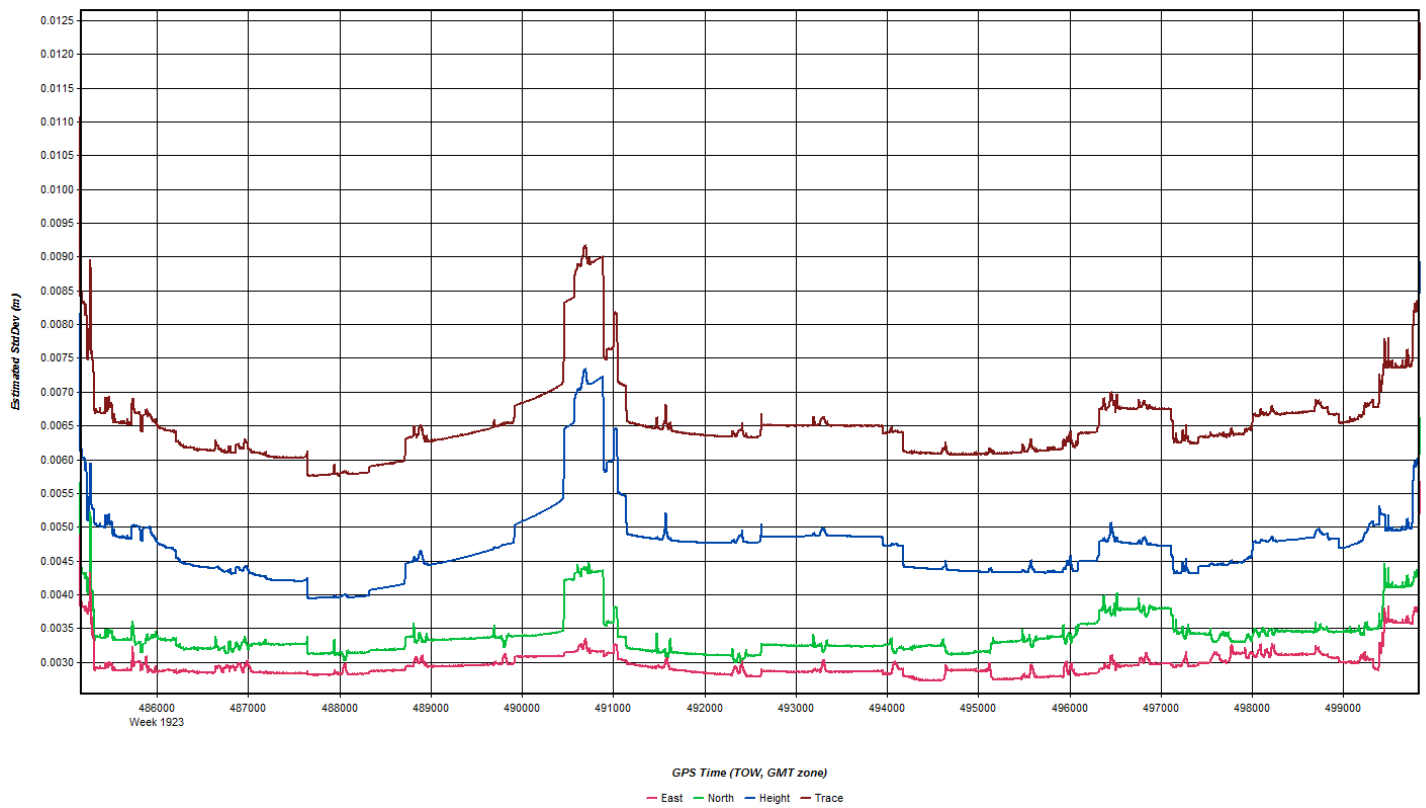
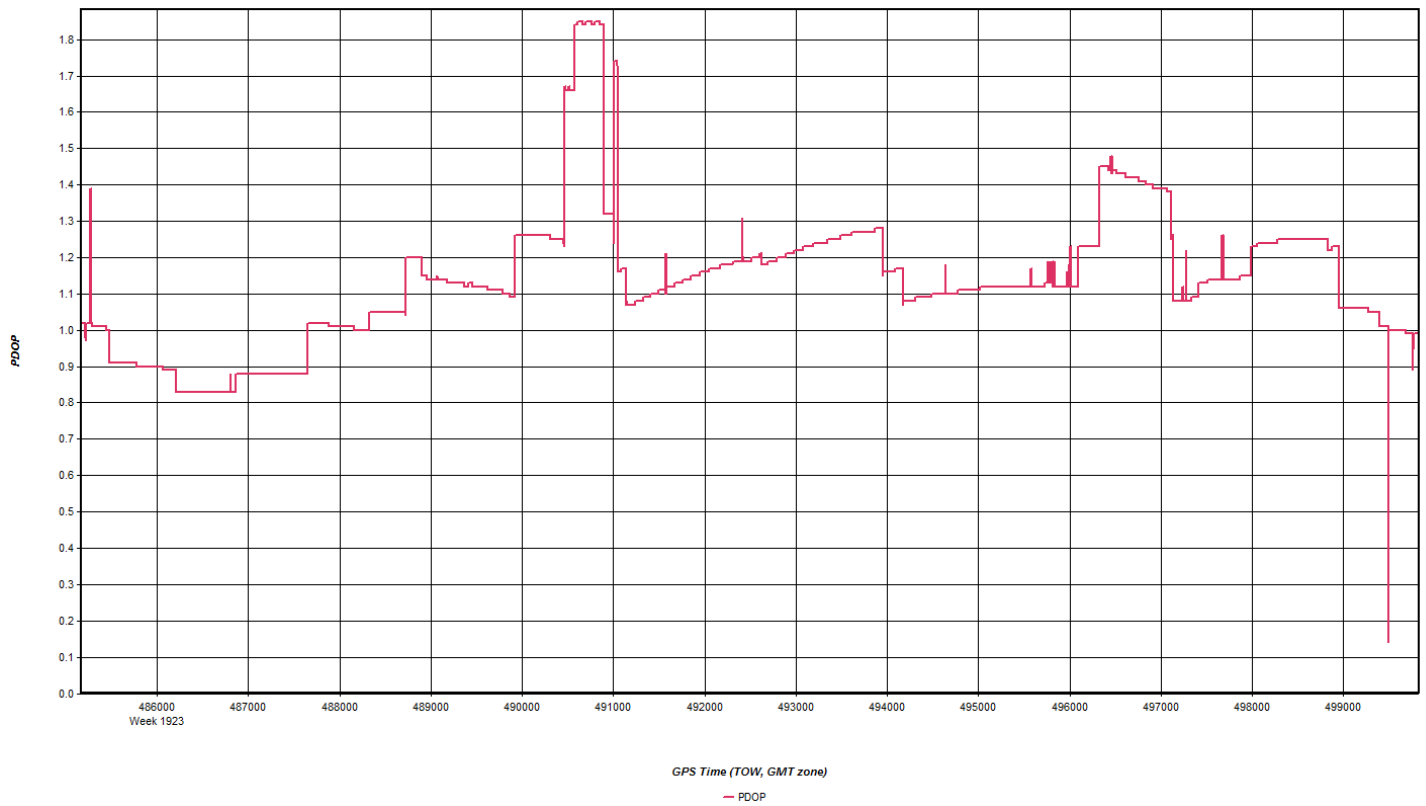

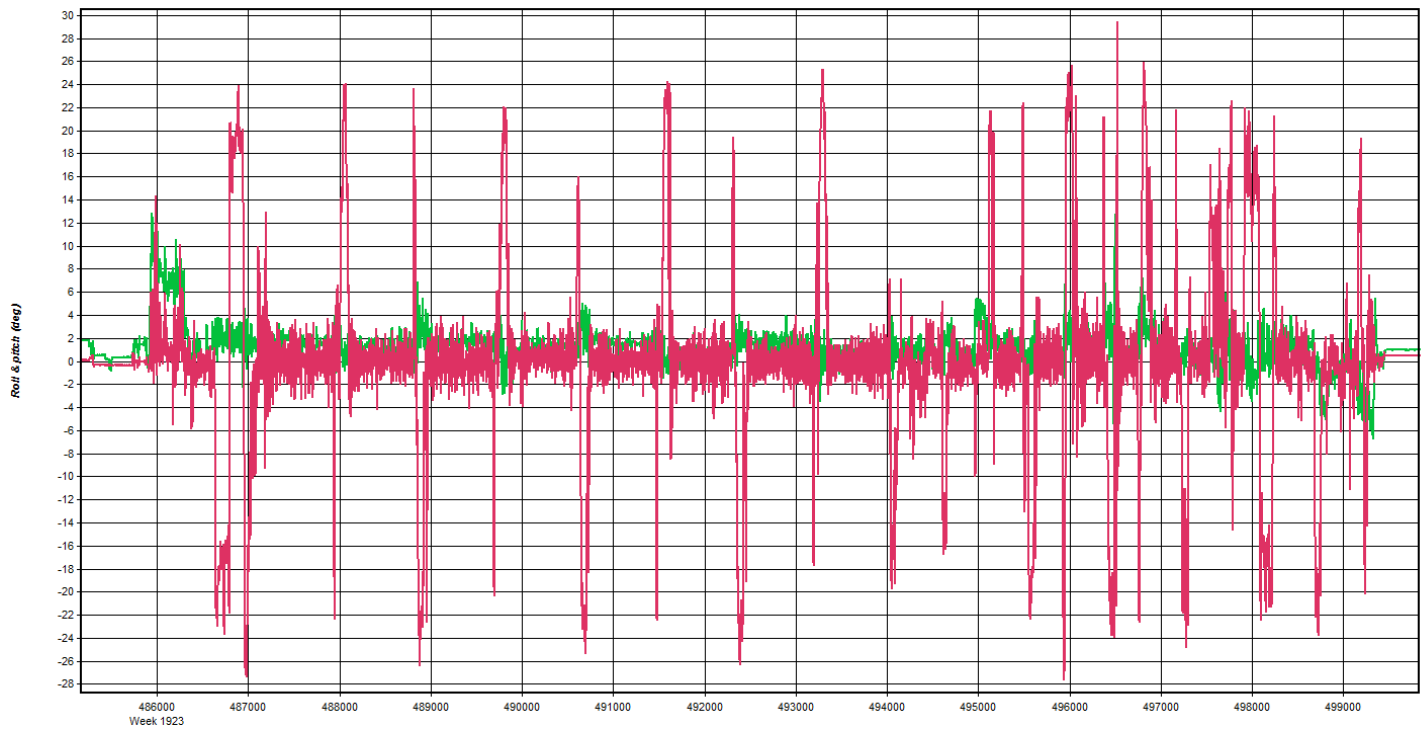

GPS Time (TOW, GMT zone)

— Roll — Pitch

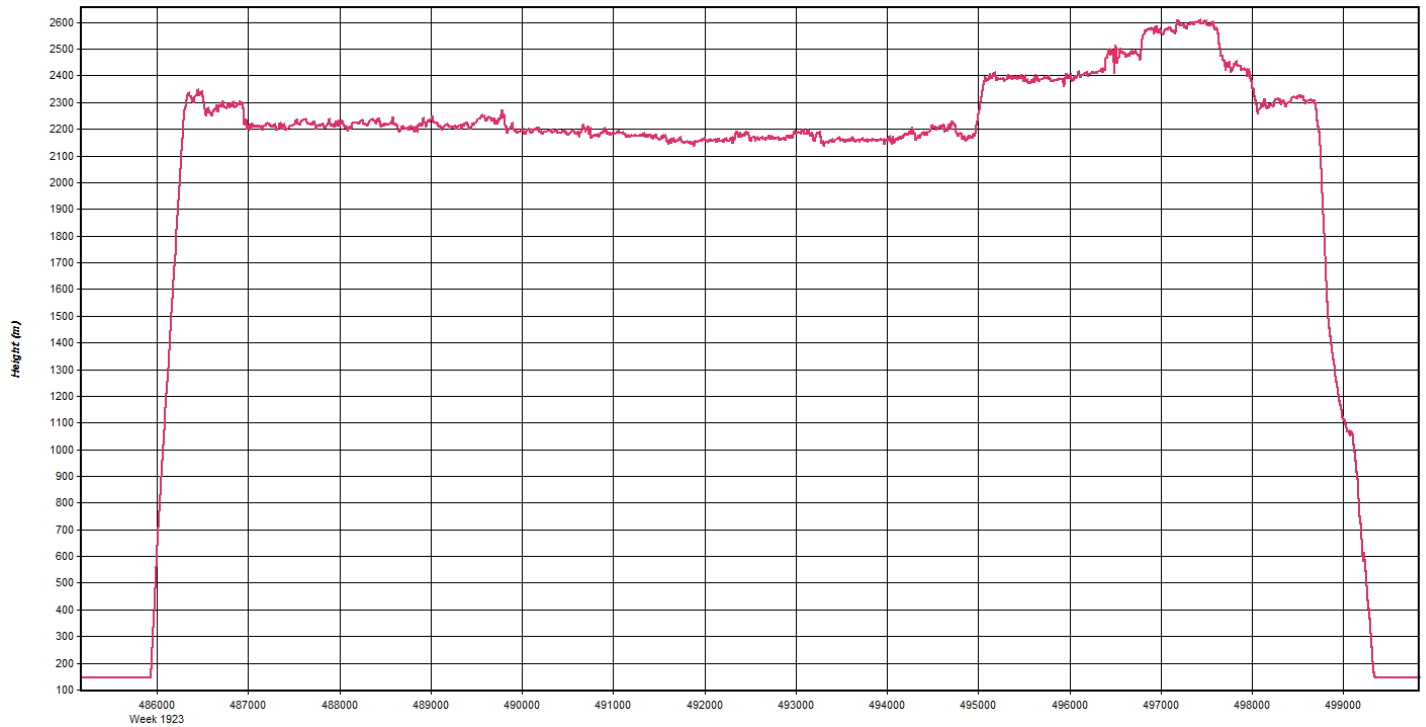

GPS Time (TOW, GMT zone)

— Height

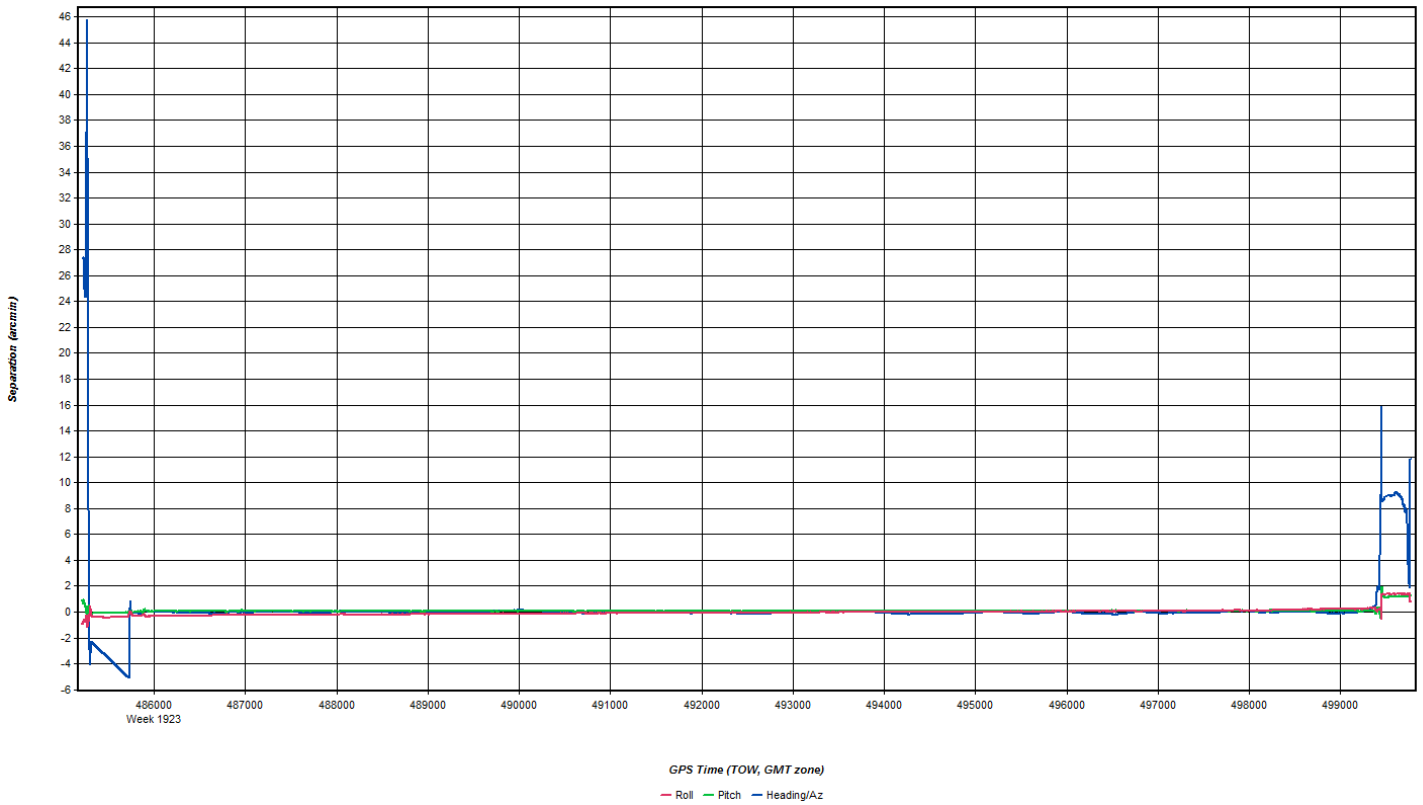
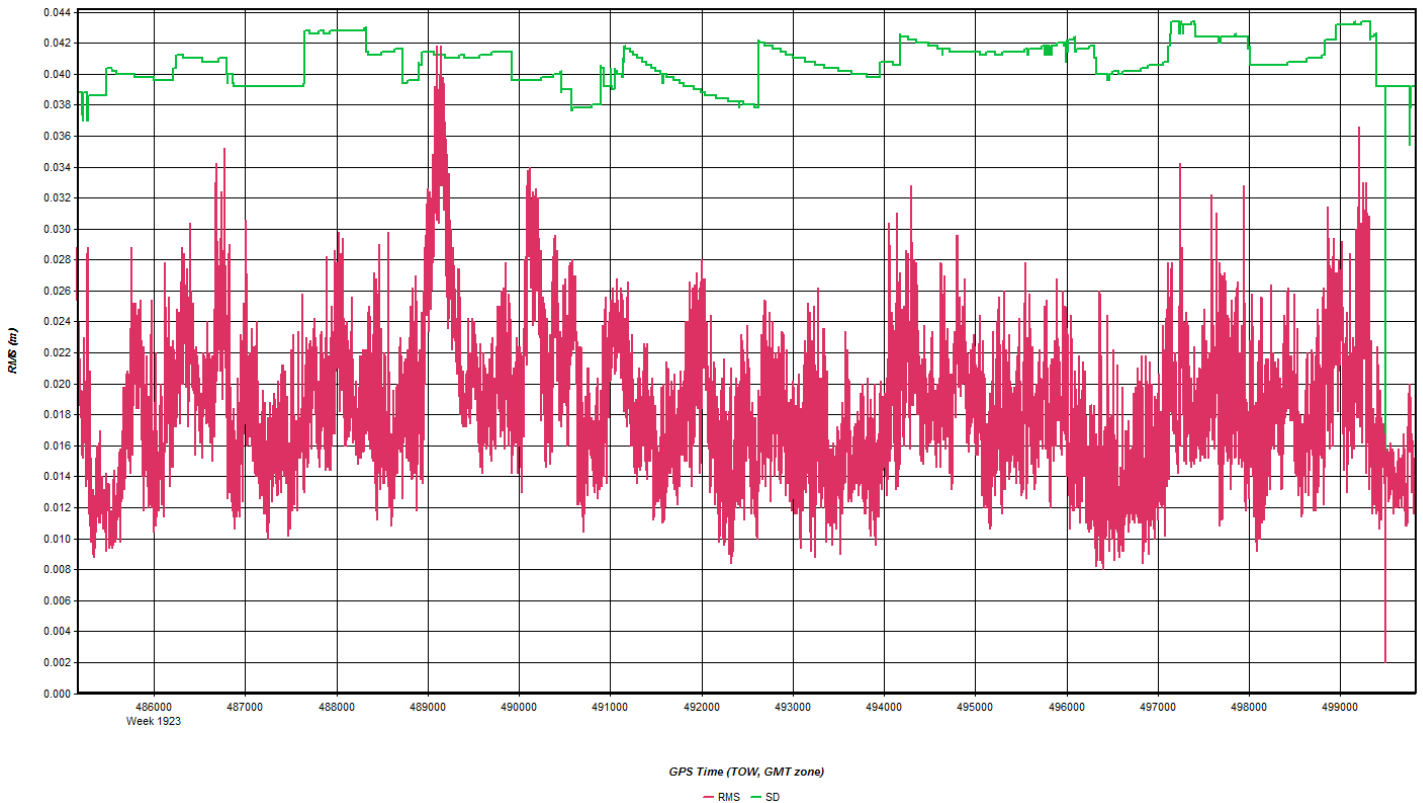

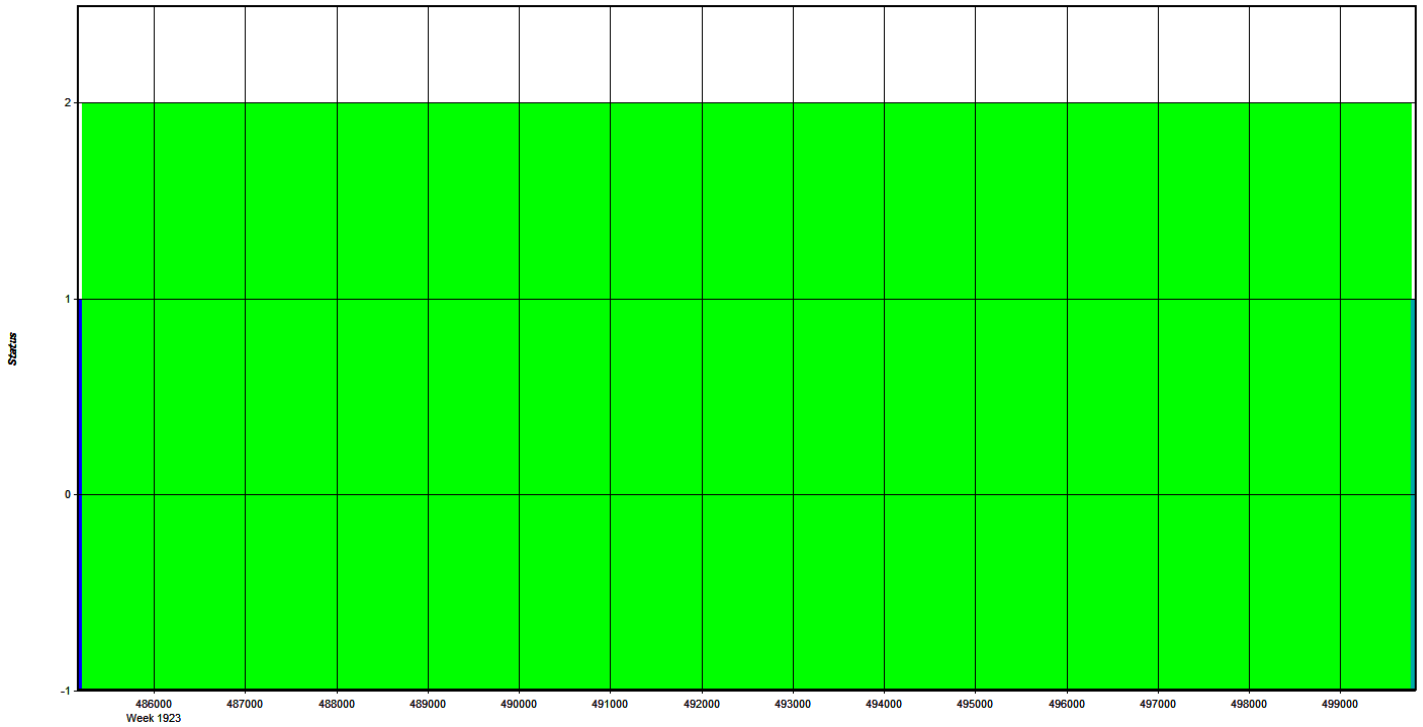

GPS Time (TOW, GMT zone)
 - Float - Forward Fixed - Reverse Fixed - Fixed (2 or more)

Coordinate/Antenna Settings

Master Remote

Base Station
 2: VTRU Name: VTRU Disabled
 File: E:\Proc\29178_CT_River\20161118_A_B_29178_SN7161_N22G

Coordinates
 Latitude: North 43 36 25.63963 Compute from PPP
 Longitude: West 72 58 45.90373 Enter Grid Values
 Ellipsoidal height: 161.449 m Enter MSL Height
 Datum: WGS84 Datum Options
 Select From Favorites Add To Favorites Use Average Position

Antenna Height
 From station file: TRM57971.00, NONE View STA File
 Antenna profile: TRM57971.00 Info
 Measured height: 0.000 m
 ARP to L1 offset: 0.067 m
 Applied height: 0.067 m
 Measured to
 ARP
 L1 Phase Centre
 Compute From Slant

OK Cancel

Coordinate/Antenna Settings

Master Remote

Base Station
1: VTSP Name: VTSP Disabled
File: E:\Proc\29178_CT_River\20161118_A_B_29178_SN7161_N22G

Coordinates
Latitude: North 43 16 53.24114 Compute from PPP
Longitude: West 72 28 39.23841 Enter Grid Values
Ellipsoidal height: 156.441 m Enter MSL Height
Datum: WGS84 Datum Options
Select From Favorites Add To Favorites Use Average Position

Antenna Height
From station file: TRM55971.00, NONE View STA File
Antenna profile: TRM55971.00 Info
Measured height: 0.000 m
ARP to L1 offset: 0.067 m
Applied height: 0.067 m
Measured to:
 ARP
 L1 Phase Centre
Compute From Slant

OK Cancel

Flight Log

Scanned by CamScanner

Airborne LIDAR Data Collection Log Sheet :: Quantum Spatial, Inc
(email log daily to flight_log_distribution_list@quantumspatial.com)

Date: 11-18-16
 Lift: A B C D E Pg / of 2

Project: CT River VT
 Flight Mgmt File: 2016118-144131
 Tech: JSWAN

Aircraft: N226E Begin Hobbs: 8973.3 End Hobbs: 8977.0 Total: 3.7
 Pilot: Carl Christy, Co-Pilot:
 Dep Apt: KLEB Dep Time (Lcl): 1000 (Z): +5 Arr Apt: KLEB Arr Time (Local): 14:15
 Tot Time Aloft: 3.8

CORS: (Y)N Sta 1: VTSP/1507Z Sta 2: 1829
 Flyovers: (Y)N IF Y, times: Sta1) Sta2)
 GPS Unit: Y/N Sta 1: 10 Sta 2:

Gd Temp beg: +8 °C End: +8 °C OAT beg: +7 °C End: +8 °C Altimeter begin: 3011 end: 3008

LIDAR	Type	FOV	Semit #	Scan Freq	Alt AGL	MplA	Y	N	Pulses In Air	Avg Terr Ht	Pulse Rate	Max Gdspd	Power	AVG Pt Spacing	PPSM	Mag CB	End CB	Tot CB	Storage Name
1036	0°	1520	1531	144	12/11	7257	+2	0											
1037	180°	1535	1546	149	12/15	7302	+1	0											
1038	0°	1550	1601	129	10/17	7313	+1	0											
1039	180°	1605	1616	142	12/15	7206	-1	0											
1040	0°	1619	1631	135	10/19	7146	0	0											
1041	180°	1634	1644	155	11/16	7100	0	0											
1042	0°	1648	1659	141	13/16	7132	0	0											
1043	180°	1706	1712	157	12/18	7068	0	0											
X+ve	273	1724	1728	150	12/17	7280	0	0											
1065	360	1733	1737	141	12/17	7339	0	0											
1064	180	1741	1745	163	11/17	7332	0	0											
1063	360	1748	1752	133	12/17	7223	-2	0											
1062	180	1755	1758	153	11/18	8107	0	0											
1061	360	1802	1805	132	11/17	8483	0	0											
1060	180	1809	1811	131	12/16	8514	0	0											
1097	90	1816	1817	157	12/16	8055	0	0											
		1818	1828																

LEB → Flight's 1510 - 1514
 11/18/16 { Hobbs = 3.7
 Online = 3.0
 Mob = 0.7

unplanned
 traffic - 5 top Bank
 Planned X+ve
 Flight's - (1818-1823) - VTSP - (1829) - LEB

Total Proj Lines: 1818-1828
 Lines Remain: 0
 Lines Flow: 0
 Online Time: 3.0
 Mob Time: 0.7
 Notes:

Nov 18, 2016-B (N22GE, SN7161)

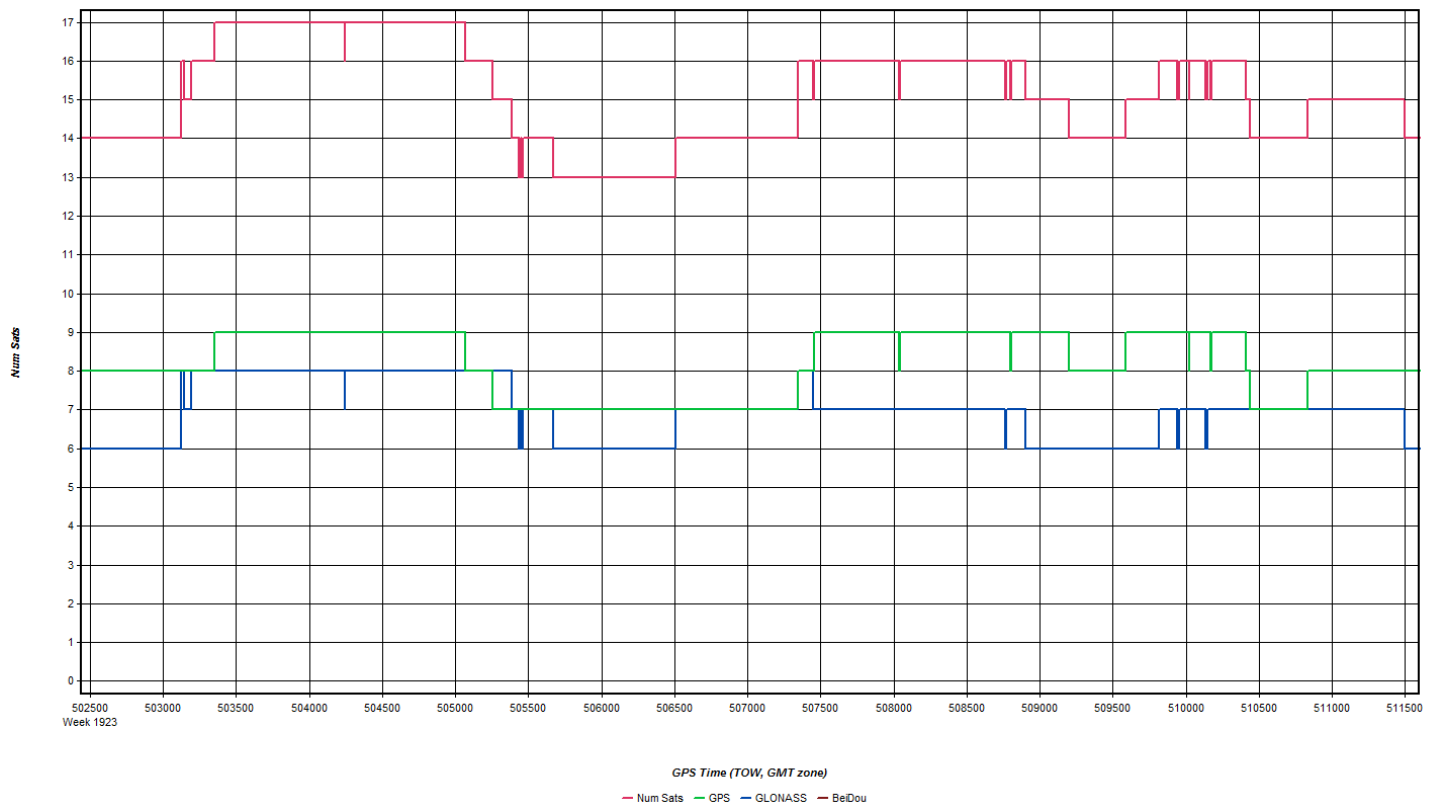
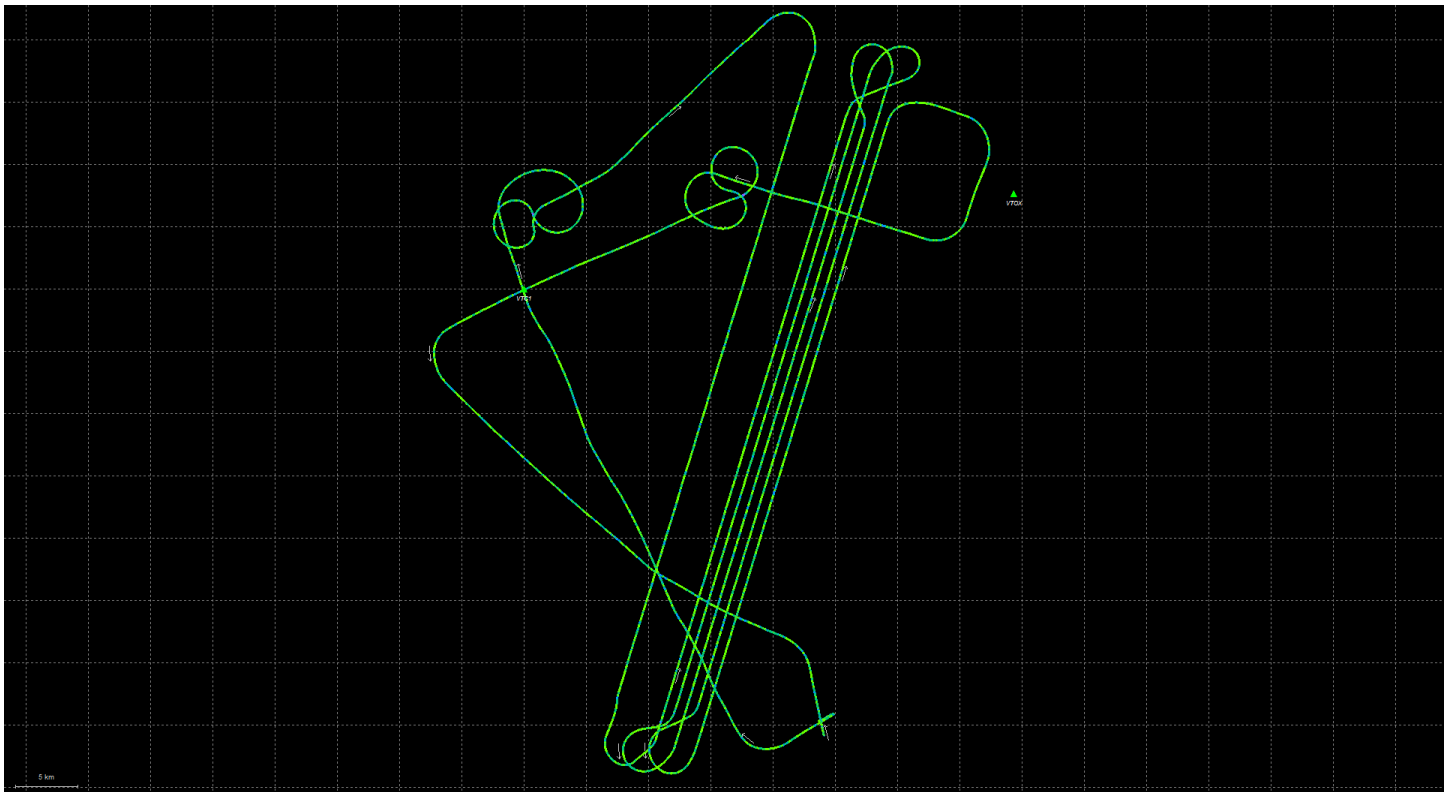

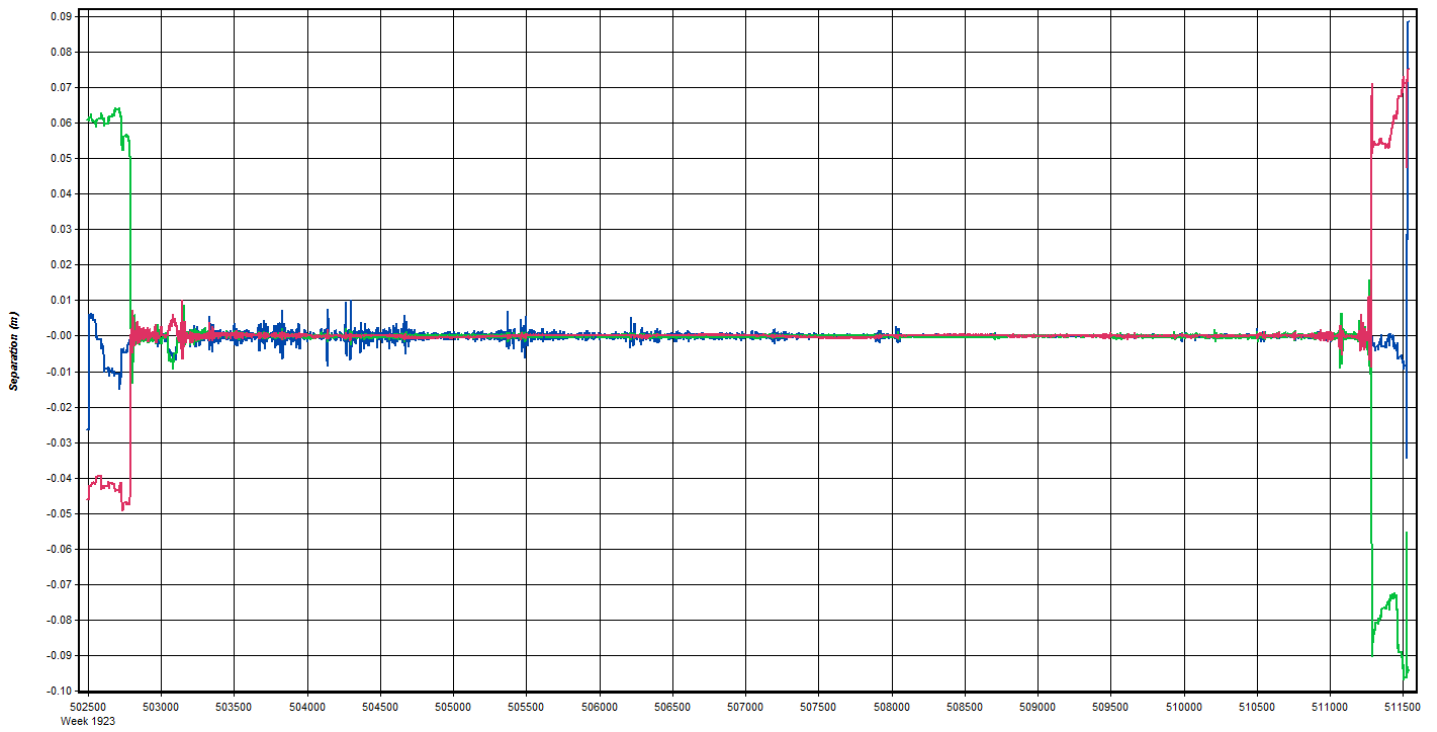

GPS Time (TOW, GMT zone)
— East — North — Up

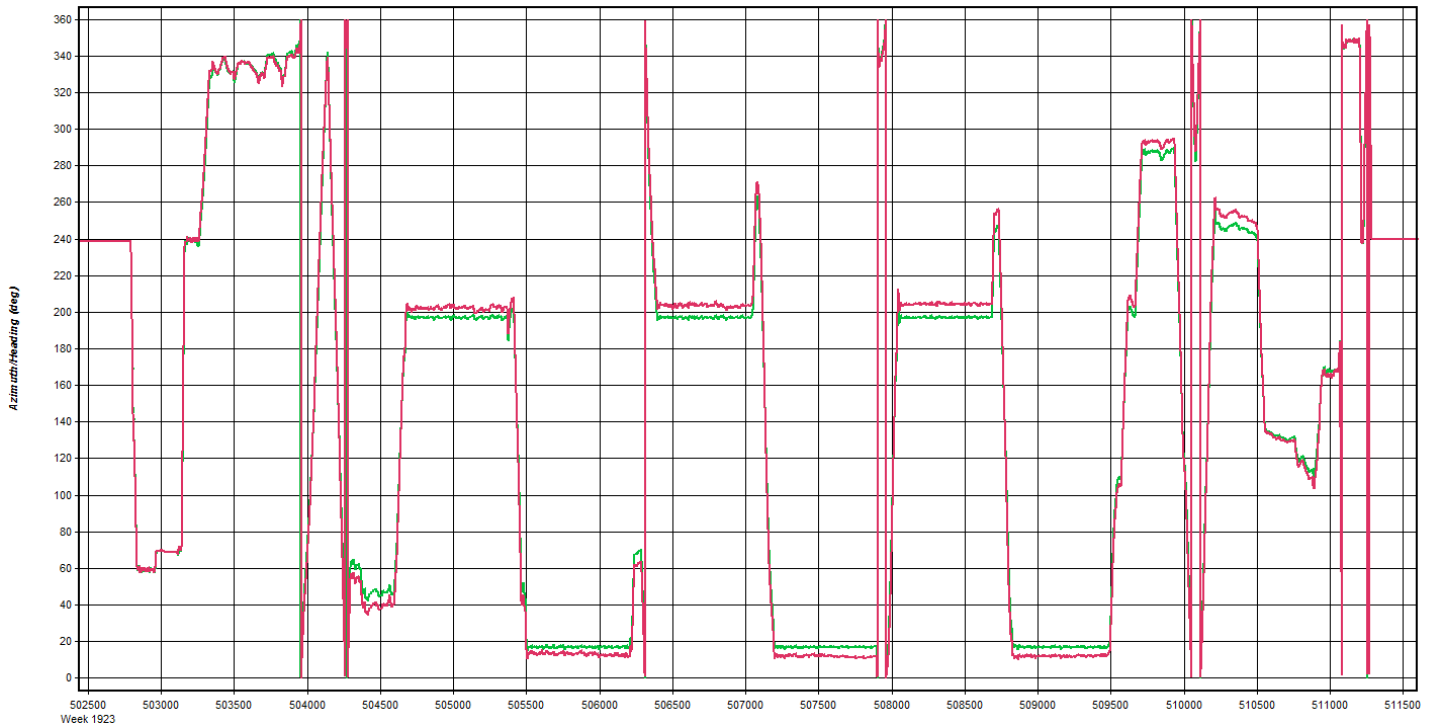

GPS Time (TOW, GMT zone)
— Heading/Azimuth — GPS-COG

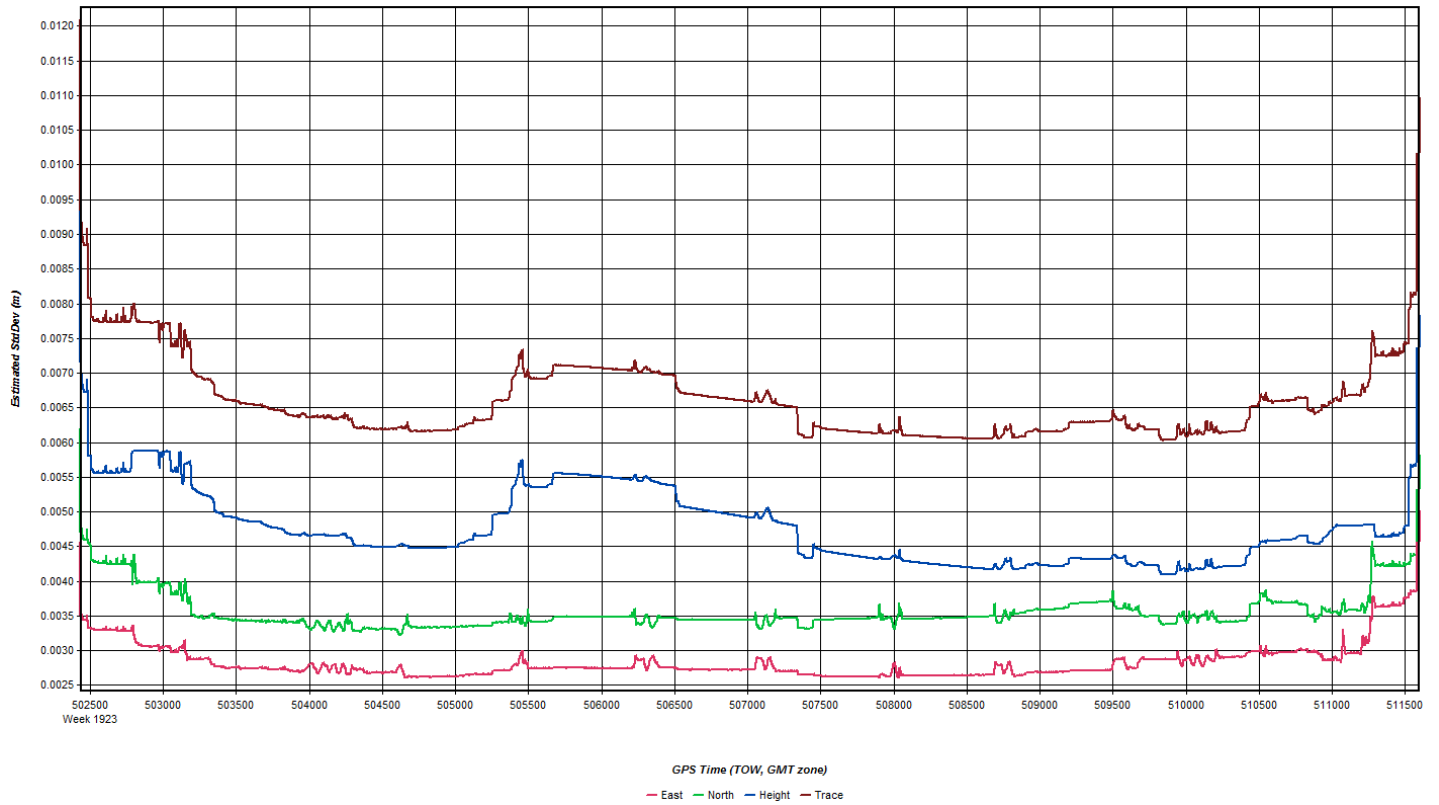
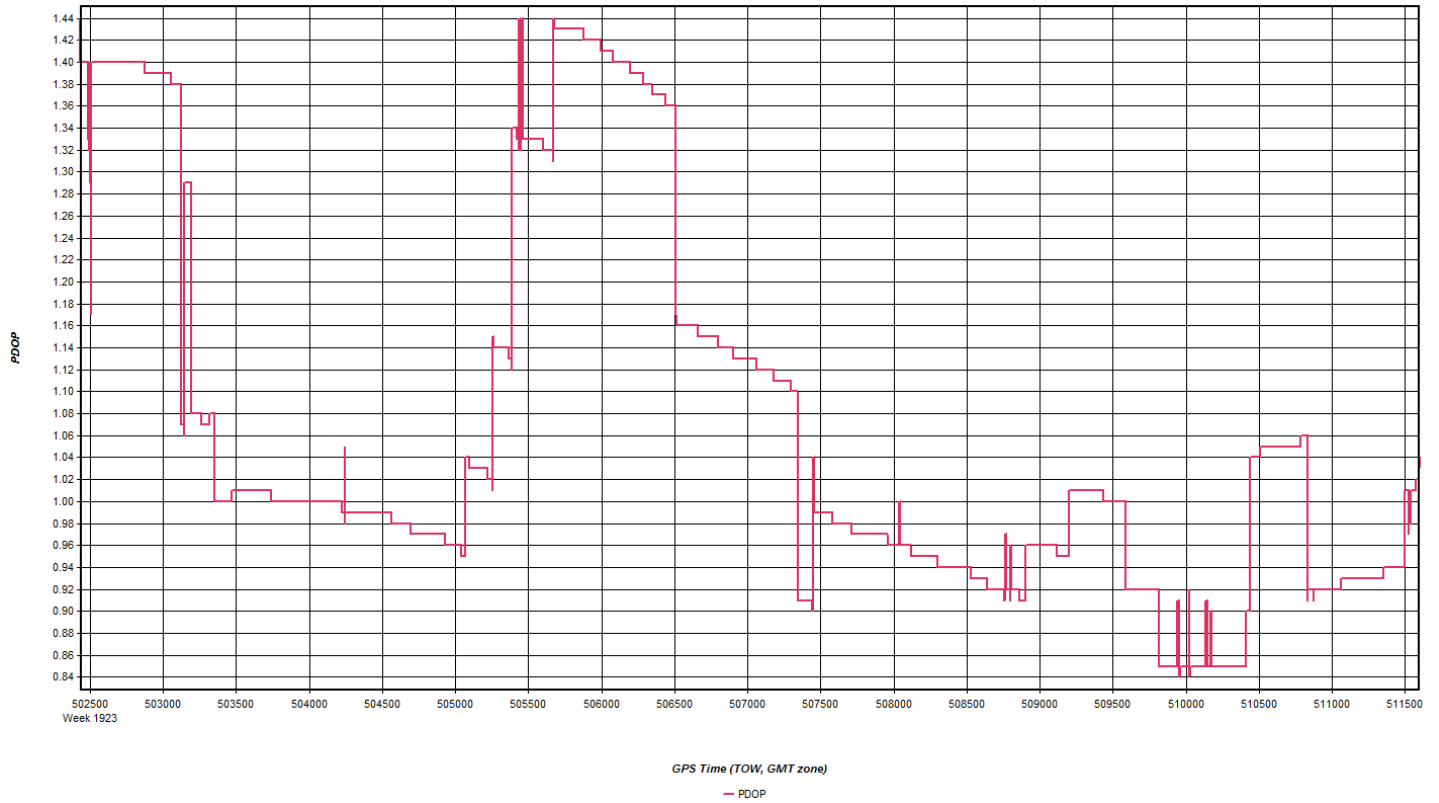

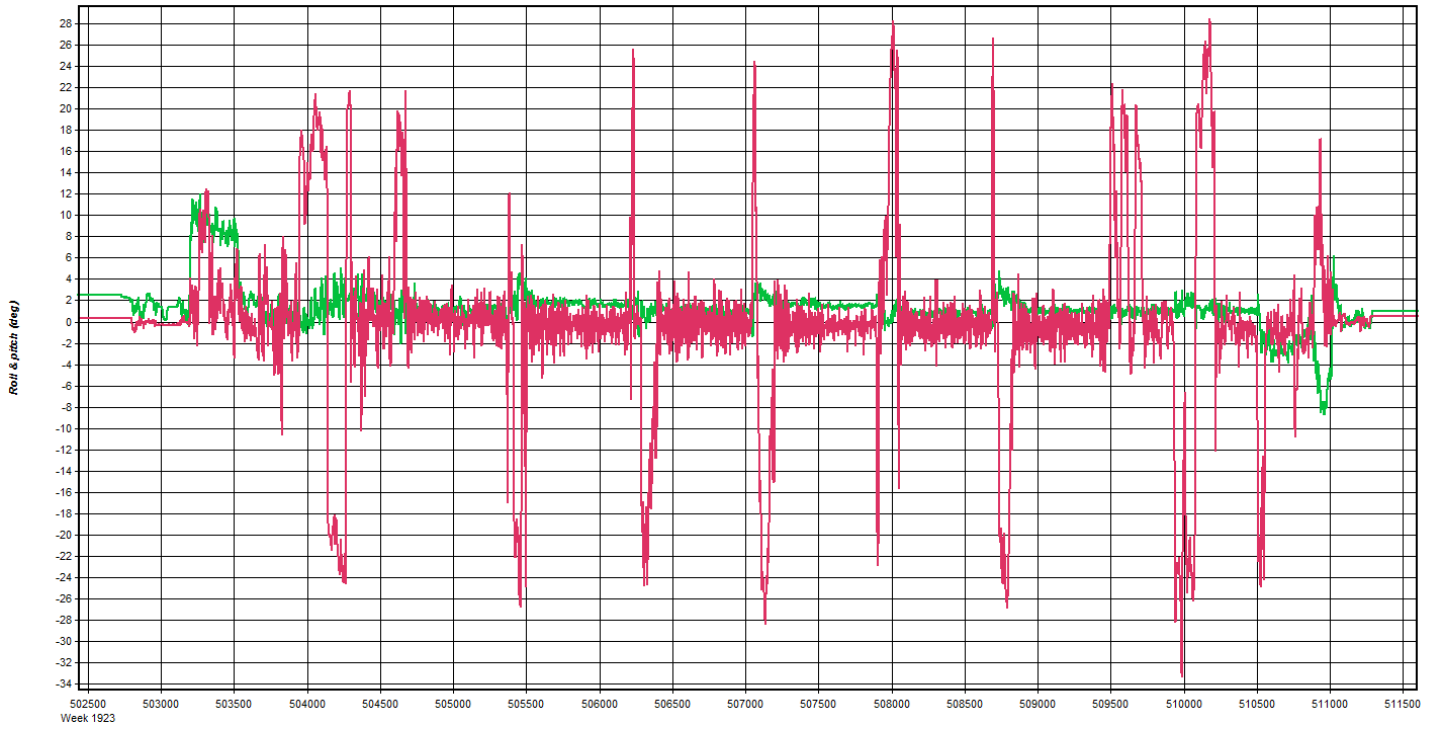

GPS Time (TOW, GMT zone)

— Roll — Pitch

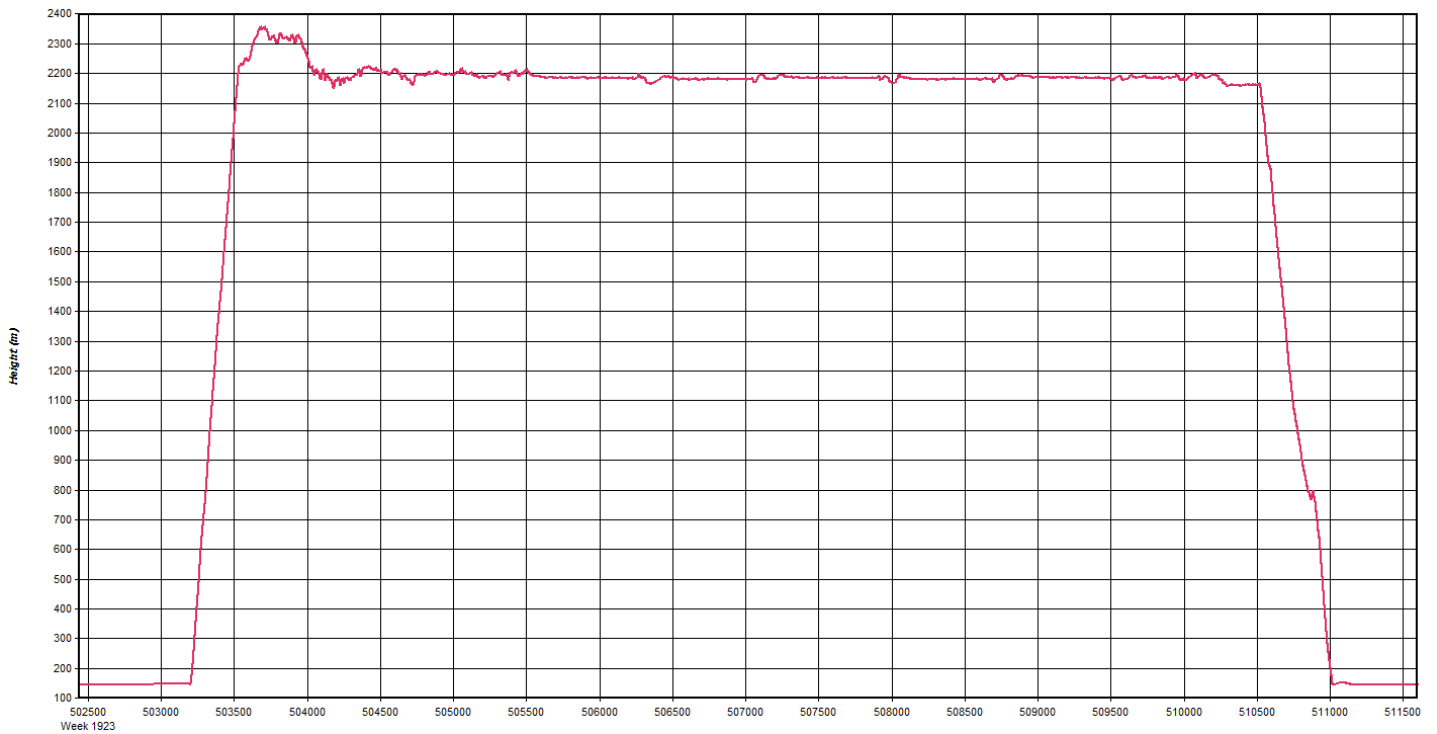

GPS Time (TOW, GMT zone)

— Height

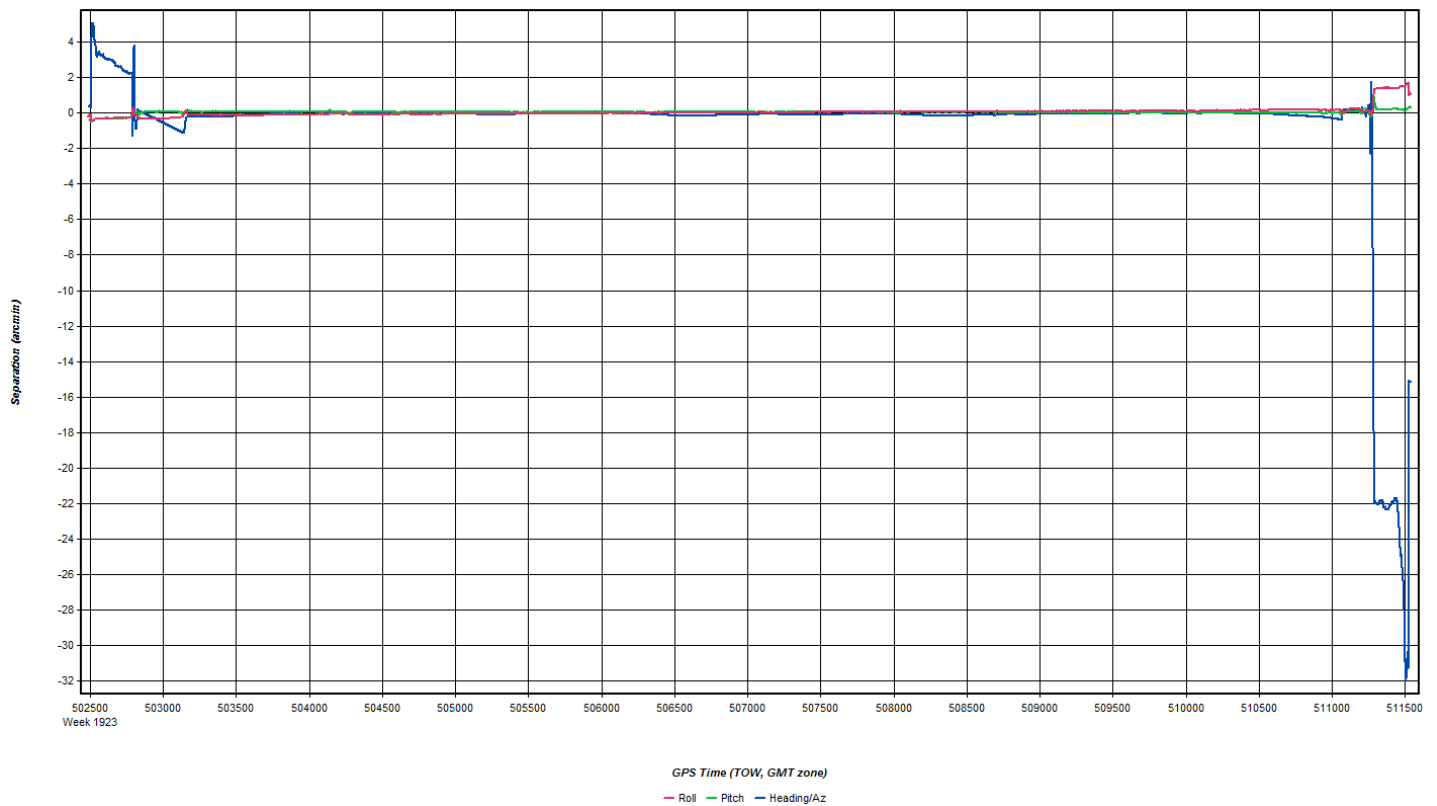
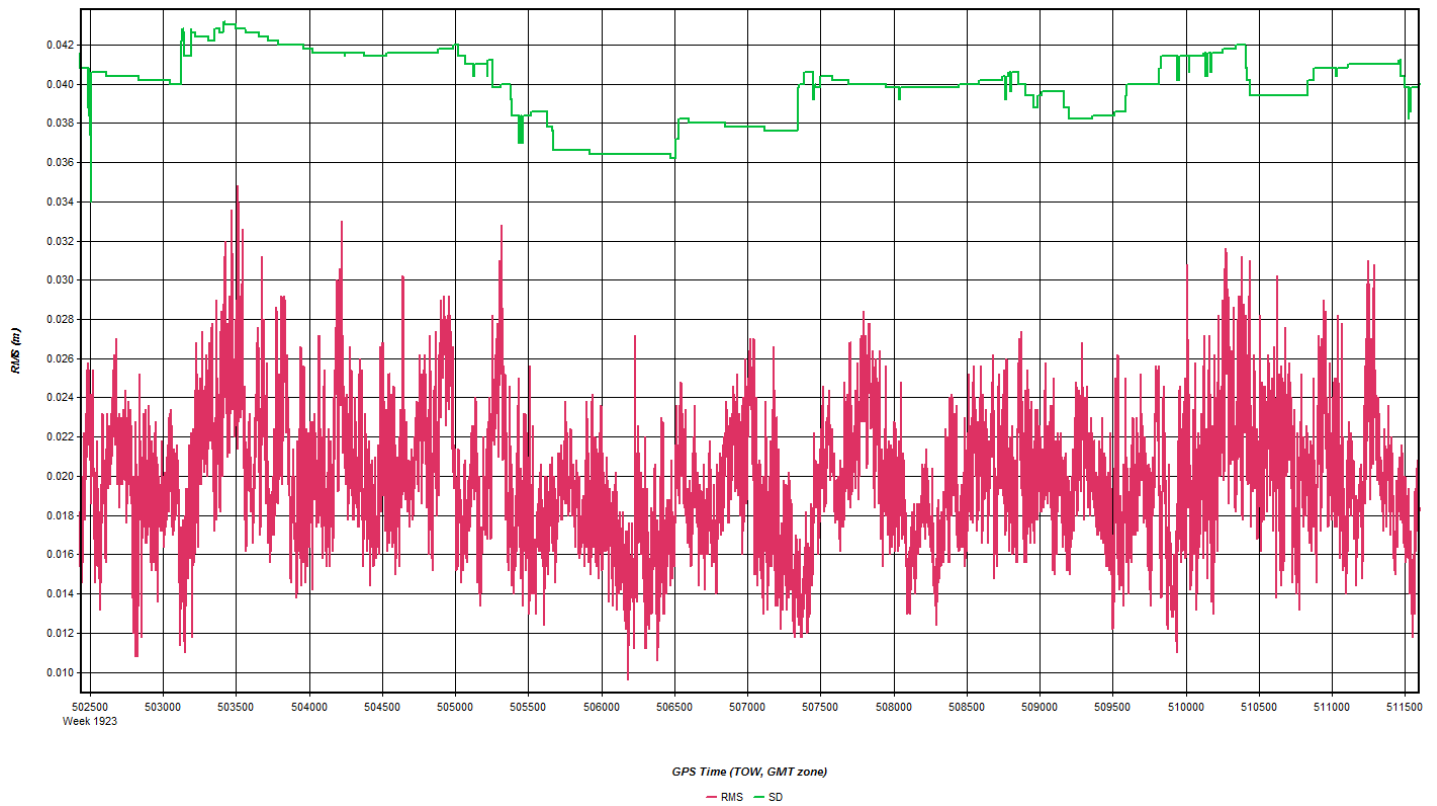

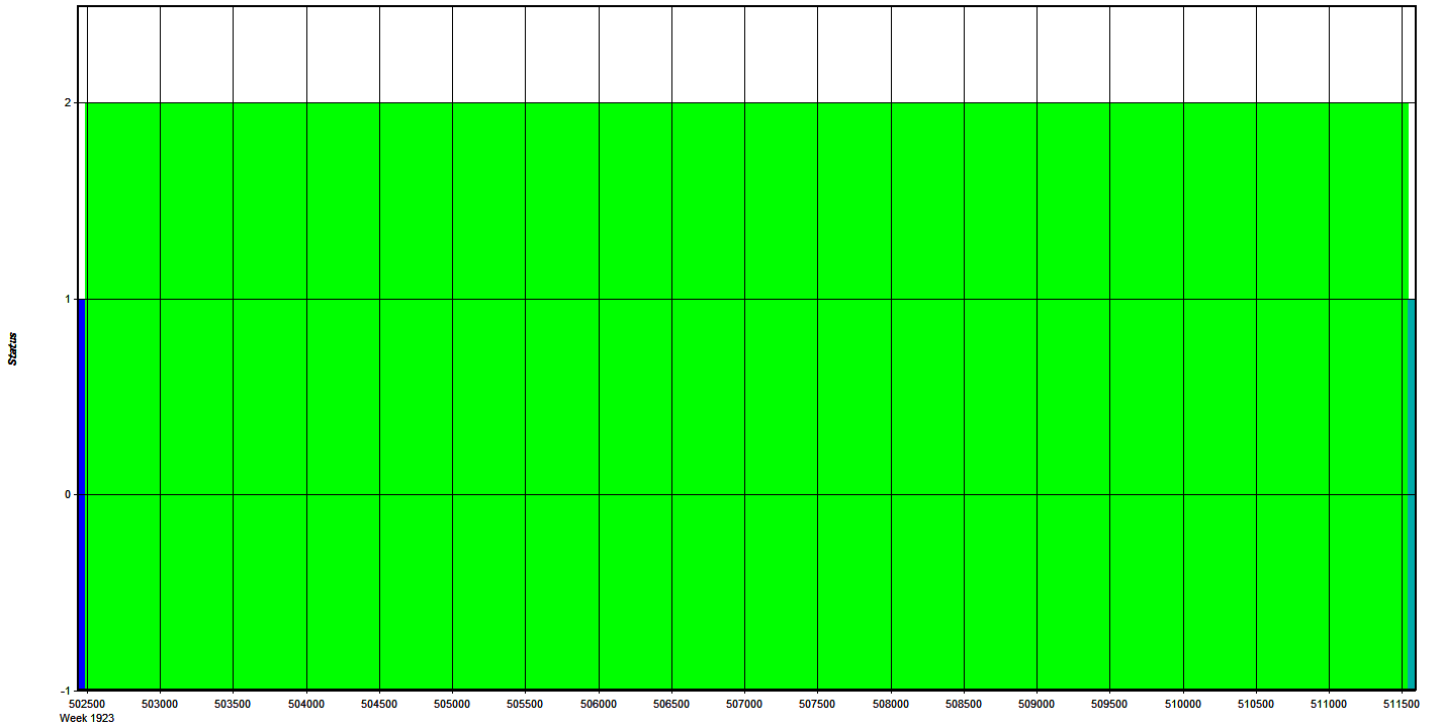

GPS Time (TOW, GMT zone)
 - Float - Forward Fixed - Reverse Fixed - Fixed (2 or more)

Coordinate/Antenna Settings

Master Remote

Base Station
 1: VTC1 Name: VTC1 Disabled
 File: E:\Proc\29178_CT_River\20161118_A_B_29178_SN7161_N22G

Coordinates
 Latitude: North 43 56 21.21809 Compute from PPP
 Longitude: West 72 36 12.56537 Enter Grid Values
 Ellipsoidal height: 405.144 m Enter MSL Height
 Datum: WGS84 Datum Options
 Select From Favorites Add To Favorites Use Average Position

Antenna Height
 From station file: TRM55971.00, NONE View STA File
 Antenna profile: TRM55971.00 Info
 Measured height: 0.000 m
 ARP to L1 offset: 0.067 m
 Applied height: 0.067 m
 Measured to
 ARP
 L1 Phase Centre
 Compute From Slant

OK Cancel

Coordinate/Antenna Settings

Master Remote

Base Station
2: VTOX Name: VTOX Disabled
File: E:\Proc\29178_CT_River\20161118_A_B_29178_SN7161_N22G

Coordinates
Latitude: North 44 00 28.16564 Compute from PPP
Longitude: West 72 06 51.60957 Enter Grid Values
Ellipsoidal height: 126.405 m Enter MSL Height
Datum: WGS84 Datum Options
Select From Favorites Add To Favorites Use Average Position

Antenna Height
From station file: TRM55971.00, NONE View STA File
Antenna profile: TRM55971.00 Info
Measured height: 0.000 m
ARP to L1 offset: 0.067 m
Applied height: 0.067 m
Measured to:
 ARP
 L1 Phase Centre
Compute From Slant

OK Cancel

Flight Log

Scanned by CamScanner

Project: CT River VT **Proj #:** 29178 **Flight Mgmt File:** 20161118_192950

Aircraft: N22GE **Begin Hobbs:** 8977.0 **End Hobbs:** 8977.2 **Total:** 2.2 **Pilot:** C. Christophy **Co-Pilot:** — **Tech:** JSW99

Dep Apt: KLEB **Dep Time (Lcl):** 1443 **Arr Time (Local):** 1745 **Arr Apt:** KLEB **Alt Time (Local):** 1745 **Tot Time Aloft:** 2.3

CORS: \odot VIN **Sta 1:** VTCL-1957 **Sta 2:** — **Flyovers (Y/N):** Y/N **IF Y, times: Sta 1:** — **IF Y, times: Sta 2:** —

GPS Unit: Y/N **Sta 1:** 2144 **Sta 2:** — **Flyovers (Y/N):** Y/N **IF Y, times: Sta 1:** — **IF Y, times: Sta 2:** —

Gd Temp beg: 10 °C **End:** — °C **OAT beg:** 8 °C **End:** 8 °C **Altimeter begin:** 3006 **end:** 3006

Type	Serial #	Alt AGL	Alt ANSL	Pulses In Air	Max Gdspd	Power	Avg Pt Spacing	PPSM	Example Number	
									End GB	Tot GB
LIDAR	A1570	2161	—	—	—	—	—	—	997	16
FOV	40	53	—	—	—	100%	—	—	474	23

Line #	Hdg	Start (UTC)	End (UTC)	Gd Spd	POOP/Sec	GPS Altitude	Crab	Turb (0, 5, 1)	Notes
2037	197	1943	2005	150	1.2/17	7108	0	0	LEB → VTCL (1957) Fig 8's (2001-2005)
2042	17	2025	2036	184	1.1/17	7214	0	0	of Reflight Good*
2043	197	2040	2050	141	1.5/15	7185	0	0	"*
2044	17	2054	2104	143	1.3/16	7175	0	0	"*
2045	197	2108	2117	158	1.3/17	7210	0	0	
2046	17	2121	2130	143	1.1/18	7204	0	0	upplanned
Xtie	289	2135	2138	154	1.1/17	7187	0	0	Site → Fig 8's
		2138-2143							Fig 8's → VTCL
		2143-2146							VTCL-LEB
		2146-2157							

118 B **Hobbs** = 2.2 **118 Total** **Hobbs** = 5.9
Online = 1.4 **Online** = 4.4
MOB = 0.8 **MOB** = 1.5

Total Proj Lines: — **Lines Flow:** — **Lines Remain:** — **Online Time:** 1.4 **Mob Time:** 0.8 **Notes:** —

Nov 19, 2016-A (N22GE, SN7161)

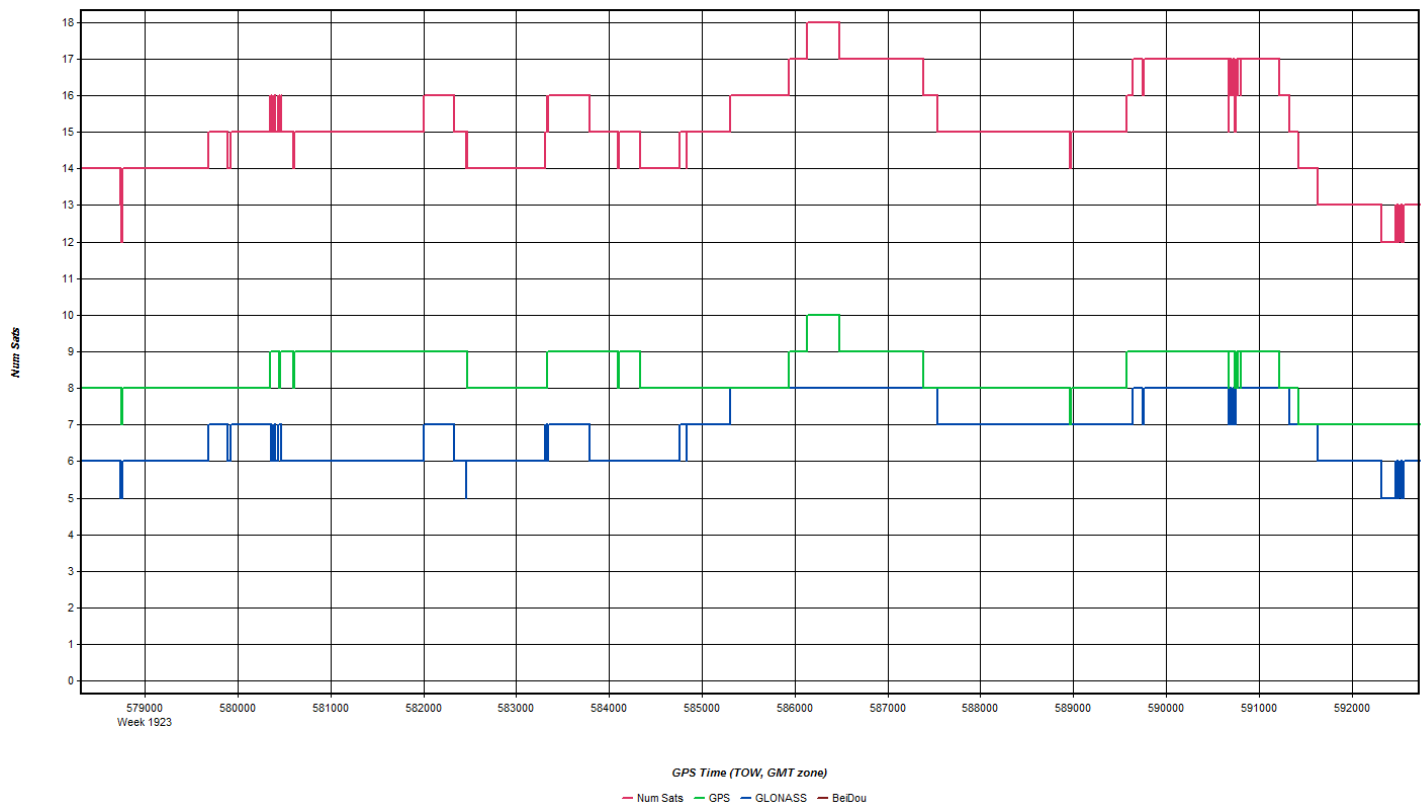
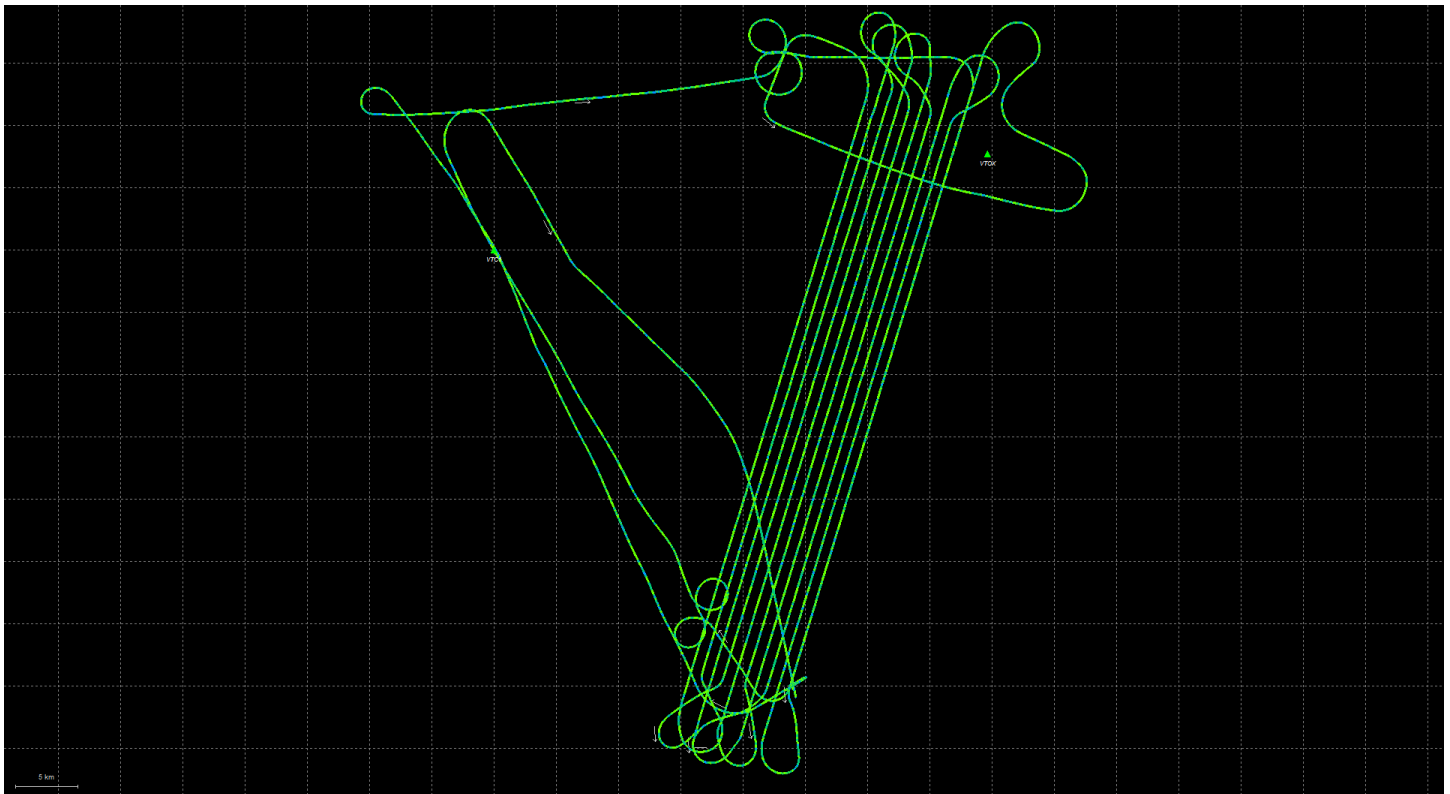

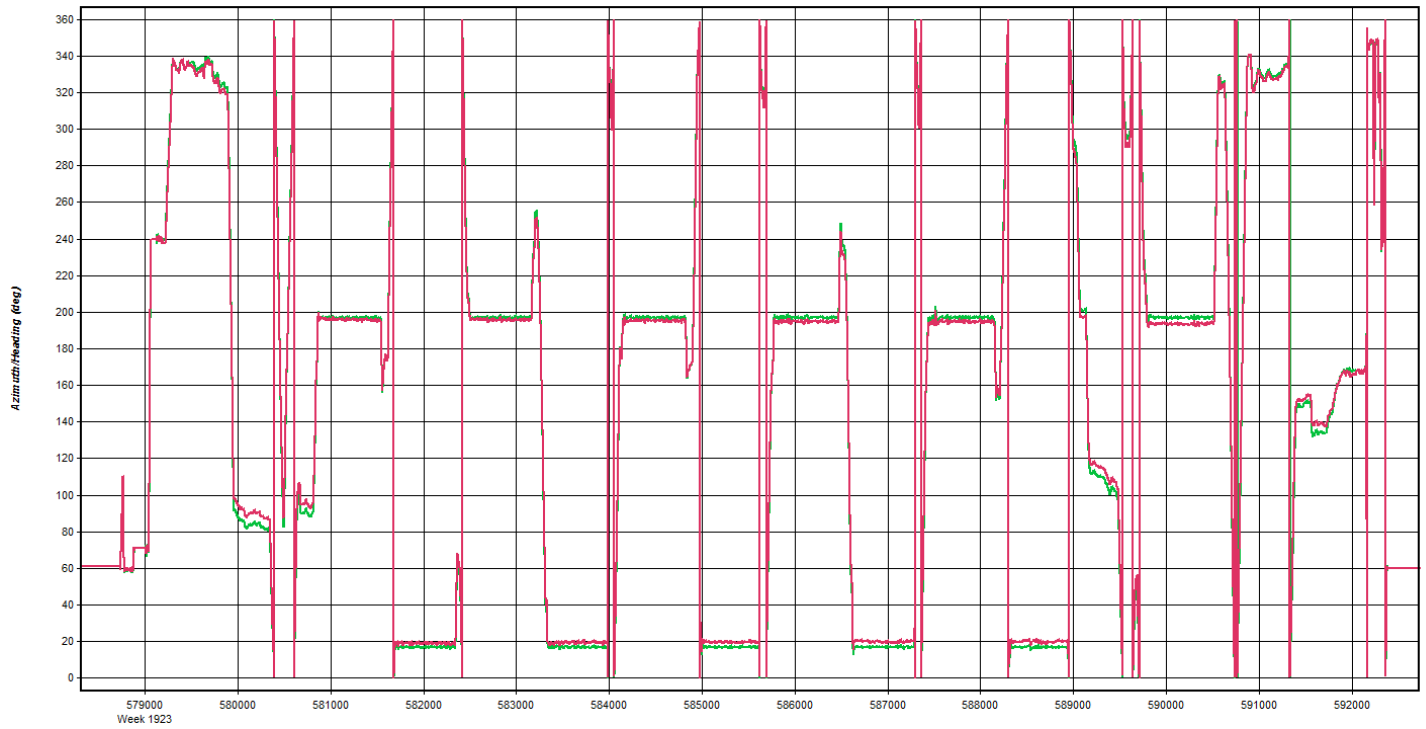
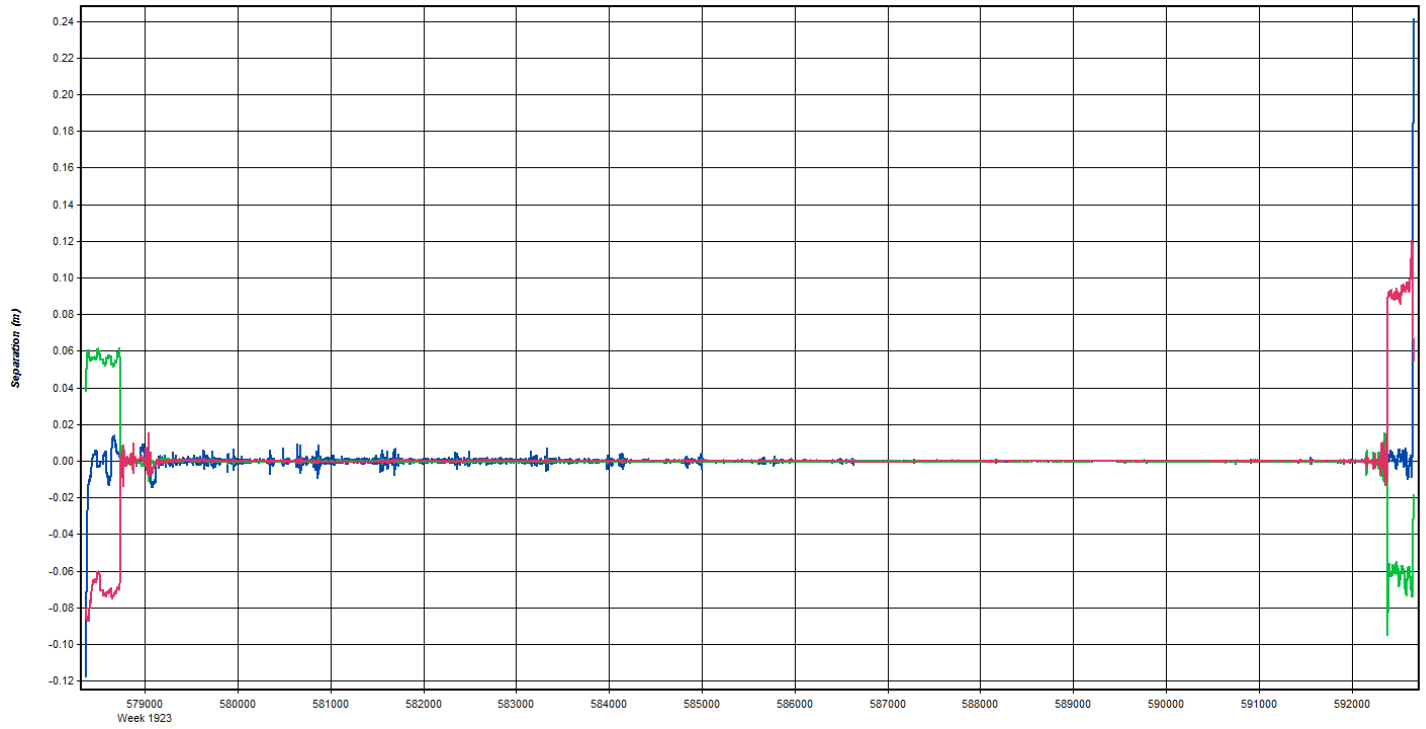

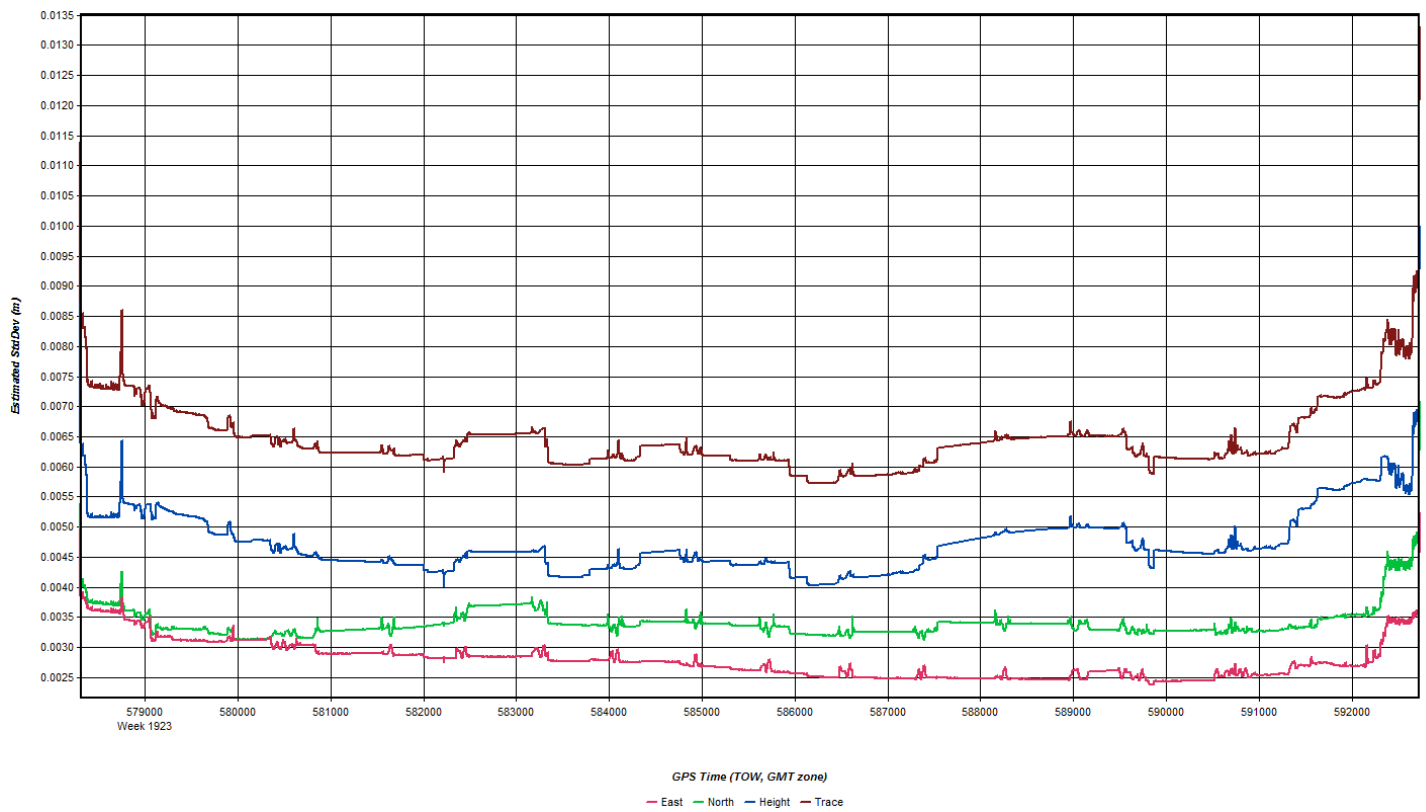
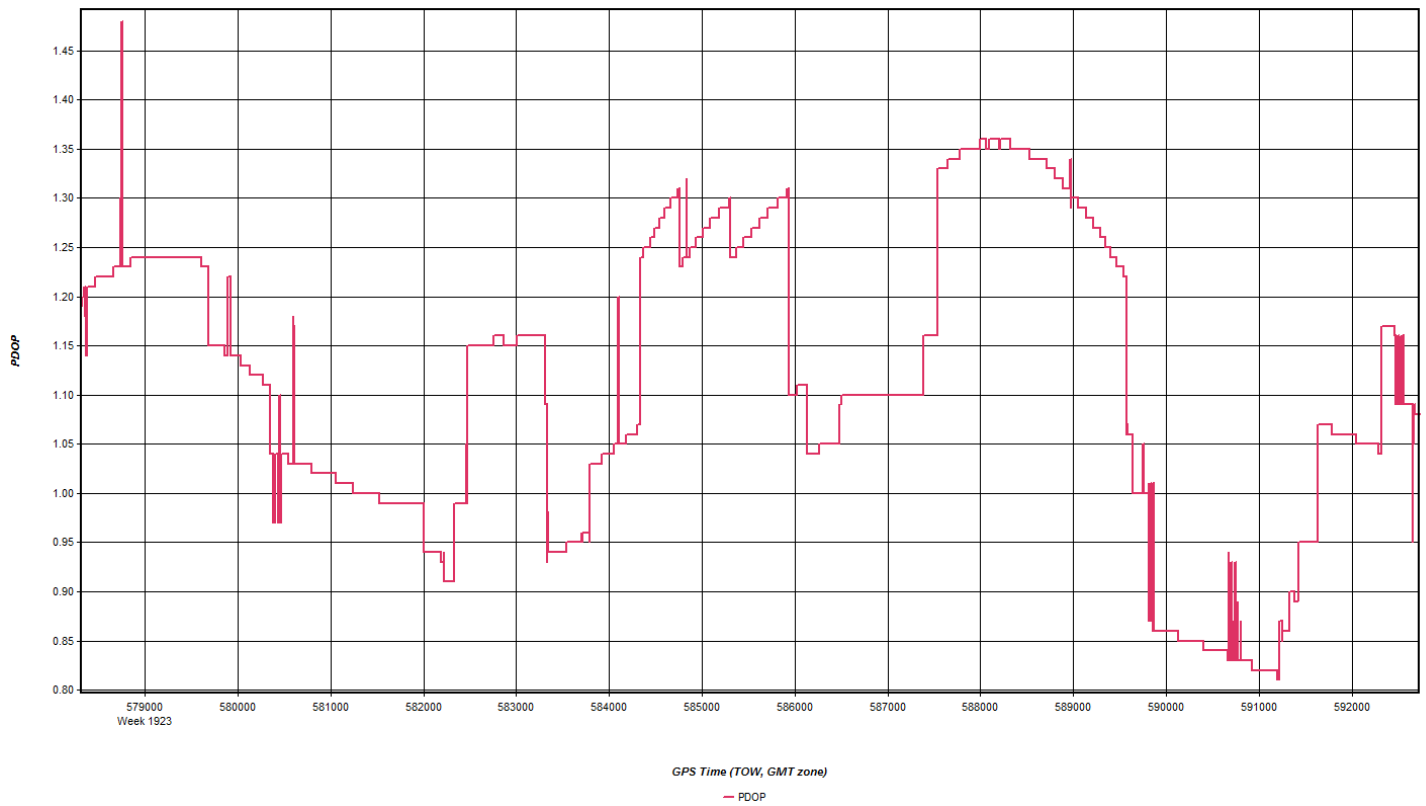

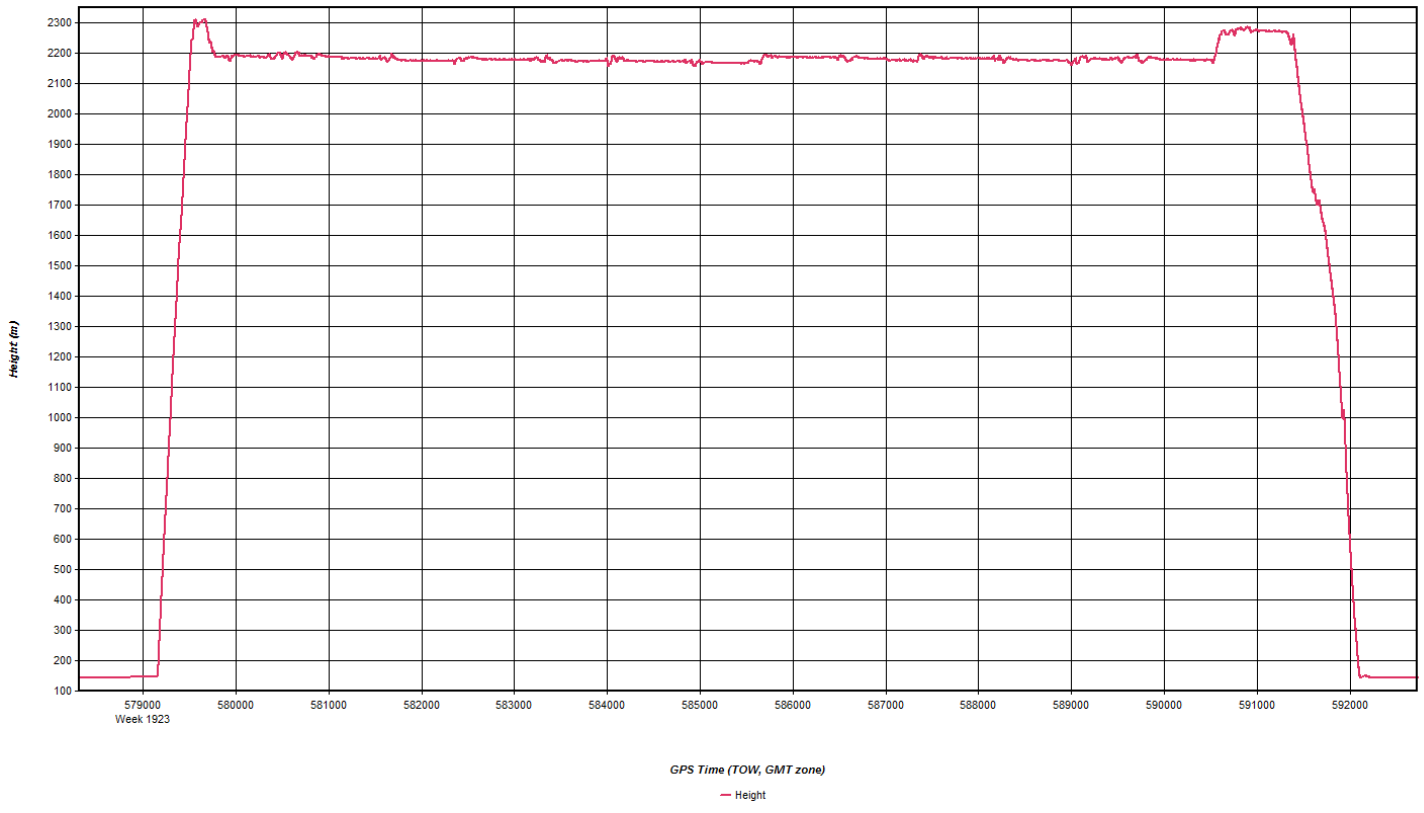
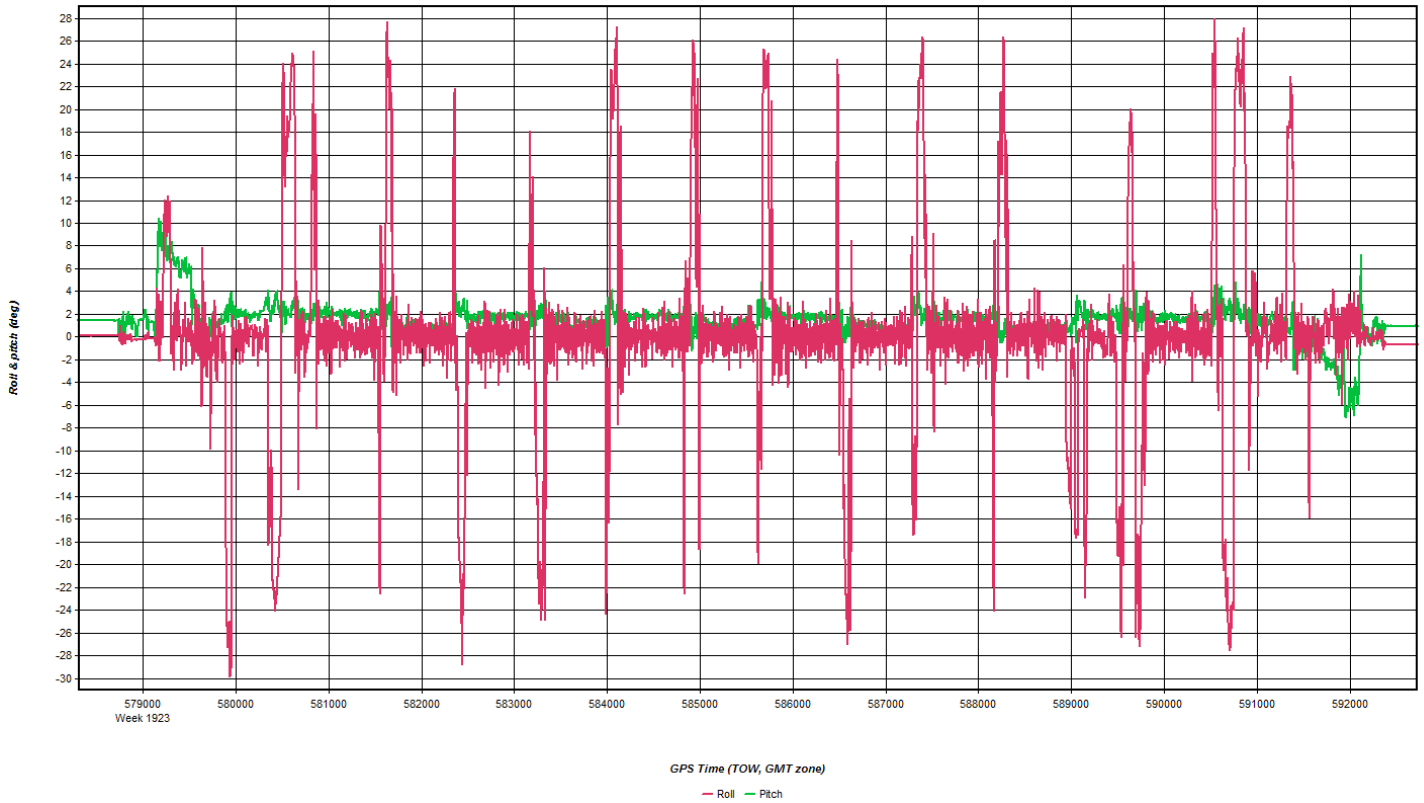

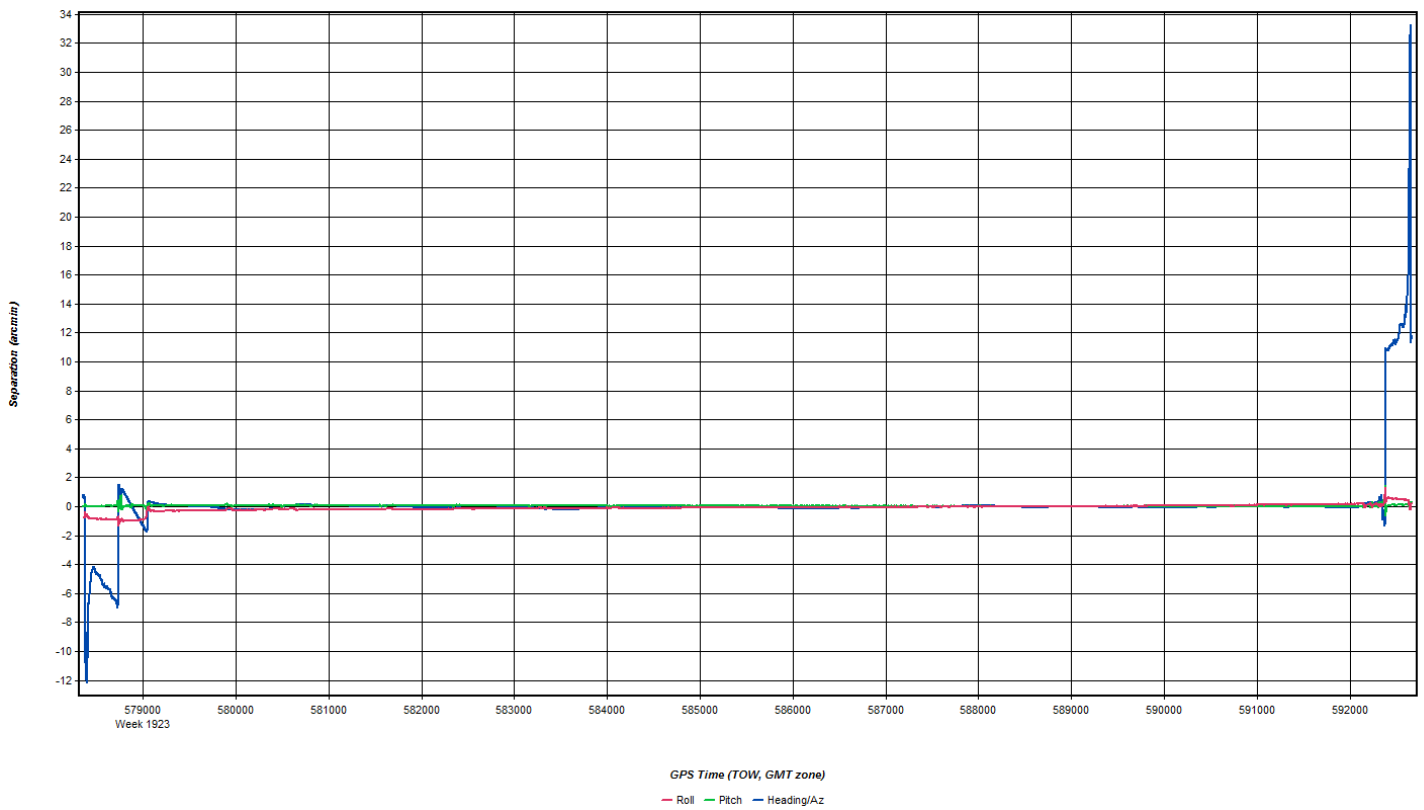
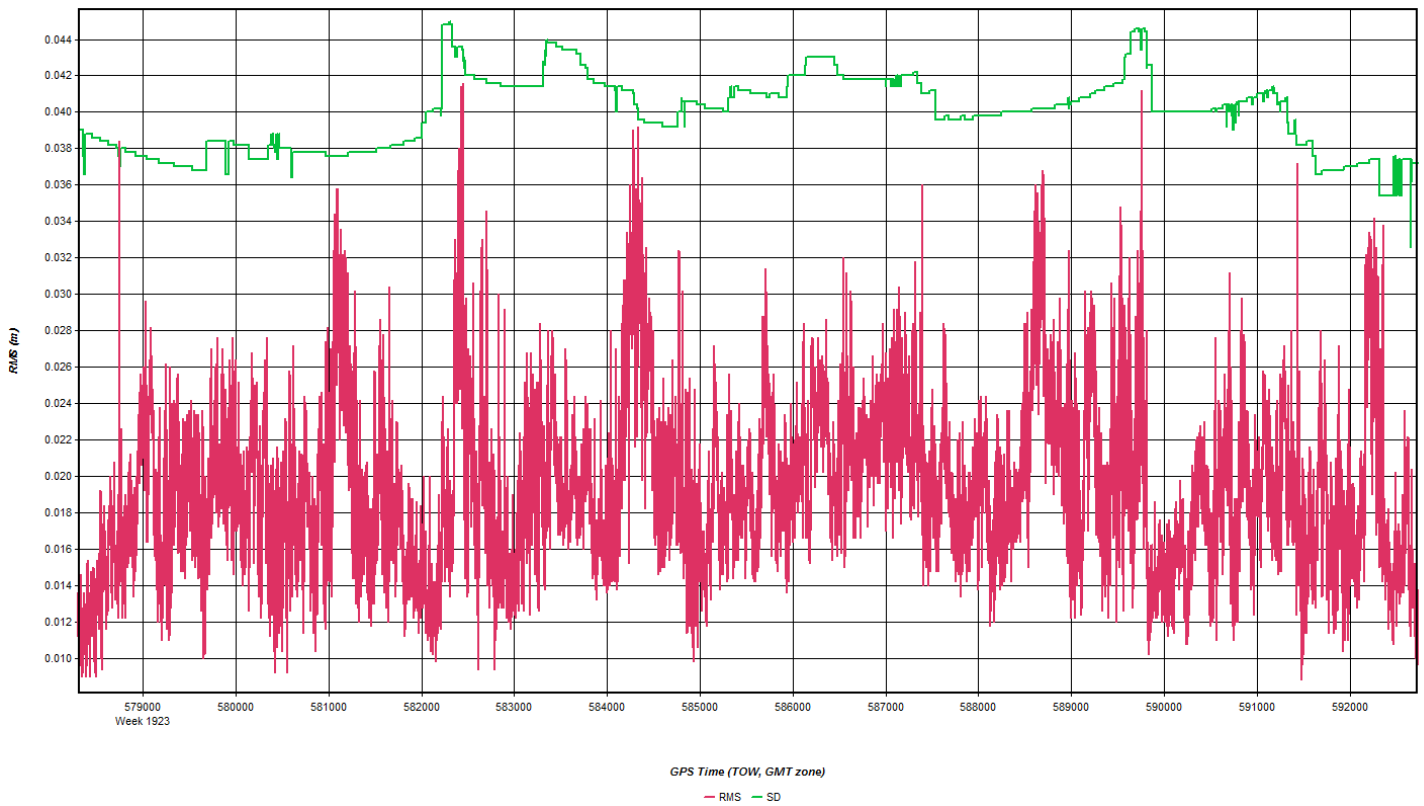

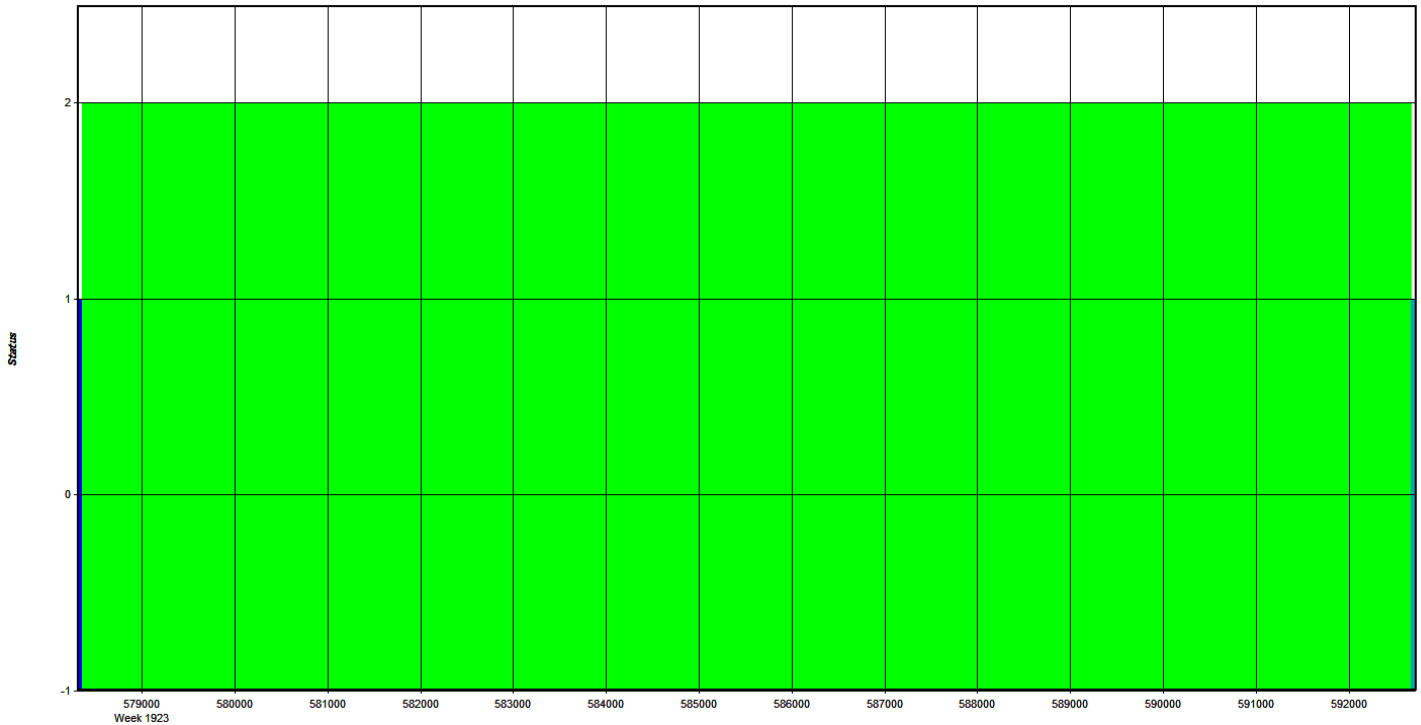

GPS Time (TOW, GMT zone)
 - Float - Forward Fixed - Reverse Fixed - Fixed (2 or more)

Coordinate/Antenna Settings

Master Remote

Base Station
 1: VTC1 Name: VTC1 Disabled
 File: E:\Proc\29178_CT_River\20161119_A_29178_SN7161_N22GE\

Coordinates
 Latitude: North 43 56 21.21809 Compute from PPP
 Longitude: West 72 36 12.56537 Enter Grid Values
 Ellipsoidal height: 405.144 m Enter MSL Height
 Datum: WGS84 Datum Options
 Select From Favorites Add To Favorites Use Average Position

Antenna Height
 From station file: TRM55971.00, NONE View STA File
 Antenna profile: TRM55971.00 Info
 Measured height: 0.000 m
 ARP to L1 offset: 0.067 m
 Applied height: 0.067 m
 Measured to:
 ARP
 L1 Phase Centre
 Compute From Slant

OK Cancel

Coordinate/Antenna Settings

Master Remote

Base Station
2: VTOX Name: VTOX Disabled
File: E:\Proc\29178_CT_River\20161119_A_29178_SN7161_N22GE\

Coordinates
Latitude: North 44 00 28.16564 Compute from PPP
Longitude: West 72 06 51.60957 Enter Grid Values
Ellipsoidal height: 126.405 m Enter MSL Height
Datum: WGS84 Datum Options
Select From Favorites Add To Favorites Use Average Position

Antenna Height
From station file: TRM55971.00, NONE View STA File
Antenna profile: TRM55971.00 Info
Measured height: 0.000 m
ARP to L1 offset: 0.067 m
Applied height: 0.067 m
Measured to:
 ARP
 L1 Phase Centre
Compute From Slant

OK Cancel

Flight Log

Scanned by CamScanner

11-19-16 -A -29178

Airborne LIDAR Data Collection Log Sheet :: Quantum Spatial, Inc
(email log daily to flight_log_distribution_list@quantumspatial.com)

Date: 11-19-16 A
Lift: (A) B C D E Pg. 1 of 1

Project: CT RIVER VT Proj #: 29178 Flight Mgmt File: 20161119-163331
Aircraft: N22GE Begin Hobbs: 8979.2 End Hobbs: 8982.8 Total: 3.6 Pilot: Christopher Co-Pilot: Tech: JSwan
Dep Apt: KLEB Dep Time (Local): 1649 (Z): 15 Air Apt: KLEB Arr Time (Local): 1528 (Z): 15 Tot Time Aloft: 3.7
COORS: (Y) N Sta 1: VTCL1-170.3 Sta 2: Flyovers: (Y) N IF Y, times: Sta1) (Z) N IF Y, times: Sta2)
GPS Unit: Y I N Sta 1: 2012 Sta 2: Flyovers: Y I N IF Y, times: Sta1) (Z) N IF Y, times: Sta2)

Gd Temp beg: °C End: °C OAT beg: +7 °C End: +6 °C Altimeter begin: 2993 end: 2975
Storage Name: 473
End CB: 434
Tot CB: 39

LIDAR	Type	Serial #	FOV	Alt AGL	Alt ANSL	Alt Terr Ht	Max Cdspd	Avg Pt Spacing	Pulse Rate	Power	PPSM
			7161	40	260	KHz	MPIA	Y I N			100%

Line #	Hdg	Start (UTC)	End (UTC)	GSpd	Alt	Alt ANSL	Alt Terr Ht	Max Cdspd	Avg Pt Spacing	Pulse Rate	Power	PPSM	Storage Name
*2056	197	1721	1731	140	1.1/17	7170	0	0	0	0	0	0	473
2055	17	1735	1745	153	1.1/17	7172	0	0	0	0	0	0	434
2054	197	1749	1758	145	1.2/16	7175	0	0	0	0	0	0	39
2053	17	1803	1812	160	1.2/16	7157	0	0	0	0	0	0	
2052	197	1816	1826	158	1.1/17	7100	0	0	0	0	0	0	
2051	17	1830	1840	148	1.0/18	7117	0	0	0	0	0	0	
2050	197	1843	1853	137	1.1/18	7164	0	0	0	0	0	0	
2049	17	1857	1907	151	1.1/18	7142	0	0	0	0	0	0	
2048	197	1911	1920	140	1.2/17	7159	0	0	0	0	0	0	
2047	17	1925	1935	156	1.4/16	7165	0	0	0	0	0	0	
Xtie E	1940	1944	160	1.3/17	7161	0	0	0	0	0	0	0	
*2056	197	1951	2001	153	1.3/17	7177	0	0	0	0	0	0	
		2001	2007										
		2007	2012										
		2012	2021										

LEB → VTCL1 (1703) - Fig 8's (1711-1718)
cloud fog 18-13 mi FSE Reflown below

unplanned Reflown cloud free
Site - Fig 8's (2011-2007)
Fig 8's → VTCL1 (2012)
VTCL1 → LEB

Hobbs = 3.6
ANIME = 2.7
mob = 1.0

Project Complete

Total Proj Lines: Lines Flow: Lines Remain: Online Time: 2.6 Mob Time: 1.0 Notes:

Nov 19, 2016-A (N73TM, SN7178)

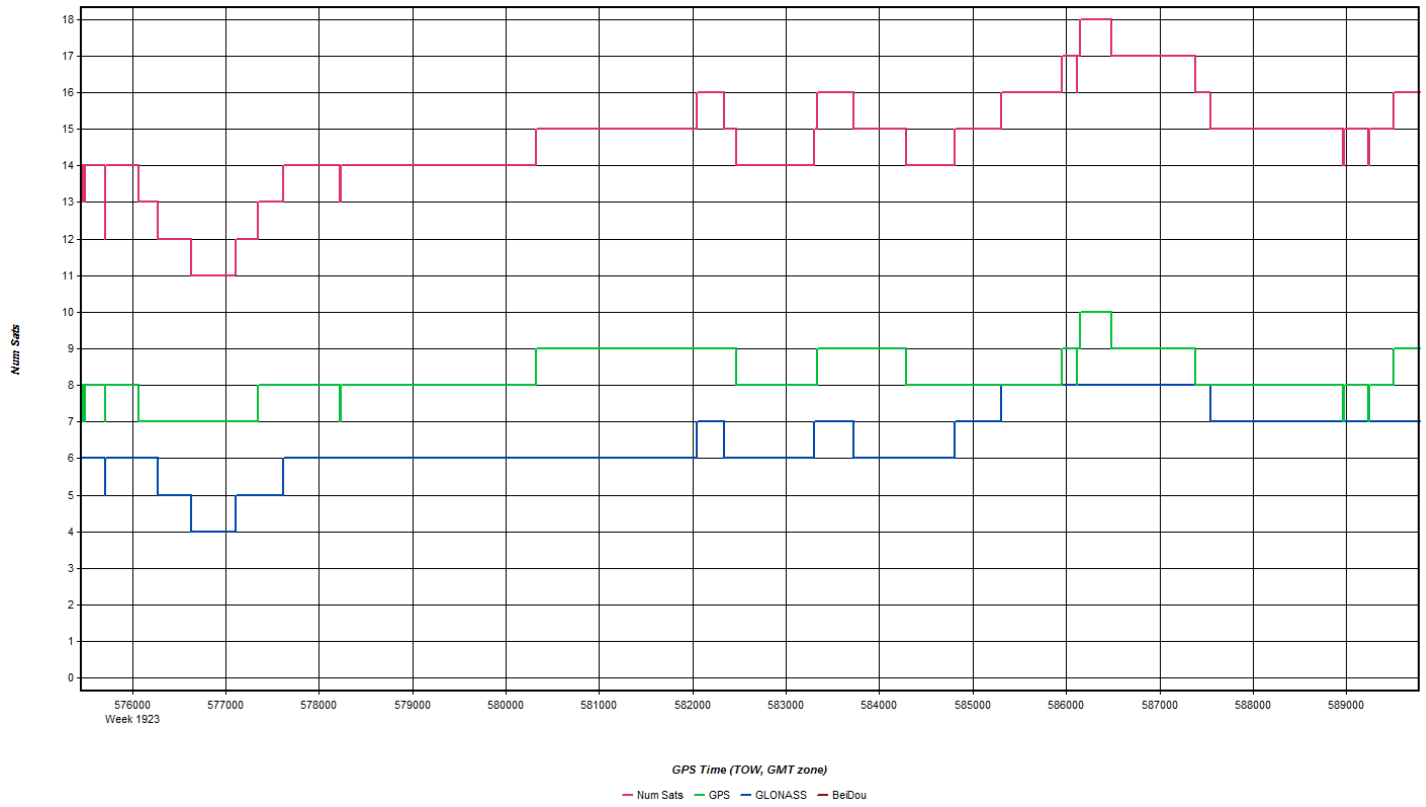
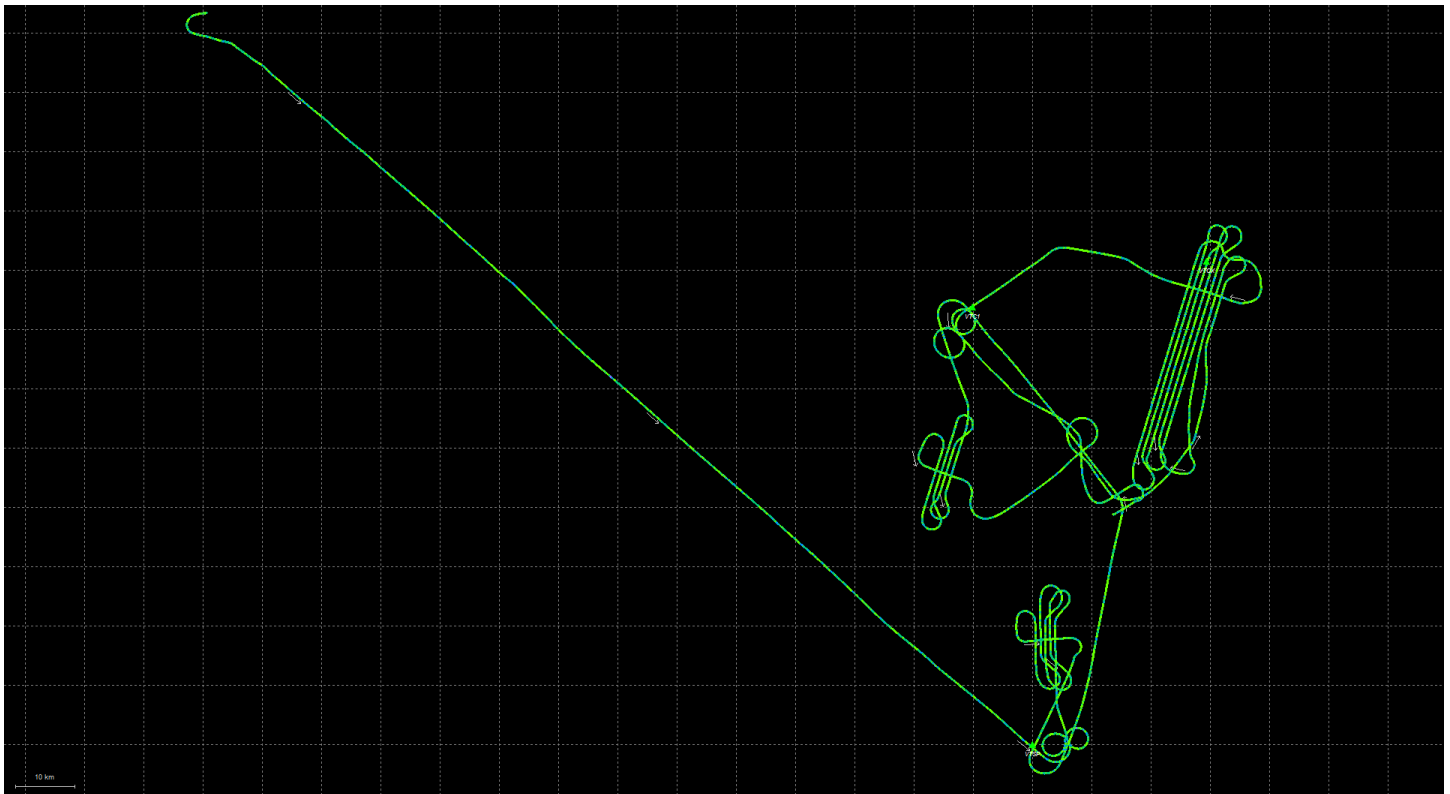

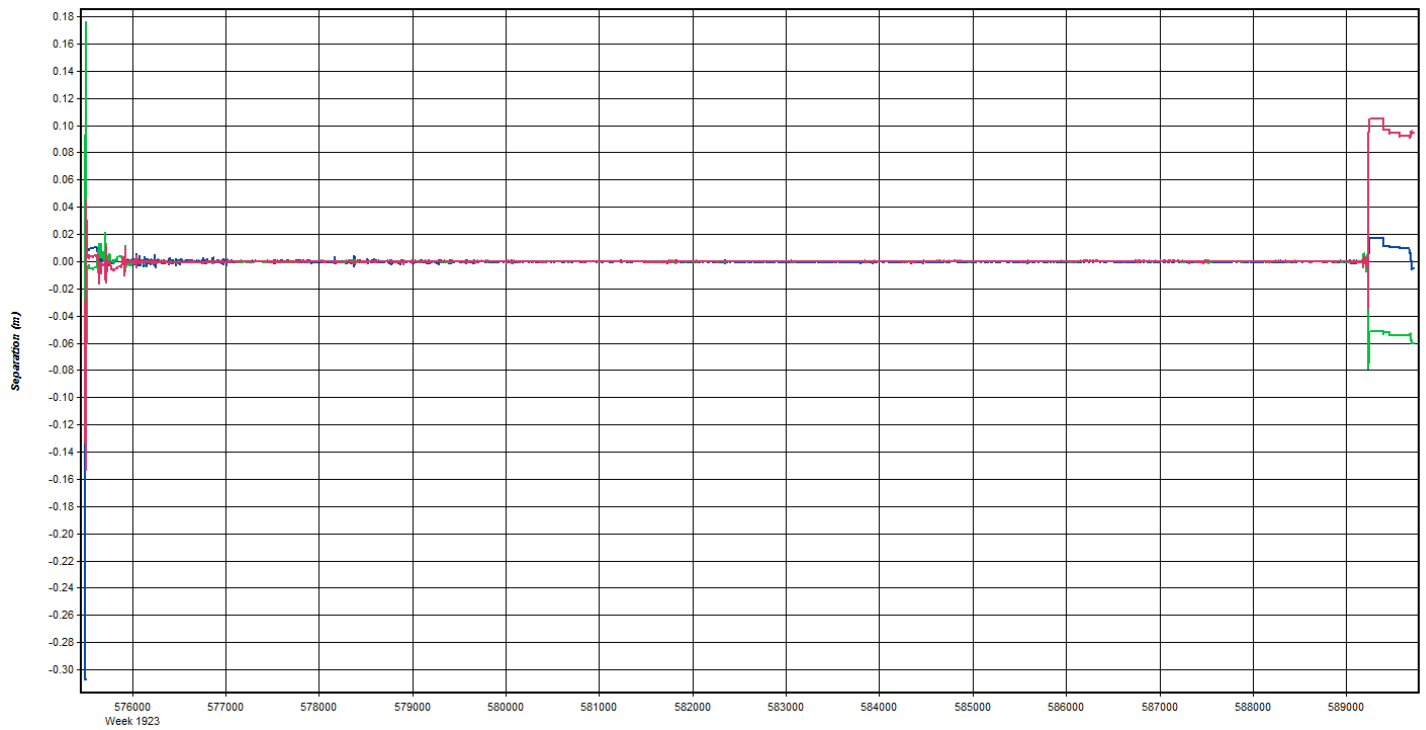

GPS Time (TOW, GMT zone)

— East — North — Up

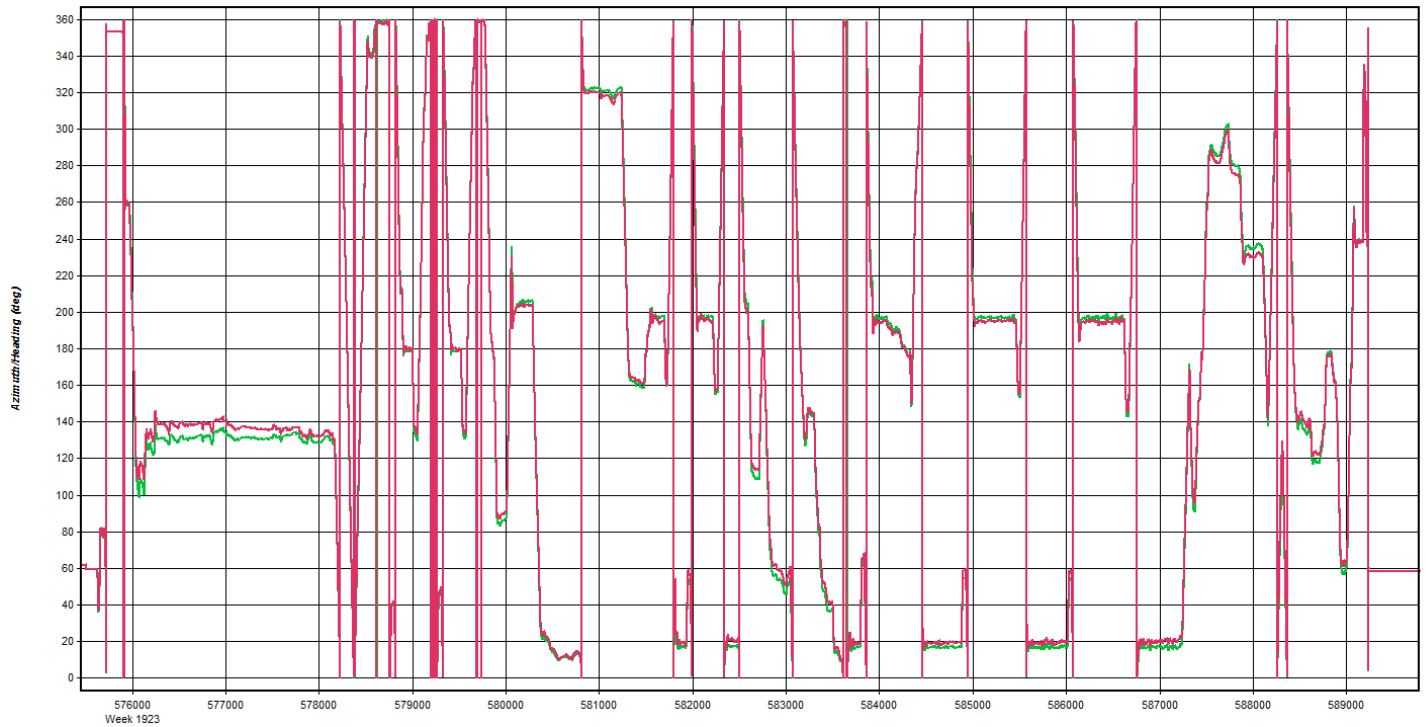

GPS Time (TOW, GMT zone)

— Heading/Azimuth — GPS-COG

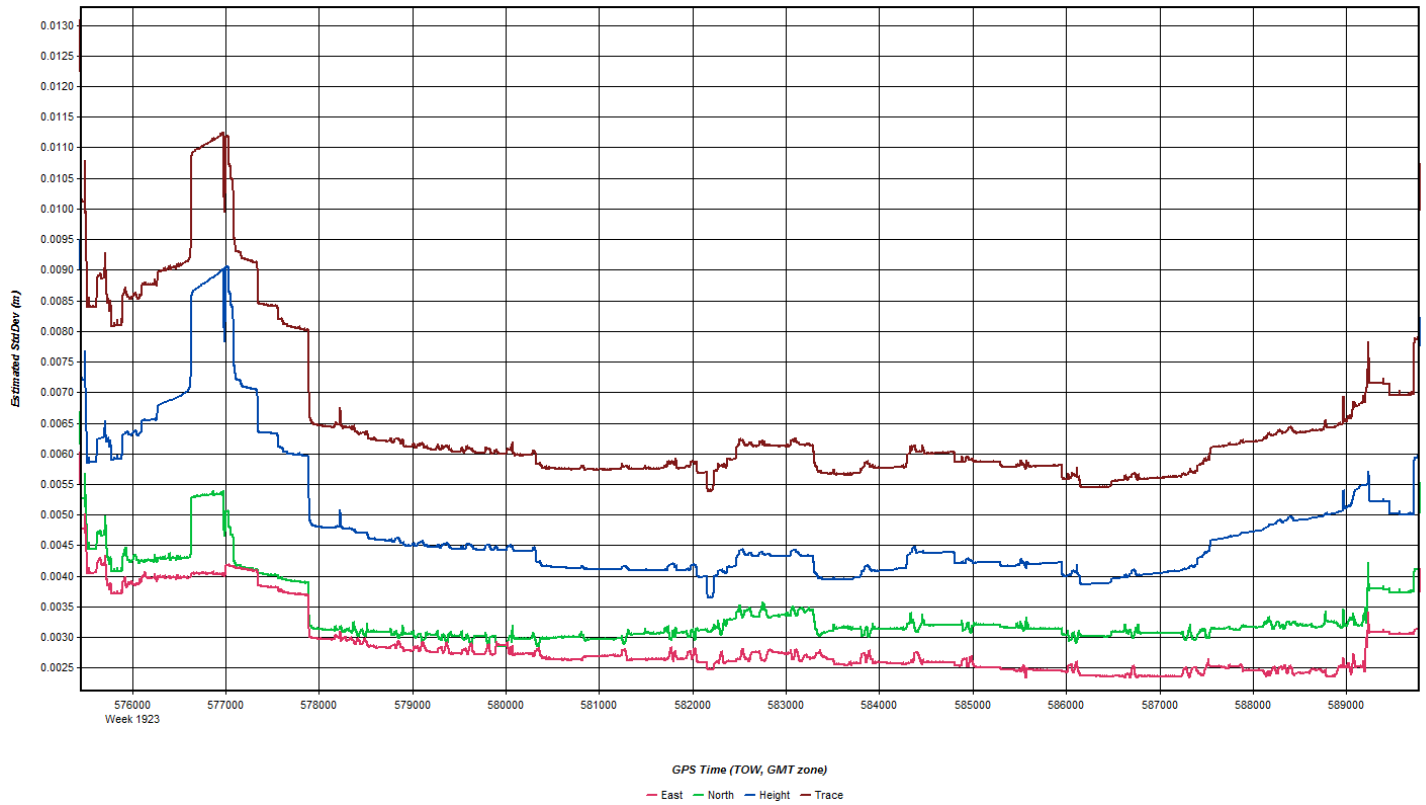
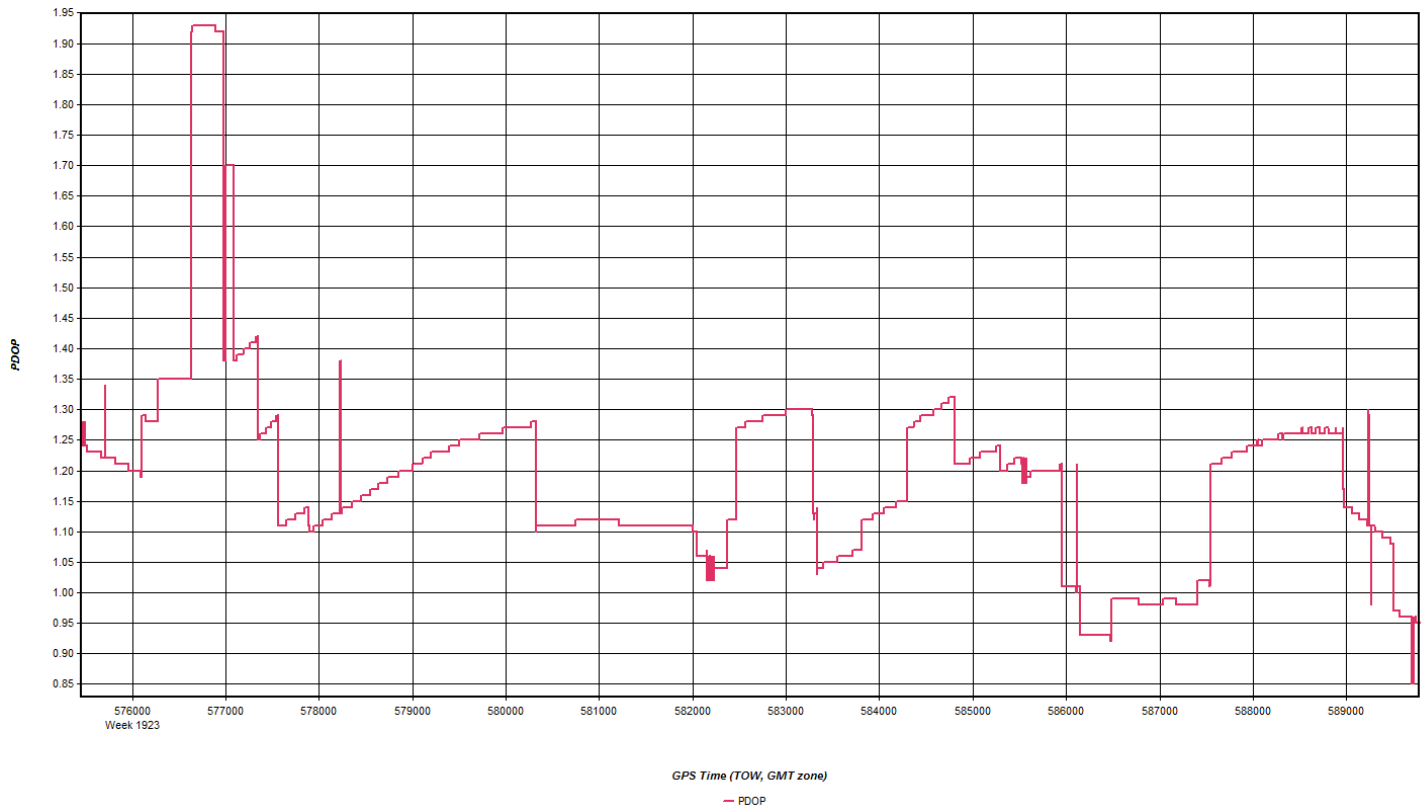

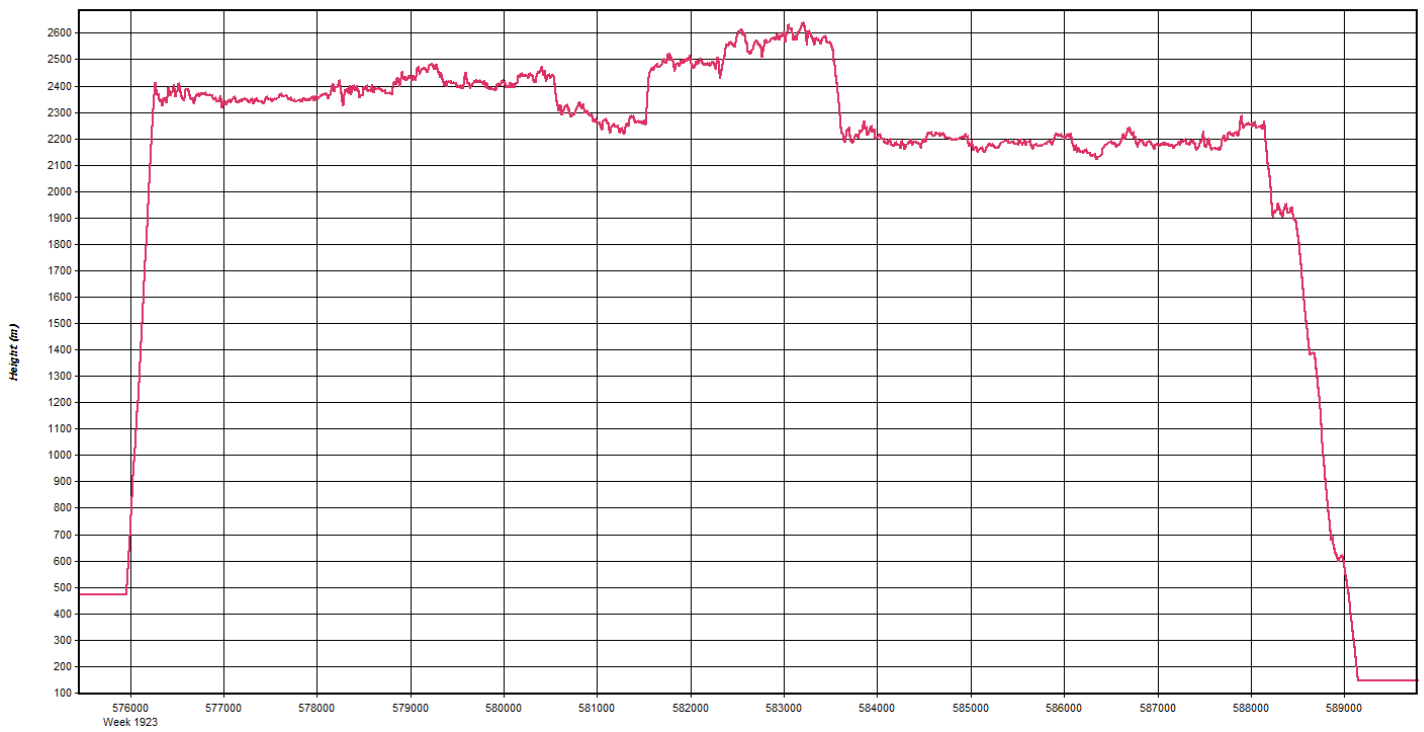
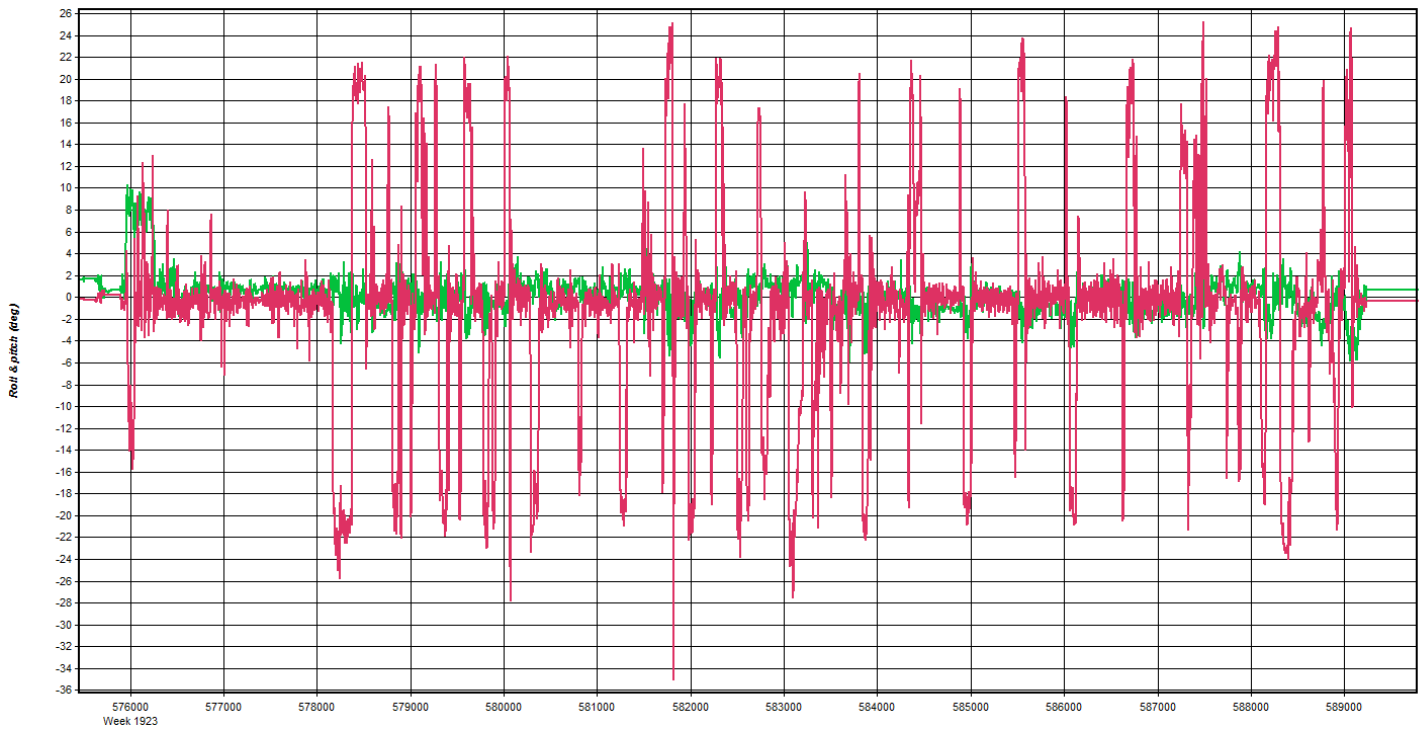

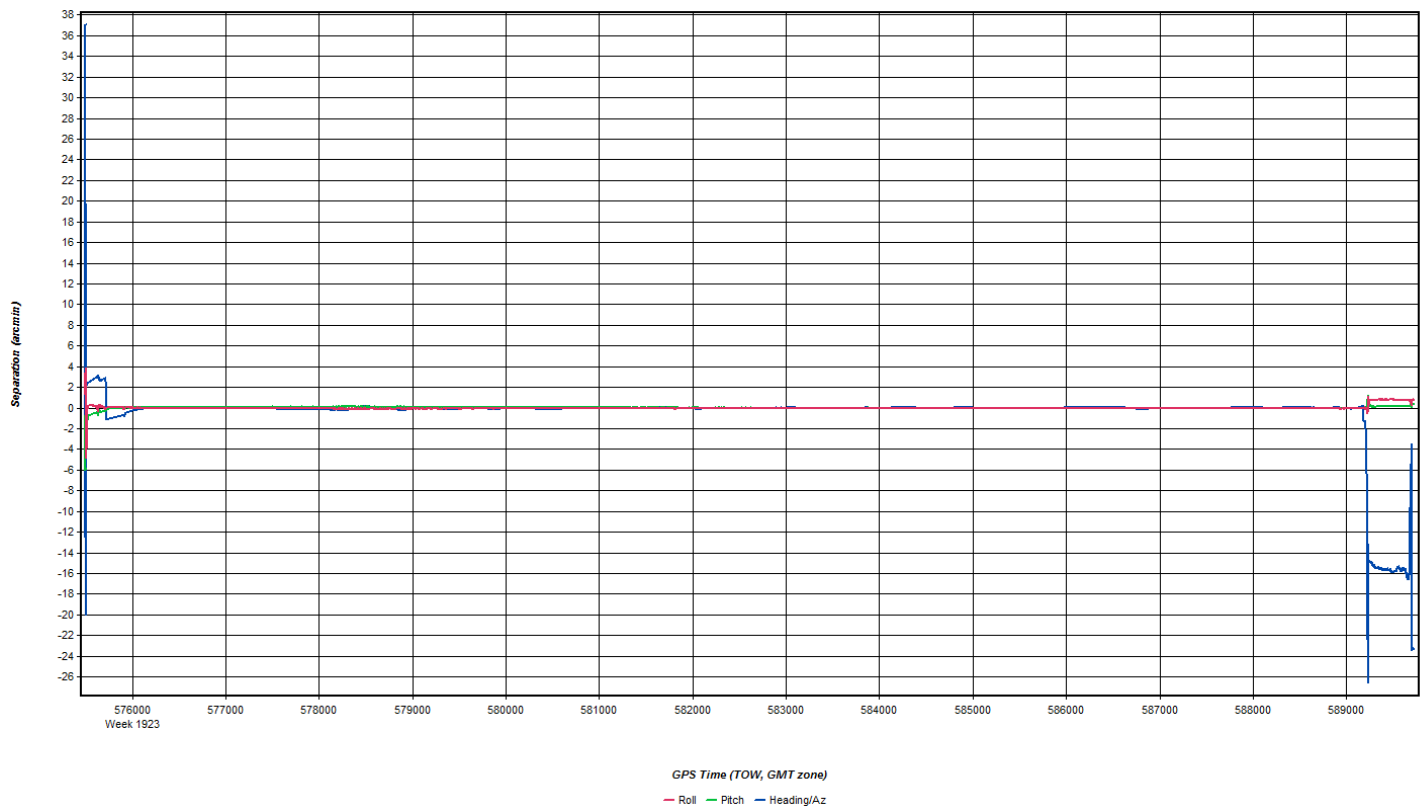
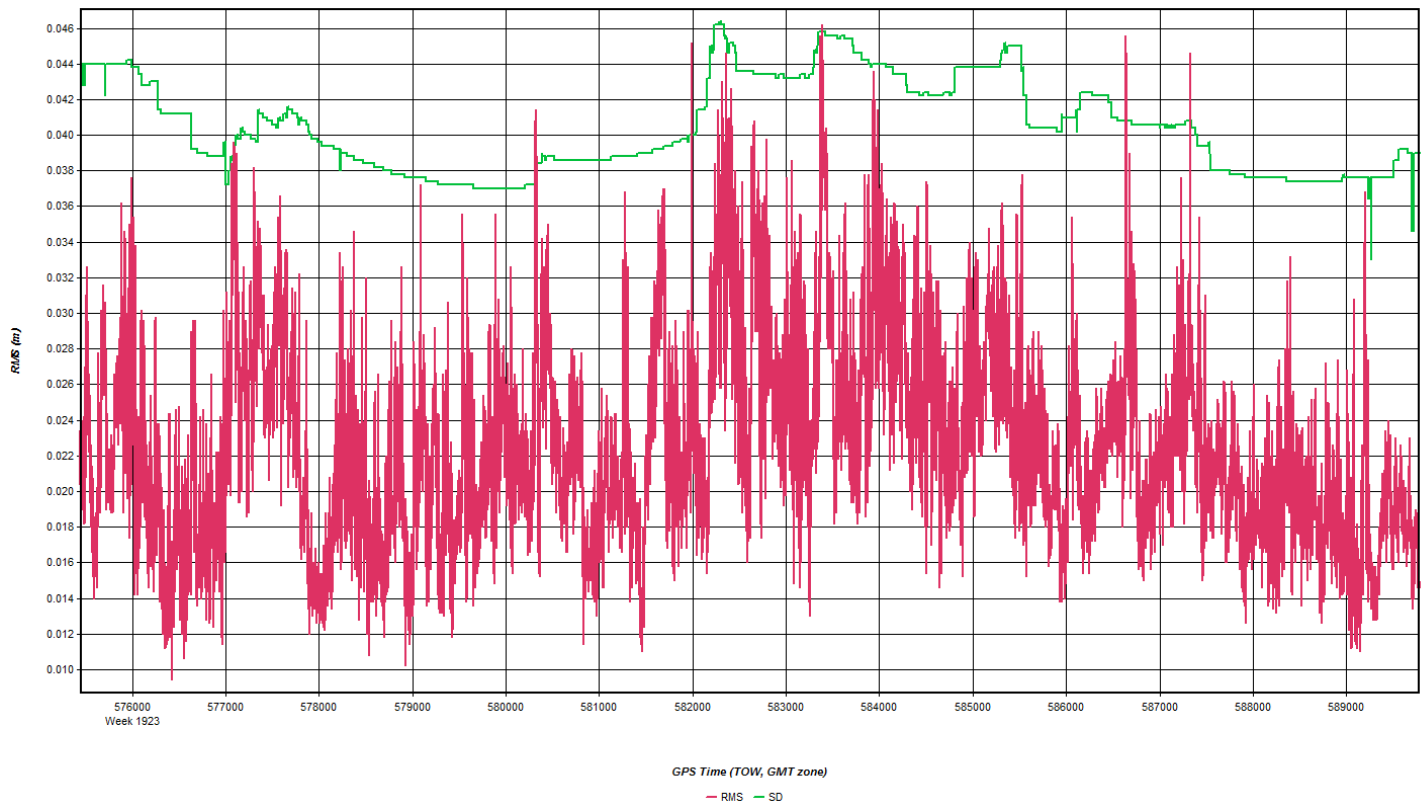

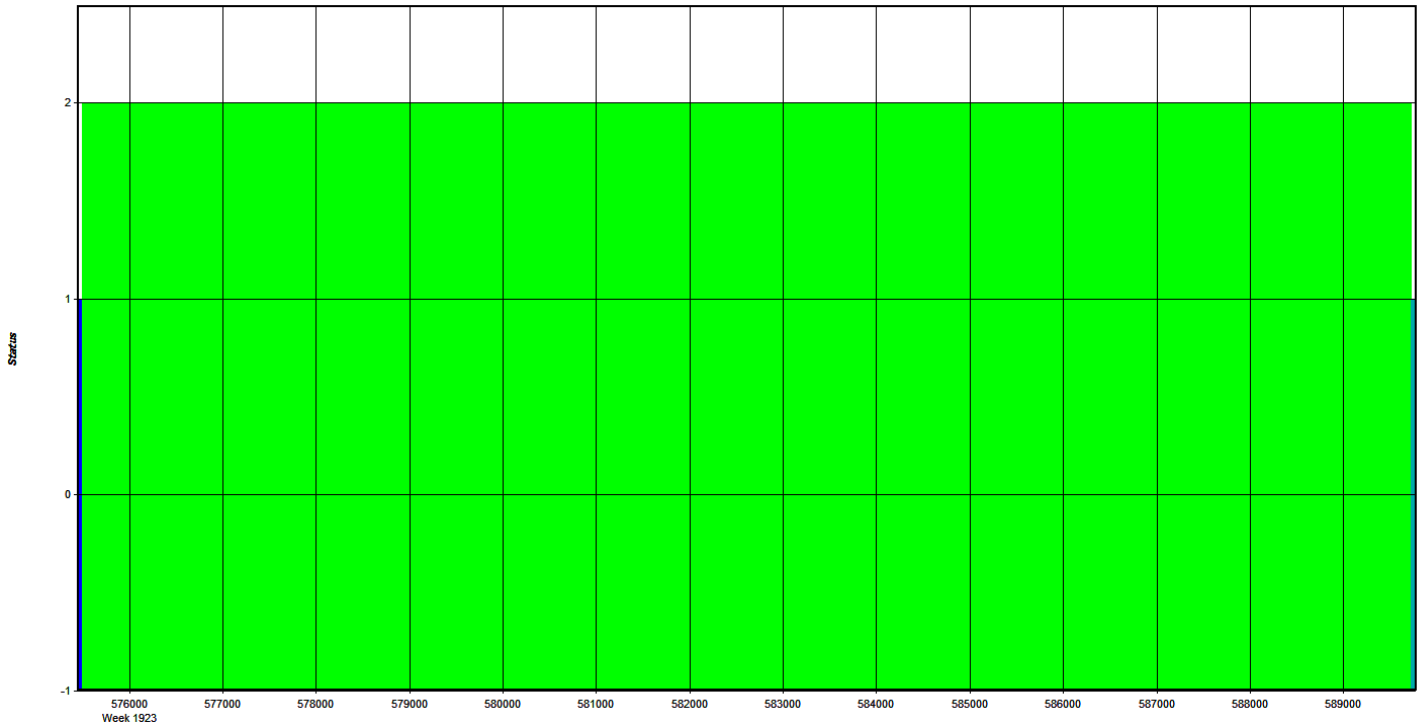

GPS Time (TOW, GMT zone)
 - Float - Forward Fixed - Reverse Fixed - Fixed (2 or more)

Coordinate/Antenna Settings

Master Remote

Base Station
 2: VTC1 Name: VTC1 Disabled
 File: E:\Proc\29178_CT_River\20161119_A_29178_SN7178_N73TM\

Coordinates
 Latitude: North 43 56 21.21809 Compute from PPP
 Longitude: West 72 36 12.56537 Enter Grid Values
 Ellipsoidal height: 405.144 m Enter MSL Height
 Datum: WGS84 Datum Options
 Select From Favorites Add To Favorites Use Average Position

Antenna Height
 From station file: TRM55971.00, NONE View STA File
 Antenna profile: TRM55971.00 Info
 Measured height: 0.000 m
 ARP to L1 offset: 0.067 m
 Applied height: 0.067 m
 Measured to:
 ARP
 L1 Phase Centre
 Compute From Slant

OK Cancel

Coordinate/Antenna Settings
? X

Master
Remote

Base Station

3: VTOX
Name: VTOX
 Disabled

File: E:\Proc\29178_CT_River\20161119_A_29178_SN7178_N73TM\

Coordinates

Latitude:
North
44
00
28.16564
Compute from PPP

Longitude:
West
72
06
51.60957
Enter Grid Values

Ellipsoidal height:
126.405
m
Enter MSL Height

Datum:
WGS84
Datum Options

Select From Favorites
Add To Favorites
Use Average Position

Antenna Height

From station file:
TRM55971.00, NONE
View STA File

Antenna profile:
TRM55971.00
Info

Measured height:
0.000
m

ARP to L1 offset:
0.067
m

Applied height:
0.067
m

Measured to

- ARP
- L1 Phase Centre

Compute From Slant

OK
Cancel

Coordinate/Antenna Settings
? X

Master
Remote

Base Station

1: VTSP
Name: VTSP
 Disabled

File: E:\Proc\29178_CT_River\20161119_A_29178_SN7178_N73TM\

Coordinates

Latitude:
North
43
16
53.24114
Compute from PPP

Longitude:
West
72
28
39.23841
Enter Grid Values

Ellipsoidal height:
156.441
m
Enter MSL Height

Datum:
WGS84
Datum Options

Select From Favorites
Add To Favorites
Use Average Position

Antenna Height

From station file:
TRM55971.00, NONE
View STA File

Antenna profile:
TRM55971.00
Info

Measured height:
0.000
m

ARP to L1 offset:
0.067
m

Applied height:
0.067
m

Measured to

- ARP
- L1 Phase Centre

Compute From Slant

OK
Cancel

Flight Log

Project: QUANTUM SPATIAL **Date:** 11/19/16 **Page:** 1 of 1

Project: CT RIVER BASIN LIDAR **Flight Mgmt File:** 20161119_154800 **Pilot:** J. BERHAM **Co-Pilot:** Techym Ayst

Alt: 6570.5 **Total:** 3.7 **Arr Time (Local):** [Z] **Tot Time Aloft:** [Z]

Dep Apt: SUK **Arr Apt:** LEB **Flyovers:** [X] N **If Y, times: Sta1)** 6:35:17.15 **Sta2)** 1727, 1921

CORS: [X] N **Sta 1:** VTSP **Sta 2:** VTE1 **Flyovers:** Y / N **If Y, times: Sta 1)** [] **Sta 2)** []

GPS Units: Y / N **Sta 1:** [] **Sta 2:** []

Gd Temp beg: 7 °C **End:** 15 °C **OAT beg:** [] °C **End:** [] °C **Altimeter begin:** 2998 **end:** 2979

Type	Serial #	Alt AGL	Alt AMSL	Avg Terr Ht	Max Gdspd	Power	Pulse Rate	Pulse In Air	Turb [0-3]	GPS Altitude	Crab	Gd Spd	End (UTC)	Scan Freq	FOV	Bag GB	End GB	Tot GB	Storage Name	
																				MPA
LIDAR	40	53	7178	7.8	100	260	100	100								318	349	19	4	
Line #	Hdg	Start (UTC)	End (UTC)	Alt AGL	Alt AMSL	GPS Altitude	Crab	Turb [0-3]												
1070	N	1644	1646	1216	7.8															
1069	S	1648	1649	1216	7.9															
1068	N	1653	1654	1316	8.1															
1067	S	1657	1658	1117	7.9															
1066	N	1701	1702	1117	7.9															
1100	E	1705	1706	1117	7.9															
2070	S	1733	1734	1117	8.1															
2069	N	1737	1738	1117	8.1															
2068	S	1741	1743	1117	8.1															
2067	N	1746	1747	1216	8.4															
2062	E	1750	1751	1218	8.3															
2063	N	1808	1809	1216	7.2															
2062	S	1812	1814	1217	7.2															
2061	N	1821	1827	1118	7.2															
2060	S	1830	1837	1018	7.1															
2059	N	1840	1846	1118	7.1															
2058	S	1849	1857	1118	7.1															
2057	N	1859	1906	1118	7.2															

Total Proj Lines: 1912 / 1914 / 173 | 1.2 / 17 / 7.2 | **Lines Remain:** [] | **Online Time:** 2.5 | **Mob Time:** 1.35 | **Notes:** Crossflight - PARTIAL ON 2078

Appendix B

Survey Report



December 15, 2016

Survey Report of
LiDAR Calibration & Quality Control Points

USGS Contract: G16PC00016

VT_Connecticut River Basin
LiDAR_2016_B16

USGS Task Order: G16PD00992

Presented to:



Presented By:





Contents of Report

Project Procedure Summary.....	1
Area of Interest & Point Location Maps.....	5
• Calibration Points.....	6
• NVA – Bare Earth Points.....	7
• NVA - Urban Area Points.....	8
• VVA - Tall Weed Points.....	9
• VVA - Forest Points.....	10
• VVA – Brushland Points.....	11
Final Point Coordinates.....	12
• Calibration Points.....	13
• NVA – Bare Earth Points.....	15
• NVA - Urban Area Points.....	17
• VVA - Tall Weed Points.....	19
• VVA - Forest Points.....	20
• VVA – Brushland Points.....	22



Point Location & Accuracy Data Sheets.....	23
• Calibration Points.....	24
• NVA – Bare Earth Points.....	82
• NVA - Urban Area Points.....	134
• VVA - Tall Weed Points.....	169
• VVA - Forest Points.....	177
• VVA – Brushland Points.....	233



Introduction

Quantum Spatial, Inc. was contracted by USGS under task order G16PD00992 to Survey LiDAR calibration and quality control points in support of VT_Connecticut River Basin LiDAR_2016_B16. This is the report of the technical approach used and detail of each point surveyed.

Project Area

The Project Areas, shown in the figure below, consists of approximately 2,858 square miles.

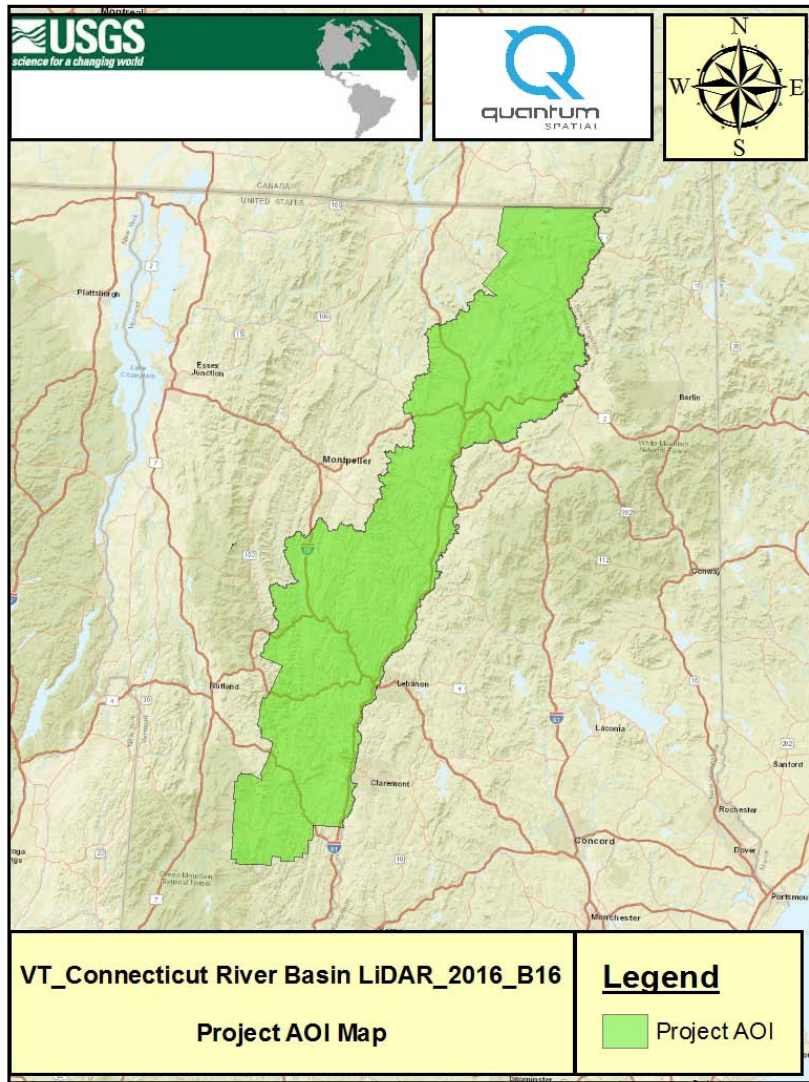



Technical Approach to Land Cover Validation Point Selection

Referencing ASPRS Positional Accuracy Standards for Digital Geospatial Data (Edition 1, Version 1.0, - November, 2014) table C.1 Recommended Number of Checkpoints based on Area, Quantum Spatial calculated that 118 Non-Vegetated Vertical Assessment (NVA) and 87 Vegetated Vertical Assessment (VVA) points are required for this project area.

To ensure that checkpoints were distributed generally proportionate among the various vegetated land cover types, Quantum Spatial used existing USGS Land Cover data to divide both the NVA and VVA categories among the various types, calculating the approximate number of required points in each representative type proportionate to the total project area. The resulting point classes are detailed below:

<u>NVA Class</u>	<u># of Points</u>	<u>VVA Class</u>	<u># of Points</u>
Bare Earth	50	Forested	55
Urban Area	34	Tall Weeds/Crops	7
		Brushland/Trees	3

Quantum Spatial has adopted the philosophy that each vegetative class must be well distributed throughout the project area. While points in varying classes may be near to one another, points of a single vegetative class may not. Proposed point locations are selected with this distribution methodology in mind.

Survey Accuracy Requirements

Given that the survey accuracy of calibration and quality control check points should be 3 times more accurate than the required accuracy of the data set, Quantum Spatial requires that calibration and NVA points are better than 3 centimeters RMSE, both horizontally and vertically, and that VVA points be better than 5 centimeters RMSE, both horizontally and vertically. The surveyed accuracy of each point must be determined through redundant measurements and/or network adjustment using procedures and methodologies that reliably and consistently result in the aforementioned accuracies.

Due to variances in reference control accuracy and adjustment, Quantum Spatial requires that the survey methodology used be explained, so that it can be repeated if necessary.



Field Survey Methodology

Date Range: October 27, 2016 – November 17, 2016

Equipment Used:

Field crews used Trimble R8 dual frequency GNSS receivers as base stations and rovers.

GNSS Methodology:

A combination of RTK GPS, fast static GPS, and traditional surveying methods were used during this project. The RTK GPS survey procedure involved placing a GPS receiver on a check point and collecting three minute “fixed” observations. RTK GPS corrected observations were provided from a Virtual Reference Station System (VRS network – KeyNetGPS, Inc.). KeyNetGPS is a series of continuously operating, high precision GNSS reference stations working through a cellular modem. A minimum of two observations were taken at each check point and the two coordinates were compared and averaged. Published control check points were also located with RTK methods. A Hiper II centimeter accuracy survey grade GPS receiver was used to collect the data.

In areas with limited cellular coverage, the fast static GPS method was used to collect check points. The method consisted of collecting a minimum 30 minutes of data. The data was downloaded and baselines processed to NGS CORS and KeyNET VRS base stations. The network was adjusted holding the CORS as control.

In areas under the tree canopy, traditional surveying methods were used. Pairs of points were collected in open areas using GPS methods. The points were occupied using a Trimble M3 total station to survey the forested check points. Multiple observations were collected at each check point and the coordinates were compared and averaged.

All of the GPS information was downloaded, processed and analyzed using Trimble Business Center processing software.

Overall Project Accuracy Statement

All point coordinates have been reported in the North American Datum of 1983 (NAD83 2011), Vermont State Plane coordinates in meters. Elevations are relative to the North



American Vertical Datum of 1988 (NAVD 88) which were derived using the Geoid 12B model and are reported in meters.

Calibration Points

Average Horizontal RMSE is 0.008 meter.

Average Elevation RMSE is 0.013 meter.

Average 3 dimensional RMSE is 0.015 meter.

NVA Points

Average Horizontal RMSE is 0.008 meter.

Average Elevation RMSE is 0.012 meter.

Average 3 dimensional RMSE is 0.015 meter.

VVA Points

Average Horizontal RMSE is 0.017 meter.

Average Elevation RMSE is 0.021 meter.

Average 3 dimensional RMSE is 0.027 meter.



Project AOI & Point Location Maps

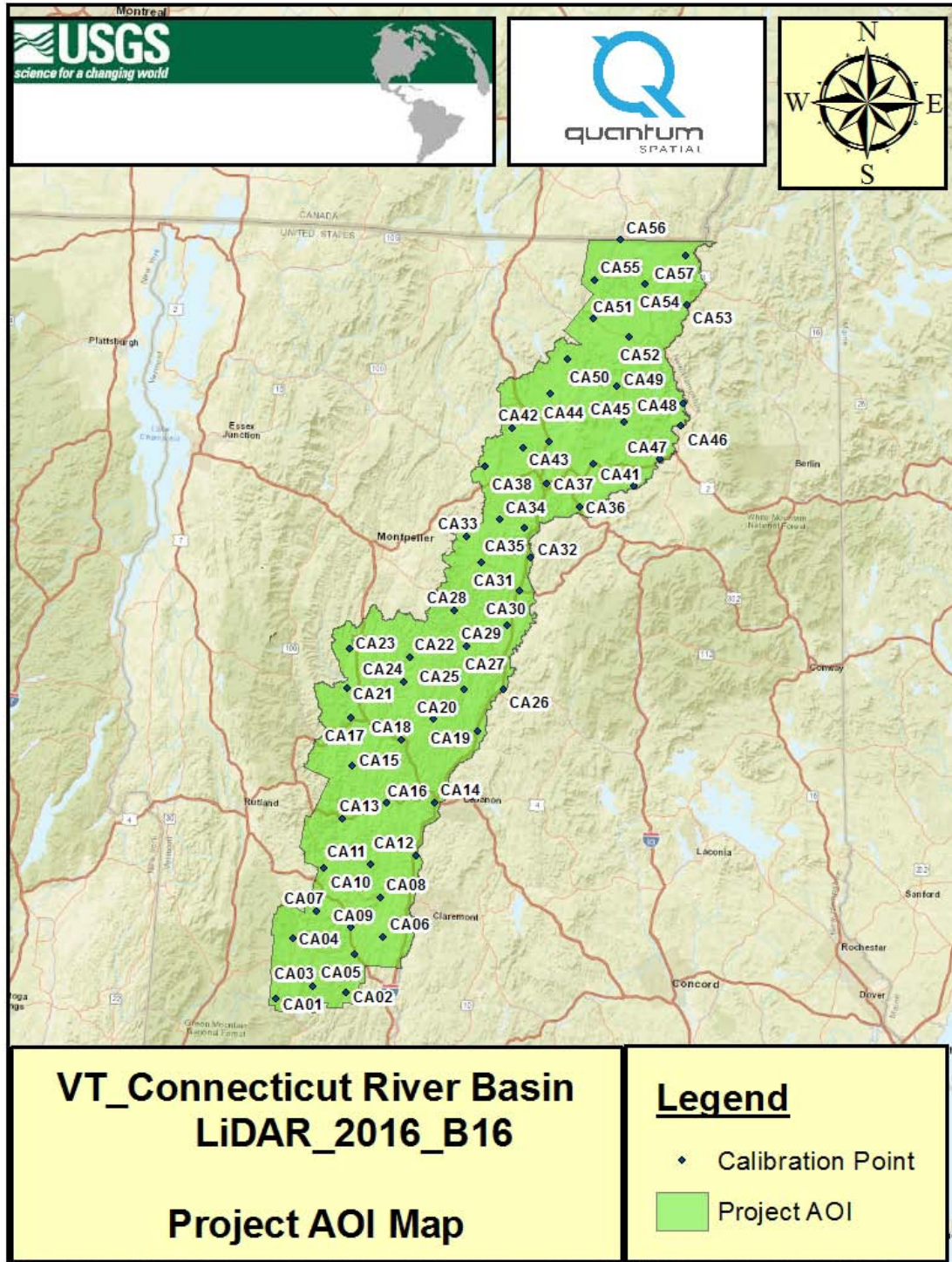

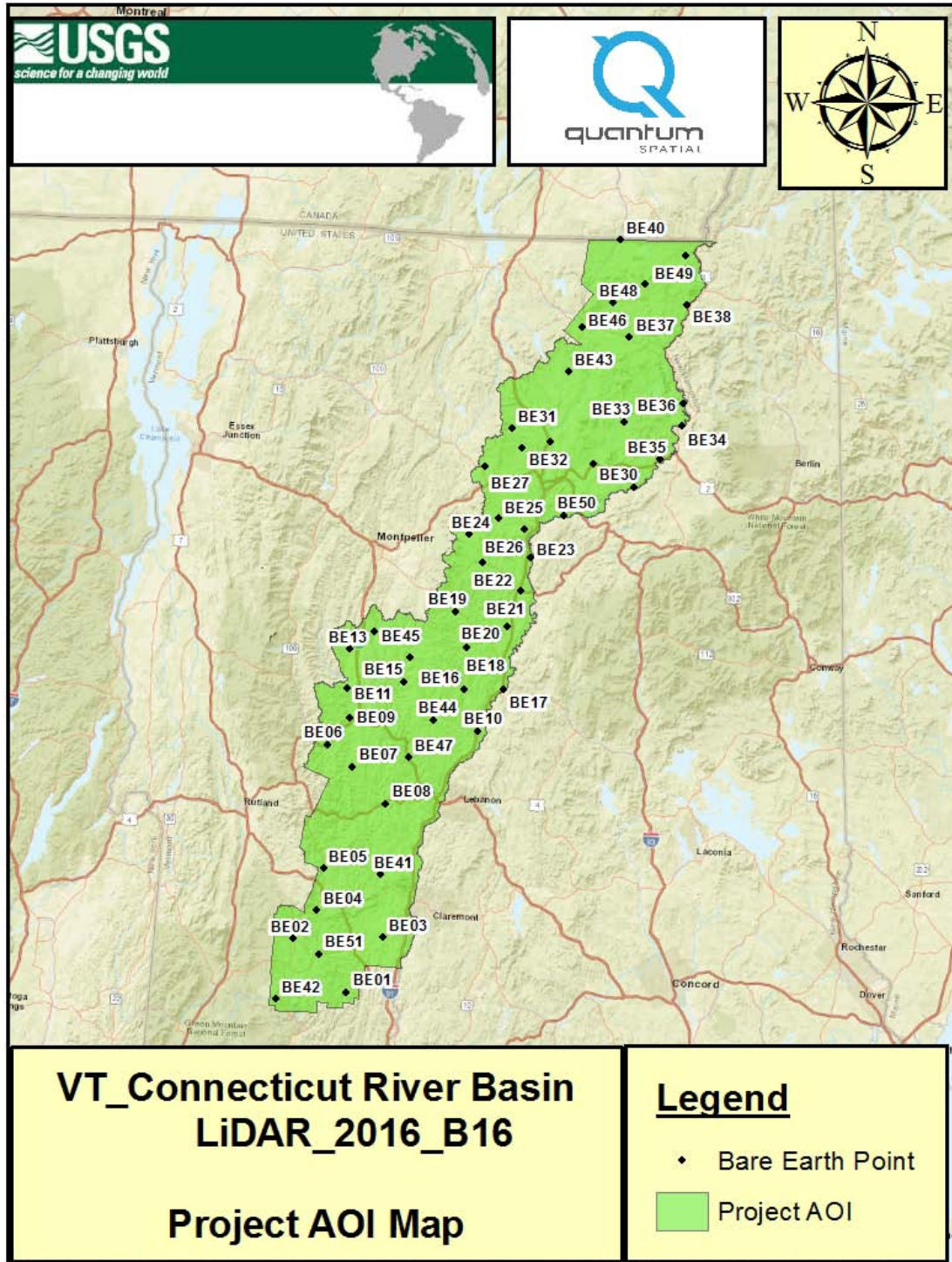

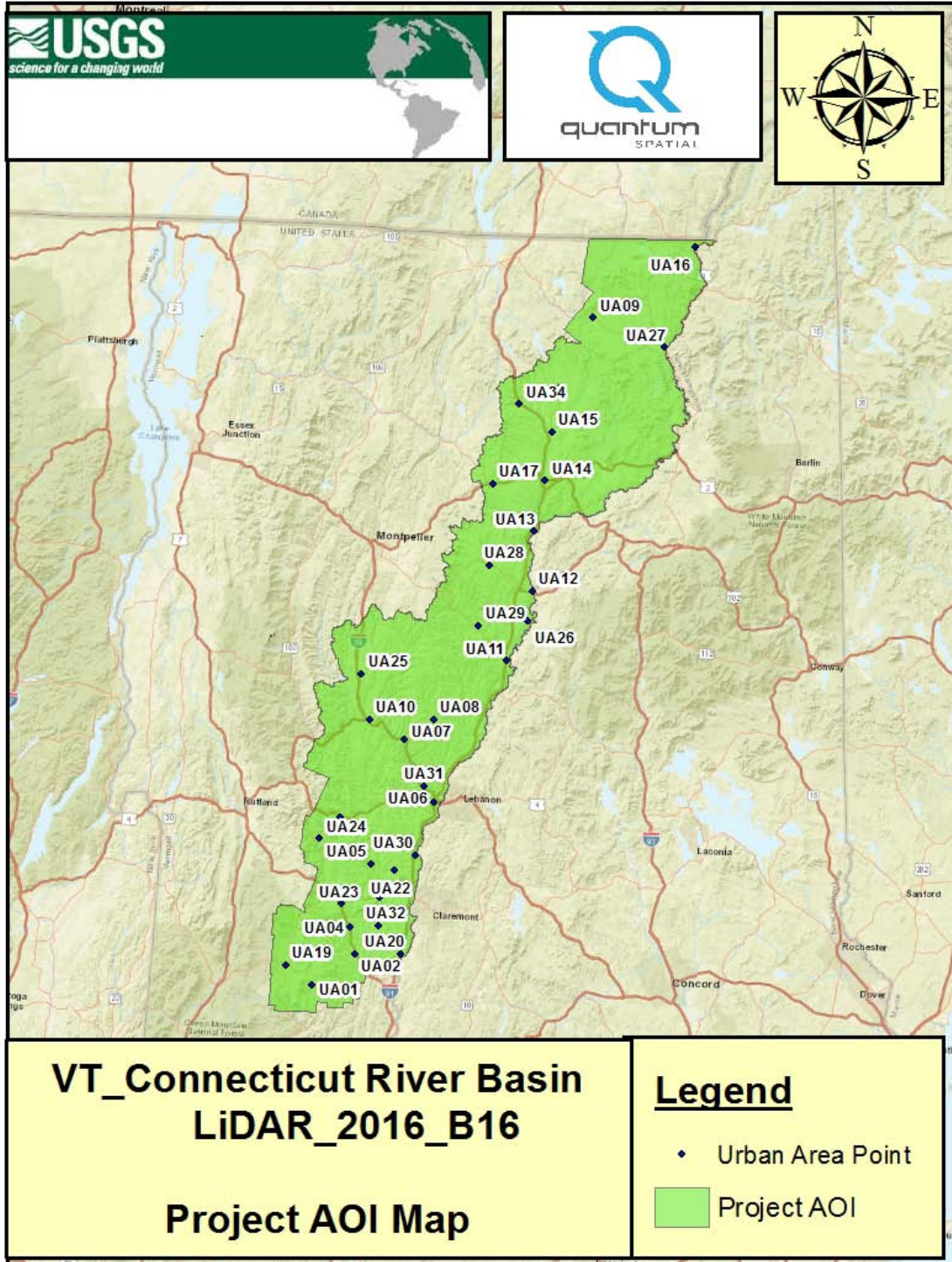

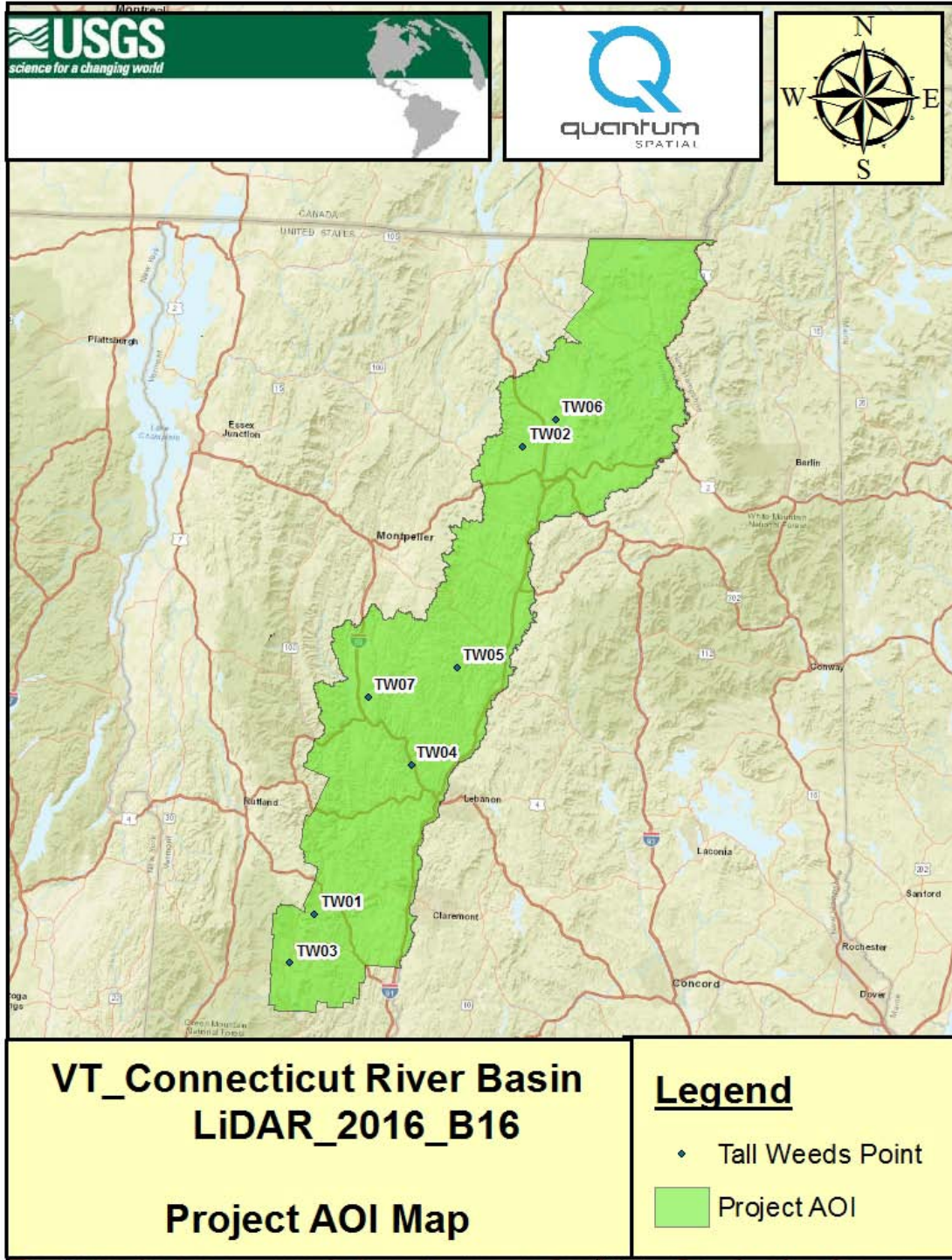

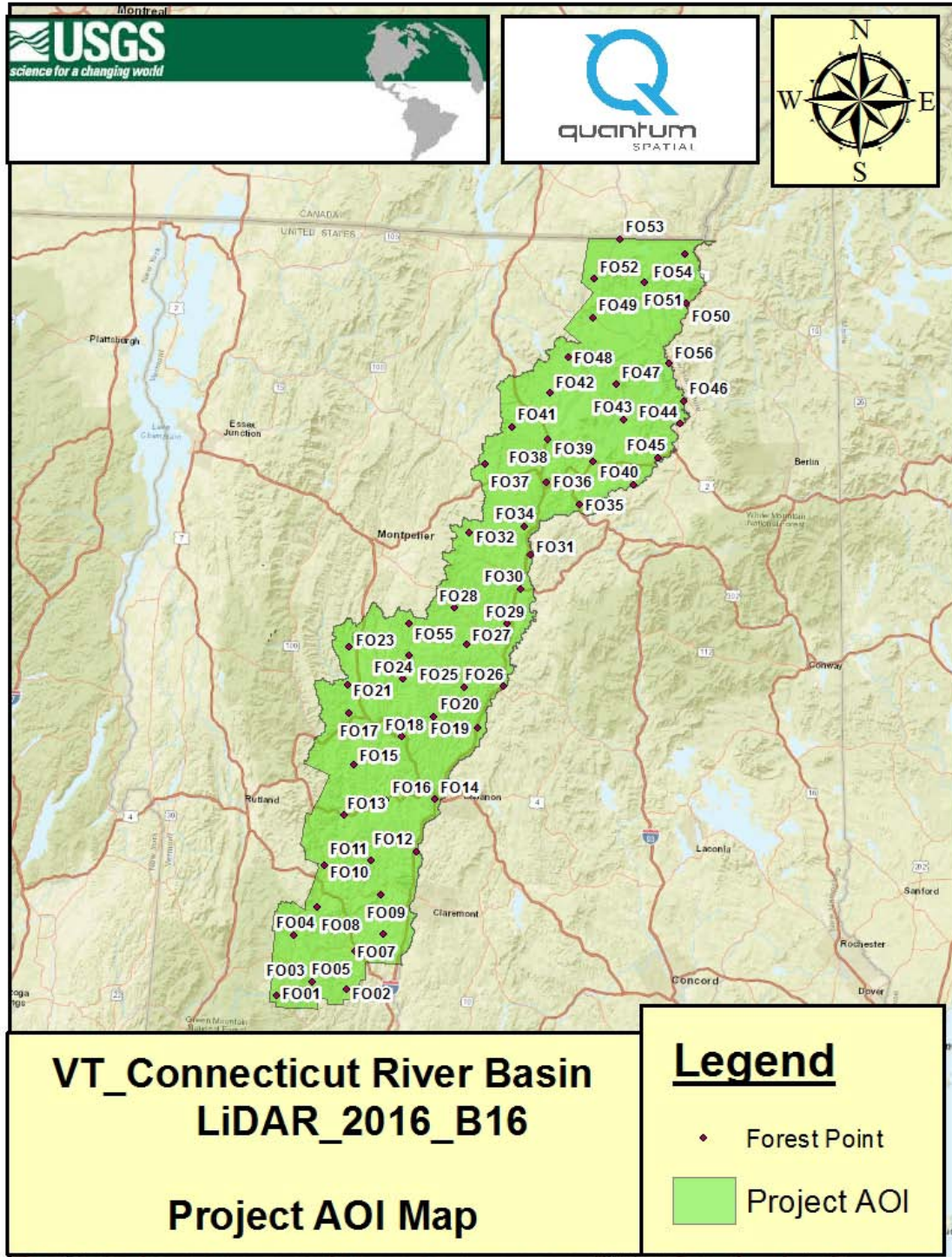

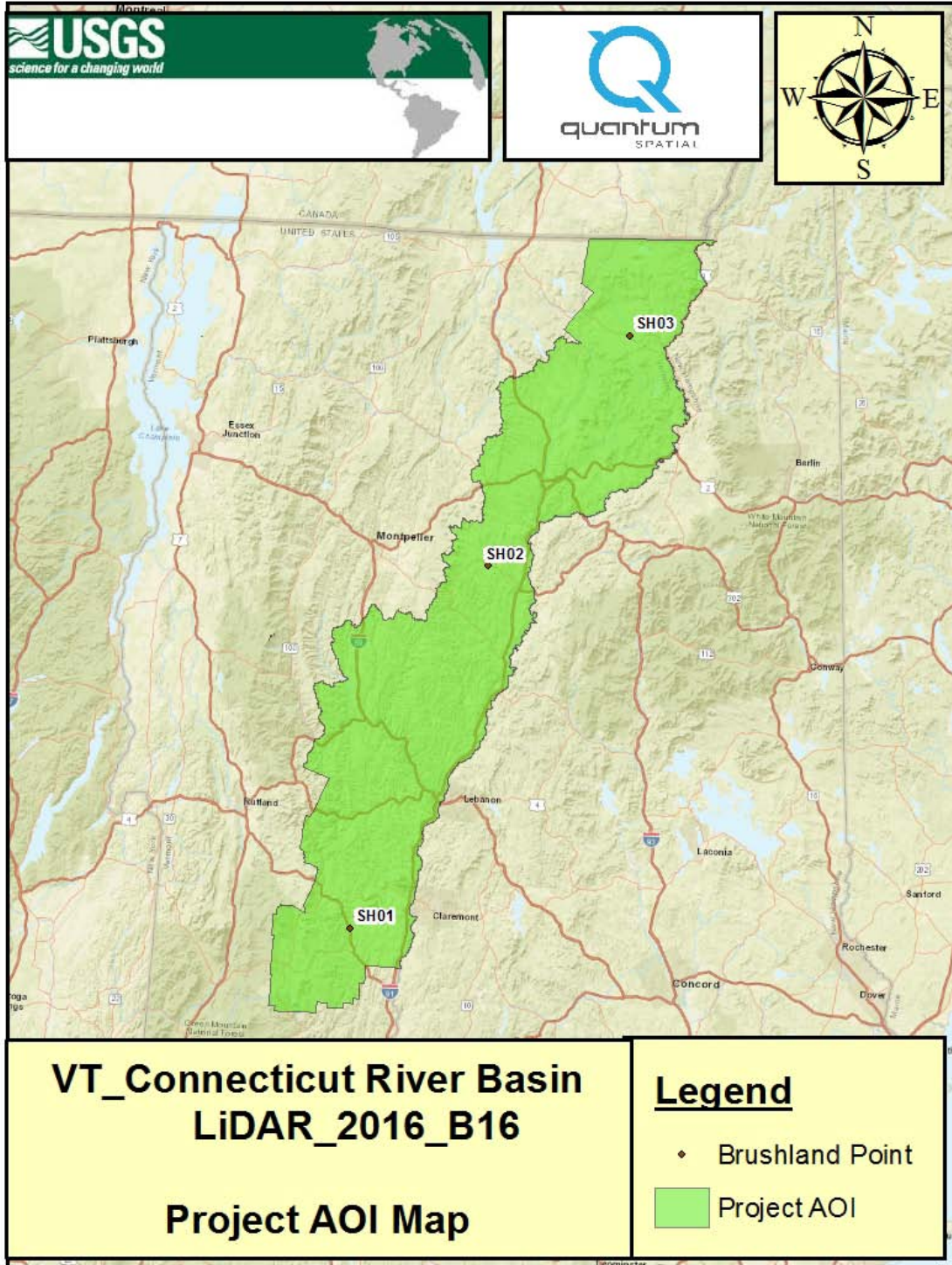



Final Point Coordinates



Calibration Point Coordinates

Horizontal Datum - NAD83(2011)
Vermont State Plane
Vertical Datum - NAVD 88
Geoid - GEOID12B
Units – Meters

Point ID	Northing (m)	Easting (m)	Elev. (m)
CA01	71655.518	472130.114	360.742
CA02	74236.919	490871.294	256.364
CA03	75564.215	481642.506	596.072
CA04	88082.226	475968.572	406.021
CA05	84415.339	492664.940	180.217
CA06	89397.754	500118.996	158.281
CA07	95779.033	482034.019	502.649
CA08	99981.885	498887.149	187.255
CA09	91609.711	491367.289	218.633
CA10	107224.321	483480.963	327.143
CA11	108879.593	496116.206	281.374
CA12	111735.652	508140.925	146.479
CA13	120769.406	487931.397	254.794
CA14	126130.665	512427.045	175.547
CA15	134869.506	490045.671	474.531
CA16	125420.961	499424.232	206.528
CA17	147903.963	488876.432	170.480
CA18	142505.723	502905.262	168.504
CA19	145728.703	523092.220	207.512
CA20	148350.565	511330.842	268.675
CA21	155792.109	487597.200	211.172
CA22	164746.186	504144.424	245.116
CA23	166235.460	487802.333	226.977
CA24	158144.116	502678.201	194.816
CA25	156733.527	519031.052	223.446
CA26	157342.194	529572.496	131.185
CA27	168255.209	519213.563	252.662
CA28	177777.294	515630.979	297.271
CA29	174312.763	529970.810	288.783



CA30	183826.414	532997.281	191.134
CA31	191099.870	522244.732	269.436
CA32	192966.307	535451.003	159.194
CA33	197761.159	518035.543	342.580
CA34	202870.647	526595.061	382.663
CA35	200775.794	533425.012	217.419
CA36	206988.903	547965.942	284.885
CA37	212772.760	538957.260	190.584
CA38	216976.128	522260.214	504.402
CA39	224162.168	538903.386	214.478
CA40	218848.798	551269.978	328.263
CA41	213097.032	562479.755	268.993
CA42	227359.418	529081.337	442.441
CA43	222227.838	532178.238	377.023
CA44	236932.961	538713.971	397.434
CA45	230384.903	559063.266	415.580
CA46	229880.566	574280.460	264.041
CA47	220676.195	568885.328	261.863
CA48	236108.953	574763.305	274.915
CA49	239894.867	556603.457	743.578
CA50	246649.229	543189.692	497.903
CA51	257647.306	549552.156	358.985
CA52	253191.362	559482.235	350.885
CA53	262611.650	574385.555	323.450
CA54	267586.740	563115.305	529.777
CA55	267964.167	549335.036	422.293
CA56	279064.170	555834.567	391.818
CA57	275770.824	573509.249	381.293



Bare Earth Point Coordinates

Horizontal Datum - NAD83(2011)
Vermont State Plane
Vertical Datum - NAVD 88
Geoid - GEOID12B
Units – Meters

Point ID	Northing (m)	Easting (m)	Elev. (m)
BE01	74251.846	490914.888	255.965
BE02	88046.362	475998.939	406.903
BE03	89385.664	500162.044	155.765
BE04	95849.968	482054.549	498.980
BE05	107194.960	483448.600	327.674
BE06	140503.954	482981.377	216.650
BE07	134748.161	490044.503	478.476
BE08	125271.575	499379.101	209.258
BE09	147993.703	488846.064	170.555
BE10	145764.579	523113.292	205.781
BE11	155877.955	487645.075	209.649
BE12	164645.389	504154.290	244.608
BE13	166286.086	487797.606	226.812
BE15	158106.925	502742.460	190.001
BE16	156658.866	519061.959	222.985
BE17	157374.644	529529.440	131.796
BE18	168120.439	519141.703	250.701
BE19	177632.739	515771.503	294.542
BE20	174156.064	529919.670	290.845
BE21	183847.537	533042.553	189.629
BE22	191051.998	522527.008	267.055
BE23	192914.637	535436.201	159.134
BE24	198415.660	518792.398	342.590
BE25	203085.135	526276.199	407.878
BE26	200496.258	533474.582	216.382
BE27	216978.589	522113.353	497.712
BE28	224235.998	539384.097	215.400
BE29	218893.105	551248.535	326.766
BE30	212951.780	562535.251	260.207
BE31	227259.936	529081.733	448.717



BE32	222195.361	531969.151	365.389
BE33	230282.180	558935.898	424.922
BE34	229889.543	574583.462	265.393
BE35	220748.496	568860.606	262.525
BE36	236019.364	574696.394	274.540
BE37	253132.988	559488.257	351.024
BE38	262578.090	574432.330	321.868
BE39	267646.731	563153.863	528.027
BE40	279047.928	555805.350	391.889
BE41	106139.051	498721.428	234.270
BE42	71667.938	472088.591	361.295
BE43	243236.048	543485.694	535.429
BE44	148303.991	511051.744	270.371
BE45	171139.379	494461.643	220.612
BE46	255442.797	546576.020	356.331
BE47	137831.781	504879.610	129.603
BE48	262165.185	554648.390	471.329
BE49	275695.786	573484.363	382.296
BE50	204648.084	544028.727	203.990
BE51	84268.185	483173.283	336.936



Urban Area Point Coordinates

Horizontal Datum - NAD83(2011)
Vermont State Plane
Vertical Datum - NAVD 88
Geoid - GEOID12B
Units – Meters

Point ID	Northing (m)	Easting (m)	Elev. (m)
UA01	75618.566	481627.636	601.461
UA02	84446.438	492698.516	180.085
UA03	99984.522	498844.891	186.992
UA04	91596.635	491356.381	219.489
UA05	108883.995	496091.732	281.955
UA06	126145.505	512368.120	176.958
UA07	142671.104	503691.549	150.611
UA08	148326.038	511330.365	268.384
UA09	257599.837	549459.141	359.527
UA10	147513.676	494077.189	153.238
UA11	164739.962	530299.266	138.488
UA12	183789.281	536260.280	128.332
UA13	199714.985	535948.992	168.791
UA14	213414.152	538512.925	184.862
UA15	226617.476	539627.652	217.751
UA16	277760.698	575906.101	319.621
UA17	212065.139	524399.309	475.012
UA18	99623.609	483621.684	305.500
UA19	80874.822	474343.886	344.507
UA20	85048.705	505100.515	97.938
UA21	120856.621	487410.257	258.538
UA22	107522.717	502343.326	206.722
UA23	97790.150	488485.924	283.067
UA24	115076.732	482087.401	431.231
UA25	159703.291	491478.097	419.757
UA26	175523.734	535415.497	143.984
UA27	250534.648	568950.176	276.727
UA28	190054.647	524334.032	243.563
UA29	173853.596	522268.756	215.094



UA30	111745.657	508080.730	147.225
UA31	130301.843	509566.594	125.447
UA32	92425.126	498649.304	140.333
UA33	238523.816	541327.039	291.339
UA34	233585.977	530623.142	274.764



Tall Weed Point Coordinates

Horizontal Datum - NAD83(2011)
Vermont State Plane
Vertical Datum - NAVD 88
Geoid - GEOID12B
Units – Meters

Point ID	Northing (m)	Easting (m)	Elev. (m)
TW01	94676.026	481642.785	531.892
TW02	222243.007	532154.816	375.814
TW03	81321.434	475558.130	349.558
TW04	135847.869	506063.925	122.108
TW05	162442.648	516931.441	288.195
TW06	229836.842	540596.222	236.101
TW07	153380.692	493422.889	163.847



Forest Point Coordinates

Horizontal Datum - NAD83(2011)
Vermont State Plane
Vertical Datum - NAVD 88
Geoid - GEOID12B
Units – Meters

Point ID	Northing (m)	Easting (m)	Elev. (m)
FO01	71590.536	472128.931	358.549
FO02	74182.274	490829.782	257.342
FO03	75589.378	481583.209	604.294
FO04	87978.710	475959.283	407.543
FO05	84393.696	492608.728	179.520
FO07	89398.534	500094.664	160.056
FO08	95865.722	482087.193	497.286
FO09	99963.447	498910.612	188.963
FO10	107171.199	483503.474	325.036
FO11	108910.970	496114.399	287.964
FO12	111796.502	508073.607	147.186
FO13	120804.282	488091.789	254.610
FO14	126094.857	512457.259	174.260
FO15	134726.064	490107.034	477.426
FO16	125364.204	499402.505	204.737
FO17	148373.672	488252.076	172.641
FO18	142550.915	502782.433	176.046
FO19	145717.124	523044.748	206.601
FO20	148354.358	511296.087	269.935
FO21	155795.675	487651.183	214.260
FO22	164647.041	504027.000	248.158
FO23	166274.923	487749.195	227.142
FO24	158138.208	502567.752	194.028
FO25	156700.854	518981.123	234.007
FO26	157339.419	529609.075	130.690
FO27	168224.457	519242.400	254.686
FO28	177838.189	515687.800	309.149
FO29	174170.564	529911.087	294.922



FO30	183752.610	533019.100	194.960
FO31	193097.704	535517.303	157.804
FO32	198383.477	518771.715	339.970
FO33	202853.233	525962.498	423.508
FO34	200681.660	533563.383	205.109
FO35	207050.818	547951.199	289.131
FO36	212741.258	539011.565	194.278
FO37	217008.025	522237.069	501.707
FO38	224164.598	538857.848	216.077
FO39	218839.858	551230.333	328.329
FO40	213041.379	562447.645	268.262
FO41	227326.347	529041.779	445.222
FO42	236969.540	538668.151	397.307
FO43	230408.906	559039.652	418.805
FO44	229951.890	574305.591	264.439
FO45	220595.192	568608.677	262.503
FO46	236122.203	574783.142	273.346
FO47	239871.648	556633.214	739.340
FO48	246681.663	543286.757	499.553
FO49	257617.541	549378.744	360.154
FO50	262599.569	574435.771	321.742
FO51	267670.951	563124.340	531.536
FO52	267922.905	549322.125	421.934
FO53	279091.262	555834.099	390.012
FO54	275769.978	573472.417	380.101
FO55	173260.257	503484.235	511.418
FO56	246008.100	570598.029	286.828



Brushland Point Coordinates

Horizontal Datum - NAD83(2011)
Vermont State Plane
Vertical Datum - NAVD 88
Geoid - GEOID12B
Units – Meters

Point ID	Northing (m)	Easting (m)	Elev. (m)
SH01	91549.862	491325.881	217.389
SH02	190028.895	524150.670	241.562
SH03	253214.161	559463.935	350.880



Point Data and Accuracy Log Sheets



Calibration Point Log Sheets



Point ID	CA01
Project No.	29178
Project Name	VT CT River Basin
State	Vermont
County	Windham
Quad	Londonderry

	Aerial Target
X	LiDAR Ground Control
	LiDAR QC Point
	New Control
	Photo ID
	Published Control

Coordinate System	
NAD83(2011)	
State Plane VT	
NAVD88	
GEOID12B	
Meters	

Northing	Easting	Elevation
71655.518	472130.114	360.742

Operator	Zeke Ingram
Receiver Model	Trimble R-8, Model 3
Receiver S/N	5046455718
Antenna Height	2.000 Meters

Date (MM-DD-YYYY)	11-11-2016
RMSE Hz	0.009
RMSE Z	0.013
GPS Method	VRN

PHOTOS:





Point ID	CA02
Project No.	29178
Project Name	VT CT River Basin
State	Vermont
County	Windham
Quad	Saxton's River

	Aerial Target
X	LiDAR Ground Control
	LiDAR QC Point
	New Control
	Photo ID
	Published Control

Coordinate System	
NAD83(2011)	
State Plane VT	
NAVD88	
GEOID12B	
Meters	

Northing	Easting	Elevation
74236.919	490871.294	256.364

Operator	Kevin Chapman
Receiver Model	Trimble R-8, Model 3
Receiver S/N	5106561067
Antenna Height	2.000 Meters

Date (MM-DD-YYYY)	11-16-2016
RMSE Hz	0.007
RMSE Z	0.011
GPS Method	VRN

PHOTOS:





Point ID	CA03
Project No.	29178
Project Name	VT CT River Basin
State	Vermont
County	Windham
Quad	Windham

Aerial Target	
X	LiDAR Ground Control
	LiDAR QC Point
	New Control
	Photo ID
	Published Control

Coordinate System	
	NAD83(2011)
	State Plane VT
	NAVD88
	GEOID12B
	Meters

Northing	Easting	Elevation
75564.215	481642.506	596.072

Operator	Zeke Ingram
Receiver Model	Trimble R-8, Model 3
Receiver S/N	5046455718
Antenna Height	2.000 Meters

Date (MM-DD-YYYY)	11-11-2016
RMSE Hz	0.008
RMSE Z	0.011
GPS Method	VRN

PHOTOS:





Point ID	CA04
Project No.	29178
Project Name	VT CT River Basin
State	Vermont
County	Windsor
Quad	Weston

	Aerial Target
X	LiDAR Ground Control
	LiDAR QC Point
	New Control
	Photo ID
	Published Control

Coordinate System
NAD83(2011)
State Plane VT
NAVD88
GEOID12B
Meters

Northing	Easting	Elevation
88082.226	475968.572	406.021

Operator	Zeke Ingram
Receiver Model	Trimble R-8, Model 3
Receiver S/N	5046455718
Antenna Height	2.000 Meters

Date (MM-DD-YYYY)	11-11-2016
RMSE Hz	0.008
RMSE Z	0.015
GPS Method	VRN

PHOTOS:





Point ID	CA05
Project No.	29178
Project Name	VT CT River Basin
State	Vermont
County	Windsor
Quad	Chester

Aerial Target	
X	LiDAR Ground Control
	LiDAR QC Point
	New Control
	Photo ID
	Published Control

Coordinate System	
	NAD83(2011)
	State Plane VT
	NAVD88
	GEOID12B
	Meters

Northing	Easting	Elevation
84415.339	492664.940	180.217

Operator	Zeke Ingram
Receiver Model	Trimble R-8, Model 3
Receiver S/N	5046455718
Antenna Height	2.000 Meters

Date (MM-DD-YYYY)	11-11-2016
RMSE Hz	0.006
RMSE Z	0.010
GPS Method	VRN

PHOTOS:





Point ID	CA06
Project No.	29178
Project Name	VT CT River Basin
State	Vermont
County	Windsor
Quad	Springfield

	Aerial Target
X	LiDAR Ground Control
	LiDAR QC Point
	New Control
	Photo ID
	Published Control

Coordinate System	
NAD83(2011)	
State Plane VT	
NAVD88	
GEOID12B	
Meters	

Northing	Easting	Elevation
89397.754	500118.996	158.281

Operator	Zeke Ingram
Receiver Model	Trimble R-8, Model 3
Receiver S/N	5046455718
Antenna Height	2.000 Meters

Date (MM-DD-YYYY)	11-12-2016
RMSE Hz	0.009
RMSE Z	0.017
GPS Method	VRN

PHOTOS:





Point ID	CA07
Project No.	29178
Project Name	VT CT River Basin
State	Vermont
County	Windsor
Quad	Andover

	Aerial Target
X	LiDAR Ground Control
	LiDAR QC Point
	New Control
	Photo ID
	Published Control

Coordinate System	
NAD83(2011)	
State Plane VT	
NAVD88	
GEOID12B	
Meters	

Northing	Easting	Elevation
95779.033	482034.019	502.649

Operator	Zeke Ingram
Receiver Model	Trimble R-8, Model 3
Receiver S/N	5046455718
Antenna Height	2.000 Meters

Date (MM-DD-YYYY)	11-12-2016
RMSE Hz	0.007
RMSE Z	0.009
GPS Method	VRN

PHOTOS:





Point ID	CA08
Project No.	29178
Project Name	VT CT River Basin
State	Vermont
County	Windsor
Quad	Cavendish

Aerial Target	
X	LiDAR Ground Control
	LiDAR QC Point
	New Control
	Photo ID
	Published Control

Coordinate System	
	NAD83(2011)
	State Plane VT
	NAVD88
	GEOID12B
	Meters

Northing	Easting	Elevation
99981.885	498887.149	187.255

Operator	Zeke Ingram
Receiver Model	Trimble R-8, Model 3
Receiver S/N	5046455718
Antenna Height	2.000 Meters

Date (MM-DD-YYYY)	11-13-2016
RMSE Hz	0.009
RMSE Z	0.013
GPS Method	VRN

PHOTOS:





Point ID	CA09
Project No.	29178
Project Name	VT CT River Basin
State	Vermont
County	Windsor
Quad	Chester

Aerial Target	
X	LiDAR Ground Control
	LiDAR QC Point
	New Control
	Photo ID
	Published Control

Coordinate System	
	NAD83(2011)
	State Plane VT
	NAVD88
	GEOID12B
	Meters

Northing	Easting	Elevation
91609.711	491367.289	218.633

Operator	Zeke Ingram
Receiver Model	Trimble R-8, Model 3
Receiver S/N	5046455718
Antenna Height	2.000 Meters

Date (MM-DD-YYYY)	11-12-2016
RMSE Hz	0.010
RMSE Z	0.016
GPS Method	STATIC

PHOTOS:





Point ID	CA10
Project No.	29178
Project Name	VT CT River Basin
State	Vermont
County	Windsor
Quad	Ludlow

Aerial Target	
X	LiDAR Ground Control
	LiDAR QC Point
	New Control
	Photo ID
	Published Control

Coordinate System	
	NAD83(2011)
	State Plane VT
	NAVD88
	GEOID12B
	Meters

Northing	Easting	Elevation
107224.321	483480.963	327.143

Operator	Zeke Ingram
Receiver Model	Trimble R-8, Model 3
Receiver S/N	5046455718
Antenna Height	2.000 Meters

Date (MM-DD-YYYY)	11-13-2016
RMSE Hz	0.014
RMSE Z	0.022
GPS Method	VRN

PHOTOS:





Point ID	CA11
Project No.	29178
Project Name	VT CT River Basin
State	Vermont
County	Windsor
Quad	Cavendish

	Aerial Target
X	LiDAR Ground Control
	LiDAR QC Point
	New Control
	Photo ID
	Published Control

Coordinate System	
NAD83(2011)	
State Plane VT	
NAVD88	
GEOID12B	
Meters	

Northing	Easting	Elevation
108879.593	496116.206	281.374

Operator	Zeke Ingram
Receiver Model	Trimble R-8, Model 3
Receiver S/N	5046455718
Antenna Height	2.000 Meters

Date (MM-DD-YYYY)	11-13-2016
RMSE Hz	0.017
RMSE Z	0.028
GPS Method	STATIC

PHOTOS:





Point ID	CA12
Project No.	29178
Project Name	VT CT River Basin
State	Vermont
County	Windsor
Quad	Hartland

Aerial Target	
X	LiDAR Ground Control
	LiDAR QC Point
	New Control
	Photo ID
	Published Control

Coordinate System	
	NAD83(2011)
	VT SPCS
	NAVD88
	GEOID12B
	Meters

Northing	Easting	Elevation
111735.652	508140.925	146.479

Operator	Kevin Chapman
Receiver Model	Trimble R-8, Model 3
Receiver S/N	5106461067
Antenna Height	2.000 Meters

Date (MM-DD-YYYY)	11-12-2016
RMSE Hz	0.009
RMSE Z	0.013
GPS Method	VRN

PHOTOS:





Point ID	CA13
Project No.	29178
Project Name	VT CT River Basin
State	Vermont
County	Windsor
Quad	Plymouth

Aerial Target	
X	LiDAR Ground Control
	LiDAR QC Point
	New Control
	Photo ID
	Published Control

Coordinate System	
	NAD83(2011)
	VT SPCS
	NAVD88
	GEOID12B
	Meters

Northing	Easting	Elevation
120769.406	487931.397	254.794

Operator	Kevin Chapman
Receiver Model	Trimble R-8, Model 3
Receiver S/N	5106461067
Antenna Height	2.000 Meters

Date (MM-DD-YYYY)	11-12-2016
RMSE Hz	0.008
RMSE Z	0.011
GPS Method	VRN

PHOTOS:





Point ID	CA14
Project No.	29178
Project Name	VT CT River Basin
State	Vermont
County	Windsor
Quad	Hanover

	Aerial Target
X	LiDAR Ground Control
	LiDAR QC Point
	New Control
	Photo ID
	Published Control

Coordinate System
NAD83(2011)
VT SPCS
NAVD88
GEOID12B
Meters

Northing	Easting	Elevation
126130.665	512427.045	175.547

Operator	Kevin Chapman
Receiver Model	Trimble R-8, Model 3
Receiver S/N	5106461067
Antenna Height	2.000 Meters

Date (MM-DD-YYYY)	11-12-2016
RMSE Hz	0.008
RMSE Z	0.013
GPS Method	VRN

PHOTOS:





Point ID	CA15
Project No.	29178
Project Name	VT CT River Basin
State	Vermont
County	Windsor
Quad	Woodstock North

Aerial Target	
X	LiDAR Ground Control
	LiDAR QC Point
	New Control
	Photo ID
	Published Control

Coordinate System	
	NAD83(2011)
	VT SPCS
	NAVD88
	GEOID12B
	Meters

Northing	Easting	Elevation
134869.506	490045.671	474.531

Operator	Kevin Chapman
Receiver Model	Trimble R-8, Model 3
Receiver S/N	5106461067
Antenna Height	2.000 Meters

Date (MM-DD-YYYY)	11-11-2016
RMSE Hz	0.009
RMSE Z	0.011
GPS Method	Static

PHOTOS:





Point ID	CA16
Project No.	29178
Project Name	VT CT River Basin
State	Vermont
County	Windsor
Quad	Woodstock North

	Aerial Target
X	LiDAR Ground Control
	LiDAR QC Point
	New Control
	Photo ID
	Published Control

Coordinate System	
NAD83(2011)	
VT SPCS	
NAVD88	
GEOID12B	
Meters	

Northing	Easting	Elevation
125420.961	499424.232	206.528

Operator	Kevin Chapman
Receiver Model	Trimble R-8, Model 3
Receiver S/N	5106461067
Antenna Height	2.000 Meters

Date (MM-DD-YYYY)	11-12-2016
RMSE Hz	0.008
RMSE Z	0.012
GPS Method	VRN

PHOTOS:





Point ID	CA17
Project No.	29178
Project Name	VT CT River Basin
State	Vermont
County	Windsor
Quad	Bethel

	Aerial Target
X	LiDAR Ground Control
	LiDAR QC Point
	New Control
	Photo ID
	Published Control

Coordinate System	
NAD83(2011)	
VT SPCS	
NAVD88	
GEOID12B	
Meters	

Northing	Easting	Elevation
147903.963	488876.432	170.480

Operator	Kevin Chapman
Receiver Model	Trimble R-8, Model 3
Receiver S/N	5106461067
Antenna Height	2.000 Meters

Date (MM-DD-YYYY)	11-11-2016
RMSE Hz	0.007
RMSE Z	0.012
GPS Method	VRN

PHOTOS:





Point ID	CA18
Project No.	29178
Project Name	VT CT River Basin
State	Vermont
County	Windsor
Quad	Sharon

Aerial Target	
X	LiDAR Ground Control
	LiDAR QC Point
	New Control
	Photo ID
	Published Control

Coordinate System	
	NAD83(2011)
	VT SPCS
	NAVD88
	GEOID12B
	Meters

Northing	Easting	Elevation
142505.723	502905.262	168.504

Operator	Kevin Chapman
Receiver Model	Trimble R-8, Model 3
Receiver S/N	5106461067
Antenna Height	2.000 Meters

Date (MM-DD-YYYY)	11-11-2016
RMSE Hz	0.008
RMSE Z	0.016
GPS Method	VRN

PHOTOS:





Point ID	CA19
Project No.	29178
Project Name	VT CT River Basin
State	Vermont
County	Orange
Quad	Lyme

Aerial Target	
X	LiDAR Ground Control
	LiDAR QC Point
	New Control
	Photo ID
	Published Control

Coordinate System	
	NAD83(2011)
	VT SPCS
	NAVD88
	GEOID12B
	Meters

Northing	Easting	Elevation
145728.703	523092.220	207.512

Operator	Kevin Chapman
Receiver Model	Trimble R-8, Model 3
Receiver S/N	5106461067
Antenna Height	2.000 Meters

Date (MM-DD-YYYY)	11-04-2016
RMSE Hz	0.007
RMSE Z	0.011
GPS Method	VRN

PHOTOS:





Point ID	CA20
Project No.	29178
Project Name	VT CT River Basin
State	Vermont
County	Orange
Quad	South Strafford

	Aerial Target
X	LiDAR Ground Control
	LiDAR QC Point
	New Control
	Photo ID
	Published Control

Coordinate System
NAD83(2011)
VT SPCS
NAVD88
GEOID12B
Meters

Northing	Easting	Elevation
148350.565	511330.842	268.675

Operator	Kevin Chapman
Receiver Model	Trimble R-8, Model 4
Receiver S/N	5328439860
Antenna Height	2.000 Meters

Date (MM-DD-YYYY)	11-04-2016
RMSE Hz	0.007
RMSE Z	0.009
GPS Method	Static

PHOTOS:





Point ID	CA21
Project No.	29178
Project Name	VT CT River Basin
State	Vermont
County	Orange
Quad	Randolph

	Aerial Target
X	LiDAR Ground Control
	LiDAR QC Point
	New Control
	Photo ID
	Published Control

Coordinate System
NAD83(2011)
VT SPCS
NAVD88
GEOID12B
Meters

Northing	Easting	Elevation
155792.109	487597.200	211.172

Operator	Kevin Chapman
Receiver Model	Trimble R-8, Model 3
Receiver S/N	5106461067
Antenna Height	2.000 Meters

Date (MM-DD-YYYY)	11-01-2016
RMSE Hz	0.008
RMSE Z	0.011
GPS Method	VRN

PHOTOS:





Point ID	CA22
Project No.	29178
Project Name	VT CT River Basin
State	Vermont
County	Orange
Quad	Chelsea

Aerial Target	
X	LiDAR Ground Control
	LiDAR QC Point
	New Control
	Photo ID
	Published Control

Coordinate System	
	NAD83(2011)
	VT SPCS
	NAVD88
	GEOID12B
	Meters

Northing	Easting	Elevation
164746.186	504144.424	245.116

Operator	Kevin Chapman
Receiver Model	Trimble R-8, Model 3
Receiver S/N	5106461067
Antenna Height	2.000 Meters

Date (MM-DD-YYYY)	11-01-2016
RMSE Hz	0.006
RMSE Z	0.008
GPS Method	Static

PHOTOS:





Point ID	CA23
Project No.	29178
Project Name	VT CT River Basin
State	Vermont
County	Orange
Quad	Randolph

Aerial Target	
X	LiDAR Ground Control
	LiDAR QC Point
	New Control
	Photo ID
	Published Control

Coordinate System	
	NAD83(2011)
	VT SPCS
	NAVD88
	GEOID12B
	Meters

Northing	Easting	Elevation
166235.460	487802.333	226.977

Operator	Kevin Chapman
Receiver Model	Trimble R-8, Model 3
Receiver S/N	5106461067
Antenna Height	2.000 Meters

Date (MM-DD-YYYY)	11-01-2016
RMSE Hz	0.007
RMSE Z	0.012
GPS Method	VRN

PHOTOS:





Point ID	CA24
Project No.	29178
Project Name	VT CT River Basin
State	Vermont
County	Orange
Quad	Chelsea

Aerial Target	
X	LiDAR Ground Control
	LiDAR QC Point
	New Control
	Photo ID
	Published Control

Coordinate System	
	NAD83(2011)
	VT SPCS
	NAVD88
	GEOID12B
	Meters

Northing	Easting	Elevation
158144.116	502678.201	194.816

Operator	Kevin Chapman
Receiver Model	Trimble R-8, Model 3
Receiver S/N	5106461067
Antenna Height	2.000 Meters

Date (MM-DD-YYYY)	11-04-2016
RMSE Hz	0.007
RMSE Z	0.013
GPS Method	VRN

PHOTOS:





Point ID	CA25
Project No.	29178
Project Name	VT CT River Basin
State	Vermont
County	Orange
Quad	Vershire

Aerial Target	
X	LiDAR Ground Control
	LiDAR QC Point
	New Control
	Photo ID
	Published Control

Coordinate System	
	NAD83(2011)
	VT SPCS
	NAVD88
	GEOID12B
	Meters

Northing	Easting	Elevation
156733.527	519031.052	223.446

Operator	Kevin Chapman
Receiver Model	Trimble R-8, Model 3
Receiver S/N	5106461067
Antenna Height	2.000 Meters

Date (MM-DD-YYYY)	11-01-2016
RMSE Hz	0.008
RMSE Z	0.011
GPS Method	Static

PHOTOS:





Point ID	CA26
Project No.	29178
Project Name	VT CT River Basin
State	Vermont
County	Orange
Quad	Fairlee

Aerial Target	
X	LiDAR Ground Control
	LiDAR QC Point
	New Control
	Photo ID
	Published Control

Coordinate System	
	NAD83(2011)
	VT SPCS
	NAVD88
	GEOID12B
	Meters

Northing	Easting	Elevation
157342.194	529572.496	131.185

Operator	Kevin Chapman
Receiver Model	Trimble R-8, Model 3
Receiver S/N	5106461067
Antenna Height	2.000 Meters

Date (MM-DD-YYYY)	11-04-2016
RMSE Hz	0.008
RMSE Z	0.011
GPS Method	VRN

PHOTOS:





Point ID	CA27
Project No.	29178
Project Name	VT CT River Basin
State	Vermont
County	Orange
Quad	West Topsham

Aerial Target	
X	LiDAR Ground Control
	LiDAR QC Point
	New Control
	Photo ID
	Published Control

Coordinate System	
	NAD83(2011)
	VT SPCS
	NAVD88
	GEOID12B
	Meters

Northing	Easting	Elevation
168255.209	519213.563	252.662

Operator	Kevin Chapman
Receiver Model	Trimble R-8, Model 3
Receiver S/N	5106461067
Antenna Height	2.000 Meters

Date (MM-DD-YYYY)	10-31-2016
RMSE Hz	0.007
RMSE Z	0.010
GPS Method	VRN

PHOTOS:





Point ID	CA28
Project No.	29178
Project Name	VT CT River Basin
State	Vermont
County	Orange
Quad	West Topsham

	Aerial Target
X	LiDAR Ground Control
	LiDAR QC Point
	New Control
	Photo ID
	Published Control

Coordinate System
NAD83(2011)
VT SPCS
NAVD88
GEOID12B
Meters

Northing	Easting	Elevation
177777.294	515630.979	297.271

Operator	Kevin Chapman
Receiver Model	Trimble R-8, Model 3
Receiver S/N	5106461067
Antenna Height	2.000 Meters

Date (MM-DD-YYYY)	10-31-2016
RMSE Hz	0.008
RMSE Z	0.012
GPS Method	VRN

PHOTOS:





Point ID	CA29
Project No.	29178
Project Name	VT CT River Basin
State	Vermont
County	Orange
Quad	East Corinth

Aerial Target	
X	LiDAR Ground Control
	LiDAR QC Point
	New Control
	Photo ID
	Published Control

Coordinate System	
	NAD83(2011)
	VT SPCS
	NAVD88
	GEOID12B
	Meters

Northing	Easting	Elevation
174312.763	529970.810	288.783

Operator	Kevin Chapman
Receiver Model	Trimble R-8, Model 3
Receiver S/N	5106461067
Antenna Height	2.000 Meters

Date (MM-DD-YYYY)	11-02-2016
RMSE Hz	0.009
RMSE Z	0.017
GPS Method	VRN

PHOTOS:





Point ID	CA30
Project No.	29178
Project Name	VT CT River Basin
State	Vermont
County	Orange
Quad	Woodsville

Aerial Target	
X	LiDAR Ground Control
	LiDAR QC Point
	New Control
	Photo ID
	Published Control

Coordinate System	
	NAD83(2011)
	VT SPCS
	NAVD88
	GEOID12B
	Meters

Northing	Easting	Elevation
183826.414	532997.281	191.134

Operator	Kevin Chapman
Receiver Model	Trimble R-8, Model 3
Receiver S/N	5106461067
Antenna Height	2.000 Meters

Date (MM-DD-YYYY)	10-28-2016
RMSE Hz	0.006
RMSE Z	0.007
GPS Method	Static

PHOTOS:





Point ID	CA31
Project No.	29178
Project Name	VT CT River Basin
State	Vermont
County	Caledonia
Quad	Groton

	Aerial Target
X	LiDAR Ground Control
	LiDAR QC Point
	New Control
	Photo ID
	Published Control

Coordinate System
NAD83(2011)
VT SPCS
NAVD88
GEOID12B
Meters

Northing	Easting	Elevation
191099.870	522244.732	269.436

Operator	Kevin Chapman
Receiver Model	Trimble R-8, Model 3
Receiver S/N	5106461067
Antenna Height	2.000 Meters

Date (MM-DD-YYYY)	10-29-2016
RMSE Hz	0.007
RMSE Z	0.008
GPS Method	Static

PHOTOS:





Point ID	CA32
Project No.	29178
Project Name	VT CT River Basin
State	Vermont
County	Caledonia
Quad	Woodsville

Aerial Target	
X	LiDAR Ground Control
	LiDAR QC Point
	New Control
	Photo ID
	Published Control

Coordinate System	
	NAD83(2011)
	VT SPCS
	NAVD88
	GEOID12B
	Meters

Northing	Easting	Elevation
192966.307	535451.003	159.194

Operator	Kevin Chapman
Receiver Model	Trimble R-8, Model 3
Receiver S/N	5106461067
Antenna Height	2.000 Meters

Date (MM-DD-YYYY)	10-31-2016
RMSE Hz	0.007
RMSE Z	0.009
GPS Method	Static

PHOTOS:





Point ID	CA33
Project No.	29178
Project Name	VT CT River Basin
State	Vermont
County	Caledonia
Quad	Marshfield

	Aerial Target
X	LiDAR Ground Control
	LiDAR QC Point
	New Control
	Photo ID
	Published Control

Coordinate System
NAD83(2011)
VT SPCS
NAVD88
GEOID12B
Meters

Northing	Easting	Elevation
197761.159	518035.543	342.580

Operator	Kevin Chapman
Receiver Model	Trimble R-8, Model 3
Receiver S/N	5106461067
Antenna Height	2.000 Meters

Date (MM-DD-YYYY)	10-30-2016
RMSE Hz	0.007
RMSE Z	0.009
GPS Method	Static

PHOTOS:





Point ID	CA34
Project No.	29178
Project Name	VT CT River Basin
State	Vermont
County	Caledonia
Quad	Peachem

Aerial Target	
X	LiDAR Ground Control
	LiDAR QC Point
	New Control
	Photo ID
	Published Control

Coordinate System	
	NAD83(2011)
	VT SPCS
	NAVD88
	GEOID12B
	Meters

Northing	Easting	Elevation
202870.647	526595.061	382.663

Operator	Kevin Chapman
Receiver Model	Trimble R-8, Model 3
Receiver S/N	5106461067
Antenna Height	2.000 Meters

Date (MM-DD-YYYY)	10-30-2016
RMSE Hz	0.006
RMSE Z	0.008
GPS Method	Static

PHOTOS:





Point ID	CA35
Project No.	29178
Project Name	VT CT River Basin
State	Vermont
County	Caledonia
Quad	Barnet

	Aerial Target
X	LiDAR Ground Control
	LiDAR QC Point
	New Control
	Photo ID
	Published Control

Coordinate System	
NAD83(2011)	
VT SPCS	
NAVD88	
GEOID12B	
Meters	

Northing	Easting	Elevation
200775.794	533425.012	217.419

Operator	Kevin Chapman
Receiver Model	Trimble R-8, Model 3
Receiver S/N	5106461067
Antenna Height	2.000 Meters

Date (MM-DD-YYYY)	10-30-2016
RMSE Hz	0.006
RMSE Z	0.011
GPS Method	Static

PHOTOS:





Point ID	CA36
Project No.	29178
Project Name	VT CT River Basin
State	Vermont
County	Caledonia
Quad	Lower Waterford

Aerial Target	
X	LiDAR Ground Control
	LiDAR QC Point
	New Control
	Photo ID
	Published Control

Coordinate System	
	NAD83(2011)
	State Plane VT
	NAVD88
	GEOID12B
	Meters

Northing	Easting	Elevation
206988.903	547965.942	284.885

Operator	Zeke Ingram
Receiver Model	Trimble R-8, Model 3
Receiver S/N	5046455718
Antenna Height	2.000 Meters

Date (MM-DD-YYYY)	10-27-2016
RMSE Hz	0.007
RMSE Z	0.010
GPS Method	Static

PHOTOS:





Point ID	CA37
Project No.	29178
Project Name	VT CT River Basin
State	Vermont
County	Caledonia
Quad	Saint Johnsbury

Aerial Target	
X	LiDAR Ground Control
	LiDAR QC Point
	New Control
	Photo ID
	Published Control

Coordinate System	
	NAD83(2011)
	State Plane VT
	NAVD88
	GEOID12B
	Meters

Northing	Easting	Elevation
212772.760	538957.260	190.584

Operator	Zeke Ingram
Receiver Model	Trimble R-8, Model 3
Receiver S/N	5046455718
Antenna Height	2.000 Meters

Date (MM-DD-YYYY)	10-31-2016
RMSE Hz	0.006
RMSE Z	0.008
GPS Method	Static

PHOTOS:





Point ID	CA38
Project No.	29178
Project Name	VT CT River Basin
State	Vermont
County	Caledonia
Quad	Joes Pond

Aerial Target	
X	LiDAR Ground Control
	LiDAR QC Point
	New Control
	Photo ID
	Published Control

Coordinate System	
	NAD83(2011)
	State Plane VT
	NAVD88
	GEOID12B
	Meters

Northing	Easting	Elevation
216976.128	522260.214	504.402

Operator	Zeke Ingram
Receiver Model	Trimble R-8, Model 3
Receiver S/N	5046455718
Antenna Height	2.000 Meters

Date (MM-DD-YYYY)	10-31-2016
RMSE Hz	0.006
RMSE Z	0.008
GPS Method	Static

PHOTOS:





Point ID	CA39
Project No.	29178
Project Name	VT CT River Basin
State	Vermont
County	Caledonia
Quad	Lyndonville

Aerial Target	
X	LiDAR Ground Control
	LiDAR QC Point
	New Control
	Photo ID
	Published Control

Coordinate System	
	NAD83(2011)
	State Plane VT
	NAVD88
	GEOID12B
	Meters

Northing	Easting	Elevation
224162.168	538903.386	214.478

Operator	Zeke Ingram
Receiver Model	Trimble R-8, Model 3
Receiver S/N	5046455718
Antenna Height	2.000 Meters

Date (MM-DD-YYYY)	10-30-2016
RMSE Hz	0.006
RMSE Z	0.012
GPS Method	Static

PHOTOS:





Point ID	CA40
Project No.	29178
Project Name	VT CT River Basin
State	Vermont
County	Essex
Quad	Miles Pond

	Aerial Target
X	LiDAR Ground Control
	LiDAR QC Point
	New Control
	Photo ID
	Published Control

Coordinate System
NAD83(2011)
State Plane VT
NAVD88
GEOID12B
Meters

Northing	Easting	Elevation
218848.798	551269.978	328.263

Operator	Zeke Ingram
Receiver Model	Trimble R-8, Model 3
Receiver S/N	5046455718
Antenna Height	2.000 Meters

Date (MM-DD-YYYY)	10-30-2016
RMSE Hz	0.005
RMSE Z	0.008
GPS Method	Static

PHOTOS:

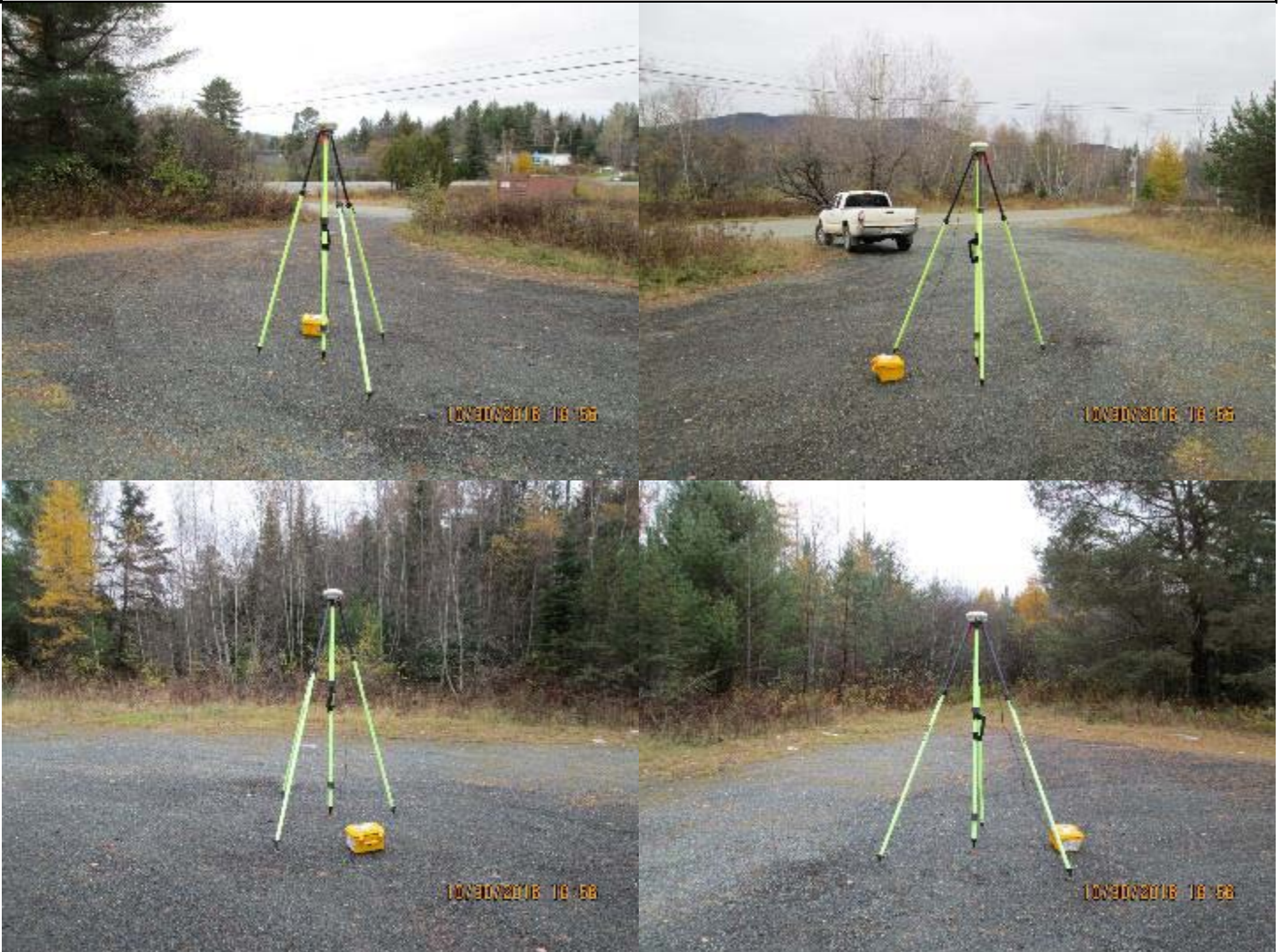



Point ID	CA41
Project No.	29178
Project Name	VT CT River Basin
State	Vermont
County	Essex
Quad	Gilman

Aerial Target	
X	LiDAR Ground Control
	LiDAR QC Point
	New Control
	Photo ID
	Published Control

Coordinate System	
	NAD83(2011)
	State Plane VT
	NAVD88
	GEOID12B
	Meters

Northing	Easting	Elevation
213097.032	562479.755	268.993

Operator	Zeke Ingram
Receiver Model	Trimble R-8, Model 3
Receiver S/N	5046455718
Antenna Height	2.000 Meters

Date (MM-DD-YYYY)	10-27-2016
RMSE Hz	0.006
RMSE Z	0.010
GPS Method	Static

PHOTOS:





Point ID	CA42
Project No.	29178
Project Name	VT CT River Basin
State	Vermont
County	Caledonia
Quad	Stannard

	Aerial Target
X	LiDAR Ground Control
	LiDAR QC Point
	New Control
	Photo ID
	Published Control

Coordinate System	
NAD83(2011)	
State Plane VT	
NAVD88	
GEOID12B	
Meters	

Northing	Easting	Elevation
227359.418	529081.337	442.441

Operator	Zeke Ingram
Receiver Model	Trimble R-8, Model 3
Receiver S/N	5046455718
Antenna Height	2.000 Meters

Date (MM-DD-YYYY)	10-31-2016
RMSE Hz	0.007
RMSE Z	0.009
GPS Method	Static

PHOTOS:





Point ID	CA43
Project No.	29178
Project Name	VT CT River Basin
State	Vermont
County	Caledonia
Quad	Saint Johnsbury

Aerial Target	
X	LiDAR Ground Control
	LiDAR QC Point
	New Control
	Photo ID
	Published Control

Coordinate System	
	NAD83(2011)
	State Plane VT
	NAVD88
	GEOID12B
	Meters

Northing	Easting	Elevation
222227.838	532178.238	377.023

Operator	Zeke Ingram
Receiver Model	Trimble R-8, Model 3
Receiver S/N	5407453971
Antenna Height	2.000 Meters

Date (MM-DD-YYYY)	10-31-2016
RMSE Hz	0.006
RMSE Z	0.008
GPS Method	Static

PHOTOS:





Point ID	CA44
Project No.	29178
Project Name	VT CT River Basin
State	Vermont
County	Caledonia
Quad	Sutton

	Aerial Target
X	LiDAR Ground Control
	LiDAR QC Point
	New Control
	Photo ID
	Published Control

Coordinate System
NAD83(2011)
State Plane VT
NAVD88
GEOID12B
Meters

Northing	Easting	Elevation
236932.961	538713.971	397.434

Operator	Zeke Ingram
Receiver Model	Trimble R-8, Model 3
Receiver S/N	5046455718
Antenna Height	2.000 Meters

Date (MM-DD-YYYY)	10-30-2016
RMSE Hz	0.005
RMSE Z	0.007
GPS Method	Static

PHOTOS:





Point ID	CA45
Project No.	29178
Project Name	VT CT River Basin
State	Vermont
County	Essex
Quad	Gallup Mills

	Aerial Target
X	LiDAR Ground Control
	LiDAR QC Point
	New Control
	Photo ID
	Published Control

Coordinate System	
NAD83(2011)	
State Plane VT	
NAVD88	
GEOID12B	
Meters	

Northing	Easting	Elevation
230384.903	559063.266	415.580

Operator	Zeke Ingram
Receiver Model	Trimble R-8, Model 3
Receiver S/N	5046455718
Antenna Height	2.000 Meters

Date (MM-DD-YYYY)	10-30-2016
RMSE Hz	0.006
RMSE Z	0.009
GPS Method	Static

PHOTOS:





Point ID	CA46
Project No.	29178
Project Name	VT CT River Basin
State	Vermont
County	Essex
Quad	Groveton

	Aerial Target
X	LiDAR Ground Control
	LiDAR QC Point
	New Control
	Photo ID
	Published Control

Coordinate System
NAD83(2011)
State Plane VT
NAVD88
GEOID12B
Meters

Northing	Easting	Elevation
229880.566	574280.460	264.041

Operator	Zeke Ingram
Receiver Model	Trimble R-8, Model 3
Receiver S/N	5046455718
Antenna Height	2.000 Meters

Date (MM-DD-YYYY)	10-27-2016
RMSE Hz	0.009
RMSE Z	0.013
GPS Method	Static

PHOTOS:





Point ID	CA47
Project No.	29178
Project Name	VT CT River Basin
State	Vermont
County	Essex
Quad	Gilman

	Aerial Target
X	LiDAR Ground Control
	LiDAR QC Point
	New Control
	Photo ID
	Published Control

Coordinate System	
NAD83(2011)	
State Plane VT	
NAVD88	
GEOID12B	
Meters	

Northing	Easting	Elevation
220676.195	568885.328	261.863

Operator	Zeke Ingram
Receiver Model	Trimble R-8, Model 3
Receiver S/N	5046455718
Antenna Height	2.000 Meters

Date (MM-DD-YYYY)	10-27-2016
RMSE Hz	0.005
RMSE Z	0.010
GPS Method	Static

PHOTOS:





Point ID	CA48
Project No.	29178
Project Name	VT CT River Basin
State	Vermont
County	Essex
Quad	Groveton

	Aerial Target
X	LiDAR Ground Control
	LiDAR QC Point
	New Control
	Photo ID
	Published Control

Coordinate System	
NAD83(2011)	
State Plane VT	
NAVD88	
GEOID12B	
Meters	

Northing	Easting	Elevation
236108.953	574763.305	274.915

Operator	Zeke Ingram
Receiver Model	Trimble R-8, Model 3
Receiver S/N	5046455718
Antenna Height	2.000 Meters

Date (MM-DD-YYYY)	10-27-2016
RMSE Hz	0.011
RMSE Z	0.015
GPS Method	Static

PHOTOS:





Point ID	CA49
Project No.	29178
Project Name	VT CT River Basin
State	Vermont
County	Essex
Quad	Seneca Mountain

	Aerial Target
X	LiDAR Ground Control
	LiDAR QC Point
	New Control
	Photo ID
	Published Control

Coordinate System	
NAD83(2011)	
State Plane VT	
NAVD88	
GEOID12B	
Meters	

Northing	Easting	Elevation
239894.867	556603.457	743.578

Operator	Zeke Ingram
Receiver Model	Trimble R-8, Model 3
Receiver S/N	5046455718
Antenna Height	2.000 Meters

Date (MM-DD-YYYY)	10-30-2016
RMSE Hz	0.009
RMSE Z	0.010
GPS Method	Static

PHOTOS:





Point ID	CA50
Project No.	29178
Project Name	VT CT River Basin
State	Vermont
County	Caledonia
Quad	West Burke

Aerial Target	
X	LiDAR Ground Control
	LiDAR QC Point
	New Control
	Photo ID
	Published Control

Coordinate System	
	NAD83(2011)
	State Plane VT
	NAVD88
	GEOID12B
	Meters

Northing	Easting	Elevation
246649.229	543189.692	497.903

Operator	Zeke Ingram
Receiver Model	Trimble R-8, Model 3
Receiver S/N	5046455718
Antenna Height	2.000 Meters

Date (MM-DD-YYYY)	11-1-2016
RMSE Hz	0.008
RMSE Z	0.011
GPS Method	VRN

PHOTOS:





Point ID	CA51
Project No.	29178
Project Name	VT CT River Basin
State	Vermont
County	Essex
Quad	Island Pond

Aerial Target	
X	LiDAR Ground Control
	LiDAR QC Point
	New Control
	Photo ID
	Published Control

Coordinate System	
	NAD83(2011)
	State Plane VT
	NAVD88
	GEOID12B
	Meters

Northing	Easting	Elevation
257647.306	549552.156	358.985

Operator	Zeke Ingram
Receiver Model	Trimble R-8, Model 3
Receiver S/N	5046455718
Antenna Height	2.000 Meters

Date (MM-DD-YYYY)	11-1-2016
RMSE Hz	0.009
RMSE Z	0.013
GPS Method	VRN

PHOTOS:





Point ID	CA52
Project No.	29178
Project Name	VT CT River Basin
State	Vermont
County	Essex
Quad	Bloomfield

	Aerial Target
X	LiDAR Ground Control
	LiDAR QC Point
	New Control
	Photo ID
	Published Control

Coordinate System
NAD83(2011)
State Plane VT
NAVD88
GEOID12B
Meters

Northing	Easting	Elevation
253191.362	559482.235	350.885

Operator	Zeke Ingram
Receiver Model	Trimble R-8, Model 3
Receiver S/N	5046455718
Antenna Height	2.000 Meters

Date (MM-DD-YYYY)	11-1-2016
RMSE Hz	0.008
RMSE Z	0.011
GPS Method	VRN

PHOTOS:





Point ID	CA53
Project No.	29178
Project Name	VT CT River Basin
State	Vermont
County	Essex
Quad	Tinkerville

	Aerial Target
X	LiDAR Ground Control
	LiDAR QC Point
	New Control
	Photo ID
	Published Control

Coordinate System	
NAD83(2011)	
State Plane VT	
NAVD88	
GEOID12B	
Meters	

Northing	Easting	Elevation
262611.650	574385.555	323.450

Operator	Zeke Ingram
Receiver Model	Trimble R-8, Model 3
Receiver S/N	5046455718
Antenna Height	2.000 Meters

Date (MM-DD-YYYY)	11-4-2016
RMSE Hz	0.009
RMSE Z	0.013
GPS Method	VRN

PHOTOS:





Point ID	CA54
Project No.	29178
Project Name	VT CT River Basin
State	Vermont
County	Essex
Quad	Averill Lake

	Aerial Target
X	LiDAR Ground Control
	LiDAR QC Point
	New Control
	Photo ID
	Published Control

Coordinate System
NAD83(2011)
State Plane VT
NAVD88
GEOID12B
Meters

Northing	Easting	Elevation
267586.740	563115.305	529.777

Operator	Zeke Ingram
Receiver Model	Trimble R-8, Model 3
Receiver S/N	5046455718
Antenna Height	2.000 Meters

Date (MM-DD-YYYY)	11-4-2016
RMSE Hz	0.011
RMSE Z	0.017
GPS Method	Static

PHOTOS:





Point ID	CA55
Project No.	29178
Project Name	VT CT River Basin
State	Vermont
County	Essex
Quad	Morgan Center

	Aerial Target
X	LiDAR Ground Control
	LiDAR QC Point
	New Control
	Photo ID
	Published Control

Coordinate System	
NAD83(2011)	
State Plane VT	
NAVD88	
GEOID12B	
Meters	

Northing	Easting	Elevation
267964.167	549335.036	422.293

Operator	Zeke Ingram
Receiver Model	Trimble R-8, Model 3
Receiver S/N	5046455718
Antenna Height	2.000 Meters

Date (MM-DD-YYYY)	11-4-2016
RMSE Hz	0.008
RMSE Z	0.011
GPS Method	Static

PHOTOS:





Point ID	CA56
Project No.	29178
Project Name	VT CT River Basin
State	Vermont
County	Essex
Quad	Norton Pond OE N

	Aerial Target
X	LiDAR Ground Control
	LiDAR QC Point
	New Control
	Photo ID
	Published Control

Coordinate System
NAD83(2011)
State Plane VT
NAVD88
GEOID12B
Meters

Northing	Easting	Elevation
279064.170	555834.567	391.818

Operator	Zeke Ingram
Receiver Model	Trimble R-8, Model 3
Receiver S/N	5046455718
Antenna Height	2.000 Meters

Date (MM-DD-YYYY)	11-4-2016
RMSE Hz	0.006
RMSE Z	0.010
GPS Method	Static

PHOTOS:





Point ID	CA57
Project No.	29178
Project Name	VT CT River Basin
State	Vermont
County	Essex
Quad	Monadnock Mountain

	Aerial Target
X	LiDAR Ground Control
	LiDAR QC Point
	New Control
	Photo ID
	Published Control

Coordinate System	
NAD83(2011)	
State Plane VT	
NAVD88	
GEOID12B	
Meters	

Northing	Easting	Elevation
275770.824	573509.249	381.293

Operator	Zeke Ingram
Receiver Model	Trimble R-8, Model 4
Receiver S/N	5407453971
Antenna Height	2.000 Meters

Date (MM-DD-YYYY)	11-4-2016
RMSE Hz	0.006
RMSE Z	0.012
GPS Method	Static

PHOTOS:





Bare Earth Point Log Sheets





Point ID	BE01
Project No.	29178
Project Name	VT CT River Basin
State	Vermont
County	Windham
Quad	Saxton's River

Aerial Target	
LiDAR Ground Control	
X LiDAR QC Point	
New Control	
Photo ID	
Published Control	

Coordinate System	NAD83(2011)
State Plane VT	NAVD88
GEOID12B	
Meters	

Northing	Easting	Elevation
74251.846	490914.888	255.965

Operator	Zeke Ingram
Receiver Model	Trimble R-8, Model 3
Receiver S/N	5046455718
Antenna Height	2.000 Meters

Date (MM-DD-YYYY)	11-11-2016
RMSE Hz	0.008
RMSE Z	0.011
GPS Method	VRN

PHOTOS:





Point ID	BE02
Project No.	29178
Project Name	VT CT River Basin
State	Vermont
County	Windsor
Quad	Weston

Aerial Target	
LiDAR Ground Control	
X LiDAR QC Point	
New Control	
Photo ID	
Published Control	

Coordinate System	NAD83(2011)
State Plane VT	NAVD88
GEOID12B	
Meters	

Northing	Easting	Elevation
88046.362	475998.939	406.903

Operator	Zeke Ingram
Receiver Model	Trimble R-8, Model 3
Receiver S/N	5046455718
Antenna Height	2.000 Meters

Date (MM-DD-YYYY)	11-11-2016
RMSE Hz	0.006
RMSE Z	0.010
GPS Method	VRN

PHOTOS:





Point ID	BE03
Project No.	29178
Project Name	VT CT River Basin
State	Vermont
County	Windsor
Quad	Springfield

	Aerial Target
	LiDAR Ground Control
X	LiDAR QC Point
	New Control
	Photo ID
	Published Control

Coordinate System
NAD83(2011)
State Plane VT
NAVD88
GEOID12B
Meters

Northing	Easting	Elevation
89385.664	500162.044	155.765

Operator	Zeke Ingram
Receiver Model	Trimble R-8, Model 3
Receiver S/N	5046455718
Antenna Height	2.000 Meters

Date (MM-DD-YYYY)	11-12-2016
RMSE Hz	0.010
RMSE Z	0.020
GPS Method	VRN

PHOTOS:





Point ID	BE04
Project No.	29178
Project Name	VT CT River Basin
State	Vermont
County	Windsor
Quad	Andover

	Aerial Target
	LiDAR Ground Control
X	LiDAR QC Point
	New Control
	Photo ID
	Published Control

Coordinate System
NAD83(2011)
State Plane VT
NAVD88
GEOID12B
Meters

Northing	Easting	Elevation
95849.968	482054.549	498.980

Operator	Zeke Ingram
Receiver Model	Trimble R-8, Model 3
Receiver S/N	5046455718
Antenna Height	2.000 Meters

Date (MM-DD-YYYY)	11-12-2016
RMSE Hz	0.007
RMSE Z	0.011
GPS Method	VRN

PHOTOS:





Point ID	BE05
Project No.	29178
Project Name	VT CT River Basin
State	Vermont
County	Windsor
Quad	Ludlow

Aerial Target	
LiDAR Ground Control	
X LiDAR QC Point	
New Control	
Photo ID	
Published Control	

Coordinate System	NAD83(2011)
State Plane VT	NAVD88
Geoid	GEOID12B
Units	Meters

Northing	Easting	Elevation
107194.960	483448.600	327.674

Operator	Zeke Ingram
Receiver Model	Trimble R-8, Model 3
Receiver S/N	5046455718
Antenna Height	2.000 Meters

Date (MM-DD-YYYY)	11-13-2016
RMSE Hz	0.010
RMSE Z	0.014
GPS Method	VRN

PHOTOS:





Point ID	BE06
Project No.	29178
Project Name	VT CT River Basin
State	Vermont
County	Windsor
Quad	Bethel

Aerial Target	
LiDAR Ground Control	
X LiDAR QC Point	
New Control	
Photo ID	
Published Control	

Coordinate System	NAD83(2011)
	VT SPCS
	NAVD88
	GEOID12B
	Meters

Northing	Easting	Elevation
140503.954	482981.377	216.650

Operator	Kevin Chapman
Receiver Model	Trimble R-8, Model 3
Receiver S/N	5106461067
Antenna Height	2.000 Meters

Date (MM-DD-YYYY)	11-11-2016
RMSE Hz	0.007
RMSE Z	0.012
GPS Method	VRN

PHOTOS:





Point ID	BE07
Project No.	29178
Project Name	VT CT River Basin
State	Vermont
County	Windsor
Quad	Woodstock North

Aerial Target	
LiDAR Ground Control	
X LiDAR QC Point	
New Control	
Photo ID	
Published Control	

Coordinate System	NAD83(2011)
	VT SPCS
	NAVD88
	GEOID12B
	Meters

Northing	Easting	Elevation
134748.161	490044.503	478.476

Operator	Kevin Chapman
Receiver Model	Trimble R-8, Model 3
Receiver S/N	5106461067
Antenna Height	2.000 Meters

Date (MM-DD-YYYY)	11-11-2016
RMSE Hz	0.007
RMSE Z	0.011
GPS Method	VRN

PHOTOS:





Point ID	BE08
Project No.	29178
Project Name	VT CT River Basin
State	Vermont
County	Windsor
Quad	Woodstock North

Aerial Target	
LiDAR Ground Control	
X LiDAR QC Point	
New Control	
Photo ID	
Published Control	

Coordinate System	NAD83(2011)
	VT SPCS
	NAVD88
	GEOID12B
	Meters

Northing	Easting	Elevation
125271.575	499379.101	209.258

Operator	Kevin Chapman
Receiver Model	Trimble R-8, Model 3
Receiver S/N	5106461067
Antenna Height	2.000 Meters

Date (MM-DD-YYYY)	11-12-2016
RMSE Hz	0.013
RMSE Z	0.025
GPS Method	VRN

PHOTOS:





Point ID	BE09
Project No.	29178
Project Name	VT CT River Basin
State	Vermont
County	Windsor
Quad	Bethel

Aerial Target	
LiDAR Ground Control	
X LiDAR QC Point	
New Control	
Photo ID	
Published Control	

Coordinate System	NAD83(2011)
	VT SPCS
	NAVD88
	GEOID12B
	Meters

Northing	Easting	Elevation
147993.703	488846.064	170.555

Operator	Kevin Chapman
Receiver Model	Trimble R-8, Model 3
Receiver S/N	5106461067
Antenna Height	2.000 Meters

Date (MM-DD-YYYY)	11-11-2016
RMSE Hz	0.008
RMSE Z	0.010
GPS Method	VRN

PHOTOS:





Point ID	BE10
Project No.	29178
Project Name	VT CT River Basin
State	Vermont
County	Orange
Quad	Lyme

Aerial Target	
LiDAR Ground Control	
X LiDAR QC Point	
New Control	
Photo ID	
Published Control	

Coordinate System	NAD83(2011)
	VT SPCS
	NAVD88
	GEOID12B
	Meters

Northing	Easting	Elevation
145764.579	523113.292	205.781

Operator	Kevin Chapman
Receiver Model	Trimble R-8, Model 3
Receiver S/N	5106461067
Antenna Height	2.000 Meters

Date (MM-DD-YYYY)	11-04-2016
RMSE Hz	0.006
RMSE Z	0.010
GPS Method	VRN

PHOTOS:





Point ID	BE11
Project No.	29178
Project Name	VT CT River Basin
State	Vermont
County	Orange
Quad	Randolph

	Aerial Target
	LiDAR Ground Control
X	LiDAR QC Point
	New Control
	Photo ID
	Published Control

Coordinate System
NAD83(2011)
VT SPCS
NAVD88
GEOID12B
Meters

Northing	Easting	Elevation
155877.955	487645.075	209.649

Operator	Kevin Chapman
Receiver Model	Trimble R-8, Model 3
Receiver S/N	5106461067
Antenna Height	2.000 Meters

Date (MM-DD-YYYY)	11-01-2016
RMSE Hz	0.007
RMSE Z	0.009
GPS Method	VRN

PHOTOS:





Point ID	BE12
Project No.	29178
Project Name	VT CT River Basin
State	Vermont
County	Orange
Quad	Chelsea

Aerial Target	
LiDAR Ground Control	
X LiDAR QC Point	
New Control	
Photo ID	
Published Control	

Coordinate System	NAD83(2011)
	VT SPCS
	NAVD88
	GEOID12B
	Meters

Northing	Easting	Elevation
164645.389	504154.290	244.608

Operator	Kevin Chapman
Receiver Model	Trimble R-8, Model 3
Receiver S/N	5106461067
Antenna Height	2.000 Meters

Date (MM-DD-YYYY)	11-01-2016
RMSE Hz	0.006
RMSE Z	0.008
GPS Method	Static

PHOTOS:





Point ID	BE13
Project No.	29178
Project Name	VT CT River Basin
State	Vermont
County	Orange
Quad	Randolph

	Aerial Target
	LiDAR Ground Control
X	LiDAR QC Point
	New Control
	Photo ID
	Published Control

Coordinate System
NAD83(2011)
VT SPCS
NAVD88
GEOID12B
Meters

Northing	Easting	Elevation
166286.086	487797.606	226.812

Operator	Kevin Chapman
Receiver Model	Trimble R-8, Model 3
Receiver S/N	5106461067
Antenna Height	2.000 Meters

Date (MM-DD-YYYY)	11-01-2016
RMSE Hz	0.008
RMSE Z	0.012
GPS Method	VRN

PHOTOS:





Point ID	BE15
Project No.	29178
Project Name	VT CT River Basin
State	Vermont
County	Orange
Quad	Chelsea

Aerial Target	
LiDAR Ground Control	
X LiDAR QC Point	
New Control	
Photo ID	
Published Control	

Coordinate System	NAD83(2011)
	VT SPCS
	NAVD88
	GEOID12B
	Meters

Northing	Easting	Elevation
158106.925	502742.460	190.001

Operator	Kevin Chapman
Receiver Model	Trimble R-8, Model 3
Receiver S/N	5106461067
Antenna Height	2.000 Meters

Date (MM-DD-YYYY)	11-04-2016
RMSE Hz	0.007
RMSE Z	0.013
GPS Method	VRN

PHOTOS:





Point ID	BE16
Project No.	29178
Project Name	VT CT River Basin
State	Vermont
County	Orange
Quad	Vershire

Aerial Target	
LiDAR Ground Control	
X LiDAR QC Point	
New Control	
Photo ID	
Published Control	

Coordinate System	NAD83(2011)
	VT SPCS
	NAVD88
	GEOID12B
	Meters

Northing	Easting	Elevation
156658.866	519061.959	222.985

Operator	Kevin Chapman
Receiver Model	Trimble R-8, Model 3
Receiver S/N	5106461067
Antenna Height	2.000 Meters

Date (MM-DD-YYYY)	11-01-2016
RMSE Hz	0.010
RMSE Z	0.013
GPS Method	Static

PHOTOS:





Point ID	BE17
Project No.	29178
Project Name	VT CT River Basin
State	Vermont
County	Orange
Quad	Fairlee

Aerial Target	
LiDAR Ground Control	
X LiDAR QC Point	
New Control	
Photo ID	
Published Control	

Coordinate System	NAD83(2011)
	VT SPCS
	NAVD88
	GEOID12B
	Meters

Northing	Easting	Elevation
157374.644	529529.440	131.796

Operator	Kevin Chapman
Receiver Model	Trimble R-8, Model 3
Receiver S/N	5106461067
Antenna Height	2.000 Meters

Date (MM-DD-YYYY)	11-04-2016
RMSE Hz	0.008
RMSE Z	0.010
GPS Method	VRN

PHOTOS:





Point ID	BE18
Project No.	29178
Project Name	VT CT River Basin
State	Vermont
County	Windsor
Quad	West Topsham

	Aerial Target
	LiDAR Ground Control
X	LiDAR QC Point
	New Control
	Photo ID
	Published Control

Coordinate System
NAD83(2011)
VT SPCS
NAVD88
GEOID12B
Meters

Northing	Easting	Elevation
168120.439	519141.703	250.701

Operator	Kevin Chapman
Receiver Model	Trimble R-8, Model 3
Receiver S/N	5106461067
Antenna Height	2.000 Meters

Date (MM-DD-YYYY)	11-13-2016
RMSE Hz	0.008
RMSE Z	0.013
GPS Method	Statc

PHOTOS:





Point ID	BE19
Project No.	29178
Project Name	VT CT River Basin
State	Vermont
County	Windsor
Quad	West Topsham

Aerial Target	
LiDAR Ground Control	
X LiDAR QC Point	
New Control	
Photo ID	
Published Control	

Coordinate System	NAD83(2011)
	VT SPCS
	NAVD88
	GEOID12B
	Meters

Northing	Easting	Elevation
177632.739	515771.503	294.542

Operator	Kevin Chapman
Receiver Model	Trimble R-8, Model 3
Receiver S/N	5106461067
Antenna Height	2.000 Meters

Date (MM-DD-YYYY)	11-13-2016
RMSE Hz	0.017
RMSE Z	0.015
GPS Method	Static

PHOTOS:





Point ID	BE20
Project No.	29178
Project Name	VT CT River Basin
State	Vermont
County	Orange
Quad	East Corinth

Aerial Target	
LiDAR Ground Control	
X LiDAR QC Point	
New Control	
Photo ID	
Published Control	

Coordinate System	NAD83(2011)
	VT SPCS
	NAVD88
	GEOID12B
	Meters

Northing	Easting	Elevation
174156.064	529919.670	290.845

Operator	Kevin Chapman
Receiver Model	Trimble R-8, Model 3
Receiver S/N	5106461067
Antenna Height	2.000 Meters

Date (MM-DD-YYYY)	11-02-2016
RMSE Hz	0.008
RMSE Z	0.013
GPS Method	VRN

PHOTOS:





Point ID	BE21
Project No.	29178
Project Name	VT CT River Basin
State	Vermont
County	Orange
Quad	Woodsville

Aerial Target	
LiDAR Ground Control	
X LiDAR QC Point	
New Control	
Photo ID	
Published Control	

Coordinate System	NAD83(2011)
	VT SPCS
	NAVD88
	GEOID12B
	Meters

Northing	Easting	Elevation
183847.537	533042.553	189.629

Operator	Kevin Chapman
Receiver Model	Trimble R-8, Model 3
0.012Receiver S/N	5106461067
Antenna Height	2.000 Meters

Date (MM-DD-YYYY)	11-02-2016
RMSE Hz	0.009
RMSE Z	0.012
GPS Method	VRN

PHOTOS:





Point ID	BE22
Project No.	29178
Project Name	VT CT River Basin
State	Vermont
County	Caledonia
Quad	Groton

	Aerial Target
	LiDAR Ground Control
X	LiDAR QC Point
	New Control
	Photo ID
	Published Control

Coordinate System
NAD83(2011)
VT SPCS
NAVD88
GEOID12B
Meters

Northing	Easting	Elevation
191051.998	522527.008	267.055

Operator	Kevin Chapman
Receiver Model	Trimble R-8, Model 3
Receiver S/N	5106461067
Antenna Height	2.000 Meters

Date (MM-DD-YYYY)	11-02-2016
RMSE Hz	0.007
RMSE Z	0.014
GPS Method	VRN

PHOTOS:





Point ID	BE23
Project No.	29178
Project Name	VT CT River Basin
State	Vermont
County	Caledonia
Quad	Woodsville

Aerial Target	
LiDAR Ground Control	
X LiDAR QC Point	
New Control	
Photo ID	
Published Control	

Coordinate System	NAD83(2011)
	VT SPCS
	NAVD88
	GEOID12B
	Meters

Northing	Easting	Elevation
192914.637	535436.201	159.134

Operator	Kevin Chapman
Receiver Model	Trimble R-8, Model 3
Receiver S/N	5106461067
Antenna Height	2.000 Meters

Date (MM-DD-YYYY)	11-02-2016
RMSE Hz	0.007
RMSE Z	0.009
GPS Method	VRN

PHOTOS:





Point ID	BE24
Project No.	29178
Project Name	VT CT River Basin
State	Vermont
County	Caledonia
Quad	Marshfield

Aerial Target	
LiDAR Ground Control	
X LiDAR QC Point	
New Control	
Photo ID	
Published Control	

Coordinate System	NAD83(2011)
State Plane VT	NAVD88
GEOID12B	
Meters	

Northing	Easting	Elevation
198415.660	518792.398	342.590

Operator	Kevin Chapman
Receiver Model	Trimble R-8, Model 3
Receiver S/N	5106461067
Antenna Height	2.000 Meters

Date (MM-DD-YYYY)	11-6-2016
RMSE Hz	0.011
RMSE Z	0.018
GPS Method	VRN

PHOTOS:





Point ID	BE25
Project No.	29178
Project Name	VT CT River Basin
State	Vermont
County	Caledonia
Quad	Peachem

Aerial Target	
LiDAR Ground Control	
X LiDAR QC Point	
New Control	
Photo ID	
Published Control	

Coordinate System	NAD83(2011)
	VT SPCS
	NAVD88
	GEOID12B
	Meters

Northing	Easting	Elevation
203085.135	526276.199	407.878

Operator	Kevin Chapman
Receiver Model	Trimble R-8, Model 3
Receiver S/N	5106461067
Antenna Height	2.000 Meters

Date (MM-DD-YYYY)	11-02-2016
RMSE Hz	0.007
RMSE Z	0.010
GPS Method	VRN

PHOTOS:





Point ID	BE26
Project No.	29178
Project Name	VT CT River Basin
State	Vermont
County	Caledonia
Quad	Barnet

	Aerial Target
	LiDAR Ground Control
X	LiDAR QC Point
	New Control
	Photo ID
	Published Control

Coordinate System
NAD83(2011)
VT SPCS
NAVD88
GEOID12B
Meters

Northing	Easting	Elevation
200496.258	533474.582	216.382

Operator	Kevin Chapman
Receiver Model	Trimble R-8, Model 3
Receiver S/N	5106461067
Antenna Height	2.000 Meters

Date (MM-DD-YYYY)	11-02-2016
RMSE Hz	0.007
RMSE Z	0.011
GPS Method	VRN

PHOTOS:





Point ID	BE27
Project No.	29178
Project Name	VT CT River Basin
State	Vermont
County	Caledonia
Quad	Joes Pond

Aerial Target	
LiDAR Ground Control	
X LiDAR QC Point	
New Control	
Photo ID	
Published Control	

Coordinate System	NAD83(2011)
State Plane VT	NAVD88
GEOID12B	
Meters	

Northing	Easting	Elevation
216978.589	522113.353	497.712

Operator	Zeke Ingram
Receiver Model	Trimble R-8, Model 3
Receiver S/N	5046455718
Antenna Height	2.000 Meters

Date (MM-DD-YYYY)	11-2-2016
RMSE Hz	0.007
RMSE Z	0.010
GPS Method	VRN

PHOTOS:





Point ID	BE28
Project No.	29178
Project Name	VT CT River Basin
State	Vermont
County	Caledonia
Quad	Lyndonville

Aerial Target	
LiDAR Ground Control	
X LiDAR QC Point	
New Control	
Photo ID	
Published Control	

Coordinate System	NAD83(2011)
State Plane VT	NAVD88
GEOID12B	
Meters	

Northing	Easting	Elevation
224235.998	539384.097	215.400

Operator	Zeke Ingram
Receiver Model	Trimble R-8, Model 3
Receiver S/N	5046455718
Antenna Height	2.000 Meters

Date (MM-DD-YYYY)	11-2-2016
RMSE Hz	0.006
RMSE Z	0.009
GPS Method	VRN

PHOTOS:





Point ID	BE29
Project No.	29178
Project Name	VT CT River Basin
State	Vermont
County	Essex
Quad	Miles Pond

Aerial Target	
LiDAR Ground Control	
X LiDAR QC Point	
New Control	
Photo ID	
Published Control	

Coordinate System	NAD83(2011)
State Plane VT	NAVD88
GEOID12B	
Meters	

Northing	Easting	Elevation
218893.105	551248.535	326.766

Operator	Zeke Ingram
Receiver Model	Trimble R-8, Model 3
Receiver S/N	5046455718
Antenna Height	2.000 Meters

Date (MM-DD-YYYY)	11-2-2016
RMSE Hz	0.007
RMSE Z	0.010
GPS Method	VRN

PHOTOS:





Point ID	BE30
Project No.	29178
Project Name	VT CT River Basin
State	Vermont
County	Essex
Quad	Gilman

Aerial Target	
LiDAR Ground Control	
X LiDAR QC Point	
New Control	
Photo ID	
Published Control	

Coordinate System	NAD83(2011)
State Plane VT	NAVD88
GEOID12B	
Meters	

Northing	Easting	Elevation
212951.780	562535.251	260.207

Operator	Zeke Ingram
Receiver Model	Trimble R-8, Model 3
Receiver S/N	5046455718
Antenna Height	2.000 Meters

Date (MM-DD-YYYY)	11-2-2016
RMSE Hz	0.007
RMSE Z	0.010
GPS Method	VRN

PHOTOS:





Point ID	BE31
Project No.	29178
Project Name	VT CT River Basin
State	Vermont
County	Caledonia
Quad	Stannard

	Aerial Target
	LiDAR Ground Control
X	LiDAR QC Point
	New Control
	Photo ID
	Published Control

Coordinate System
NAD83(2011)
State Plane VT
NAVD88
GEOID12B
Meters

Northing	Easting	Elevation
227259.936	529081.733	448.717

Operator	Zeke Ingram
Receiver Model	Trimble R-8, Model 3
Receiver S/N	5046455718
Antenna Height	2.000 Meters

Date (MM-DD-YYYY)	11-17-2016
RMSE Hz	0.009
RMSE Z	0.015
GPS Method	STATIC

PHOTOS:





Point ID	BE32
Project No.	29178
Project Name	VT CT River Basin
State	Vermont
County	Caledonia
Quad	St. Johnsbury

Aerial Target	
LiDAR Ground Control	
X LiDAR QC Point	
New Control	
Photo ID	
Published Control	

Coordinate System	NAD83(2011)
State Plane VT	NAVD88
GEOID12B	
Meters	

Northing	Easting	Elevation
222195.361	531969.151	365.389

Operator	Zeke Ingram
Receiver Model	Trimble R-8, Model 3
Receiver S/N	5046455718
Antenna Height	2.000 Meters

Date (MM-DD-YYYY)	11-2-2016
RMSE Hz	0.010
RMSE Z	0.014
GPS Method	VRN

PHOTOS:





Point ID	BE33
Project No.	29178
Project Name	VT CT River Basin
State	Vermont
County	Essex
Quad	Gallup Mills

Aerial Target	
LiDAR Ground Control	
X LiDAR QC Point	
New Control	
Photo ID	
Published Control	

Coordinate System	NAD83(2011)
State Plane VT	NAVD88
	GEOID12B
	Meters

Northing	Easting	Elevation
230282.180	558935.898	424.922

Operator	Kevin Chapman
Receiver Model	Trimble R-8, Model 3
Receiver S/N	5106461067
Antenna Height	2.000 Meters

Date (MM-DD-YYYY)	11-5-2016
RMSE Hz	0.008
RMSE Z	0.011
GPS Method	VRN

PHOTOS:





Point ID	BE34
Project No.	29178
Project Name	VT CT River Basin
State	Vermont
County	Essex
Quad	Groveton

Aerial Target	
LiDAR Ground Control	
X LiDAR QC Point	
New Control	
Photo ID	
Published Control	

Coordinate System	NAD83(2011)
State Plane VT	NAVD88
	GEOID12B
	Meters

Northing	Easting	Elevation
229889.543	574583.462	265.393

Operator	Zeke Ingram
Receiver Model	Trimble R-8, Model 3
Receiver S/N	5046455718
Antenna Height	2.000 Meters

Date (MM-DD-YYYY)	11-4-2016
RMSE Hz	0.008
RMSE Z	0.012
GPS Method	VRN

PHOTOS:





Point ID	BE35
Project No.	29178
Project Name	VT CT River Basin
State	Vermont
County	Essex
Quad	Gilman

Aerial Target	
LiDAR Ground Control	
X LiDAR QC Point	
New Control	
Photo ID	
Published Control	

Coordinate System	NAD83(2011)
State Plane VT	NAVD88
GEOID12B	
Meters	

Northing	Easting	Elevation
220748.496	568860.606	262.525

Operator	Zeke Ingram
Receiver Model	Trimble R-8, Model 3
Receiver S/N	5046455718
Antenna Height	2.000 Meters

Date (MM-DD-YYYY)	11-2-2016
RMSE Hz	0.006
RMSE Z	0.010
GPS Method	VRN

PHOTOS:





Point ID	BE36
Project No.	29178
Project Name	VT CT River Basin
State	Vermont
County	Essex
Quad	Groveton

Aerial Target	
LiDAR Ground Control	
X LiDAR QC Point	
New Control	
Photo ID	
Published Control	

Coordinate System	NAD83(2011)
State Plane VT	NAVD88
GEOID12B	
Meters	

Northing	Easting	Elevation
236019.364	574696.394	274.540

Operator	Zeke Ingram
Receiver Model	Trimble R-8, Model 3
Receiver S/N	5046455718
Antenna Height	2.000 Meters

Date (MM-DD-YYYY)	11-4-2016
RMSE Hz	0.008
RMSE Z	0.012
GPS Method	VRN

PHOTOS:





Point ID	BE37
Project No.	29178
Project Name	VT CT River Basin
State	Vermont
County	Essex
Quad	Bloomfield

Aerial Target	
LiDAR Ground Control	
X LiDAR QC Point	
New Control	
Photo ID	
Published Control	

Coordinate System	NAD83(2011)
State Plane VT	NAVD88
GEOID12B	
Meters	

Northing	Easting	Elevation
253132.988	559488.257	351.024

Operator	Zeke Ingram
Receiver Model	Trimble R-8, Model 3
Receiver S/N	5046455718
Antenna Height	2.000 Meters

Date (MM-DD-YYYY)	11-1-2016
RMSE Hz	0.008
RMSE Z	0.014
GPS Method	VRN

PHOTOS:





Point ID	BE38
Project No.	29178
Project Name	VT CT River Basin
State	Vermont
County	Essex
Quad	Tinkerville

	Aerial Target
	LiDAR Ground Control
X	LiDAR QC Point
	New Control
	Photo ID
	Published Control

Coordinate System
NAD83(2011)
State Plane VT
NAVD88
GEOID12B
Meters

Northing	Easting	Elevation
262578.090	574432.330	321.868

Operator	Zeke Ingram
Receiver Model	Trimble R-8, Model 3
Receiver S/N	5046455718
Antenna Height	2.000 Meters

Date (MM-DD-YYYY)	11-4-2016
RMSE Hz	0.009
RMSE Z	0.013
GPS Method	VRN

PHOTOS:





Point ID	BE39
Project No.	29178
Project Name	VT CT River Basin
State	Vermont
County	Essex
Quad	Averill Lake

Aerial Target	
LiDAR Ground Control	
X LiDAR QC Point	
New Control	
Photo ID	
Published Control	

Coordinate System	NAD83(2011)
State Plane VT	NAVD88
GEOID12B	
Meters	

Northing	Easting	Elevation
267646.731	563153.863	528.027

Operator	Zeke Ingram
Receiver Model	Trimble R-8, Model 4
Receiver S/N	5407453971
Antenna Height	2.000 Meters

Date (MM-DD-YYYY)	11-4-2016
RMSE Hz	0.009
RMSE Z	0.013
GPS Method	Static

PHOTOS:





Point ID	BE40
Project No.	29178
Project Name	VT CT River Basin
State	Vermont
County	Essex
Quad	Norton Pond OE N

Aerial Target	
LiDAR Ground Control	
X LiDAR QC Point	
New Control	
Photo ID	
Published Control	

Coordinate System	NAD83(2011)
State Plane VT	NAVD88
GEOID12B	
Meters	

Northing	Easting	Elevation
279047.928	555805.350	391.889

Operator	Zeke Ingram
Receiver Model	Trimble R-8, Model 4
Receiver S/N	5407453971
Antenna Height	2.000 Meters

Date (MM-DD-YYYY)	11-4-2016
RMSE Hz	0.006
RMSE Z	0.010
GPS Method	Static

PHOTOS:





Point ID	BE41
Project No.	29178
Project Name	VT CT River Basin
State	Vermont
County	Windsor
Quad	Cavendish

Aerial Target	
LiDAR Ground Control	
X LiDAR QC Point	
New Control	
Photo ID	
Published Control	

Coordinate System	NAD83(2011)
	VT SPCS
	NAVD88
	GEOID12B
	Meters

Northing	Easting	Elevation
106139.051	498721.428	234.270

Operator	Kevin Chapman
Receiver Model	Trimble R-8, Model 3
Receiver S/N	5106461067
Antenna Height	2.000 Meters

Date (MM-DD-YYYY)	11-12-2016
RMSE Hz	0.006
RMSE Z	0.009
GPS Method	VRN

PHOTOS:





Point ID	BE42
Project No.	29178
Project Name	VT CT River Basin
State	Vermont
County	Windham
Quad	Londonderry

	Aerial Target
	LiDAR Ground Control
X	LiDAR QC Point
	New Control
	Photo ID
	Published Control

Coordinate System
NAD83(2011)
State Plane VT
NAVD88
GEOID12B
Meters

Northing	Easting	Elevation
71667.938	472088.591	361.295

Operator	Zeke Ingram
Receiver Model	Trimble R-8, Model 3
Receiver S/N	5046455718
Antenna Height	2.000 Meters

Date (MM-DD-YYYY)	11-11-2016
RMSE Hz	0.007
RMSE Z	0.012
GPS Method	VRN

PHOTOS:





Point ID	BE43
Project No.	29178
Project Name	VT CT River Basin
State	Vermont
County	Caledonia
Quad	West Burke

Aerial Target	
LiDAR Ground Control	
X LiDAR QC Point	
New Control	
Photo ID	
Published Control	

Coordinate System	NAD83(2011)
State Plane VT	NAVD88
	GEOID12B
	Meters

Northing	Easting	Elevation
243236.048	543485.694	535.429

Operator	Zeke Ingram
Receiver Model	Trimble R-8, Model 3
Receiver S/N	5046455718
Antenna Height	2.000 Meters

Date (MM-DD-YYYY)	11-1-2016
RMSE Hz	0.010
RMSE Z	0.014
GPS Method	VRN

PHOTOS:





Point ID	BE44
Project No.	29178
Project Name	VT CT River Basin
State	Vermont
County	Orange
Quad	South Strafford

Aerial Target	
LiDAR Ground Control	
X LiDAR QC Point	
New Control	
Photo ID	
Published Control	

Coordinate System	NAD83(2011)
	VT SPCS
	NAVD88
	GEOID12B
	Meters

Northing	Easting	Elevation
148303.991	511051.744	270.371

Operator	Kevin Chapman
Receiver Model	Trimble R-8, Model 3
Receiver S/N	5106461067
Antenna Height	2.000 Meters

Date (MM-DD-YYYY)	11-04-2016
RMSE Hz	0.010
RMSE Z	0.015
GPS Method	VRN

PHOTOS:





Point ID	BE45
Project No.	29178
Project Name	VT CT River Basin
State	Vermont
County	Orange
Quad	Brookfield

Aerial Target	
LiDAR Ground Control	
X LiDAR QC Point	
New Control	
Photo ID	
Published Control	

Coordinate System	NAD83(2011)
	VT SPCS
	NAVD88
	GEOID12B
	Meters

Northing	Easting	Elevation
171139.379	494461.643	220.612

Operator	Kevin Chapman
Receiver Model	Trimble R-8, Model 3
Receiver S/N	5106461067
Antenna Height	2.000 Meters

Date (MM-DD-YYYY)	11-01-2016
RMSE Hz	0.009
RMSE Z	0.015
GPS Method	VRN

PHOTOS:





Point ID	BE46
Project No.	29178
Project Name	VT CT River Basin
State	Vermont
County	Essex
Quad	Island Pond

Aerial Target	
LiDAR Ground Control	
X LiDAR QC Point	
New Control	
Photo ID	
Published Control	

Coordinate System	NAD83(2011)
State Plane VT	NAVD88
GEOID12B	
Meters	

Northing	Easting	Elevation
255442.797	546576.020	356.331

Operator	Zeke Ingram
Receiver Model	Trimble R-8, Model 3
Receiver S/N	5046455718
Antenna Height	2.000 Meters

Date (MM-DD-YYYY)	11-1-2016
RMSE Hz	0.008
RMSE Z	0.011
GPS Method	VRN

PHOTOS:





Point ID	BE47
Project No.	29178
Project Name	VT CT River Basin
State	Vermont
County	Windsor
Quad	Quechee

	Aerial Target
	LiDAR Ground Control
X	LiDAR QC Point
	New Control
	Photo ID
	Published Control

Coordinate System
NAD83(2011)
VT SPCS
NAVD88
GEOID12B
Meters

Northing	Easting	Elevation
137831.781	504879.610	129.603

Operator	Kevin Chapman
Receiver Model	Trimble R-8, Model 3
Receiver S/N	5106461067
Antenna Height	2.000 Meters

Date (MM-DD-YYYY)	11-11-2016
RMSE Hz	0.006
RMSE Z	0.009
GPS Method	VRN

PHOTOS:





Point ID	BE48
Project No.	29178
Project Name	VT CT River Basin
State	Vermont
County	Essex
Quad	Spectacle Pond

Aerial Target	
LiDAR Ground Control	
X LiDAR QC Point	
New Control	
Photo ID	
Published Control	

Coordinate System	NAD83(2011)
State Plane VT	NAVD88
GEOID12B	
Meters	

Northing	Easting	Elevation
262165.185	554648.390	471.329

Operator	Zeke Ingram
Receiver Model	Trimble R-8, Model 3
Receiver S/N	5046455718
Antenna Height	2.000 Meters

Date (MM-DD-YYYY)	11-1-2016
RMSE Hz	0.013
RMSE Z	0.018
GPS Method	Static

PHOTOS:





Point ID	BE49
Project No.	29178
Project Name	VT CT River Basin
State	Vermont
County	Essex
Quad	Monadnock Mountain

Aerial Target	
LiDAR Ground Control	
X LiDAR QC Point	
New Control	
Photo ID	
Published Control	

Coordinate System	NAD83(2011)
State Plane VT	NAVD88
GEOID12B	
Meters	

Northing	Easting	Elevation
275695.786	573484.363	382.296

Operator	Zeke Ingram
Receiver Model	Trimble R-8, Model 3
Receiver S/N	5046455718
Antenna Height	2.000 Meters

Date (MM-DD-YYYY)	11-4-2016
RMSE Hz	0.006
RMSE Z	0.012
GPS Method	Static

PHOTOS:





Point ID	BE50
Project No.	29178
Project Name	VT CT River Basin
State	Vermont
County	Caledonia
Quad	Lower Waterford

	Aerial Target
	LiDAR Ground Control
X	LiDAR QC Point
	New Control
	Photo ID
	Published Control

Coordinate System	NAD83(2011)
	State Plane VT
	NAVD88
	GEOID12B
	Meters

Northing	Easting	Elevation
204648.084	544028.727	203.990

Operator	Zeke Ingram
Receiver Model	Trimble R-8, Model 3
Receiver S/N	5046455718
Antenna Height	2.000 Meters

Date (MM-DD-YYYY)	11-2-2016
RMSE Hz	0.007
RMSE Z	0.013
GPS Method	VRN

PHOTOS:





Point ID	BE51
Project No.	29178
Project Name	VT CT River Basin
State	Vermont
County	Windsor
Quad	Andover

Aerial Target	
LiDAR Ground Control	
X LiDAR QC Point	
New Control	
Photo ID	
Published Control	

Coordinate System	NAD83(2011)
State Plane VT	NAVD88
GEOID12B	
Meters	

Northing	Easting	Elevation
84268.185	483173.283	336.936

Operator	Zeke Ingram
Receiver Model	Trimble R-8, Model 3
Receiver S/N	5046455718
Antenna Height	2.000 Meters

Date (MM-DD-YYYY)	11-11-2016
RMSE Hz	0.009
RMSE Z	0.012
GPS Method	STATIC

PHOTOS:





Urban Area Point Log Sheets



Point ID	UA01
Project No.	29178
Project Name	VT CT River Basin
State	Vermont
County	Windham
Quad	Windham

	Aerial Target
	LiDAR Ground Control
X	LiDAR QC Point
	New Control
	Photo ID
	Published Control

Coordinate System
NAD83(2011)
State Plane VT
NAVD88
GEOID12B
Meters

Northing	Easting	Elevation
75618.566	481627.636	601.461

Operator	Zeke Ingram
Receiver Model	Trimble R-8, Model 3
Receiver S/N	5046455718
Antenna Height	2.000 Meters

Date (MM-DD-YYYY)	11-11-2016
RMSE Hz	0.010
RMSE Z	0.015
GPS Method	VRN

PHOTOS:





Point ID	UA02
Project No.	29178
Project Name	VT CT River Basin
State	Vermont
County	Windsor
Quad	Chester

	Aerial Target
	LiDAR Ground Control
X	LiDAR QC Point
	New Control
	Photo ID
	Published Control

Coordinate System	
NAD83(2011)	
State Plane VT	
NAVD88	
GEOID12B	
Meters	

Northing	Easting	Elevation
84446.438	492698.516	180.085

Operator	Zeke Ingram
Receiver Model	Trimble R-8, Model 3
Receiver S/N	5046455718
Antenna Height	2.000 Meters

Date (MM-DD-YYYY)	11-11-2016
RMSE Hz	0.007
RMSE Z	0.011
GPS Method	VRN

PHOTOS:





Point ID	UA03
Project No.	29178
Project Name	VT CT River Basin
State	Vermont
County	Windsor
Quad	Cavendish

Aerial Target	
LiDAR Ground Control	
X LiDAR QC Point	
New Control	
Photo ID	
Published Control	

Coordinate System	NAD83(2011)
State Plane VT	NAVD88
GEOID12B	
Meters	

Northing	Easting	Elevation
99984.522	498844.891	186.992

Operator	Zeke Ingram
Receiver Model	Trimble R-8, Model 3
Receiver S/N	5046455718
Antenna Height	2.000 Meters

Date (MM-DD-YYYY)	11-13-2016
RMSE Hz	0.007
RMSE Z	0.010
GPS Method	VRN

PHOTOS:





Point ID	UA04
Project No.	29178
Project Name	VT CT River Basin
State	Vermont
County	Windsor
Quad	Chester

	Aerial Target
	LiDAR Ground Control
X	LiDAR QC Point
	New Control
	Photo ID
	Published Control

Coordinate System
NAD83(2011)
State Plane VT
NAVD88
GEOID12B
Meters

Northing	Easting	Elevation
91596.635	491356.381	219.489

Operator	Zeke Ingram
Receiver Model	Trimble R-8, Model 3
Receiver S/N	5046455718
Antenna Height	2.000 Meters

Date (MM-DD-YYYY)	11-12-2016
RMSE Hz	0.010
RMSE Z	0.015
GPS Method	VRN

PHOTOS:





Point ID	UA05
Project No.	29178
Project Name	VT CT River Basin
State	Vermont
County	Windsor
Quad	Cavendish

Aerial Target	
LiDAR Ground Control	
X LiDAR QC Point	
New Control	
Photo ID	
Published Control	

Coordinate System	NAD83(2011)
State Plane VT	NAVD88
GEOID12B	
Meters	

Northing	Easting	Elevation
108883.995	496091.732	281.955

Operator	Zeke Ingram
Receiver Model	Trimble R-8, Model 3
Receiver S/N	5046455718
Antenna Height	2.000 Meters

Date (MM-DD-YYYY)	11-13-2016
RMSE Hz	0.011
RMSE Z	0.020
GPS Method	VRN

PHOTOS:





Point ID	UA06
Project No.	29178
Project Name	VT CT River Basin
State	Vermont
County	Windsor
Quad	Hanover

Aerial Target	
LiDAR Ground Control	
X LiDAR QC Point	
New Control	
Photo ID	
Published Control	

Coordinate System	NAD83(2011)
	VT SPCS
	NAVD88
	GEOID12B
	Meters

Northing	Easting	Elevation
126145.505	512368.120	176.958

Operator	Kevin Chapman
Receiver Model	Trimble R-8, Model 3
Receiver S/N	5106461067
Antenna Height	2.000 Meters

Date (MM-DD-YYYY)	11-12-2016
RMSE Hz	0.008
RMSE Z	0.013
GPS Method	VRN

PHOTOS:





Point ID	UA07
Project No.	29178
Project Name	VT CT River Basin
State	Vermont
County	Windsor
Quad	Sharon

Aerial Target	
LiDAR Ground Control	
X LiDAR QC Point	
New Control	
Photo ID	
Published Control	

Coordinate System	NAD83(2011)
	VT SPCS
	NAVD88
	GEOID12B
	Meters

Northing	Easting	Elevation
142671.104	503691.549	150.611

Operator	Kevin Chapman
Receiver Model	Trimble R-8, Model 3
Receiver S/N	5106461067
Antenna Height	2.000 Meters

Date (MM-DD-YYYY)	11-11-2016
RMSE Hz	0.008
RMSE Z	0.014
GPS Method	VRN

PHOTOS:





Point ID	UA08
Project No.	29178
Project Name	VT CT River Basin
State	Vermont
County	Orange
Quad	South Strafford

Aerial Target	
LiDAR Ground Control	
X LiDAR QC Point	
New Control	
Photo ID	
Published Control	

Coordinate System	NAD83(2011)
	VT SPCS
	NAVD88
	GEOID12B
	Meters

Northing	Easting	Elevation
148326.038	511330.365	268.384

Operator	Kevin Chapman
Receiver Model	Trimble R-8, Model 3
Receiver S/N	5106461067
Antenna Height	2.000 Meters

Date (MM-DD-YYYY)	11-04-2016
RMSE Hz	0.007
RMSE Z	0.009
GPS Method	Static

PHOTOS:





Point ID	UA09
Project No.	29178
Project Name	VT CT River Basin
State	Vermont
County	Essex
Quad	Island Pond

Aerial Target	
LiDAR Ground Control	
X LiDAR QC Point	
New Control	
Photo ID	
Published Control	

Coordinate System	NAD83(2011)
State Plane VT	NAVD88
GEOID12B	
Meters	

Northing	Easting	Elevation
257599.837	549459.141	359.527

Operator	Zeke Ingram
Receiver Model	Trimble R-8, Model 3
Receiver S/N	5046455718
Antenna Height	2.000 Meters

Date (MM-DD-YYYY)	11-1-2016
RMSE Hz	0.014
RMSE Z	0.022
GPS Method	VRN

PHOTOS:





Point ID	UA10
Project No.	29178
Project Name	VT CT River Basin
State	Vermont
County	Windsor
Quad	South Royalton

Aerial Target	
LiDAR Ground Control	
X LiDAR QC Point	
New Control	
Photo ID	
Published Control	

Coordinate System	NAD83(2011)
	VT SPCS
	NAVD88
	GEOID12B
	Meters

Northing	Easting	Elevation
147513.676	494077.189	153.238

Operator	Kevin Chapman
Receiver Model	Trimble R-8, Model 3
Receiver S/N	5106461067
Antenna Height	2.000 Meters

Date (MM-DD-YYYY)	11-11-2016
RMSE Hz	0.007
RMSE Z	0.011
GPS Method	VRN

PHOTOS:





Point ID	UA11
Project No.	29178
Project Name	VT CT River Basin
State	Vermont
County	Orange
Quad	Piermont

Aerial Target	
LiDAR Ground Control	
X LiDAR QC Point	
New Control	
Photo ID	
Published Control	

Coordinate System	NAD83(2011)
	VT SPCS
	NAVD88
	GEOID12B
	Meters

Northing	Easting	Elevation
164739.962	530299.266	138.488

Operator	Kevin Chapman
Receiver Model	Trimble R-8, Model 3
Receiver S/N	5106461067
Antenna Height	2.000 Meters

Date (MM-DD-YYYY)	11-04-2016
RMSE Hz	0.006
RMSE Z	0.009
GPS Method	VRN

PHOTOS:





Point ID	UA12
Project No.	29178
Project Name	VT CT River Basin
State	Vermont
County	Orange
Quad	Woodsville

Aerial Target	
LiDAR Ground Control	
X LiDAR QC Point	
New Control	
Photo ID	
Published Control	

Coordinate System	NAD83(2011)
	VT SPCS
	NAVD88
	GEOID12B
	Meters

Northing	Easting	Elevation
183789.281	536260.280	128.332

Operator	Kevin Chapman
Receiver Model	Trimble R-8, Model 3
Receiver S/N	5106461067
Antenna Height	2.000 Meters

Date (MM-DD-YYYY)	11-02-2016
RMSE Hz	0.008
RMSE Z	0.012
GPS Method	VRN

PHOTOS:





Point ID	UA13
Project No.	29178
Project Name	VT CT River Basin
State	Vermont
County	Caledonia
Quad	Barnet

Aerial Target	
LiDAR Ground Control	
X LiDAR QC Point	
New Control	
Photo ID	
Published Control	

Coordinate System	NAD83(2011)
	VT SPCS
	NAVD88
	GEOID12B
	Meters

Northing	Easting	Elevation
199714.985	535948.992	168.791

Operator	Kevin Chapman
Receiver Model	Trimble R-8, Model 3
Receiver S/N	5106461067
Antenna Height	2.000 Meters

Date (MM-DD-YYYY)	11-02-2016
RMSE Hz	0.007
RMSE Z	0.010
GPS Method	VRN

PHOTOS:





Point ID	UA14
Project No.	29178
Project Name	VT CT River Basin
State	Vermont
County	Caledonia
Quad	Saint Johnsbury

Aerial Target	
LiDAR Ground Control	
X LiDAR QC Point	
New Control	
Photo ID	
Published Control	

Coordinate System	NAD83(2011)
State Plane VT	NAVD88
GEOID12B	
Meters	

Northing	Easting	Elevation
213414.152	538512.925	184.862

Operator	Zeke Ingram
Receiver Model	Trimble R-8, Model 3
Receiver S/N	5046455718
Antenna Height	2.000 Meters

Date (MM-DD-YYYY)	11-2-2016
RMSE Hz	0.007
RMSE Z	0.011
GPS Method	VRN

PHOTOS:





Point ID	UA15
Project No.	29178
Project Name	VT CT River Basin
State	Vermont
County	Caledonia
Quad	Lyndonville

Aerial Target	
LiDAR Ground Control	
X LiDAR QC Point	
New Control	
Photo ID	
Published Control	

Coordinate System	NAD83(2011)
State Plane VT	NAVD88
	GEOID12B
	Meters

Northing	Easting	Elevation
226617.476	539627.652	217.751

Operator	Zeke Ingram
Receiver Model	Trimble R-8, Model 3
Receiver S/N	5046455718
Antenna Height	2.000 Meters

Date (MM-DD-YYYY)	11-2-2016
RMSE Hz	0.006
RMSE Z	0.010
GPS Method	VRN

PHOTOS:





Point ID	UA16
Project No.	29178
Project Name	VT CT River Basin
State	Vermont
County	Essex
Quad	Monadnock Mountain

Aerial Target	
LiDAR Ground Control	
X LiDAR QC Point	
New Control	
Photo ID	
Published Control	

Coordinate System	NAD83(2011)
State Plane VT	NAVD88
	GEOID12B
	Meters

Northing	Easting	Elevation
277760.698	575906.101	319.621

Operator	Zeke Ingram
Receiver Model	Trimble R-8, Model 3
Receiver S/N	5046455718
Antenna Height	2.000 Meters

Date (MM-DD-YYYY)	11-4-2016
RMSE Hz	0.014
RMSE Z	0.022
GPS Method	Static

PHOTOS:





Point ID	UA17
Project No.	29178
Project Name	VT CT River Basin
State	Vermont
County	Caledonia
Quad	Joes Pond

Aerial Target	
LiDAR Ground Control	
X LiDAR QC Point	
New Control	
Photo ID	
Published Control	

Coordinate System	NAD83(2011)
State Plane VT	NAVD88
GEOID12B	
Meters	

Northing	Easting	Elevation
212065.139	524399.309	475.012

Operator	Zeke Ingram
Receiver Model	Trimble R-8, Model 3
Receiver S/N	5046455718
Antenna Height	2.000 Meters

Date (MM-DD-YYYY)	11-2-2016
RMSE Hz	0.008
RMSE Z	0.012
GPS Method	VRN

PHOTOS:





Point ID	UA18
Project No.	29178
Project Name	VT CT River Basin
State	Vermont
County	Windsor
Quad	Ludlow

Aerial Target	
LiDAR Ground Control	
X LiDAR QC Point	
New Control	
Photo ID	
Published Control	

Coordinate System	NAD83(2011)
State Plane VT	NAVD88
	GEOID12B
	Meters

Northing	Easting	Elevation
99623.609	483621.684	305.500

Operator	Zeke Ingram
Receiver Model	Trimble R-8, Model 3
Receiver S/N	5046455718
Antenna Height	2.000 Meters

Date (MM-DD-YYYY)	11-12-2016
RMSE Hz	0.007
RMSE Z	0.011
GPS Method	VRN

PHOTOS:





Point ID	UA19
Project No.	29178
Project Name	VT CT River Basin
State	Vermont
County	Windham
Quad	Londonderry

	Aerial Target
	LiDAR Ground Control
X	LiDAR QC Point
	New Control
	Photo ID
	Published Control

Coordinate System
NAD83(2011)
State Plane VT
NAVD88
GEOID12B
Meters

Northing	Easting	Elevation
80874.822	474343.886	344.507

Operator	Zeke Ingram
Receiver Model	Trimble R-8, Model 3
Receiver S/N	5046455718
Antenna Height	2.000 Meters

Date (MM-DD-YYYY)	11-11-2016
RMSE Hz	0.009
RMSE Z	0.015
GPS Method	VRN

PHOTOS:





Point ID	UA20
Project No.	29178
Project Name	VT CT River Basin
State	Vermont
County	Windsor
Quad	Springfield

Aerial Target	
LiDAR Ground Control	
X LiDAR QC Point	
New Control	
Photo ID	
Published Control	

Coordinate System	NAD83(2011)
State Plane VT	NAVD88
	GEOID12B
	Meters

Northing	Easting	Elevation
85048.705	505100.515	97.938

Operator	Zeke Ingram
Receiver Model	Trimble R-8, Model 3
Receiver S/N	5046455718
Antenna Height	2.000 Meters

Date (MM-DD-YYYY)	11-12-2016
RMSE Hz	0.008
RMSE Z	0.014
GPS Method	VRN

PHOTOS:





Point ID	UA21
Project No.	29178
Project Name	VT CT River Basin
State	Vermont
County	Windsor
Quad	Plymouth

	Aerial Target
	LiDAR Ground Control
X	LiDAR QC Point
	New Control
	Photo ID
	Published Control

Coordinate System
NAD83(2011)
VT SPCS
NAVD88
GEOID12B
Meters

Northing	Easting	Elevation
120856.621	487410.257	258.538

Operator	Kevin Chapman
Receiver Model	Trimble R-8, Model 3
Receiver S/N	5106461067
Antenna Height	2.000 Meters

Date (MM-DD-YYYY)	11-12-2016
RMSE Hz	0.006
RMSE Z	0.011
GPS Method	VRN

PHOTOS:





Point ID	UA22
Project No.	29178
Project Name	VT CT River Basin
State	Vermont
County	Windsor
Quad	Windsor

Aerial Target	
LiDAR Ground Control	
X LiDAR QC Point	
New Control	
Photo ID	
Published Control	

Coordinate System	NAD83(2011)
	VT SPCS
	NAVD88
	GEOID12B
	Meters

Northing	Easting	Elevation
107522.717	502343.326	206.722

Operator	Kevin Chapman
Receiver Model	Trimble R-8, Model 3
Receiver S/N	5106461067
Antenna Height	2.000 Meters

Date (MM-DD-YYYY)	11-12-2016
RMSE Hz	0.007
RMSE Z	0.010
GPS Method	VRN

PHOTOS:





Point ID	UA23
Project No.	29178
Project Name	VT CT River Basin
State	Vermont
County	Windsor
Quad	Ludlow

Aerial Target	
LiDAR Ground Control	
X LiDAR QC Point	
New Control	
Photo ID	
Published Control	

Coordinate System	NAD83(2011)
State Plane VT	NAVD88
	GEOID12B
	Meters

Northing	Easting	Elevation
97790.150	488485.924	283.067

Operator	Zeke Ingram
Receiver Model	Trimble R-8, Model 3
Receiver S/N	5046455718
Antenna Height	2.000 Meters

Date (MM-DD-YYYY)	11-12-2016
RMSE Hz	0.007
RMSE Z	0.010
GPS Method	VRN

PHOTOS:





Point ID	UA24
Project No.	29178
Project Name	VT CT River Basin
State	Vermont
County	Windsor
Quad	Plymouth

Aerial Target	
LiDAR Ground Control	
X LiDAR QC Point	
New Control	
Photo ID	
Published Control	

Coordinate System	NAD83(2011)
	VT SPCS
	NAVD88
	GEOID12B
	Meters

Northing	Easting	Elevation
115076.732	482087.401	431.231

Operator	Kevin Chapman
Receiver Model	Trimble R-8, Model 3
Receiver S/N	5106461067
Antenna Height	2.000 Meters

Date (MM-DD-YYYY)	11-12-2016
RMSE Hz	0.007
RMSE Z	0.010
GPS Method	VRN

PHOTOS:





Point ID	UA25
Project No.	29178
Project Name	VT CT River Basin
State	Vermont
County	Orange
Quad	Randolph Center

Aerial Target	
LiDAR Ground Control	
X LiDAR QC Point	
New Control	
Photo ID	
Published Control	

Coordinate System	NAD83(2011)
	VT SPCS
	NAVD88
	GEOID12B
	Meters

Northing	Easting	Elevation
159703.291	491478.097	419.757

Operator	Kevin Chapman
Receiver Model	Trimble R-8, Model 3
Receiver S/N	5106461067
Antenna Height	2.000 Meters

Date (MM-DD-YYYY)	11-04-2016
RMSE Hz	0.008
RMSE Z	0.012
GPS Method	VRN

PHOTOS:





Point ID	UA26
Project No.	29178
Project Name	VT CT River Basin
State	Vermont
County	Orange
Quad	Newbury

Aerial Target	
LiDAR Ground Control	
X LiDAR QC Point	
New Control	
Photo ID	
Published Control	

Coordinate System	NAD83(2011)
	VT SPCS
	NAVD88
	GEOID12B
	Meters

Northing	Easting	Elevation
175523.734	535415.497	143.984

Operator	Kevin Chapman
Receiver Model	Trimble R-8, Model 3
Receiver S/N	5106461067
Antenna Height	2.000 Meters

Date (MM-DD-YYYY)	11-02-2016
RMSE Hz	0.008
RMSE Z	0.014
GPS Method	VRN

PHOTOS:





Point ID	UA27
Project No.	29178
Project Name	VT CT River Basin
State	Vermont
County	Essex
Quad	Bloomfield

Aerial Target	
LiDAR Ground Control	
X LiDAR QC Point	
New Control	
Photo ID	
Published Control	

Coordinate System	NAD83(2011)
State Plane VT	NAVD88
	GEOID12B
	Meters

Northing	Easting	Elevation
250534.648	568950.176	276.727

Operator	Zeke Ingram
Receiver Model	Trimble R-8, Model 3
Receiver S/N	5046455718
Antenna Height	2.000 Meters

Date (MM-DD-YYYY)	11-1-2016
RMSE Hz	0.009
RMSE Z	0.013
GPS Method	Static

PHOTOS:





Point ID	UA28
Project No.	29178
Project Name	VT CT River Basin
State	Vermont
County	Caledonia
Quad	Groton

	Aerial Target
	LiDAR Ground Control
X	LiDAR QC Point
	New Control
	Photo ID
	Published Control

Coordinate System
NAD83(2011)
VT SPCS
NAVD88
GEOID12B
Meters

Northing	Easting	Elevation
190054.647	524334.032	243.563

Operator	Kevin Chapman
Receiver Model	Trimble R-8, Model 3
Receiver S/N	5106461067
Antenna Height	2.000 Meters

Date (MM-DD-YYYY)	11-02-2016
RMSE Hz	0.008
RMSE Z	0.013
GPS Method	VRN

PHOTOS:





Point ID	UA29
Project No.	29178
Project Name	VT CT River Basin
State	Vermont
County	Orange
Quad	East Corinth

Aerial Target	
LiDAR Ground Control	
X LiDAR QC Point	
New Control	
Photo ID	
Published Control	

Coordinate System	NAD83(2011)
	VT SPCS
	NAVD88
	GEOID12B
	Meters

Northing	Easting	Elevation
173853.596	522268.756	215.094

Operator	Kevin Chapman
Receiver Model	Trimble R-8, Model 3
Receiver S/N	5106461067
Antenna Height	2.000 Meters

Date (MM-DD-YYYY)	11-02-2016
RMSE Hz	0.007
RMSE Z	0.011
GPS Method	VRN

PHOTOS:





Point ID	UA30
Project No.	29178
Project Name	VT CT River Basin
State	Vermont
County	Windsor
Quad	Hartland

Aerial Target	
LiDAR Ground Control	
X LiDAR QC Point	
New Control	
Photo ID	
Published Control	

Coordinate System	NAD83(2011)
	VT SPCS
	NAVD88
	GEOID12B
	Meters

Northing	Easting	Elevation
111745.657	508080.730	147.225

Operator	Kevin Chapman
Receiver Model	Trimble R-8, Model 3
Receiver S/N	5106461067
Antenna Height	2.000 Meters

Date (MM-DD-YYYY)	11-12-2016
RMSE Hz	0.006
RMSE Z	0.009
GPS Method	VRN

PHOTOS:





Point ID	UA31
Project No.	29178
Project Name	VT CT River Basin
State	Vermont
County	Windsor
Quad	Quechee

Aerial Target	
LiDAR Ground Control	
X LiDAR QC Point	
New Control	
Photo ID	
Published Control	

Coordinate System	NAD83(2011)
	VT SPCS
	NAVD88
	GEOID12B
	Meters

Northing	Easting	Elevation
130301.843	509566.594	125.447

Operator	Kevin Chapman
Receiver Model	Trimble R-8, Model 3
Receiver S/N	5106461067
Antenna Height	2.000 Meters

Date (MM-DD-YYYY)	11-12-2016
RMSE Hz	0.006
RMSE Z	0.009
GPS Method	VRN

PHOTOS:





Point ID	UA32
Project No.	29178
Project Name	VT CT River Basin
State	Vermont
County	Windsor
Quad	Chester

Aerial Target	
LiDAR Ground Control	
X LiDAR QC Point	
New Control	
Photo ID	
Published Control	

Coordinate System	NAD83(2011)
State Plane VT	NAVD88
GEOID12B	
Meters	

Northing	Easting	Elevation
92425.126	498649.304	140.333

Operator	Zeke Ingram
Receiver Model	Trimble R-8, Model 3
Receiver S/N	5046455718
Antenna Height	2.000 Meters

Date (MM-DD-YYYY)	11-12-2016
RMSE Hz	0.006
RMSE Z	0.009
GPS Method	VRN

PHOTOS:





Point ID	UA33
Project No.	29178
Project Name	VT CT River Basin
State	Vermont
County	Caledonia
Quad	West Burke

Aerial Target	
LiDAR Ground Control	
X LiDAR QC Point	
New Control	
Photo ID	
Published Control	

Coordinate System	NAD83(2011)
State Plane VT	NAVD88
Geoid	GEOID12B
Units	Meters

Northing	Easting	Elevation
238523.816	541327.039	291.339

Operator	Zeke Ingram
Receiver Model	Trimble R-8, Model 3
Receiver S/N	5046455718
Antenna Height	2.000 Meters

Date (MM-DD-YYYY)	11-1-2016
RMSE Hz	0.008
RMSE Z	0.010
GPS Method	VRN

PHOTOS:





Point ID	UA34
Project No.	29178
Project Name	VT CT River Basin
State	Vermont
County	Caledonia
Quad	Lyndonville

Aerial Target	
LiDAR Ground Control	
X LiDAR QC Point	
New Control	
Photo ID	
Published Control	

Coordinate System	NAD83(2011)
State Plane VT	NAVD88
	GEOID12B
	Meters

Northing	Easting	Elevation
233585.977	530623.142	274.764

Operator	Zeke Ingram
Receiver Model	Trimble R-8, Model 3
Receiver S/N	5046455718
Antenna Height	2.000 Meters

Date (MM-DD-YYYY)	11-2-2016
RMSE Hz	0.008
RMSE Z	0.011
GPS Method	VRN

PHOTOS:





Tall Weeds Point Log Sheets



Point ID	TW01
Project No.	29178
Project Name	VT CT River Basin
State	Vermont
County	Windsor
Quad	Andover

Aerial Target	
LiDAR Ground Control	
X LiDAR QC Point	
New Control	
Photo ID	
Published Control	

Coordinate System	NAD83(2011)
State Plane VT	NAVD88
GEOID12B	
Meters	

Northing	Easting	Elevation
94676.026	481642.785	531.892

Operator	Zeke Ingram
Receiver Model	Trimble R-8, Model 3
Receiver S/N	5046455718
Antenna Height	2.000 Meters

Date (MM-DD-YYYY)	11-12-2016
RMSE Hz	0.008
RMSE Z	0.010
GPS Method	VRN

PHOTOS:





Point ID	TW02
Project No.	29178
Project Name	VT CT River Basin
State	Vermont
County	Caledonia
Quad	Saint Johnsbury

Aerial Target	
LiDAR Ground Control	
X LiDAR QC Point	
New Control	
Photo ID	
Published Control	

Coordinate System	NAD83(2011)
State Plane VT	NAVD88
GEOID12B	
Meters	

Northing	Easting	Elevation
222243.007	532154.816	375.814

Operator	Zeke Ingram
Receiver Model	Trimble R-8, Model 3
Receiver S/N	5046455718
Antenna Height	2.000 Meters

Date (MM-DD-YYYY)	10-31-2016
RMSE Hz	0.006
RMSE Z	0.008
GPS Method	Static

PHOTOS:





Point ID	TW03
Project No.	29178
Project Name	VT CT River Basin
State	Vermont
County	Windham
Quad	Londonderry

	Aerial Target
	LiDAR Ground Control
X	LiDAR QC Point
	New Control
	Photo ID
	Published Control

Coordinate System
NAD83(2011)
State Plane VT
NAVD88
GEOID12B
Meters

Northing	Easting	Elevation
81321.434	475558.130	349.558

Operator	Zeke Ingram
Receiver Model	Trimble R-8, Model 3
Receiver S/N	5046455718
Antenna Height	2.000 Meters

Date (MM-DD-YYYY)	11-11-2016
RMSE Hz	0.009
RMSE Z	0.014
GPS Method	VRN

PHOTOS:





Point ID	TW04
Project No.	29178
Project Name	VT CT River Basin
State	Vermont
County	Windsor
Quad	Quechee

Aerial Target	
LiDAR Ground Control	
X LiDAR QC Point	
New Control	
Photo ID	
Published Control	

Coordinate System	NAD83(2011)
	VT SPCS
	NAVD88
	GEOID12B
	Meters

Northing	Easting	Elevation
135847.869	506063.925	122.108

Operator	Kevin Chapman
Receiver Model	Trimble R-8, Model 3
Receiver S/N	5106461067
Antenna Height	2.000 Meters

Date (MM-DD-YYYY)	11-11-2016
RMSE Hz	0.006
RMSE Z	0.008
GPS Method	VRN

PHOTOS:





Point ID	TW05
Project No.	29178
Project Name	VT CT River Basin
State	Vermont
County	Orange
Quad	Vershire

Aerial Target	
LiDAR Ground Control	
X LiDAR QC Point	
New Control	
Photo ID	
Published Control	

Coordinate System	NAD83(2011)
	VT SPCS
	NAVD88
	GEOID12B
	Meters

Northing	Easting	Elevation
162442.648	516931.441	288.195

Operator	Kevin Chapman
Receiver Model	Trimble R-8, Model 3
Receiver S/N	5106461067
Antenna Height	2.000 Meters

Date (MM-DD-YYYY)	10-31-2016
RMSE Hz	0.009
RMSE Z	0.013
GPS Method	Static

PHOTOS:





Point ID	TW06
Project No.	29178
Project Name	VT CT River Basin
State	Vermont
County	Caledonia
Quad	Burke Mountain

	Aerial Target
	LiDAR Ground Control
X	LiDAR QC Point
	New Control
	Photo ID
	Published Control

Coordinate System
NAD83(2011)
State Plane VT
NAVD88
GEOID12B
Meters

Northing	Easting	Elevation
229836.842	540596.222	236.101

Operator	Zeke Ingram
Receiver Model	Trimble R-8, Model 3
Receiver S/N	5046455718
Antenna Height	2.000 Meters

Date (MM-DD-YYYY)	10-30-2016
RMSE Hz	0.008
RMSE Z	0.010
GPS Method	Static

PHOTOS:





Point ID	TW07
Project No.	29178
Project Name	VT CT River Basin
State	Vermont
County	Orange
Quad	Randolph Center

Aerial Target	
LiDAR Ground Control	
X LiDAR QC Point	
New Control	
Photo ID	
Published Control	

Coordinate System	NAD83(2011)
	VT SPCS
	NAVD88
	GEOID12B
	Meters

Northing	Easting	Elevation
153380.692	493422.889	163.847

Operator	Kevin Chapman
Receiver Model	Trimble R-8, Model 3
Receiver S/N	5106461067
Antenna Height	2.000 Meters

Date (MM-DD-YYYY)	11-17-2016
RMSE Hz	0.008
RMSE Z	0.012
GPS Method	VRN

PHOTOS:





Forest Point Log Sheets



Point ID	FO01
Project No.	29178
Project Name	VT CT River Basin
State	Vermont
County	Windham
Quad	Londonderry

	Aerial Target
	LiDAR Ground Control
X	LiDAR QC Point
	New Control
	Photo ID
	Published Control

Coordinate System
NAD83(2011)
State Plane VT
NAVD88
GEOID12B
Meters

Northing	Easting	Elevation
71590.536	472128.931	358.549

Operator	Zeke Ingram
Instrument Model	Trimble M3 2"
Date (MM-DD-YYYY)	11/16/2016
Occupy PT	CA01
Back Sight PT	BE42
RMSE Hz	0.019
RMSE Z	0.022

PHOTOS:





Point ID	FO02
Project No.	29178
Project Name	VT CT River Basin
State	Vermont
County	Windham
Quad	Saxton's River

	Aerial Target
	LiDAR Ground Control
X	LiDAR QC Point
	New Control
	Photo ID
	Published Control

Coordinate System
NAD83(2011)
State Plane VT
NAVD88
GEOID12B
Meters

Northing	Easting	Elevation
74182.274	490829.782	257.342

Operator	Zeke Ingram
Instrument Model	Trimble M3 2"
Date (MM-DD-YYYY)	11/16/2016
Occupy PT	CA02
Back Sight PT	BE01
RMSE Hz	0.017
RMSE Z	0.020

PHOTOS:





Point ID	FO03
Project No.	29178
Project Name	VT CT River Basin
State	Vermont
County	Windham
Quad	Windham

	Aerial Target
	LiDAR Ground Control
X	LiDAR QC Point
	New Control
	Photo ID
	Published Control

Coordinate System
NAD83(2011)
State Plane VT
NAVD88
GEOID12B
Meters

Northing	Easting	Elevation
75589.378	481583.209	604.294

Operator	Zeke Ingram
Instrument Model	Trimble M3 2"
Date (MM-DD-YYYY)	11/16/2016
Occupy PT	UA01
Back Sight PT	CA03
RMSE Hz	0.020
RMSE Z	0.024

PHOTOS:





Point ID	FO04
Project No.	29178
Project Name	VT CT River Basin
State	Vermont
County	Windsor
Quad	Weston

	Aerial Target
	LiDAR Ground Control
X	LiDAR QC Point
	New Control
	Photo ID
	Published Control

Coordinate System
NAD83(2011)
State Plane VT
NAVD88
GEOID12B
Meters

Northing	Easting	Elevation
87978.710	475959.283	407.543

Operator	Zeke Ingram
Instrument Model	Trimble M3 2"
Date (MM-DD-YYYY)	11/16/2016
Occupy PT	BE02
Back Sight PT	CA04
RMSE Hz	0.016
RMSE Z	0.019

PHOTOS:





Point ID	FO05
Project No.	29178
Project Name	VT CT River Basin
State	Vermont
County	Windsor
Quad	Chester

	Aerial Target
	LiDAR Ground Control
X	LiDAR QC Point
	New Control
	Photo ID
	Published Control

Coordinate System
NAD83(2011)
State Plane VT
NAVD88
GEOID12B
Meters

Northing	Easting	Elevation
84393.696	492608.728	179.520

Operator	Zeke Ingram
Instrument Model	Trimble M3 2"
Date (MM-DD-YYYY)	11/16/2016
Occupy PT	CA05
Back Sight PT	UA02
RMSE Hz	0.016
RMSE Z	0.019

PHOTOS:





Point ID	FO07
Project No.	29178
Project Name	VT CT River Basin
State	Vermont
County	Windsor
Quad	Springfield

	Aerial Target
	LiDAR Ground Control
X	LiDAR QC Point
	New Control
	Photo ID
	Published Control

Coordinate System
NAD83(2011)
State Plane VT
NAVD88
GEOID12B
Meters

Northing	Easting	Elevation
89398.534	500094.664	160.056

Operator	Zeke Ingram
Instrument Model	Trimble M3 2"
Date (MM-DD-YYYY)	11/16/2016
Occupy PT	CA06
Back Sight PT	BE03
RMSE Hz	0.019
RMSE Z	0.025

PHOTOS:





Point ID	FO08
Project No.	29178
Project Name	VT CT River Basin
State	Vermont
County	Windsor
Quad	Andover

	Aerial Target
	LiDAR Ground Control
X	LiDAR QC Point
	New Control
	Photo ID
	Published Control

Coordinate System
NAD83(2011)
State Plane VT
NAVD88
GEOID12B
Meters

Northing	Easting	Elevation
95865.722	482087.193	497.286

Operator	Zeke Ingram
Instrument Model	Trimble M3 2"
Date (MM-DD-YYYY)	11/16/2016
Occupy PT	BE04
Back Sight PT	CA07
RMSE Hz	0.017
RMSE Z	0.019

PHOTOS:





Point ID	FO09
Project No.	29178
Project Name	VT CT River Basin
State	Vermont
County	Windsor
Quad	Cavendish

	Aerial Target
	LiDAR Ground Control
X	LiDAR QC Point
	New Control
	Photo ID
	Published Control

Coordinate System
NAD83(2011)
State Plane VT
NAVD88
GEOID12B
Meters

Northing	Easting	Elevation
99963.447	498910.612	188.963

Operator	Zeke Ingram
Instrument Model	Trimble M3 2"
Date (MM-DD-YYYY)	11/16/2016
Occupy PT	CA08
Back Sight PT	UA03
RMSE Hz	0.019
RMSE Z	0.021

PHOTOS:





Point ID	FO10
Project No.	29178
Project Name	VT CT River Basin
State	Vermont
County	Windsor
Quad	Ludlow

	Aerial Target
	LiDAR Ground Control
X	LiDAR QC Point
	New Control
	Photo ID
	Published Control

Coordinate System
NAD83(2011)
State Plane VT
NAVD88
GEOID12B
Meters

Northing	Easting	Elevation
107171.199	483503.474	325.036

Operator	Zeke Ingram
Instrument Model	Trimble M3 2"
Date (MM-DD-YYYY)	11/15/2016
Occupy PT	CA10
Back Sight PT	BE05
RMSE Hz	0.024
RMSE Z	0.031

PHOTOS:





Point ID	FO11
Project No.	29178
Project Name	VT CT River Basin
State	Vermont
County	Windsor
Quad	Cavendish

	Aerial Target
	LiDAR Ground Control
X	LiDAR QC Point
	New Control
	Photo ID
	Published Control

Coordinate System
NAD83(2011)
State Plane VT
NAVD88
GEOID12B
Meters

Northing	Easting	Elevation
108910.970	496114.399	287.964

Operator	Zeke Ingram
Instrument Model	Trimble M3 2"
Date (MM-DD-YYYY)	11/16/2016
Occupy PT	CA11
Back Sight PT	UA05
RMSE Hz	0.027
RMSE Z	0.037

PHOTOS:





Point ID	FO12
Project No.	29178
Project Name	VT CT River Basin
State	Vermont
County	Windsor
Quad	Hartland

	Aerial Target
	LiDAR Ground Control
X	LiDAR QC Point
	New Control
	Photo ID
	Published Control

Coordinate System
NAD83(2011)
State Plane VT
NAVD88
GEOID12B
Meters

Northing	Easting	Elevation
111796.502	508073.607	147.186

Operator	Zeke Ingram
Instrument Model	Trimble M3 2"
Date (MM-DD-YYYY)	11/15/2016
Occupy PT	UA30
Back Sight PT	CA12
RMSE Hz	0.016
RMSE Z	0.018

PHOTOS:





Point ID	FO13
Project No.	29178
Project Name	VT CT River Basin
State	Vermont
County	Windsor
Quad	Plymouth

	Aerial Target
	LiDAR Ground Control
X	LiDAR QC Point
	New Control
	Photo ID
	Published Control

Coordinate System
NAD83(2011)
State Plane VT
NAVD88
GEOID12B
Meters

Northing	Easting	Elevation
120804.282	488091.789	254.610

Operator	Zeke Ingram
Instrument Model	Trimble M3 2"
Date (MM-DD-YYYY)	11/15/2016
Occupy PT	FO13TP
Back Sight PT	CA13
RMSE Hz	0.021
RMSE Z	0.026

PHOTOS:





Point ID	FO14
Project No.	29178
Project Name	VT CT River Basin
State	Vermont
County	Windsor
Quad	Hanover

	Aerial Target
	LiDAR Ground Control
X	LiDAR QC Point
	New Control
	Photo ID
	Published Control

Coordinate System
NAD83(2011)
State Plane VT
NAVD88
GEOID12B
Meters

Northing	Easting	Elevation
126094.856	512457.259	174.260

Operator	Zeke Ingram
Instrument Model	Trimble M3 2"
Date (MM-DD-YYYY)	11/15/2016
Occupy PT	CA14
Back Sight PT	UA06
RMSE Hz	0.018
RMSE Z	0.022

PHOTOS:





Point ID	FO15
Project No.	29178
Project Name	VT CT River Basin
State	Vermont
County	Windsor
Quad	Woodstock North

	Aerial Target
	LiDAR Ground Control
X	LiDAR QC Point
	New Control
	Photo ID
	Published Control

Coordinate System
NAD83(2011)
State Plane VT
NAVD88
GEOID12B
Meters

Northing	Easting	Elevation
134726.064	490107.034	477.426

Operator	Zeke Ingram
Instrument Model	Trimble M3 2"
Date (MM-DD-YYYY)	11/15/2016
Occupy PT	BE07
Back Sight PT	FO15BS
RMSE Hz	0.017
RMSE Z	0.020

PHOTOS:





Point ID	FO16
Project No.	29178
Project Name	VT CT River Basin
State	Vermont
County	Windsor
Quad	Woodstock North

	Aerial Target
	LiDAR Ground Control
X	LiDAR QC Point
	New Control
	Photo ID
	Published Control

Coordinate System
NAD83(2011)
State Plane VT
NAVD88
GEOID12B
Meters

Northing	Easting	Elevation
125364.204	499402.505	204.737

Operator	Zeke Ingram
Instrument Model	Trimble M3 2"
Date (MM-DD-YYYY)	11/15/2016
Occupy PT	FO16TP
Back Sight PT	BE08
RMSE Hz	0.021
RMSE Z	0.024

PHOTOS:





Point ID	FO17
Project No.	29178
Project Name	VT CT River Basin
State	Vermont
County	Windsor
Quad	Bethel

	Aerial Target
	LiDAR Ground Control
X	LiDAR QC Point
	New Control
	Photo ID
	Published Control

Coordinate System	NAD83(2011)
	State Plane VT
	NAVD88
	GEOID12B
	Meters

Northing	Easting	Elevation
148373.672	488252.076	172.641

Operator	Zeke Ingram
Instrument Model	Trimble M3 2"
Date (MM-DD-YYYY)	11/15/2016
Occupy PT	FO17TP
Back Sight PT	FO17BS
RMSE Hz	0.021
RMSE Z	0.021

PHOTOS:





Point ID	FO18
Project No.	29178
Project Name	VT CT River Basin
State	Vermont
County	Windsor
Quad	Sharon

	Aerial Target
	LiDAR Ground Control
X	LiDAR QC Point
	New Control
	Photo ID
	Published Control

Coordinate System
NAD83(2011)
State Plane VT
NAVD88
GEOID12B
Meters

Northing	Easting	Elevation
142550.915	502782.433	176.046

Operator	Zeke Ingram
Instrument Model	Trimble M3 2"
Date (MM-DD-YYYY)	11/15/2016
Occupy PT	FO18TP
Back Sight PT	CA18
RMSE Hz	0.018
RMSE Z	0.024

PHOTOS:





Point ID	FO19
Project No.	29178
Project Name	VT CT River Basin
State	Vermont
County	Orange
Quad	Lyme

	Aerial Target
	LiDAR Ground Control
X	LiDAR QC Point
	New Control
	Photo ID
	Published Control

Coordinate System	NAD83(2011)
	State Plane VT
	NAVD88
	GEOID12B
	Meters

Northing	Easting	Elevation
145717.124	523044.748	206.601

Operator	Zeke Ingram
Instrument Model	Trimble M3 2"
Date (MM-DD-YYYY)	11/10/2016
Occupy PT	CA19
Back Sight PT	BE10
RMSE Hz	0.017
RMSE Z	0.020

PHOTOS:





Point ID	FO20
Project No.	29178
Project Name	VT CT River Basin
State	Vermont
County	Orange
Quad	Sharon

	Aerial Target
	LiDAR Ground Control
X	LiDAR QC Point
	New Control
	Photo ID
	Published Control

Coordinate System
NAD83(2011)
State Plane VT
NAVD88
GEOID12B
Meters

Northing	Easting	Elevation
148354.358	511296.087	269.935

Operator	Zeke Ingram
Instrument Model	Trimble M3 2"
Date (MM-DD-YYYY)	11/14/2016
Occupy PT	CA20
Back Sight PT	UA08
RMSE Hz	0.017
RMSE Z	0.017

PHOTOS:





Point ID	FO21
Project No.	29178
Project Name	VT CT River Basin
State	Vermont
County	Orange
Quad	Randolph

	Aerial Target
	LiDAR Ground Control
X	LiDAR QC Point
	New Control
	Photo ID
	Published Control

Coordinate System
NAD83(2011)
State Plane VT
NAVD88
GEOID12B
Meters

Northing	Easting	Elevation
155795.675	487651.183	214.260

Operator	Zeke Ingram
Instrument Model	Trimble M3 2"
Date (MM-DD-YYYY)	11/15/2016
Occupy PT	CA21
Back Sight PT	BE11
RMSE Hz	0.018
RMSE Z	0.020

PHOTOS:





Point ID	FO22
Project No.	29178
Project Name	VT CT River Basin
State	Vermont
County	Orange
Quad	Chelsea

	Aerial Target
	LiDAR Ground Control
X	LiDAR QC Point
	New Control
	Photo ID
	Published Control

Coordinate System
NAD83(2011)
State Plane VT
NAVD88
GEOID12B
Meters

Northing	Easting	Elevation
164647.041	504027.000	248.158

Operator	Zeke Ingram
Instrument Model	Trimble M3 2"
Date (MM-DD-YYYY)	11/14/2016
Occupy PT	BE12
Back Sight PT	CA22
RMSE Hz	0.017
RMSE Z	0.018

PHOTOS:





Point ID	FO23
Project No.	29178
Project Name	VT CT River Basin
State	Vermont
County	Orange
Quad	Randolph

	Aerial Target
	LiDAR Ground Control
X	LiDAR QC Point
	New Control
	Photo ID
	Published Control

Coordinate System
NAD83(2011)
State Plane VT
NAVD88
GEOID12B
Meters

Northing	Easting	Elevation
166274.923	487749.195	227.142

Operator	Zeke Ingram
Instrument Model	Trimble M3 2"
Date (MM-DD-YYYY)	11/15/2016
Occupy PT	BE13
Back Sight PT	CA23
RMSE Hz	0.018
RMSE Z	0.021

PHOTOS:





Point ID	FO24
Project No.	29178
Project Name	VT CT River Basin
State	Vermont
County	Orange
Quad	Chelsea

	Aerial Target
	LiDAR Ground Control
X	LiDAR QC Point
	New Control
	Photo ID
	Published Control

Coordinate System
NAD83(2011)
State Plane VT
NAVD88
GEOID12B
Meters

Northing	Easting	Elevation
158138.208	502567.752	194.028

Operator	Zeke Ingram
Instrument Model	Trimble M3 2"
Date (MM-DD-YYYY)	11/14/2016
Occupy PT	BE15
Back Sight PT	CA24
RMSE Hz	0.017
RMSE Z	0.023

PHOTOS:





Point ID	FO25
Project No.	29178
Project Name	VT CT River Basin
State	Vermont
County	Orange
Quad	West Topsham

	Aerial Target
	LiDAR Ground Control
X	LiDAR QC Point
	New Control
	Photo ID
	Published Control

Coordinate System
NAD83(2011)
State Plane VT
NAVD88
GEOID12B
Meters

Northing	Easting	Elevation
156700.854	518981.123	234.007

Operator	Zeke Ingram
Instrument Model	Trimble M3 2"
Date (MM-DD-YYYY)	11/10/2016
Occupy PT	BE16
Back Sight PT	CA25
RMSE Hz	0.020
RMSE Z	0.022

PHOTOS:





Point ID	FO26
Project No.	29178
Project Name	VT CT River Basin
State	Vermont
County	Orange
Quad	Fairlee

	Aerial Target
	LiDAR Ground Control
X	LiDAR QC Point
	New Control
	Photo ID
	Published Control

Coordinate System
NAD83(2011)
State Plane VT
NAVD88
GEOID12B
Meters

Northing	Easting	Elevation
157339.419	529609.075	130.690

Operator	Zeke Ingram
Instrument Model	Trimble M3 2"
Date (MM-DD-YYYY)	11/10/2016
Occupy PT	CA26
Back Sight PT	BE17
RMSE Hz	0.018
RMSE Z	0.019

PHOTOS:





Point ID	FO27
Project No.	29178
Project Name	VT CT River Basin
State	Vermont
County	Orange
Quad	West Topsham

	Aerial Target
	LiDAR Ground Control
X	LiDAR QC Point
	New Control
	Photo ID
	Published Control

Coordinate System
NAD83(2011)
State Plane VT
NAVD88
GEOID12B
Meters

Northing	Easting	Elevation
168224.457	519242.400	254.686

Operator	Zeke Ingram
Instrument Model	Trimble M3 2"
Date (MM-DD-YYYY)	11/10/2016
Occupy PT	CA27
Back Sight PT	FO27BS
RMSE Hz	0.017
RMSE Z	0.019

PHOTOS:





Point ID	FO28
Project No.	29178
Project Name	VT CT River Basin
State	Vermont
County	Orange
Quad	West Topsham

	Aerial Target
	LiDAR Ground Control
X	LiDAR QC Point
	New Control
	Photo ID
	Published Control

Coordinate System
NAD83(2011)
State Plane VT
NAVD88
GEOID12B
Meters

Northing	Easting	Elevation
177838.189	515687.800	309.149

Operator	Zeke Ingram
Instrument Model	Trimble M3 2"
Date (MM-DD-YYYY)	11/10/2016
Occupy PT	CA28
Back Sight PT	FO28BS
RMSE Hz	0.018
RMSE Z	0.021

PHOTOS:





Point ID	FO29
Project No.	29178
Project Name	VT CT River Basin
State	Vermont
County	Orange
Quad	East Corinth

	Aerial Target
	LiDAR Ground Control
X	LiDAR QC Point
	New Control
	Photo ID
	Published Control

Coordinate System
NAD83(2011)
State Plane VT
NAVD88
GEOID12B
Meters

Northing	Easting	Elevation
174170.564	529911.087	294.922

Operator	Zeke Ingram
Instrument Model	Trimble M3 2"
Date (MM-DD-YYYY)	11/10/2016
Occupy PT	BE20
Back Sight PT	CA29
RMSE Hz	0.018
RMSE Z	0.021

PHOTOS:





Point ID	FO30
Project No.	29178
Project Name	VT CT River Basin
State	Vermont
County	Orange
Quad	Woodsville

	Aerial Target
	LiDAR Ground Control
X	LiDAR QC Point
	New Control
	Photo ID
	Published Control

Coordinate System
NAD83(2011)
State Plane VT
NAVD88
GEOID12B
Meters

Northing	Easting	Elevation
183752.610	533019.100	194.960

Operator	Zeke Ingram
Instrument Model	Trimble M3 2"
Date (MM-DD-YYYY)	11/6/2016
Occupy PT	CA30
Back Sight PT	FO30BS
RMSE Hz	0.016
RMSE Z	0.016

PHOTOS:





Point ID	FO31
Project No.	29178
Project Name	VT CT River Basin
State	Vermont
County	Caledonia
Quad	Woodsville

	Aerial Target
	LiDAR Ground Control
X	LiDAR QC Point
	New Control
	Photo ID
	Published Control

Coordinate System
NAD83(2011)
State Plane VT
NAVD88
GEOID12B
Meters

Northing	Easting	Elevation
193097.704	535517.303	157.804

Operator	Zeke Ingram
Instrument Model	Trimble M3 2"
Date (MM-DD-YYYY)	11/9/2016
Occupy PT	FO31TP
Back Sight PT	CA32
RMSE Hz	0.017
RMSE Z	0.019

PHOTOS:





Point ID	FO32
Project No.	29178
Project Name	VT CT River Basin
State	Vermont
County	Caledonia
Quad	Mansfield

	Aerial Target
	LiDAR Ground Control
X	LiDAR QC Point
	New Control
	Photo ID
	Published Control

Coordinate System
NAD83(2011)
State Plane VT
NAVD88
GEOID12B
Meters

Northing	Easting	Elevation
198383.477	518771.715	339.970

Operator	Zeke Ingram
Instrument Model	Trimble M3 2"
Date (MM-DD-YYYY)	11/6/2016
Occupy PT	FO32TP
Back Sight PT	BE24
RMSE Hz	0.019
RMSE Z	0.023

PHOTOS:





Point ID	FO33
Project No.	29178
Project Name	VT CT River Basin
State	Vermont
County	Caledonia
Quad	Pecham

	Aerial Target
	LiDAR Ground Control
X	LiDAR QC Point
	New Control
	Photo ID
	Published Control

Coordinate System
NAD83(2011)
State Plane VT
NAVD88
GEOID12B
Meters

Northing	Easting	Elevation
202853.233	525962.498	423.508

Operator	Zeke Ingram
Instrument Model	Trimble M3 2"
Date (MM-DD-YYYY)	11/6/2016
Occupy PT	FO33TP
Back Sight PT	FO33BS
RMSE Hz	0.017
RMSE Z	0.022

PHOTOS:





Point ID	FO34
Project No.	29178
Project Name	VT CT River Basin
State	Vermont
County	Caledonia
Quad	Barnet

	Aerial Target
	LiDAR Ground Control
X	LiDAR QC Point
	New Control
	Photo ID
	Published Control

Coordinate System
NAD83(2011)
State Plane VT
NAVD88
GEOID12B
Meters

Northing	Easting	Elevation
200681.660	533563.383	205.109

Operator	Zeke Ingram
Instrument Model	Trimble M3 2"
Date (MM-DD-YYYY)	11/6/2016
Occupy PT	FO34BS
Back Sight PT	CA35
RMSE Hz	0.017
RMSE Z	0.021

PHOTOS:





Point ID	FO35
Project No.	29178
Project Name	VT CT River Basin
State	Vermont
County	Caledonia
Quad	Lower Waterford

	Aerial Target
	LiDAR Ground Control
X	LiDAR QC Point
	New Control
	Photo ID
	Published Control

Coordinate System
NAD83(2011)
State Plane VT
NAVD88
GEOID12B
Meters

Northing	Easting	Elevation
207050.818	547951.199	289.131

Operator	Zeke Ingram
Instrument Model	Trimble M3 2"
Date (MM-DD-YYYY)	11/8/2016
Occupy PT	CA36
Back Sight PT	FO35BS
RMSE Hz	0.017
RMSE Z	0.019

PHOTOS:





Point ID	FO36
Project No.	29178
Project Name	VT CT River Basin
State	Vermont
County	Caledonia
Quad	St. Johnsbury

	Aerial Target
	LiDAR Ground Control
X	LiDAR QC Point
	New Control
	Photo ID
	Published Control

Coordinate System
NAD83(2011)
State Plane VT
NAVD88
GEOID12B
Meters

Northing	Easting	Elevation
212741.258	539011.565	194.278

Operator	Zeke Ingram
Instrument Model	Trimble M3 2"
Date (MM-DD-YYYY)	11/8/2016
Occupy PT	FO36TP
Back Sight PT	CA37
RMSE Hz	0.024
RMSE Z	0.031

PHOTOS:





Point ID	FO37
Project No.	29178
Project Name	VT CT River Basin
State	Vermont
County	Caledonia
Quad	Joes Pond

	Aerial Target
	LiDAR Ground Control
X	LiDAR QC Point
	New Control
	Photo ID
	Published Control

Coordinate System
NAD83(2011)
State Plane VT
NAVD88
GEOID12B
Meters

Northing	Easting	Elevation
217008.025	522237.069	501.707

Operator	Zeke Ingram
Instrument Model	Trimble M3 2"
Date (MM-DD-YYYY)	11/8/2016
Occupy PT	CA38
Back Sight PT	FO37BS
RMSE Hz	0.016
RMSE Z	0.017

PHOTOS:





Point ID	FO38
Project No.	29178
Project Name	VT CT River Basin
State	Vermont
County	Caledonia
Quad	Lyndonville

	Aerial Target
	LiDAR Ground Control
X	LiDAR QC Point
	New Control
	Photo ID
	Published Control

Coordinate System
NAD83(2011)
State Plane VT
NAVD88
GEOID12B
Meters

Northing	Easting	Elevation
224164.598	538857.848	216.077

Operator	Zeke Ingram
Instrument Model	Trimble M3 2"
Date (MM-DD-YYYY)	11/5/2016
Occupy PT	CA39
Back Sight PT	FO38BS
RMSE Hz	0.016
RMSE Z	0.021

PHOTOS:





Point ID	FO39
Project No.	29178
Project Name	VT CT River Basin
State	Vermont
County	Essex
Quad	Miles Pond

	Aerial Target
	LiDAR Ground Control
X	LiDAR QC Point
	New Control
	Photo ID
	Published Control

Coordinate System
NAD83(2011)
State Plane VT
NAVD88
GEOID12B
Meters

Northing	Easting	Elevation
218839.858	551230.333	328.329

Operator	Zeke Ingram
Instrument Model	Trimble M3 2"
Date (MM-DD-YYYY)	11/8/2016
Occupy PT	CA40
Back Sight PT	FO39BS
RMSE Hz	0.015
RMSE Z	0.017

PHOTOS:





Point ID	FO40
Project No.	29178
Project Name	VT CT River Basin
State	Vermont
County	Essex
Quad	Gilman

	Aerial Target
	LiDAR Ground Control
X	LiDAR QC Point
	New Control
	Photo ID
	Published Control

Coordinate System
NAD83(2011)
State Plane VT
NAVD88
GEOID12B
Meters

Northing	Easting	Elevation
213041.379	562447.645	268.262

Operator	Zeke Ingram
Instrument Model	Trimble M3 2"
Date (MM-DD-YYYY)	11/8/2016
Occupy PT	FO40TP
Back Sight PT	CA41
RMSE Hz	0.016
RMSE Z	0.019

PHOTOS:





Point ID	FO41
Project No.	29178
Project Name	VT CT River Basin
State	Vermont
County	Caledonia
Quad	Stannard

	Aerial Target
	LiDAR Ground Control
X	LiDAR QC Point
	New Control
	Photo ID
	Published Control

Coordinate System
NAD83(2011)
State Plane VT
NAVD88
GEOID12B
Meters

Northing	Easting	Elevation
227326.347	529041.779	445.222

Operator	Zeke Ingram
Instrument Model	Trimble M3 2"
Date (MM-DD-YYYY)	11/8/2016
Occupy PT	CA42
Back Sight PT	FO41BS
RMSE Hz	0.017
RMSE Z	0.018

PHOTOS:





Point ID	FO42
Project No.	29178
Project Name	VT CT River Basin
State	Vermont
County	Caledonia
Quad	Sutton

	Aerial Target
	LiDAR Ground Control
X	LiDAR QC Point
	New Control
	Photo ID
	Published Control

Coordinate System
NAD83(2011)
State Plane VT
NAVD88
GEOID12B
Meters

Northing	Easting	Elevation
236969.540	538668.151	397.307

Operator	Zeke Ingram
Instrument Model	Trimble M3 2"
Date (MM-DD-YYYY)	11/8/2016
Occupy PT	CA44
Back Sight PT	FO42BS
RMSE Hz	0.015
RMSE Z	0.016

PHOTOS:





Point ID	FO43
Project No.	29178
Project Name	VT CT River Basin
State	Vermont
County	Essex
Quad	Gallup Mills

	Aerial Target
	LiDAR Ground Control
X	LiDAR QC Point
	New Control
	Photo ID
	Published Control

Coordinate System
NAD83(2011)
State Plane VT
NAVD88
GEOID12B
Meters

Northing	Easting	Elevation
230408.906	559039.652	418.805

Operator	Zeke Ingram
Instrument Model	Trimble M3 2"
Date (MM-DD-YYYY)	11/5/2016
Occupy PT	CA45
Back Sight PT	FO43BS
RMSE Hz	0.016
RMSE Z	0.017

PHOTOS:





Point ID	FO44
Project No.	29178
Project Name	VT CT River Basin
State	Vermont
County	Essex
Quad	Groveton

	Aerial Target
	LiDAR Ground Control
X	LiDAR QC Point
	New Control
	Photo ID
	Published Control

Coordinate System
NAD83(2011)
State Plane VT
NAVD88
GEOID12B
Meters

Northing	Easting	Elevation
229951.890	574305.591	264.439

Operator	Zeke Ingram
Instrument Model	Trimble M3 2"
Date (MM-DD-YYYY)	11/5/2016
Occupy PT	FO44TP
Back Sight PT	CA46
RMSE Hz	0.020
RMSE Z	0.023

PHOTOS:





Point ID	FO45
Project No.	29178
Project Name	VT CT River Basin
State	Vermont
County	Essex
Quad	Gilman

	Aerial Target
	LiDAR Ground Control
X	LiDAR QC Point
	New Control
	Photo ID
	Published Control

Coordinate System
NAD83(2011)
State Plane VT
NAVD88
GEOID12B
Meters

Northing	Easting	Elevation
220595.192	568608.677	262.503

Operator	Zeke Ingram
Instrument Model	Trimble M3 2"
Date (MM-DD-YYYY)	11/8/2016
Occupy PT	FO45TP
Back Sight PT	CA47
RMSE Hz	0.016
RMSE Z	0.021

PHOTOS:





Point ID	FO46
Project No.	29178
Project Name	VT CT River Basin
State	Vermont
County	Essex
Quad	Groveton

	Aerial Target
	LiDAR Ground Control
X	LiDAR QC Point
	New Control
	Photo ID
	Published Control

Coordinate System
NAD83(2011)
State Plane VT
NAVD88
GEOID12B
Meters

Northing	Easting	Elevation
236122.203	574783.142	273.346

Operator	Zeke Ingram
Instrument Model	Trimble M3 2"
Date (MM-DD-YYYY)	11/5/2016
Occupy PT	CA48
Back Sight PT	FO46BS
RMSE Hz	0.021
RMSE Z	0.023

PHOTOS:





Point ID	FO47
Project No.	29178
Project Name	VT CT River Basin
State	Vermont
County	Essex
Quad	Seneca Mountain

	Aerial Target
	LiDAR Ground Control
X	LiDAR QC Point
	New Control
	Photo ID
	Published Control

Coordinate System
NAD83(2011)
State Plane VT
NAVD88
GEOID12B
Meters

Northing	Easting	Elevation
239871.648	556633.214	739.340

Operator	Zeke Ingram
Instrument Model	Trimble M3 2"
Date (MM-DD-YYYY)	11/5/2016
Occupy PT	FO47TP
Back Sight PT	CA49
RMSE Hz	0.019
RMSE Z	0.020

PHOTOS:





Point ID	FO48
Project No.	29178
Project Name	VT CT River Basin
State	Vermont
County	Caledonia
Quad	West Burke

	Aerial Target
	LiDAR Ground Control
X	LiDAR QC Point
	New Control
	Photo ID
	Published Control

Coordinate System
NAD83(2011)
State Plane VT
NAVD88
GEOID12B
Meters

Northing	Easting	Elevation
246681.663	543286.757	499.553

Operator	Zeke Ingram
Instrument Model	Trimble M3 2"
Date (MM-DD-YYYY)	11/5/2016
Occupy PT	FO48TP
Back Sight PT	CA50
RMSE Hz	0.019
RMSE Z	0.024

PHOTOS:





Point ID	FO49
Project No.	29178
Project Name	VT CT River Basin
State	Vermont
County	Essex
Quad	Island Pond

	Aerial Target
	LiDAR Ground Control
X	LiDAR QC Point
	New Control
	Photo ID
	Published Control

Coordinate System
NAD83(2011)
State Plane VT
NAVD88
GEOID12B
Meters

Northing	Easting	Elevation
257617.541	549378.744	360.154

Operator	Zeke Ingram
Instrument Model	Trimble M3 2"
Date (MM-DD-YYYY)	11/5/2016
Occupy PT	UA09
Back Sight PT	CA51
RMSE Hz	0.024
RMSE Z	0.031

PHOTOS:





Point ID	FO50
Project No.	29178
Project Name	VT CT River Basin
State	Vermont
County	Essex
Quad	Tinkerville

	Aerial Target
	LiDAR Ground Control
X	LiDAR QC Point
	New Control
	Photo ID
	Published Control

Coordinate System
NAD83(2011)
State Plane VT
NAVD88
GEOID12B
Meters

Northing	Easting	Elevation
262599.569	574435.771	321.742

Operator	Zeke Ingram
Instrument Model	Trimble M3 2"
Date (MM-DD-YYYY)	11/5/2016
Occupy PT	BE38
Back Sight PT	CA53
RMSE Hz	0.019
RMSE Z	0.021

PHOTOS:





Point ID	FO51
Project No.	29178
Project Name	VT CT River Basin
State	Vermont
County	Essex
Quad	Averill

	Aerial Target
	LiDAR Ground Control
X	LiDAR QC Point
	New Control
	Photo ID
	Published Control

Coordinate System
NAD83(2011)
State Plane VT
NAVD88
GEOID12B
Meters

Northing	Easting	Elevation
267670.951	563124.340	531.536

Operator	Zeke Ingram
Instrument Model	Trimble M3 2"
Date (MM-DD-YYYY)	11/5/2016
Occupy PT	BE39
Back Sight PT	CA54
RMSE Hz	0.019
RMSE Z	0.022

PHOTOS:





Point ID	FO52
Project No.	29178
Project Name	VT CT River Basin
State	Vermont
County	Essex
Quad	Norton Pond

	Aerial Target
	LiDAR Ground Control
X	LiDAR QC Point
	New Control
	Photo ID
	Published Control

Coordinate System	NAD83(2011)
	State Plane VT
	NAVD88
	GEOID12B
	Meters

Northing	Easting	Elevation
267922.905	549322.125	421.934

Operator	Zeke Ingram
Instrument Model	Trimble M3 2"
Date (MM-DD-YYYY)	11/5/2016
Occupy PT	CA55
Back Sight PT	FO52BS
RMSE Hz	0.018
RMSE Z	0.020

PHOTOS:





Point ID	FO53
Project No.	29178
Project Name	VT CT River Basin
State	Vermont
County	Essex
Quad	Norton Port of Entry

	Aerial Target
	LiDAR Ground Control
X	LiDAR QC Point
	New Control
	Photo ID
	Published Control

Coordinate System
NAD83(2011)
State Plane VT
NAVD88
GEOID12B
Meters

Northing	Easting	Elevation
279091.262	555834.099	390.012

Operator	Zeke Ingram
Instrument Model	Trimble M3 2"
Date (MM-DD-YYYY)	11/5/2016
Occupy PT	CA56
Back Sight PT	BE40
RMSE Hz	0.016
RMSE Z	0.018

PHOTOS:





Point ID	FO54
Project No.	29178
Project Name	VT CT River Basin
State	Vermont
County	Essex
Quad	Monadnock Mountain

	Aerial Target
	LiDAR Ground Control
X	LiDAR QC Point
	New Control
	Photo ID
	Published Control

Coordinate System
NAD83(2011)
State Plane VT
NAVD88
GEOID12B
Meters

Northing	Easting	Elevation
275769.978	573472.417	380.101

Operator	Zeke Ingram
Instrument Model	Trimble M3 2"
Date (MM-DD-YYYY)	11/5/2016
Occupy PT	CA57
Back Sight PT	BE49
RMSE Hz	0.016
RMSE Z	0.021

PHOTOS:





Point ID	FO55
Project No.	29178
Project Name	VT CT River Basin
State	Vermont
County	Orange
Quad	Washington

	Aerial Target
	LiDAR Ground Control
X	LiDAR QC Point
	New Control
	Photo ID
	Published Control

Coordinate System
NAD83(2011)
State Plane VT
NAVD88
GEOID12B
Meters

Northing	Easting	Elevation
173260.257	503484.235	511.418

Operator	Zeke Ingram
Instrument Model	Trimble M3 2"
Date (MM-DD-YYYY)	11/10/2016
Occupy PT	FO55TP
Back Sight PT	FO55BS
RMSE Hz	0.022
RMSE Z	0.025

PHOTOS:





Point ID	FO56
Project No.	29178
Project Name	VT CT River Basin
State	Vermont
County	Essex
Quad	Stratford

	Aerial Target
	LiDAR Ground Control
X	LiDAR QC Point
	New Control
	Photo ID
	Published Control

Coordinate System
NAD83(2011)
State Plane VT
NAVD88
GEOID12B
Meters

Northing	Easting	Elevation
246008.100	570598.029	286.828

Operator	Zeke Ingram
Instrument Model	Trimble M3 2"
Date (MM-DD-YYYY)	11/5/2016
Occupy PT	FO56TP
Back Sight PT	FO56BS
RMSE Hz	0.020
RMSE Z	0.022

PHOTOS:





Brushland Point Log Sheets



Point ID	SH01
Project No.	29178
Project Name	VT CT River Basin
State	Vermont
County	Windsor
Quad	Chester

Aerial Target	
LiDAR Ground Control	
X LiDAR QC Point	
New Control	
Photo ID	
Published Control	

Coordinate System	NAD83(2011)
State Plane VT	NAVD88
GEOID12B	
Meters	

Northing	Easting	Elevation
91549.862	491325.881	217.389

Operator	Zeke Ingram
Receiver Model	Trimble R-8, Model 3
Receiver S/N	5046455718
Antenna Height	2.000 Meters

Date (MM-DD-YYYY)	11-12-2016
RMSE Hz	0.010
RMSE Z	0.014
GPS Method	STATIC

PHOTOS:





Point ID	SH02
Project No.	29178
Project Name	VT CT River Basin
State	Vermont
County	Orange
Quad	Groton

Aerial Target	
LiDAR Ground Control	
X LiDAR QC Point	
New Control	
Photo ID	
Published Control	

Coordinate System	NAD83(2011)
	VT SPCS
	NAVD88
	GEOID12B
	Meters

Northing	Easting	Elevation
190028.895	524150.670	241.562

Operator	Kevin Chapman
Receiver Model	Trimble R-8, Model 3
Receiver S/N	5106461067
Antenna Height	2.000 Meters

Date (MM-DD-YYYY)	10-30-2016
RMSE Hz	0.007
RMSE Z	0.009
GPS Method	Static

PHOTOS:





Point ID	SH03
Project No.	29178
Project Name	VT CT River Basin
State	Vermont
County	Essex
Quad	Bloomfield

Aerial Target	
LiDAR Ground Control	
X LiDAR QC Point	
New Control	
Photo ID	
Published Control	

Coordinate System	NAD83(2011)
State Plane VT	NAVD88
	GEOID12B
	Meters

Northing	Easting	Elevation
253214.161	559463.935	350.880

Operator	Zeke Ingram
Receiver Model	Trimble R-8, Model 3
Receiver S/N	5046455718
Antenna Height	2.000 Meters

Date (MM-DD-YYYY)	11-1-2016
RMSE Hz	0.009
RMSE Z	0.014
GPS Method	VRN

PHOTOS:

