

GROUND CONTROL SURVEY REPORT

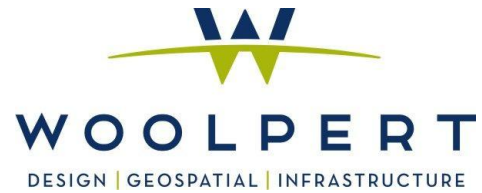

UNITED STATES GEOLOGICAL SURVEY ELWHA RIVER LIDAR 2014 W/MODIFICATION

1/7/2015

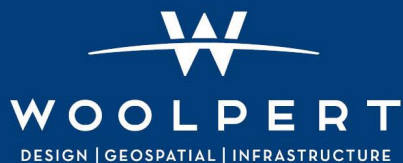

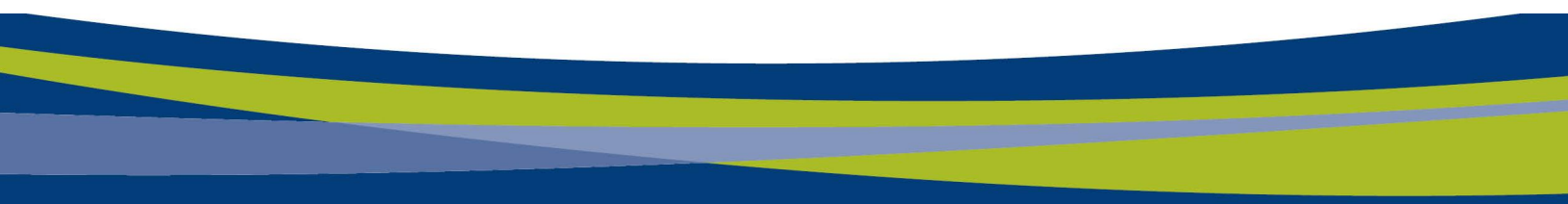

WOOLPERT

DESIGN | GEOSPATIAL | INFRASTRUCTURE



QUALITY

At Woolpert, quality is the cornerstone of our business. We invite your comments and suggestions for improving this document.

TRADEMARKS

All brand names and product names are trademarks or registered trademarks of their respective companies.

NOTICE OF PROPRIETARY INFORMATION

©2015 Woolpert, Inc., Englewood, CO.

All rights reserved to Woolpert. This document was designed, prepared, and submitted by Woolpert to be used only by the recipient.

None of this material is permitted to be reproduced in any way or distributed to anyone other than the authorized representatives of the recipient.

Table of Contents

Section 1: Survey Report	
Introduction	1-1
Project Area	1-1
Purpose.....	1-1
Date of Survey	1-1
Monumentation	1-1
Accuracy	1-1
GPS Equipment.....	1-1
Methodology.....	1-1
GPS Data Analysis and Processing	1-1
Datum Reference and Final Coordinates	1-1
Quality Assurance.....	1-1
Section 2: Ground/Geodetic Control Coordinates Listings	2-1
Section 3: Ground/Geodetic Control Logs and Photos	3-1
Section 4: Existing NGS Datasheets	4-1
Section 5: GPS Control Diagram	5-1

SECTION 1: SURVEY REPORT

INTRODUCTION

Report Date: 1/7/2015

Project Name: Elwah River LiDAR 2014 with Modification
Client Information: USGS
Contract Number: G10PC00057
Requisition/Reference Number: G14PD00287
Date of Contract: 9/23/2014
Delivery Date: 9/23/2015

Prepared By: David Kuxhausen, PLS
Woolpert Project Number: 74275

This report contains a comprehensive outline of the LiDAR Ground Control Survey that supported the Elwah River LiDAR 2014 with Modification. All surveys were performed in such a way as to achieve ground control accuracies that meet or exceed the National Mapping Accuracy Standards.

PROJECT AREA

The project area consists of approximately 100 square miles encompassing the Elwah River and surrounding areas.

PURPOSE

The purpose of this survey was to establish three-dimensional coordinates for 25 ground control points (GCPs) and a minimum of 141 quality control (QC) points in each of the land cover classifications in Bare Earth and Weeds and Crops.

The GCPs were located on open, bare earth surfaces with a level slope to enable effective assessment of swath-to-swath reproducibility and absolute accuracy. The QC points were collected uniformly dispersed over the project area in the appropriate land cover categories to verify fundamental, supplemental, and consolidated vertical accuracies throughout the task order AOI.

DATE OF SURVEY

Ground control field operations took place on November 19th 2014 thru November 21st 2014.

MONUMENTATION

Prior to aerial imagery acquisition, Woolpert field crews performed a field reconnaissance to verify the existence and suitability of pre-selected existing National Geodetic Survey (NGS) control stations. These existing bench marks were utilized as checks to ensure that quality x , y , and z coordinate values were computed for each of the newly established photogrammetric control stations. Recovery information sheets for the existing NGS control stations can be found in Section 5 of this report. A control diagram showing the ground control stations used to support this LiDAR mapping project can be found in Section 6 of this report.

ACCURACY STANDARDS

The data collected under this task order shall meet the National Standard for spatial Database Accuracy (NSSDA) standards. The NSSDA standards specify that vertical accuracy be reported at the 95 percent confidence level for data tested by an independent source of higher accuracy.

The Fundamental Vertical Accuracy (FVA): 18.13 cm at a 95% confidence level, derived according to NSSDA, i.e., based on $RMSE_z$ of 9.25 cm in the "open terrain" land cover category.

The Supplemental Vertical Accuracy (SVA): The SVA will be reported for each of the land cover classes within the task order AOI. The target SVA is 26.9 cm at a 95th percentile level, derived according to ASPRS Guidelines, Vertical Accuracy Reporting for Lidar Data, i.e., based on the 95th percentile error for each required land cover class.

The Consolidated Vertical Accuracy (CVA): 26.9 cm at a 95th percentile level, derived according to ASPRS Guidelines, Vertical Accuracy Reporting for Lidar Data, i.e., based on the 95th percentile error in all land cover categories combined.

Automated and manual filtering for lidar products shall use the following minimum performance for artifact/feature removal from the bare earth model: The bare earth surface model shall have a minimum of 95% of surface canopy artifacts, including buildings, vegetation, bridges or overpass structures removed.

GPS EQUIPMENT

Woolpert utilized 2 Trimble Navigation R8 Model 4 GNSS dual-frequency GPS receivers with a Trimble TDL-450 radio as dual base stations. Additionally, Woolpert utilized a Trimble Navigation R8 Model 3 GNSS dual-frequency GPS receiver and a TSC3 data collector as a rover for this project.

METHODOLOGY

REAL-TIME KINEMATIC (RTK) GPS

The field crew utilized Real-Time Kinematic (RTK) GPS surveying throughout most of the ground control data collection process. Using RTK GPS techniques, observations were performed on a total of 25 LiDAR control points and 156 ground control quality check points. The survey was conducted using a 5-second epoch rate, in a fixed solution RTK mode, with each observation lasting between 60 to 180 seconds. Each station was occupied twice to insure the necessary horizontal and vertical accuracies were being met for this photogrammetric project.

FAST-STATIC GPS

In addition to the RTK GPS techniques, the project field crew utilized Fast-static GPS surveying techniques on the three temporary survey marks that were established within the project area using a 5-second epoch collection rate.

Using Fast-Static GPS techniques, observations were performed on three (3) Temporary control points and one NGS mark named 944 4090 A TIDAL (PID# TR2551). The survey was conducted at a 5-second sync rate with each observation lasting between 4-10 hours.

GPS DATA ANALYSIS AND PROCESSING

The field crew chief processed all session baselines each day using Trimble Navigation's Trimble Business Center (TBC) Version 3.40 baseline processor with the accompanying broadcast ephemeris. Daily processing ensured the integrity of the network as it was constructed, and allowed the field crews to immediately reschedule observations of poor baselines. Once the field work was complete, the processed baselines were then run through a rigorous loop closure analysis. As a result of this analysis, unacceptable GPS vectors were removed and field blunders, if any, were detected and eliminated. Once this process was completed, both unconstrained and constrained adjustments were conducted in order to effectively incorporate the static observation data.

The GPS base stations and constrained geodetic control stations consisted of the following:

Point Designation	NGS PID	Type	Constrained
100	N/A	TSM	3d
101	N/A	TSM	3d
102	N/A	TSM	3d
944 4090 A TIDAL	TR2551	NGS	2d

Stations 100, 101 and 102 were used as temporary control base stations. These points were

established by utilizing the 5-second epoch static data that was collected over a three day period. The raw data was sent to the NGS Online Positioning User System "OPUS" to establish the final coordinates. The NGS mark 944 4090 A TIDAL and its associated horizontal datasheet coordinates were also used as one of the primary geodetic control marks on this project.

DATUM REFERENCE AND FINAL COORDINATES

New horizontal GPS control within the Elwah River LiDAR project area was based on the UTM Coordinate System Zone 10 North, referenced to North American Datum 1983, national re-adjustment of 2011 (NAD83/2011) epoch 2010.00, expressed in meters. All vertical control was based on the North American Vertical Datum of 1988 (NAVD88), also expressed in meters. These coordinates for the LiDAR control survey can be found in Section 2 of this report.

QUALITY ASSURANCE

Existing NGS published bench marks were surveyed to assure that there were no discrepancies in the field observation data. Close examinations of the residuals showed no distortions in orientation or scale.

The ground control data meets positional accuracies necessary to support 1.0 point per 0.3 meters squared (1' GSD) data at 95% confidence level as outlined in the *Geospatial Positioning Accuracy Standards, Part 3: National Standard for Spatial Data Accuracy (NSSDA)*, published by the Federal Geographic Data Committee (FGDC-STD-007.3-1998).

SECTION 2: GROUND/GEODETIC CONTROL COORDINATE LISTINGS

COORDINATE SYSTEM: GRID

HORIZONTAL DATUM: NAD83 2011 UTM Zone 10-N

VERTICAL DATUM: NAVD88

ZONE: 10-North

GEOID MODEL: GEOID 12A

UNITS: Meters

LIDAR GROUND CONTROL

Point	UTM Zone 10-North		Elevation (m)	Description
	Northing (m)	Easting (m)		
1000	5333139	452056.5	71.554	LIDAR CONTROL
1001	5331694	453204.9	73.446	LIDAR CONTROL
1002	5331178	456264.7	67.878	LIDAR CONTROL
1003	5333078	458585	4.465	LIDAR CONTROL
1004	5332144	468264.8	4.379	LIDAR CONTROL
1005	5330967	464687.4	42.847	LIDAR CONTROL
1006	5329375	460482.2	88.343	LIDAR CONTROL
1007	5323800	454607.7	123.255	LIDAR CONTROL
1008	5326170	446538.3	201.973	LIDAR CONTROL
1009	5325384	445862.9	166.335	LIDAR CONTROL
1010	5323193	463232.4	278.544	LIDAR CONTROL
1011	5320866	468103.6	546.285	LIDAR CONTROL
1012	5317636	455984.9	121.037	LIDAR CONTROL
1013	5312931	456494.4	354.467	LIDAR CONTROL
1014	5314598	454225.7	462.229	LIDAR CONTROL
1015	5321854	455099.3	182.1	LIDAR CONTROL
1016	5323416	459810	197.535	LIDAR CONTROL
1017	5330526	457499.4	73.321	LIDAR CONTROL
1018	5319535	456051.4	95.163	LIDAR CONTROL
1019	5327470	458733.1	100.362	LIDAR CONTROL
1020	5323429	455949.2	124.581	LIDAR CONTROL
1021	5325905	448931	489.494	LIDAR CONTROL
1022	5326657	445766.5	255.659	LIDAR CONTROL
1023	5324482	447747	281.281	LIDAR CONTROL
1024	5324620	447541.6	271.581	LIDAR CONTROL

QUALITY CONTROL POINTS

Point	UTM Zone 10-North		Elevation (m)	Description
	Northing (m)	Easting (m)		
2000	5331703.742	453187.63	73.169	BARE EARTH
2000A	5331681.736	453189.96	74.978	BARE EARTH
2002	5332129.183	468101.644	3.501	BARE EARTH
2002A	5332131.674	468080.389	3.736	BARE EARTH
2004	5330533.947	457587.306	73.156	BARE EARTH
2004A	5330515.389	457598.583	73.608	BARE EARTH
2005	5327444.57	458744.952	101.233	BARE EARTH
2005A	5327484.504	458745.247	100.394	BARE EARTH
2006	5323669.123	454929.657	123.492	BARE EARTH
2006A	5323682.623	454905.049	122.333	BARE EARTH
2007	5326015.873	447074.238	192.312	BARE EARTH
2007A	5326023.352	447054.136	193.288	BARE EARTH
2008	5322921.982	462661.68	311.768	BARE EARTH
2008A	5322906.028	462650.012	312.97	BARE EARTH
2009	5321782.71	455093.183	185.316	BARE EARTH
2009A	5321770.016	455093.1	185.656	BARE EARTH
2010	5332478.03	459343.332	4.656	BARE EARTH
2010A	5332479.175	459314.463	4.542	BARE EARTH
2011	5333217.996	452248.889	47.45	BARE EARTH
2011A	5333194.12	452259.315	47.692	BARE EARTH
2012	5332688.933	457739.577	3.806	BARE EARTH
2012A	5332708.282	457746.348	3.155	BARE EARTH
2013	5330860.244	462046.904	46.952	BARE EARTH
2013A	5330873.567	462054.717	46.507	BARE EARTH
2014	5323588.264	457707.051	76.042	BARE EARTH
2014A	5323583.509	457697.634	75.487	BARE EARTH
2015	5320959.379	468046.895	557.048	BARE EARTH
2015A	5320952.428	468039.405	555.615	BARE EARTH
2017	5331501.483	459321.92	9.952	BARE EARTH
2017A	5331487.153	459322.011	9.981	BARE EARTH
2018	5326071.861	446380.342	187.484	BARE EARTH
2018A	5326062.194	446366.039	187.353	BARE EARTH
2019	5328892.831	460058.537	105.951	BARE EARTH
2019A	5328876.592	460074.385	105.626	BARE EARTH
2020	5325908.52	448947.504	490.201	BARE EARTH
2020A	5325919.952	448947.122	491.46	BARE EARTH
3000	5331713.07	453094.665	75.164	URBAN

Point	UTM Zone 10-North		Elevation (m)	Description
	Northing (m)	Easting (m)		
3000A	5331716.81	453111.739	74.888	URBAN
3001A	5333135.839	452075.237	68.623	TREE
3002	5332493.482	459732.219	4.276	TREE
3002A	5332492.195	459750.432	4.247	TREE
3003	5331203.072	456269.738	67.31	URBAN
3003A	5331194.123	456287.727	68.201	URBAN
3004	5330530.048	457758.587	72.888	URBAN
3004A	5330521.297	457753.456	72.962	URBAN
3005	5327507.938	458763.116	100.46	URBAN
3005A	5327519.346	458769.867	100.236	URBAN
3006	5323567.572	457804.726	78.555	TREE
3006A	5323571.938	457795.806	78.424	TREE
3007	5323820.495	454625.562	123.957	TREE
3007A	5323834.9	454626.707	124.067	TREE
3008	5326164.38	446522.122	201.485	TREE
3008A	5326148.332	446558.257	200.451	TREE
3009	5325480.493	445926.735	156.076	TREE
3009A	5325469.583	445930.827	156.234	TREE
3010	5323345.789	460514.636	230.241	TREES
3010A	5323362.599	460519.859	233.031	TREES
3011	5320866.127	468110.642	546.448	TREES
3011A	5320848.993	468090.642	545.607	TREES
3011B	5325384.472	445862.936	166.333	LIDAR CONTROL
3012	5321183.974	467757.946	571.825	TREE
3012A	5321181.31	467771.887	571.585	TREE
3013	5321821.385	455126.277	180.322	TREE
3013A	5321822.509	455147.087	178.887	TREE
3014	5319523.4	456044.292	95.572	BARE GRND
3014A	5319549.932	456052.128	95.184	BARE GRND
3015	5317558.97	455918.02	127.929	TREE
3015A	5317552.651	455913.269	128.41	TREE
3016	5314606.253	454222.137	461.585	TREE
3016A	5314593.181	454219.745	462.591	TREE
3017	5312941.365	456475.858	353.481	TREE
3018	5316822.679	455135.564	194.793	TREE
3018A	5316821.843	455170.313	190.51	TREE
3019	5323219.559	455762.036	131.496	TREE
3019A	5323221.585	455755.212	131.463	TREE

Point	UTM Zone 10-North		Elevation (m)	Description
	Northing (m)	Easting (m)		
3020	5325933.796	448944.43	490.626	TREE
3020A	5325906.556	448922.589	489.14	TREE
3050	5324488.031	447743.521	280.418	TREE
3051	5324598.6	447515.86	270.44	TREE
3052	5324642.76	447622.009	272.409	TREE
3053	5324660.1	448120.46	166.592	BARE EARTH
3054	5324694.336	446882.807	173.638	BARE EARTH
3055	5324669.648	446895.06	173.601	BARE EARTH
4000	5331748.186	452933.803	67.903	BRUSH
4000A	5331742.767	452948.445	68.971	BRUSH
4002	5332969.893	458617.223	4.856	TREE
4002A	5332954.842	458620.901	4.893	TREE
4003A	5331872.462	459307.168	6.525	GRASS
4004	5331018.262	461806.897	41.32	TREE
4004A	5331027.91	461797.642	40.977	TREE
4006	5327449.472	458721.164	100.297	TREE
4006A	5327442.684	458699.053	100.064	TREE
4007	5323854.109	454455.541	121.985	TREE
4007A	5323858.015	454442.943	122.212	TREE
4008	5326098.667	446385.849	188.029	TREE
4008A	5326080.019	446384.935	187.765	TREE
4009	5325387.906	445848.195	167.28	TREE
4009A	5325371.406	445855.094	167.005	TREE
4010	5322051.924	454857.984	210.263	TREE
4010A	5322052.858	454868.451	209.382	TREE
4011	5323405.628	459788.12	196.812	GRASS
4011A	5323393.14	459780.183	196.601	GRASS
4012A	5322972.554	462991.774	287.742	BRUSH
4013	5321679.526	465532.312	545.668	TREE
4013A	5321703.125	465555.674	547.613	TREE
4014	5327041.022	457233.341	193.911	TREE
4014A	5327041.992	457254.027	194.5	TREE
4015	5330822.917	458012.385	58.285	TREE
4015A	5330827.25	458026.437	58.194	TREE
5000	5331663.523	453320.244	72.672	TREE
5000A	5331673.914	453318.292	72.394	TREE
5001	5331184.736	456120.079	67.087	TREE
5001A	5331194.694	456170.502	68.277	TREE

Point	UTM Zone 10-North		Elevation (m)	Description
	Northing (m)	Easting (m)		
5002	5330393.207	457490.549	75.313	TREE
5002A	5330377.292	457490.04	75.807	TREE
5003	5332969.429	458735.918	3.538	GRASS
5003A	5332973.174	458719.96	3.614	TREE
5004	5330957.21	463827.763	48.626	TREE
5004A	5330980.047	463836.653	48.204	TREE
5005	5332131.778	459336.447	6.678	GRASS
5005A	5332148.08	459336.365	6.584	GRASS
5006	5323694.732	454972.765	123.479	CROPS
5006A	5323689.564	454985.794	123.057	CROPS
5007	5324649.517	450610.821	152.456	GRASS
5007A	5324648.477	450598.831	152.836	GRASS
5008	5323257.542	455446.371	129.03	BRUSH
5008A	5323238.838	455444.264	129.765	BRUSH
5009	5321878.857	455108.176	181.076	CROPS
5009A	5321872.02	455121.434	179.937	CROPS
5010	5320677.823	455942.495	82.36	GRASS
5010A	5320662.16	456003.128	82.092	GRASS
5011	5323423.502	459858.032	198.991	TREE
5011A	5323440.229	459859.859	199.099	TREE
5012	5323022.806	462487.025	304.257	GRASS
5012A	5322998.791	462491.324	304.308	GRASS
5013	5314598.022	454235.038	462.194	TREE
5013A	5314587.308	454231.534	462.557	TREE
5014	5323349.218	457185.794	67.68	GRASS
5014A	5323333.625	457170.039	67.671	GRASS
5015	5326100.211	447157.53	206.499	GRASS
5015A	5326075.651	447153.516	201.804	GRASS

CONTROL BASE STATIONS

Point	UTM Zone 10-North		Elevation (m)	Description
	Northing (m)	Easting (m)		
100	5323736.077	456992.946	70.507	TSM
101	5328886.567	460067.030	105.806	TSM
102	5323012.130	462479.056	303.694	TSM
944 4090 A TIDAL	5330142.217	466429.312	4.113	TR2551

COORDINATE SYSTEM: GEODETIC

HORIZONTAL DATUM: NAD83 (2011) Epoch 2010.00

VERTICAL DATUM: NAVD88

UNITS: Meters

DATE: 1/7/2015

LIDAR GROUND CONTROL

Point	NAD83 (2011) Epoch 2010.00		Ellipsoid Ht. (m)	Description
	N Latitude	W Longitude		
1000	48°08'58.88877"	-123°38'40.49125"	51.49	LIDAR CONTROL
1001	48°08'12.38764"	-123°37'44.34182"	53.364	LIDAR CONTROL
1002	48°07'56.48790"	-123°35'16.09872"	47.78	LIDAR CONTROL
1003	48°08'58.55243"	-123°33'24.50465"	-15.652	LIDAR CONTROL
1004	48°08'30.33444"	-123°25'35.76199"	-15.904	LIDAR CONTROL
1005	48°07'51.53559"	-123°28'28.52952"	22.646	LIDAR CONTROL
1006	48°06'59.06527"	-123°31'51.44817"	68.231	LIDAR CONTROL
1007	48°03'57.10255"	-123°36'33.44447"	103.271	LIDAR CONTROL
1008	48°05'11.58968"	-123°43'04.40805"	181.934	LIDAR CONTROL
1009	48°04'45.95961"	-123°43'36.69673"	146.298	LIDAR CONTROL
1010	48°03'39.43293"	-123°29'36.50838"	258.621	LIDAR CONTROL
1011	48°02'25.03038"	-123°25'40.53025"	526.444	LIDAR CONTROL
1012	48°00'37.82044"	-123°35'24.61740"	101.121	LIDAR CONTROL
1013	47°58'05.53554"	-123°34'58.30666"	334.479	LIDAR CONTROL
1014	47°58'58.95218"	-123°36'48.36355"	442.249	LIDAR CONTROL
1015	48°02'54.18312"	-123°36'08.95572"	162.153	LIDAR CONTROL
1016	48°03'45.90783"	-123°32'21.94044"	177.593	LIDAR CONTROL
1017	48°07'35.65635"	-123°34'16.12745"	53.22	LIDAR CONTROL
1018	48°01'39.32974"	-123°35'22.10798"	75.239	LIDAR CONTROL
1019	48°05'56.96896"	-123°33'15.38347"	80.299	LIDAR CONTROL
1020	48°03'45.41412"	-123°35'28.48281"	104.591	LIDAR CONTROL
1021	48°05'03.73484"	-123°41'08.64065"	469.485	LIDAR CONTROL
1022	48°05'27.14185"	-123°43'41.94060"	235.619	LIDAR CONTROL
1023	48°04'17.30572"	-123°42'05.24124"	261.289	LIDAR CONTROL
1024	48°04'21.70110"	-123°42'15.22769"	251.583	LIDAR CONTROL

QUALITY CONTROL POINTS

Point	NAD83 (2011) Epoch 2010.00		Ellipsoid Ht. (m)	Description
	N Latitude	W Longitude		
2000	48°08'12.71154"	-123°37'45.18090"	53.087	BARE EARTH
2000A	48°08'11.99944"	-123°37'45.05946"	54.896	BARE EARTH
2002	48°08'29.81218"	-123°25'43.65458"	-16.779	BARE EARTH
2002A	48°08'29.88902"	-123°25'44.68381"	-16.543	BARE EARTH
2004	48°07'35.93545"	-123°34'11.87930"	53.054	BARE EARTH
2004A	48°07'35.33713"	-123°34'11.32715"	53.506	BARE EARTH
2005	48°05'56.15153"	-123°33'14.80040"	81.17	BARE EARTH
2005A	48°05'57.44498"	-123°33'14.80001"	80.331	BARE EARTH
2006	48°03'52.94325"	-123°36'17.83645"	103.504	BARE EARTH
2006A	48°03'53.37421"	-123°36'19.03060"	102.346	BARE EARTH
2007	48°05'06.77481"	-123°42'38.43528"	172.279	BARE EARTH
2007A	48°05'07.01104"	-123°42'39.41027"	173.255	BARE EARTH
2008	48°03'30.54293"	-123°30'04.00013"	291.855	BARE EARTH
2008A	48°03'30.02374"	-123°30'04.55886"	293.058	BARE EARTH
2009	48°02'51.88807"	-123°36'09.22217"	165.37	BARE EARTH
2009A	48°02'51.47693"	-123°36'09.22142"	165.71	BARE EARTH
2010	48°08'39.31230"	-123°32'47.59698"	-15.471	BARE EARTH
2010A	48°08'39.34273"	-123°32'48.99442"	-15.585	BARE EARTH
2011	48°09'01.50258"	-123°38'31.21378"	27.384	BARE EARTH
2011A	48°09'00.73209"	-123°38'30.69951"	27.625	BARE EARTH
2012	48°08'45.76657"	-123°34'05.28288"	-16.308	BARE EARTH
2012A	48°08'46.39483"	-123°34'04.96209"	-16.96	BARE EARTH
2013	48°07'47.51721"	-123°30'36.24292"	26.799	BARE EARTH
2013A	48°07'47.95038"	-123°30'35.86919"	26.355	BARE EARTH
2014	48°03'51.00920"	-123°34'03.60875"	56.063	BARE EARTH
2014A	48°03'50.85294"	-123°34'04.06204"	55.508	BARE EARTH
2015	48°02'28.02970"	-123°25'43.29412"	537.204	BARE EARTH
2015A	48°02'27.80321"	-123°25'43.65401"	535.772	BARE EARTH
2017	48°08'07.67935"	-123°32'48.29726"	-10.173	BARE EARTH
2017A	48°08'07.21526"	-123°32'48.28793"	-10.143	BARE EARTH
2018	48°05'08.37932"	-123°43'12.00087"	167.444	BARE EARTH
2018A	48°05'08.06189"	-123°43'12.68782"	167.313	BARE EARTH
2019	48°06'43.35900"	-123°32'11.77591"	85.852	BARE EARTH
2019A	48°06'42.83661"	-123°32'11.00398"	85.526	BARE EARTH
2020	48°05'03.84807"	-123°41'07.84210"	470.193	BARE EARTH
2020A	48°05'04.21821"	-123°41'07.86549"	471.451	BARE EARTH
3000	48°08'12.98900"	-123°37'49.68276"	55.083	URBAN

Point	NAD83 (2011) Epoch 2010.00		Ellipsoid Ht. (m)	Description
	N Latitude	W Longitude		
3000A	48°08'13.11465"	-123°37'48.85811"	54.807	URBAN
3001A	48°08'58.79471"	-123°38'39.58490"	48.559	TREE
3002	48°08'39.90180"	-123°32'28.78274"	-15.853	TREE
3002A	48°08'39.86428"	-123°32'27.90090"	-15.882	TREE
3003	48°07'57.28570"	-123°35'15.86564"	47.212	URBAN
3003A	48°07'57.00033"	-123°35'14.99202"	48.103	URBAN
3004	48°07'35.85019"	-123°34'03.59195"	52.784	URBAN
3004A	48°07'35.56554"	-123°34'03.83705"	52.858	URBAN
3005	48°05'58.20813"	-123°33'13.94417"	80.397	URBAN
3005A	48°05'58.57919"	-123°33'13.62176"	80.172	URBAN
3006	48°03'50.36229"	-123°33'58.88194"	58.578	TREE
3006A	48°03'50.50158"	-123°33'59.31450"	58.447	TREE
3007	48°03'57.76823"	-123°36'32.58759"	103.972	TREE
3007A	48°03'58.23504"	-123°36'32.53775"	104.082	TREE
3008	48°05'11.41857"	-123°43'05.18940"	181.447	TREE
3008A	48°05'10.90976"	-123°43'03.43550"	180.413	TREE
3009	48°04'49.08881"	-123°43'33.65707"	136.038	TREE
3009A	48°04'48.73674"	-123°43'33.45436"	136.196	TREE
3010	48°03'43.80384"	-123°31'47.87096"	210.308	TREES
3010A	48°03'44.34947"	-123°31'47.62417"	213.098	TREES
3011	48°02'25.02085"	-123°25'40.19032"	526.608	TREES
3011A	48°02'24.46231"	-123°25'41.15166"	525.768	TREES
3011B	48°04'45.95949"	-123°43'36.69677"	146.296	LIDAR CONTROL
3012	48°02'35.25172"	-123°25'57.31049"	551.983	TREE
3012A	48°02'35.16798"	-123°25'56.63645"	551.743	TREE
3013	48°02'53.14905"	-123°36'07.63829"	160.374	TREE
3013A	48°02'53.19072"	-123°36'06.63352"	158.939	TREE
3014	48°01'38.95206"	-123°35'22.44644"	75.649	BARE GRND
3014A	48°01'39.81330"	-123°35'22.07787"	75.26	BARE GRND
3015	48°00'35.29670"	-123°35'27.81590"	108.012	TREE
3015A	48°00'35.09084"	-123°35'28.04287"	108.493	TREE
3016	47°58'59.23471"	-123°36'48.53657"	441.606	TREE
3016A	47°58'58.81073"	-123°36'48.64694"	442.611	TREE
3017	47°58'05.87818"	-123°34'59.20533"	333.493	TREE
3018	48°00'11.25360"	-123°36'05.30526"	174.853	TREE
3018A	48°00'11.23533"	-123°36'03.62793"	170.57	TREE
3019	48°03'38.59268"	-123°35'37.45002"	111.51	TREE
3019A	48°03'38.65657"	-123°35'37.78049"	111.476	TREE

Point	NAD83 (2011) Epoch 2010.00		Ellipsoid Ht. (m)	Description
	N Latitude	W Longitude		
3020	48°05'04.66581"	-123°41'08.00157"	470.617	TREE
3020A	48°05'03.77729"	-123°41'09.04554"	469.132	TREE
3050	48°04'17.49143"	-123°42'05.41184"	260.426	TREE
3051	48°04'21.00511"	-123°42'16.46208"	250.443	TREE
3052	48°04'22.46676"	-123°42'11.35197"	252.411	TREE
3053	48°04'23.17505"	-123°41'47.27199"	146.599	BARE EARTH
3054	48°04'23.91699"	-123°42'47.09675"	153.63	BARE EARTH
3055	48°04'23.12109"	-123°42'46.49361"	153.594	BARE EARTH
4000	48°08'14.08354"	-123°37'57.48012"	47.823	BRUSH
4000A	48°08'13.91194"	-123°37'56.76950"	48.891	BRUSH
4002	48°08'55.07391"	-123°33'22.90778"	-15.263	TREE
4002A	48°08'54.58732"	-123°33'22.72451"	-15.226	TREE
4003A	48°08'19.69108"	-123°32'49.13869"	-13.6	GRASS
4004	48°07'52.58339"	-123°30'47.90543"	21.169	TREE
4004A	48°07'52.89386"	-123°30'48.35632"	20.827	TREE
4006	48°05'56.30478"	-123°33'15.95224"	80.234	TREE
4006A	48°05'56.07977"	-123°33'17.01895"	80.002	TREE
4007	48°03'58.81327"	-123°36'40.81574"	102.001	TREE
4007A	48°03'58.93652"	-123°36'41.42597"	102.228	TREE
4008	48°05'09.24914"	-123°43'11.74677"	167.99	TREE
4008A	48°05'08.64490"	-123°43'11.78255"	167.725	TREE
4009	48°04'46.06622"	-123°43'37.41078"	147.243	TREE
4009A	48°04'45.53393"	-123°43'37.06980"	146.968	TREE
4010	48°03'00.54757"	-123°36'20.68504"	190.319	TREE
4010A	48°03'00.58051"	-123°36'20.17980"	189.438	TREE
4011	48°03'45.57851"	-123°32'22.99370"	176.87	GRASS
4011A	48°03'45.17226"	-123°32'23.37298"	176.659	GRASS
4012A	48°03'32.25013"	-123°29'48.06806"	267.828	BRUSH
4013	48°02'50.88325"	-123°27'44.95010"	525.825	TREE
4013A	48°02'51.65212"	-123°27'43.82852"	527.769	TREE
4014	48°05'42.72268"	-123°34'27.74179"	173.865	TREE
4014A	48°05'42.75909"	-123°34'26.74206"	174.453	TREE
4015	48°07'45.39599"	-123°33'51.41806"	38.177	TREE
4015A	48°07'45.53965"	-123°33'50.73976"	38.086	TREE
5000	48°08'11.44405"	-123°37'38.74847"	52.589	TREE
5000A	48°08'11.78007"	-123°37'38.84698"	52.311	TREE
5001	48°07'56.65476"	-123°35'23.09962"	46.99	TREE
5001A	48°07'56.98977"	-123°35'20.66379"	48.179	TREE

Point	NAD83 (2011) Epoch 2010.00		Ellipsoid Ht. (m)	Description
	N Latitude	W Longitude		
5002	48°07'31.35402"	-123°34'16.50954"	55.213	TREE
5002A	48°07'30.83845"	-123°34'16.52843"	55.707	TREE
5003	48°08'55.08665"	-123°33'17.16310"	-16.582	GRASS
5003A	48°08'55.20424"	-123°33'17.93674"	-16.506	TREE
5004	48°07'51.03113"	-123°29'10.11450"	28.442	TREE
5004A	48°07'51.77259"	-123°29'09.69137"	28.021	TREE
5005	48°08'28.09644"	-123°32'47.81106"	-13.448	GRASS
5005A	48°08'28.62439"	-123°32'47.82066"	-13.542	GRASS
5006	48°03'53.78362"	-123°36'15.76326"	103.491	CROPS
5006A	48°03'53.61956"	-123°36'15.13180"	103.069	CROPS
5007	48°04'23.54423"	-123°39'46.92017"	132.473	GRASS
5007A	48°04'23.50722"	-123°39'47.49916"	132.853	GRASS
5008	48°03'39.74375"	-123°35'52.71545"	109.045	BRUSH
5008A	48°03'39.13743"	-123°35'52.81022"	109.78	BRUSH
5009	48°02'55.00586"	-123°36'08.53431"	161.128	CROPS
5009A	48°02'54.78779"	-123°36'07.89132"	159.989	CROPS
5010	48°02'16.31623"	-123°35'27.78906"	62.424	GRASS
5010A	48°02'15.82398"	-123°35'24.85514"	62.157	GRASS
5011	48°03'46.17326"	-123°32'19.62186"	179.049	TREE
5011A	48°03'46.71543"	-123°32'19.53922"	179.157	TREE
5012	48°03'33.77157"	-123°30'12.47012"	284.341	GRASS
5012A	48°03'32.99466"	-123°30'12.25484"	284.393	GRASS
5013	47°58'58.97146"	-123°36'47.91104"	442.214	TREE
5013A	47°58'58.62354"	-123°36'48.07598"	442.577	TREE
5014	48°03'43.14178"	-123°34'28.70855"	47.702	GRASS
5014A	48°03'42.63296"	-123°34'29.46414"	47.693	GRASS
5015	48°05'09.53117"	-123°42'34.44683"	186.467	GRASS
5015A	48°05'08.73452"	-123°42'34.62990"	181.772	GRASS

CONTROL BASE STATIONS

Point	NAD83 (2011) Epoch 2010.00		Ellipsoid Ht. (m)	Description
	N Latitude	W Longitude		
100	48°03'55.62462"	-123°34'38.16623"	50.516	TSM
101	48°06'43.15804"	-123°32'11.36305"	85.707	TSM
102	48°03'33.42409"	-123°30'12.85176"	283.778	TSM
944 4090 A TIAL	48°07'25.14828"	-123°27'04.01731"	-16.121	TR2551

SECTION 3: GROUND/GEODETIC CONTROL LOGS AND PHOTOS

This section contains the station recovery information sheets and photographs for the ground control, geodetic control and checkpoint stations established for the project. The stations appear as they are ordered in the final coordinate listing of Section 2.

The data is assembled on the following pages.

Elwah River LiDAR Survey - LiDAR Control



LiDAR Control point # 1000	General location Port Angeles WA	Ground Class Gravel Road
Latitude N 48° 08' 59" "	Longitude W 123° 38' 39" "	Calendar Date 11/19/14
		Observer Initials DJK

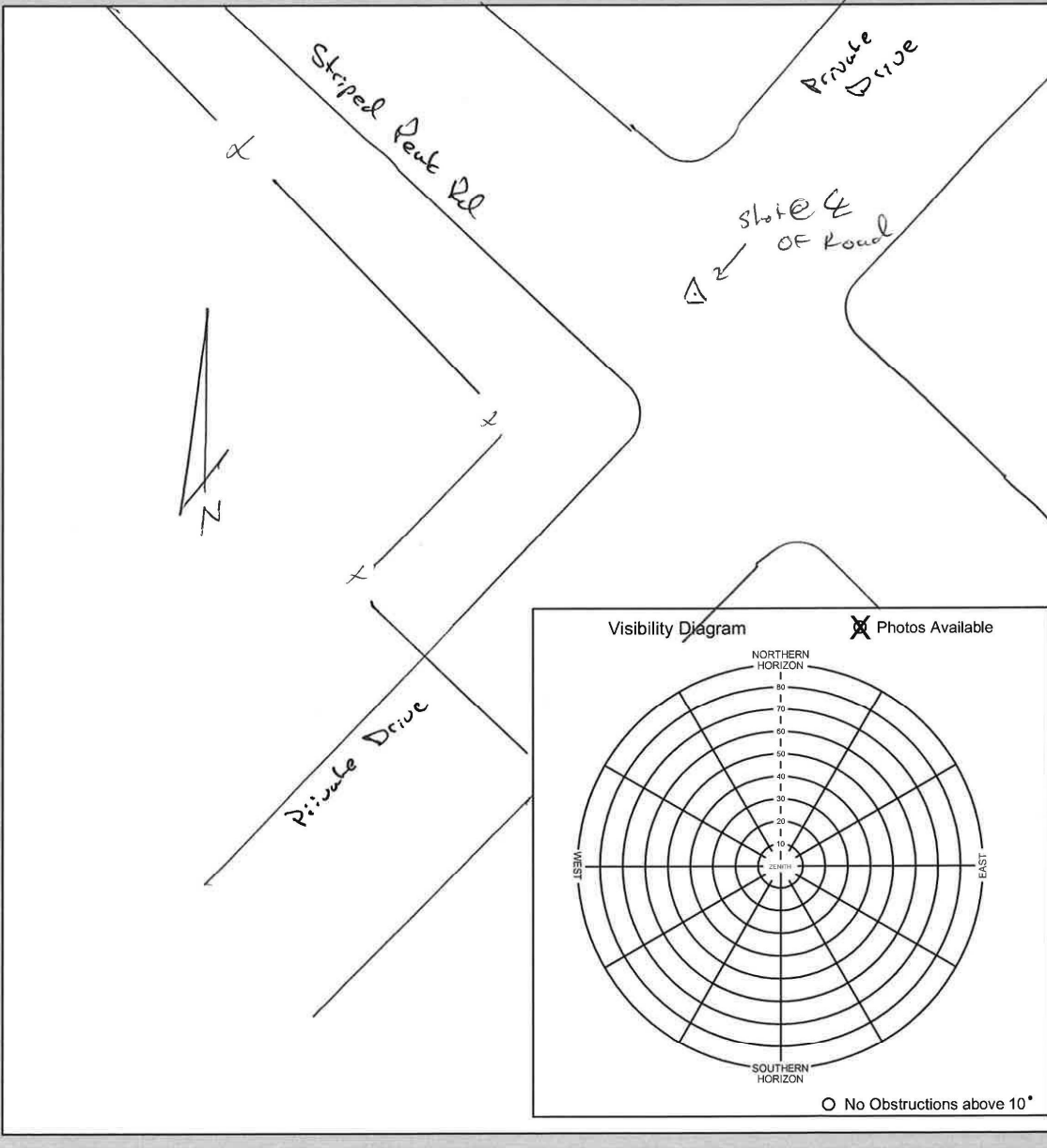



1000-W-19NOV2014

Elwah River LiDAR Survey - LiDAR Control



LiDAR Control point # 1001	General location Port Angeles, WA	Ground Class Gravel Road	
Latitude N 48° 08' 12"	Longitude W 123° 37' 44"	Calendar Date 4/19/14	Observer Initials DJK

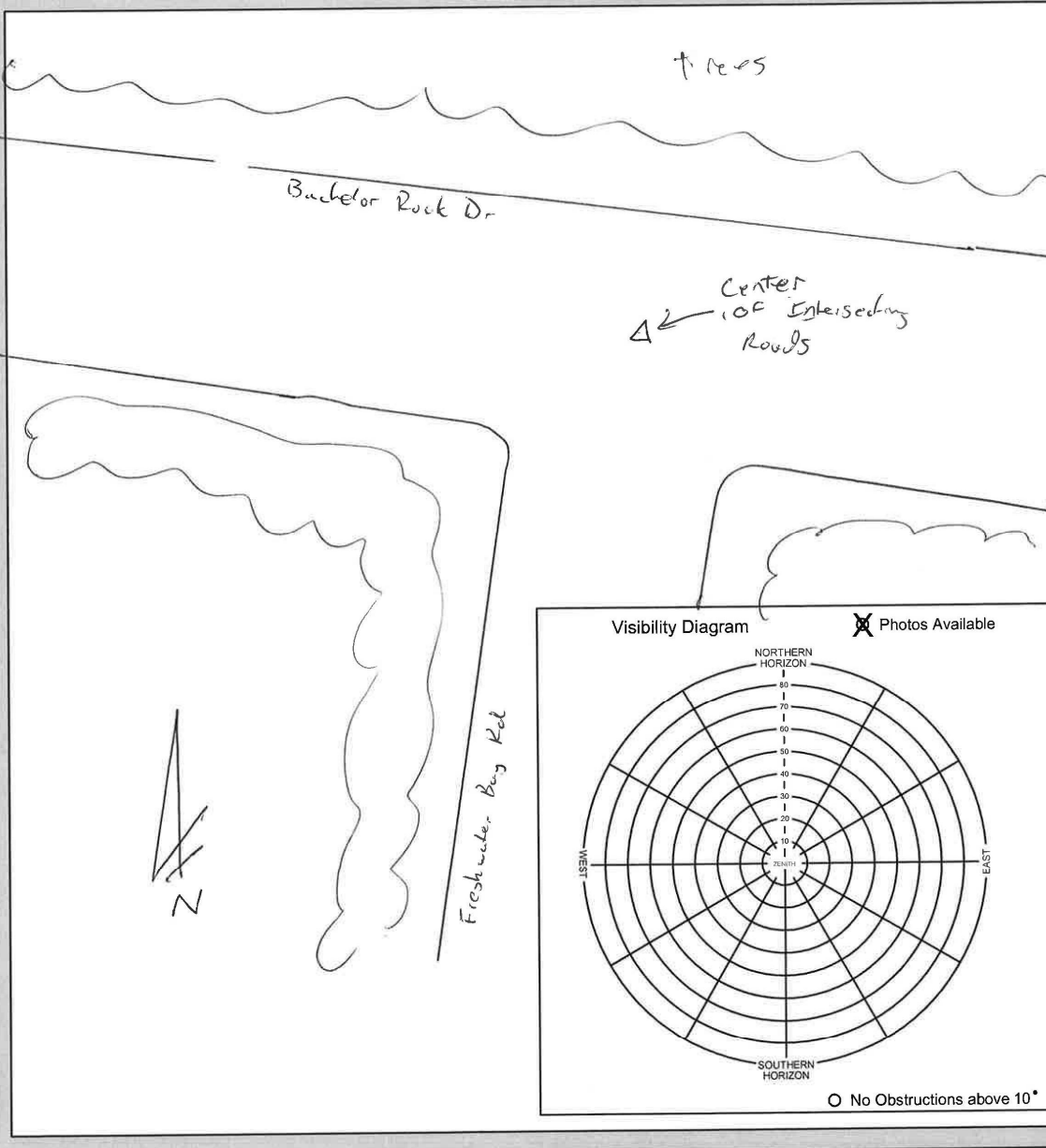



1001-E-19NOV2014

Elwah River LiDAR Survey - LiDAR Control



LiDAR Control point # <i>1002</i>	General location <i>Port Angeles, WA</i>	Ground Class <i>Gravel</i>
Latitude <i>N 48° 07' 56"</i>	Longitude <i>W 123° 35' 15"</i>	Calendar Date <i>11/19/14</i>
		Observer Initials DJK

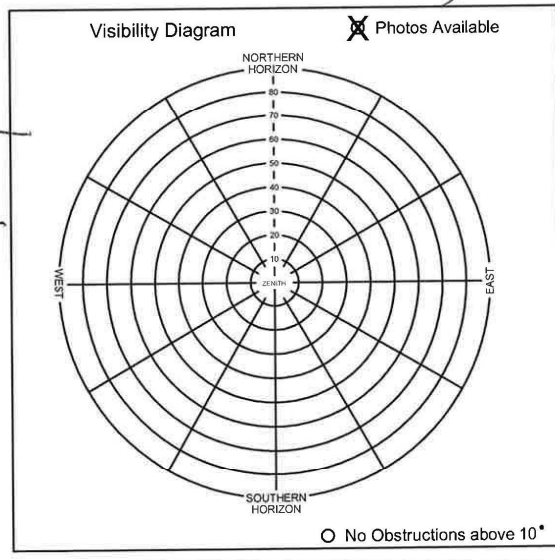
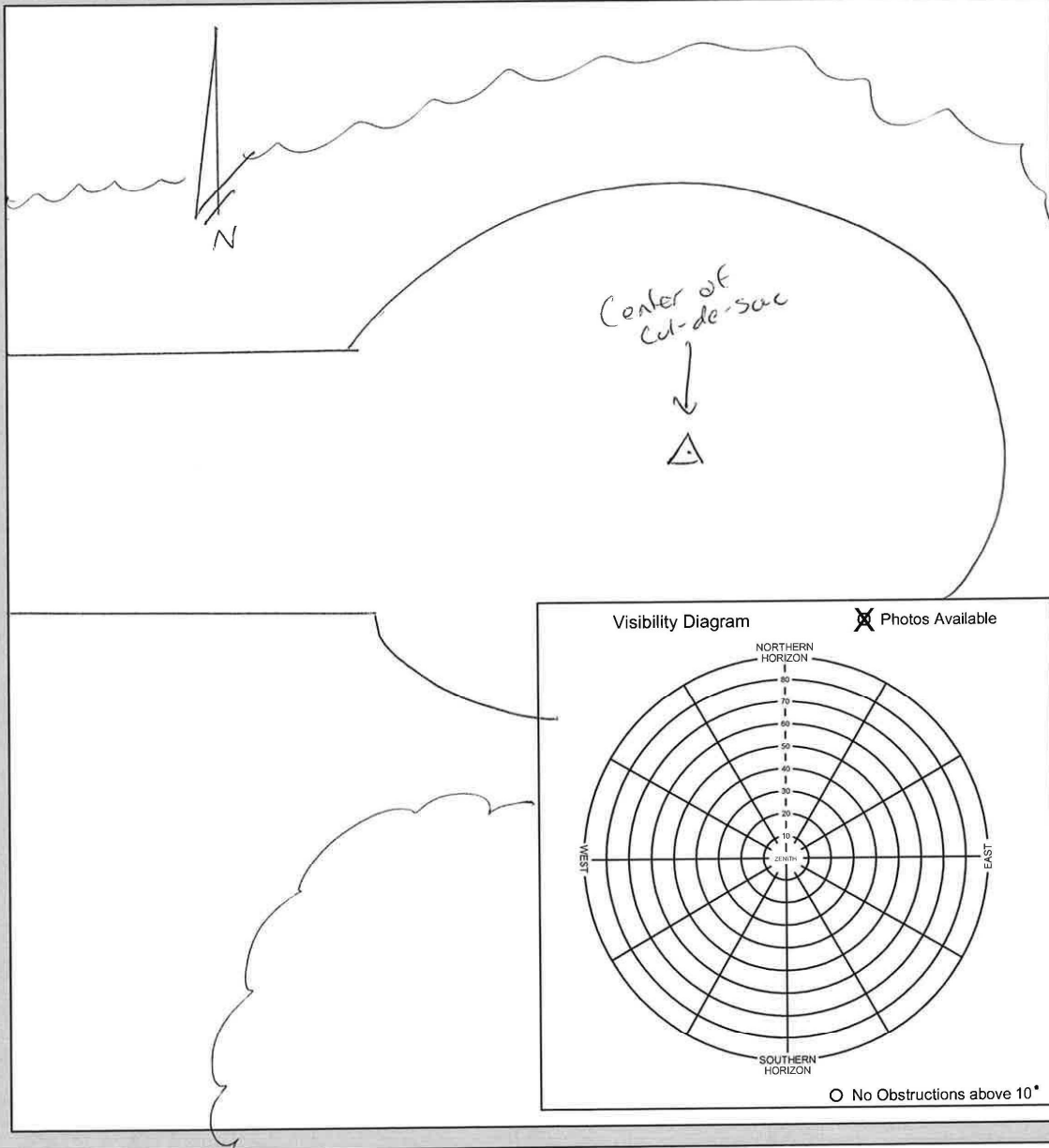



1002-W-19NOV2014

Elwah River LiDAR Survey - LiDAR Control



LiDAR Control point # 1003	General location Port Angeles, WA	Ground Class Gravel Road
Latitude N 48° 08' 51 " "	Longitude W 123° 33' 16 " "	Calendar Date 11/19/14
		Observer Initials DJK

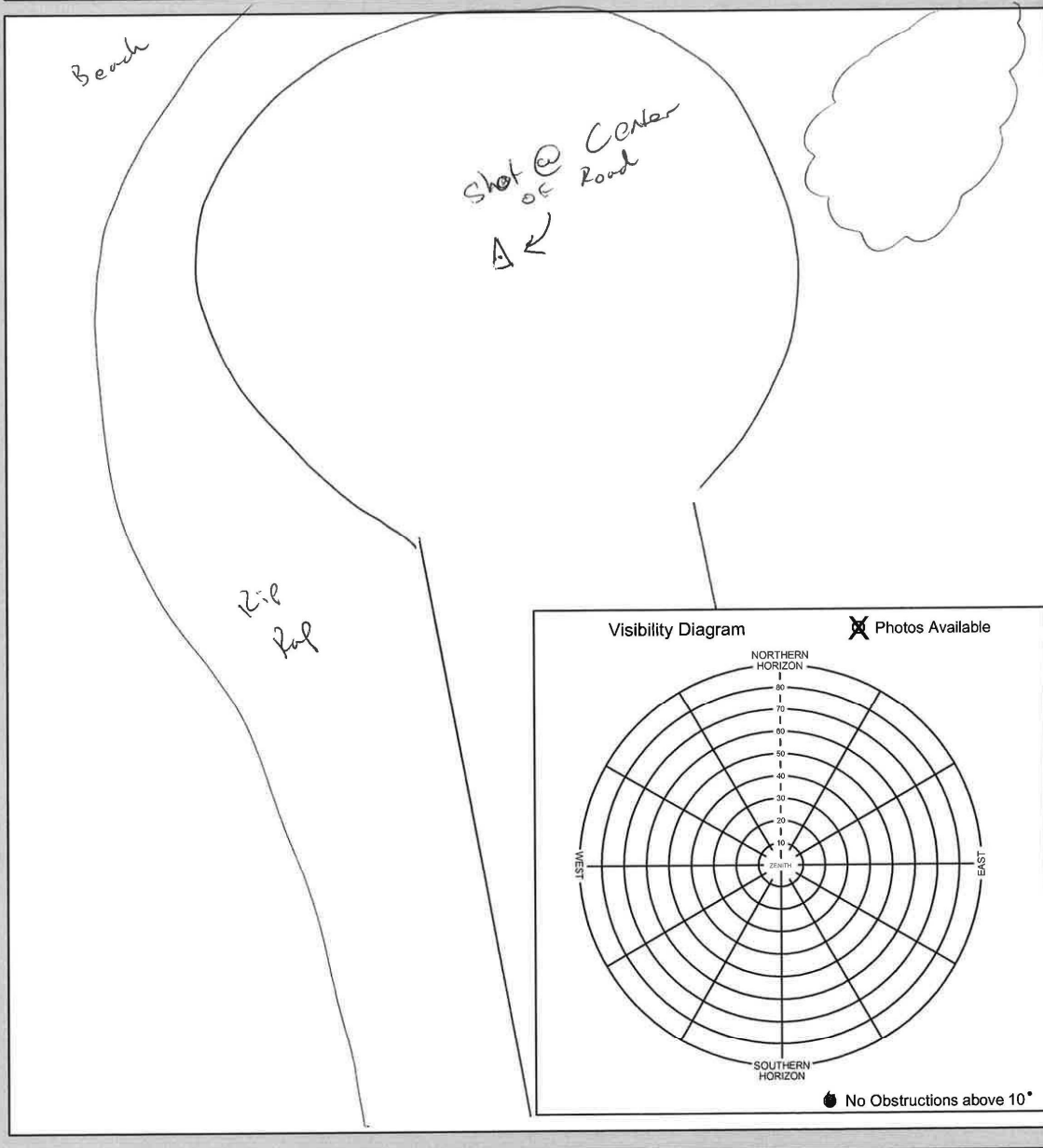



1003-N-19NOV2014

Elwah River LiDAR Survey - LiDAR Control



LiDAR Control point # 1004	General location Port Angeles, WA	Ground Class Asphalt Road
Latitude N 48° 08' 30"	Longitude W 123° 25' 35"	Calendar Date 11/19/14
		Observer Initials DJK

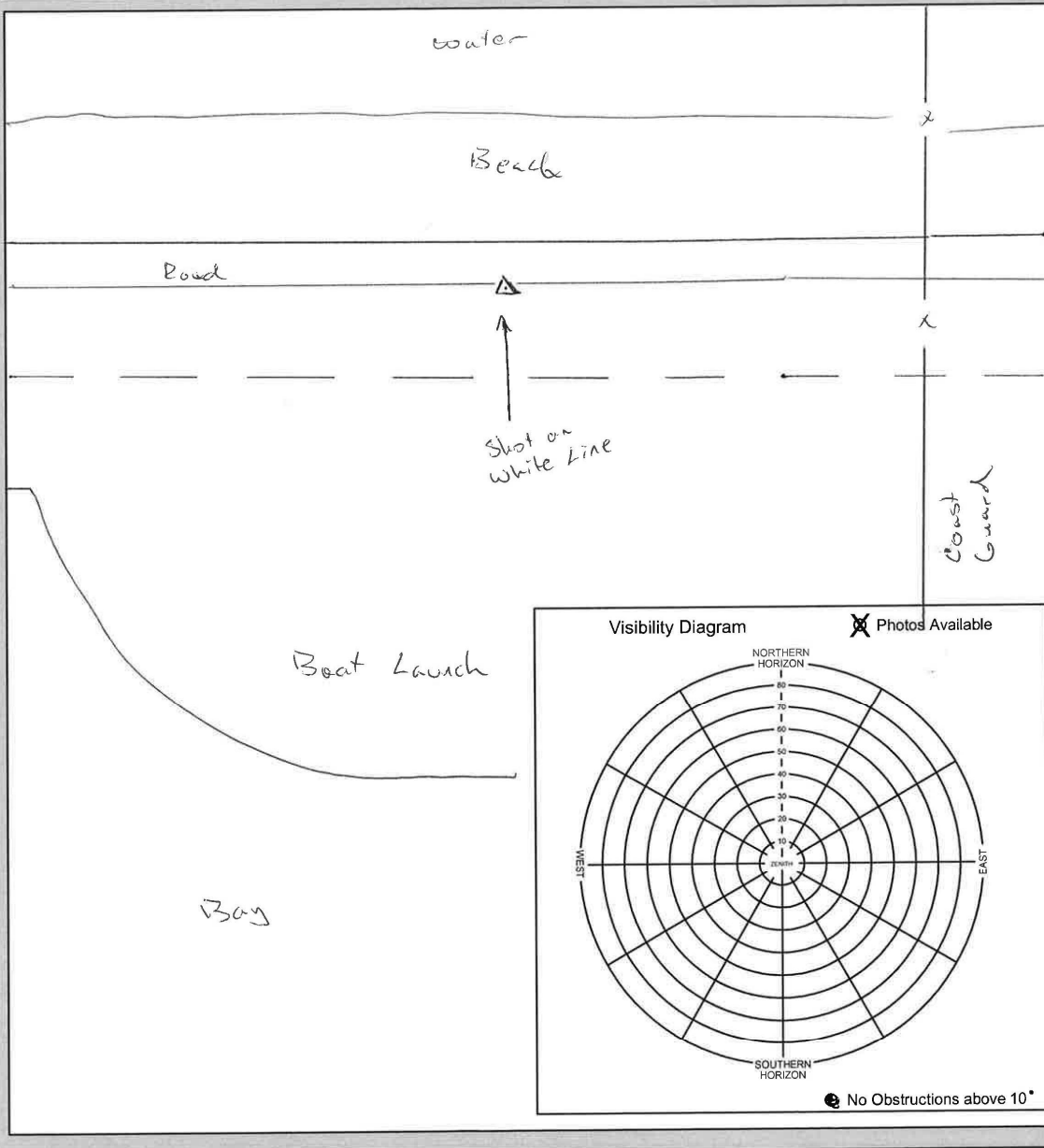



1004-S-19NOV2014

Elwah River LiDAR Survey - LiDAR Control



LiDAR Control point # 1005	General location Port Angeles, WA	Ground Class Asphalt Road
Latitude N 48° 07' 52 "	Longitude W 123° 28' 28 "	Calendar Date 11/19/14
		Observer Initials DJK

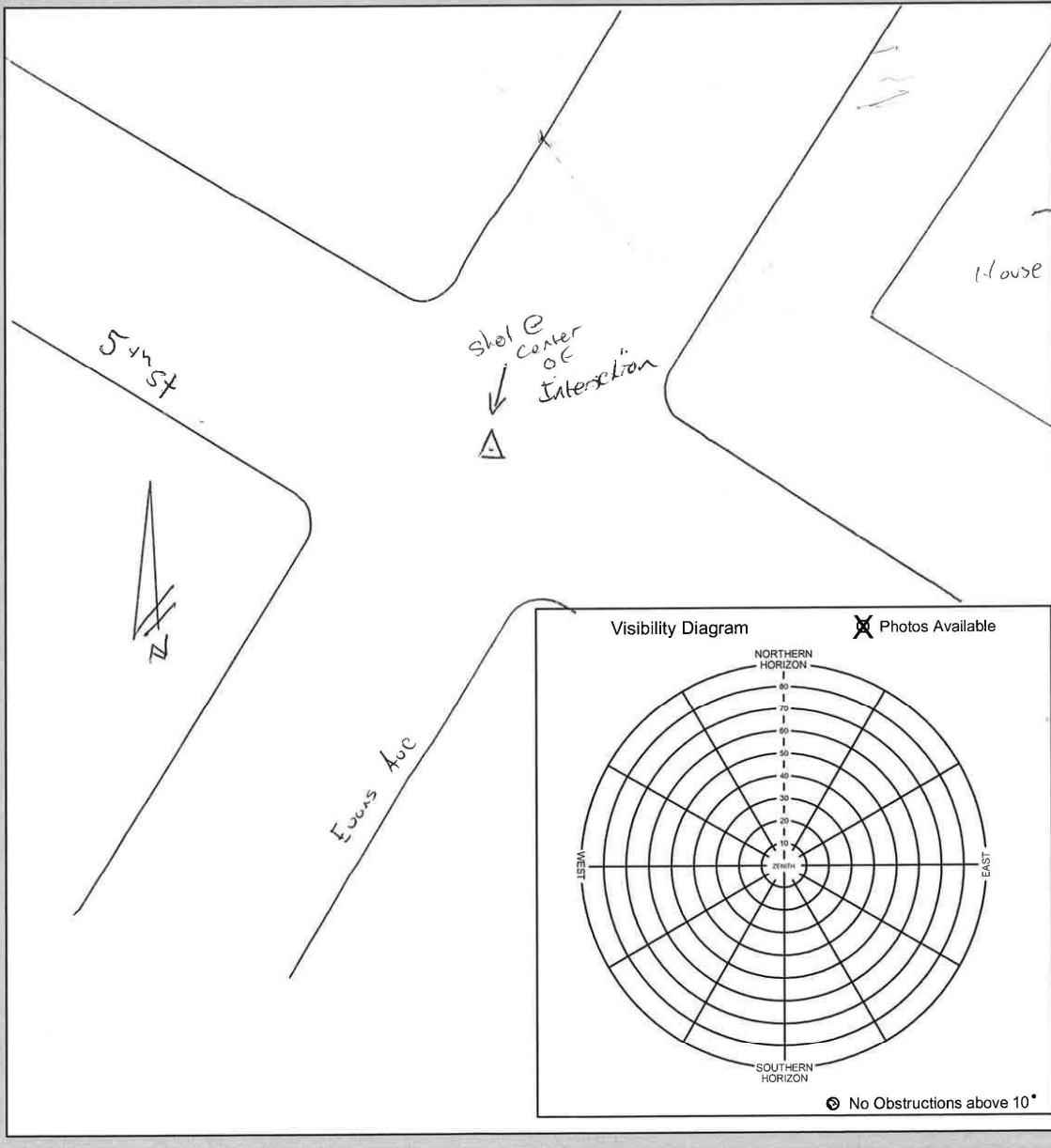



1005-S-19NOV2014

Elwah River LiDAR Survey - LiDAR Control



LiDAR Control point # 1006	General location Port Angeles WA	Ground Class Road	
Latitude N 48° 06' 59 "	Longitude W 123° 31' 57 "	Calendar Date 11/19/14	Observer Initials DJK

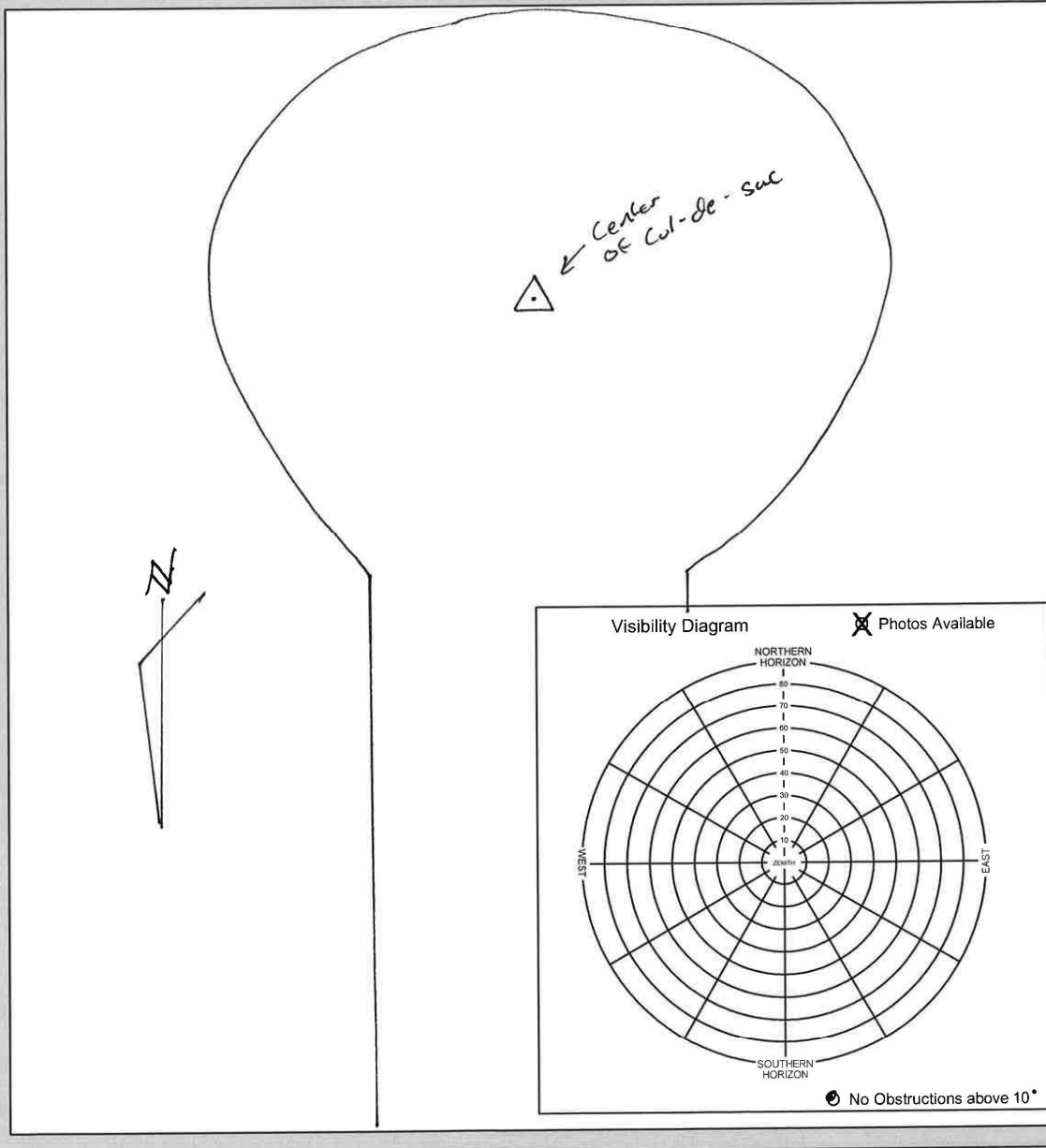



1006-S-19NOV2014

Elwah River LiDAR Survey - LiDAR Control



LiDAR Control point # 1007	General location Port Angeles, WA	Ground Class Asphalt Road
Latitude N 48° 03' 57 " "	Longitude W 123° 36' 33 " "	Calendar Date 11/19/14
		Observer Initials DJK

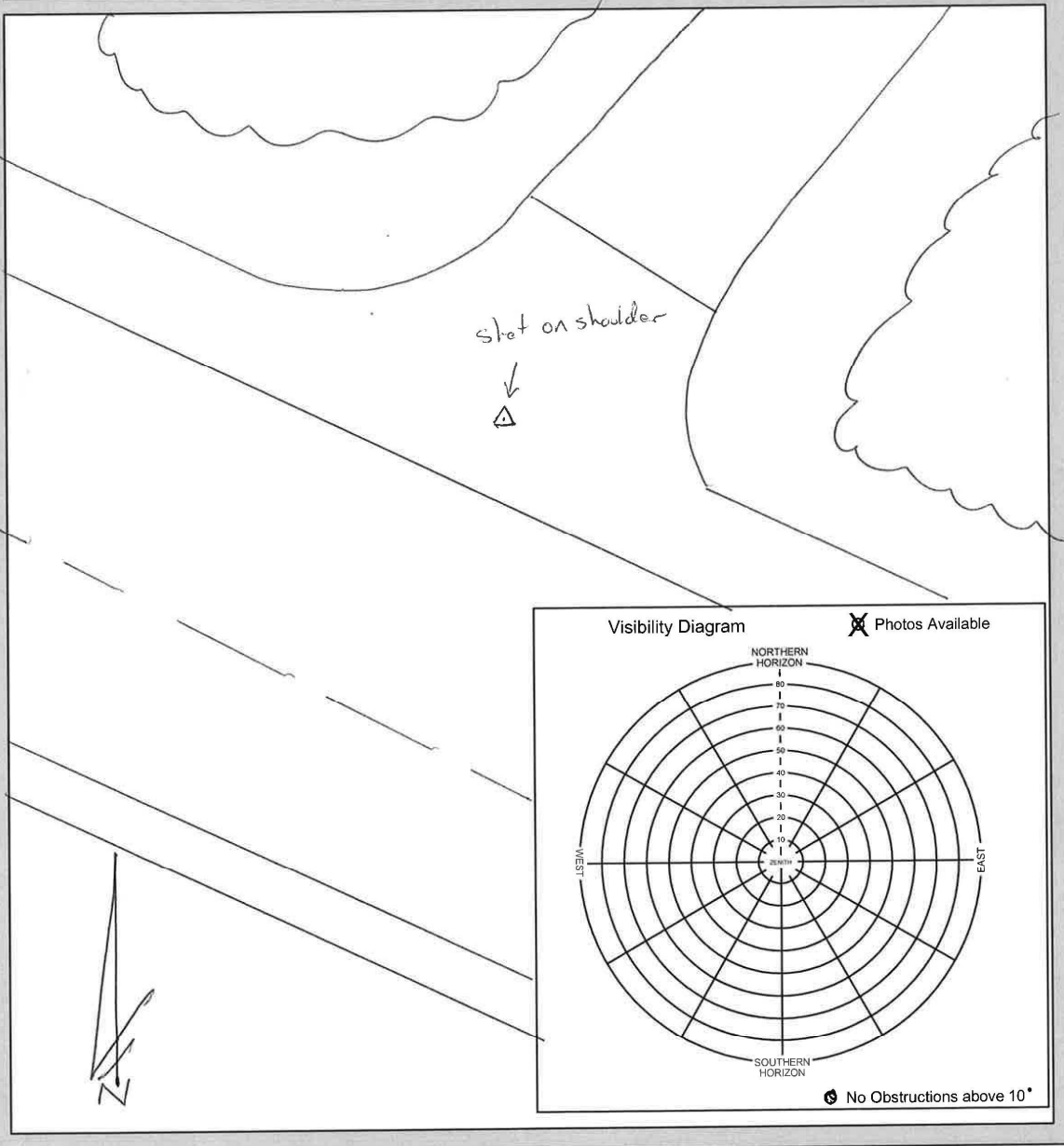



1007-W-19NOV2014

Elwah River LiDAR Survey - LiDAR Control



LiDAR Control point # 1008	General location Port Angeles WA	Ground Class Asphalt Road
Latitude N 48° 05' 11"	Longitude W 123° 43' 04"	Calendar Date 11/19/14
		Observer Initials DJK

WS 101

Lake Sutherland Rd

Shot @ SW corner of stop bar

Visibility Diagram Photos Available

NORTHERN HORIZON

SOUTHERN HORIZON

WEST EAST

No Obstructions above 10°



1008-E-20NOV2014

Elwah River LiDAR Survey - LiDAR Control



LiDAR Control point # 1009	General location Port Angeles, WA	Ground Class Asphalt Road
Latitude N 48° 04' 44 45"	Longitude W 123° 43' 36 "	Calendar Date 11/20/14
		Observer Initials DJK

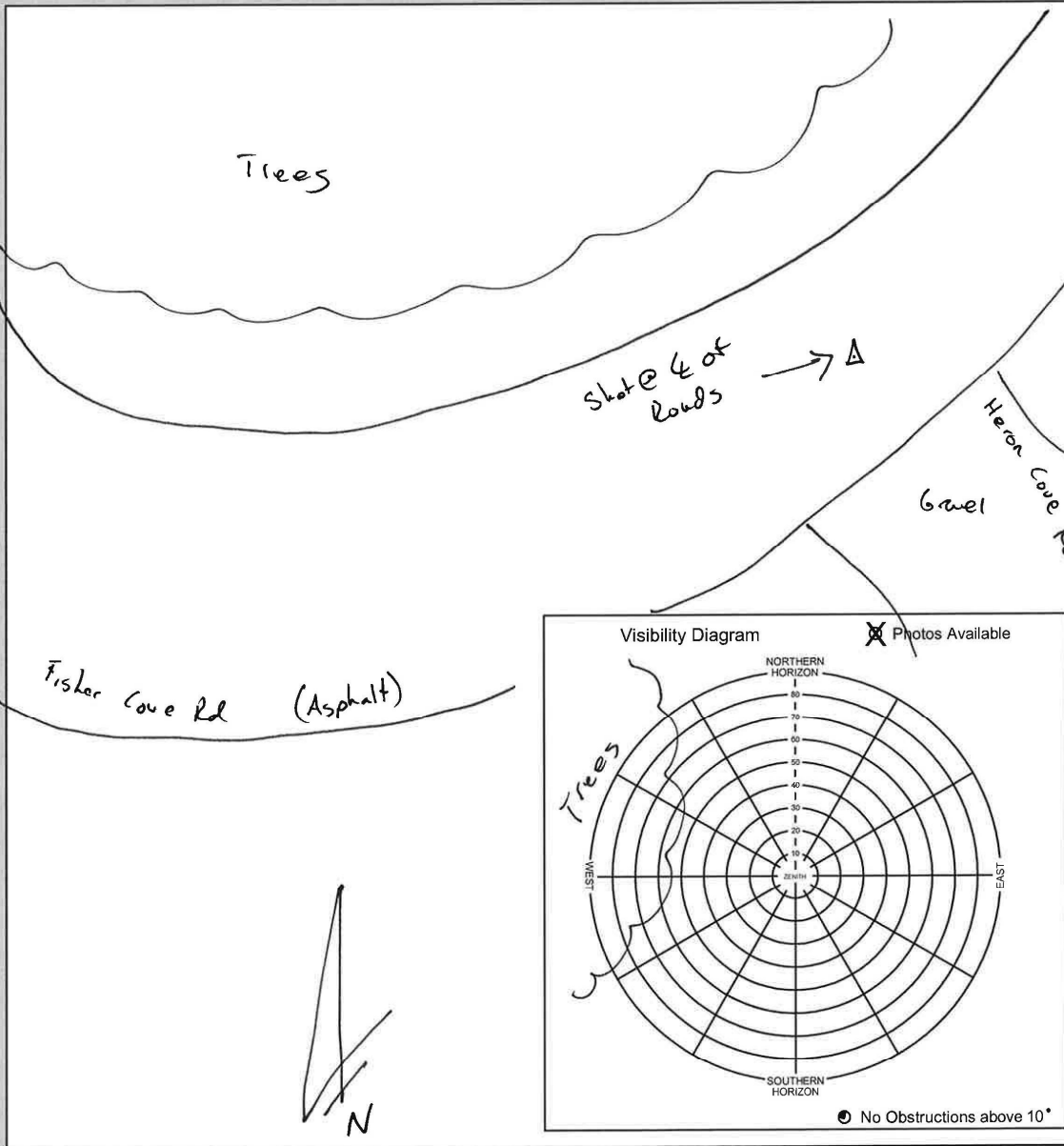



1009-E-20NOV2014

Woolpert Aeronautical Surveys - Aerial Control



Aerial Control point # 1010	General location Port Angeles, WA	Airport, LID Asphalt
Latitude N 48° 03' 39 "	Longitude W 123° 29' 36 "	Calendar Date 11/21/14
		Observer Initials DJK

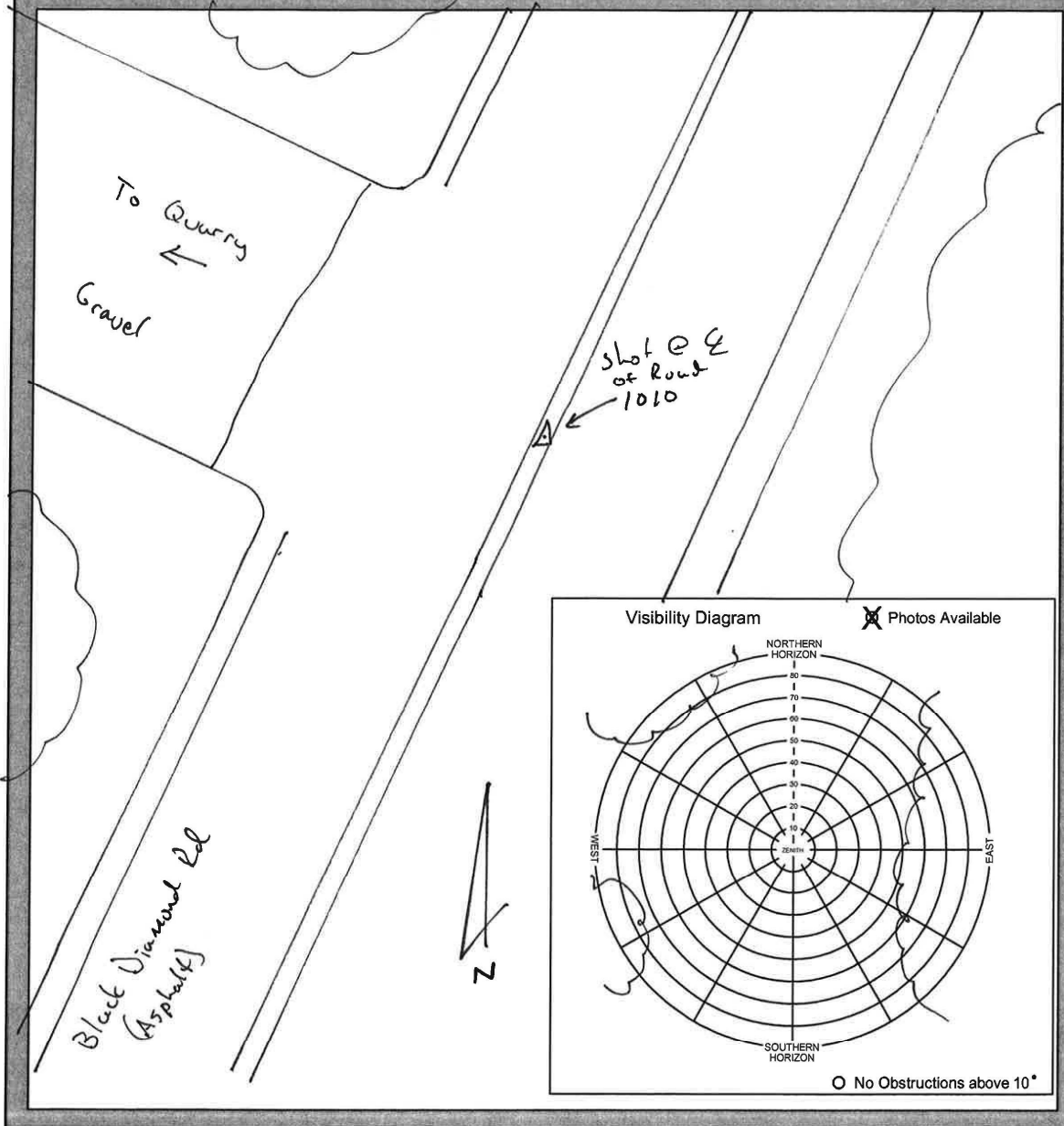



1010-N-21NOV2014

Woolpert Aeronautical Surveys - Aerial Control



Aerial Control point # <i>1011</i>	General location <i>Port Angeles, WA</i>	Airport LID <i>Asphalt Road</i>
Latitude <i>N 48° 02' 25" "</i>	Longitude <i>W 123° 25' 40" "</i>	Calendar Date <i>11/21/14</i>
		Observer Initials DJK

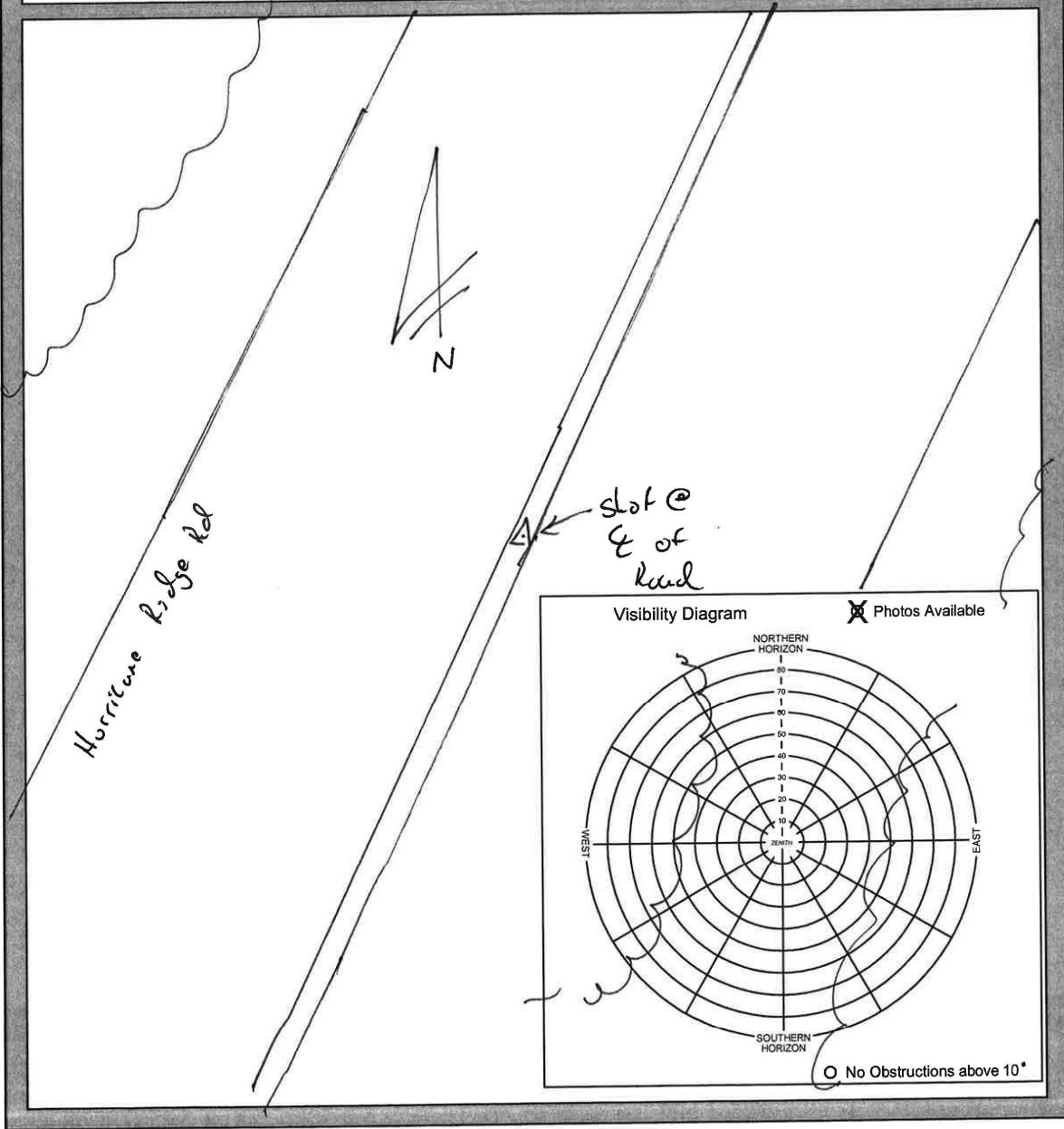



1011-S-21NOV2014

Elwah River LiDAR Survey - LiDAR Control



LiDAR Control point # 1012	General location Port Angeles, WA	Ground Class Asphalt Road
Latitude N 48° 00' 37"	Longitude W 123° 35' 25"	Calendar Date 11/20/14
		Observer Initials DJK

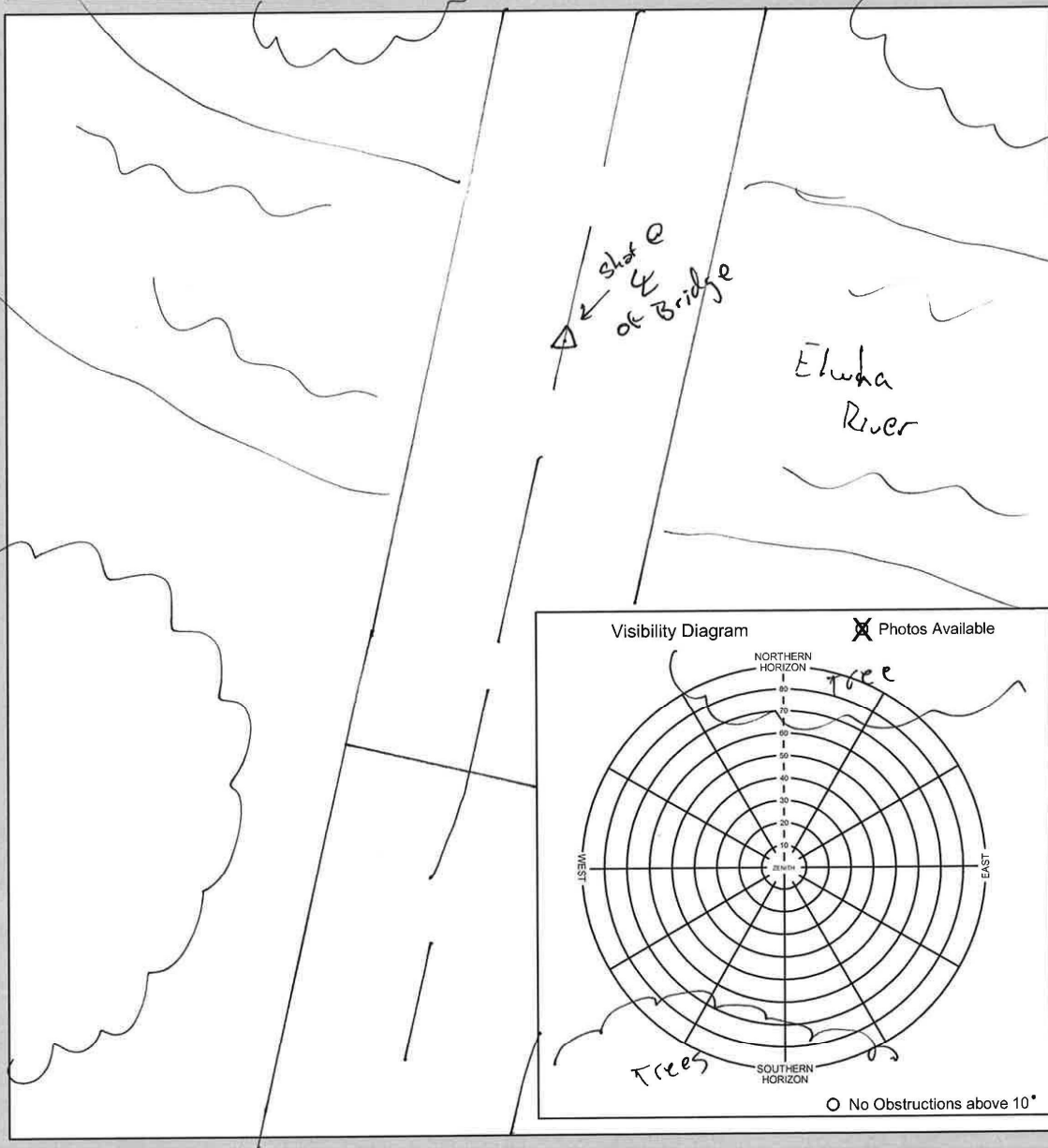



1012-N-20NOV2014

Woolpert Aeronautical Surveys - Observation Log Sheet



Station Designation 1013	Airport LID & State Elwha River	Data File Name 1013 324 0	<input type="checkbox"/> RTK File
------------------------------------	---	-------------------------------------	-----------------------------------

Observer Full Name Daniel J. Kuxhausen	Home Office Denver
Observer email daniel.kuxhausen@woolpert.com	
Observer Phone Office - 303 . 925 . 1400 Cell - 303 . 514 . 5741	

Start Time : 2 : 40 local	Stop Time : 3 : 11 local	Calendar Date 11 / 20 / 14
--	---------------------------------------	--------------------------------------

Station Classification <input type="checkbox"/> FBN <input type="checkbox"/> CBN <input type="checkbox"/> BM <input type="checkbox"/> PACS <input type="checkbox"/> SACS <input type="checkbox"/> TSM <input type="checkbox"/> EoR <input type="checkbox"/> NAVAID <input checked="" type="checkbox"/> Photo Control <input type="checkbox"/> Other:				
Station PID	Sta. SSN	Sta. ID 1013	Session 0	Julian Day 324

Latitude N 48 47 58' 06"	Longitude "W 123 ° 34 ' 58 "
Antenna Ht. (before; include add. offsets) 2.000m	E-Height

Ant. Ht. Measured To <input checked="" type="checkbox"/> Bottom of Ant. Mt. <input type="checkbox"/> Other:	Ground Plane <input type="checkbox"/> Yes <input checked="" type="checkbox"/> No
Tripod Type <input checked="" type="checkbox"/> Fixed-Ht. <input type="checkbox"/> Slip-leg <input type="checkbox"/> Fixed mount <input type="checkbox"/> Bi-pod	

Receiver P/N R8-3 S/N 5242498336	Antenna P/N R8-3 S/N 5242498336
--	---------------------------------------

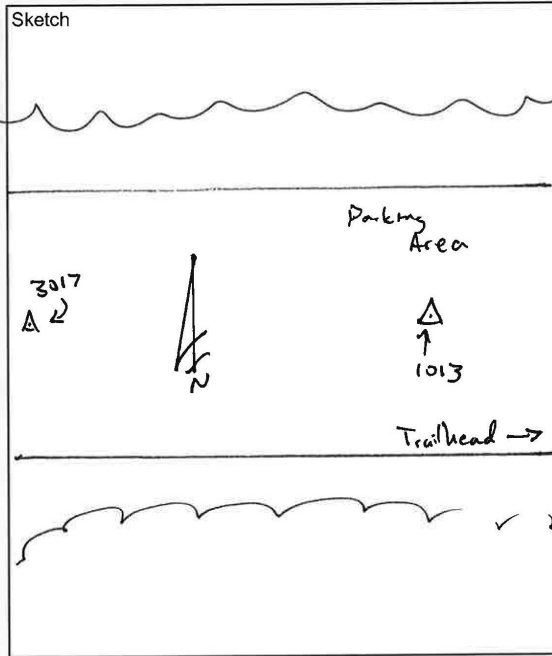

Location Description / Comments
Set in E of Parking Area

Visibility Diagram Photos Available

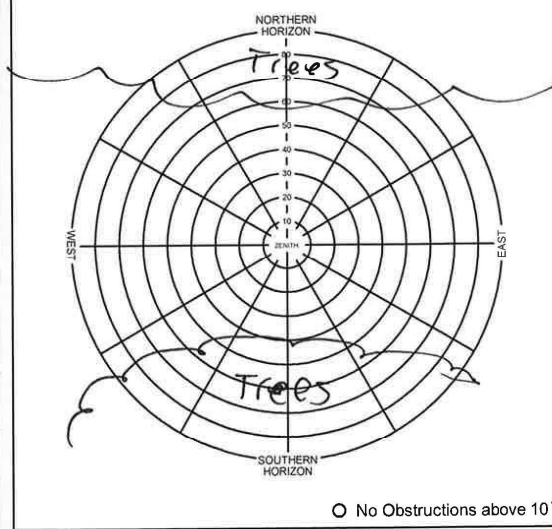

Setting Type <input type="checkbox"/> Deep Rod <input type="checkbox"/> Concrete Mon. <input type="checkbox"/> Fixed Mt.	Monument Size
Stamping	Inscription (i.e. NGS, Woolpt, etc.)
Photo Ctrl Target Type	



1013-W-20NOV2014

Woolpert Aeronautical Surveys - Aerial Control



Aerial Control point # 1014	General location Port Angeles, WA	Airport LID Asphalt Road
Latitude N 47° 58' 58" "	Longitude W 123° 36' 48" "	Calendar Date 11/20/14
		Observer Initials DJK

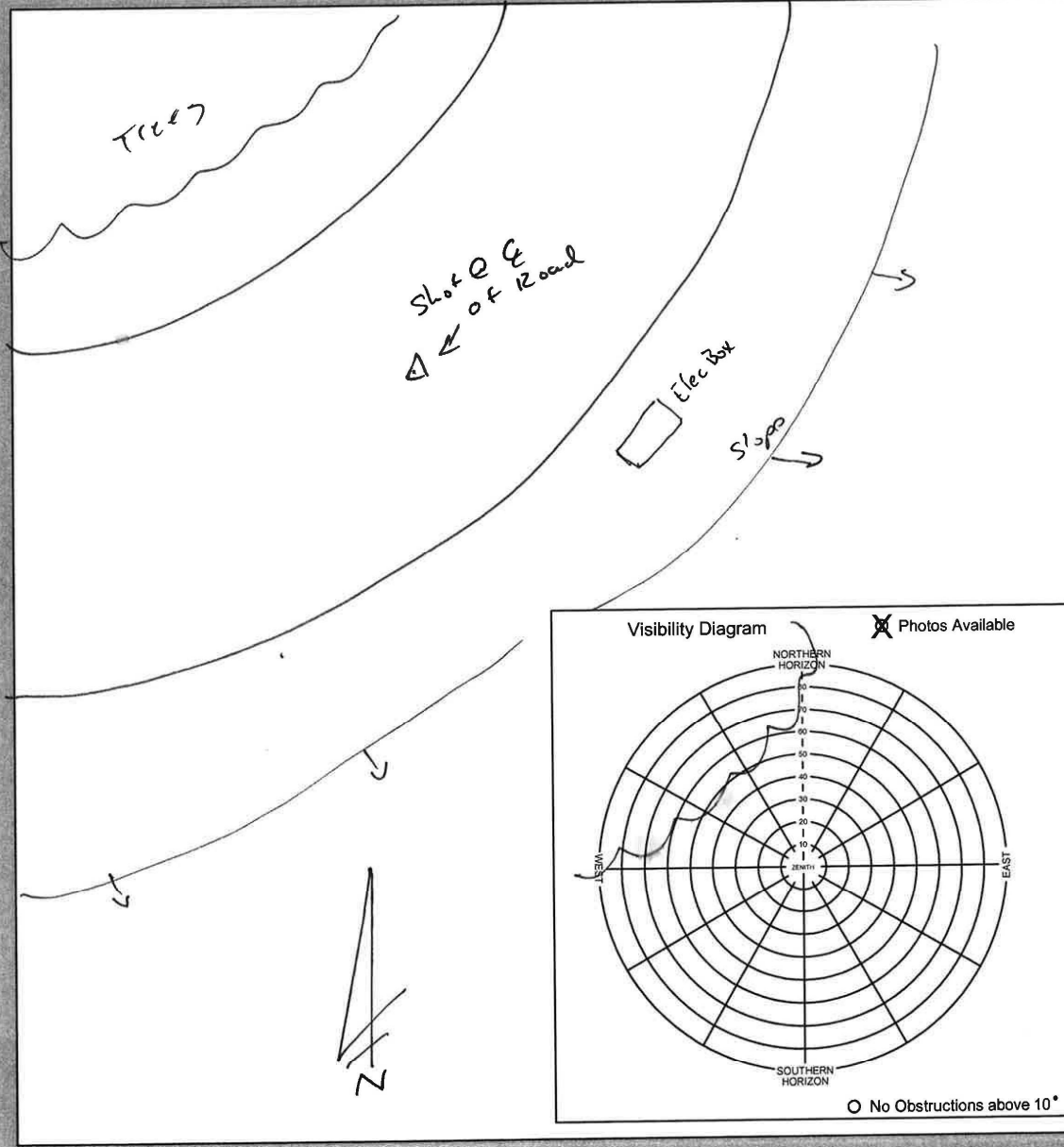



1014-W-19NOV2014

Elwah River LiDAR Survey - LiDAR Control



Aerial Control point # 1015	General location Port Angeles WA	Airport LID Asphalt Road
Latitude N 48° 02' 54" "	Longitude W 123° 36' 08" "	Calendar Date 11/20/14
		Observer Initials DJK

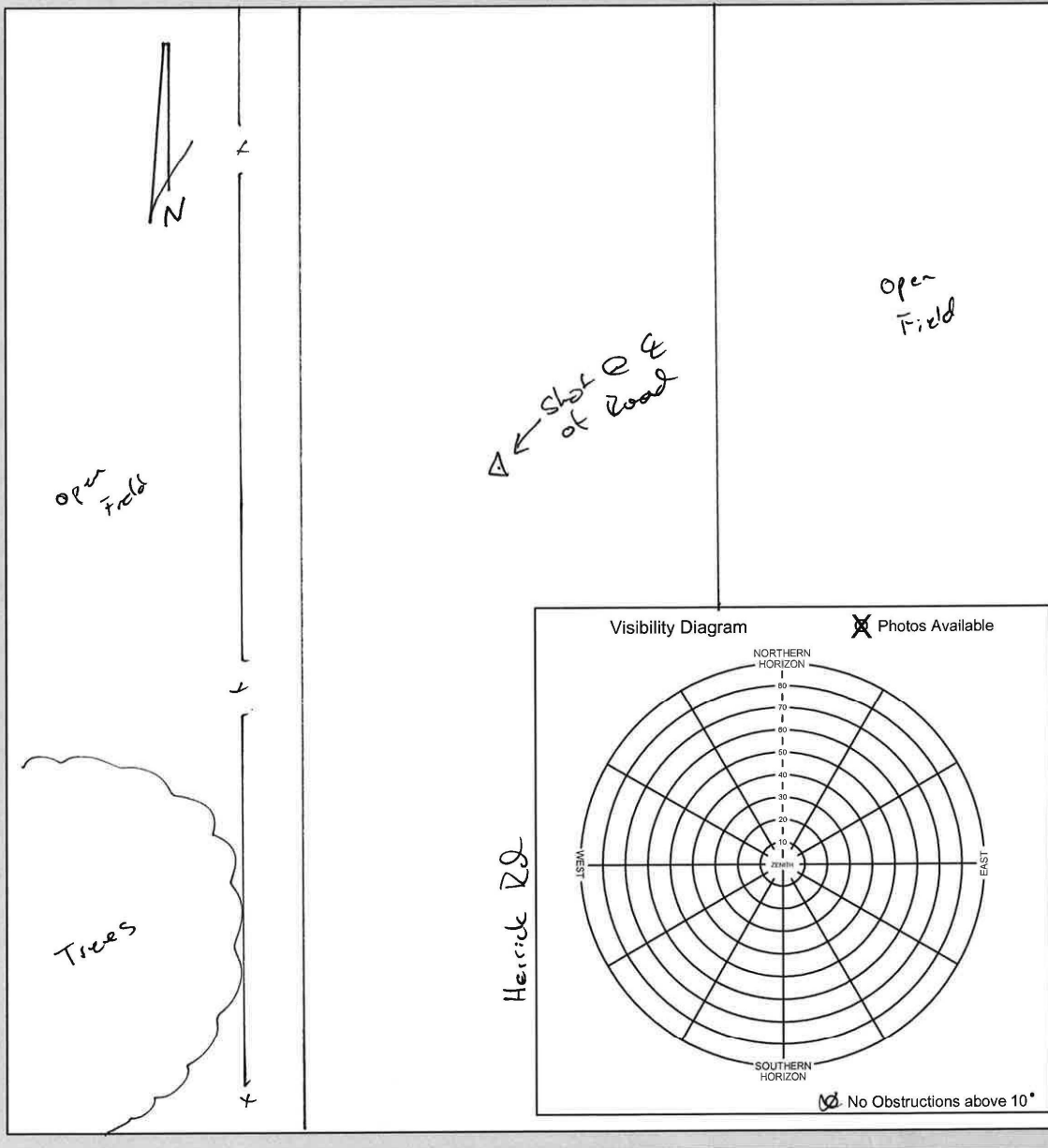



1015-W-20NOV2014



1016-E-21NOV2014

Elwah River LiDAR Survey - LiDAR Control



LiDAR Control point # 1017	General location Port Angeles, WA	Ground Class Road	
Latitude N 48° 07' 35"	Longitude W 123° 34' 15"	Calendar Date 11/19/14	Observer Initials DJK

Center of Road
⊙ Intersection

Lorilee Ln

Place Rd

Visibility Diagram Photos Available

○ No Obstructions above 10°



1017-N-19NOV2014

Elwah River LiDAR Survey - LiDAR Control



LiDAR Control point # 1018	General location Port Angeles WA	Ground Class Asphalt Road
Latitude N 48° 01' 39" "	Longitude W 123° 35' 22" "	Calendar Date 11/20/14
		Observer Initials DJK

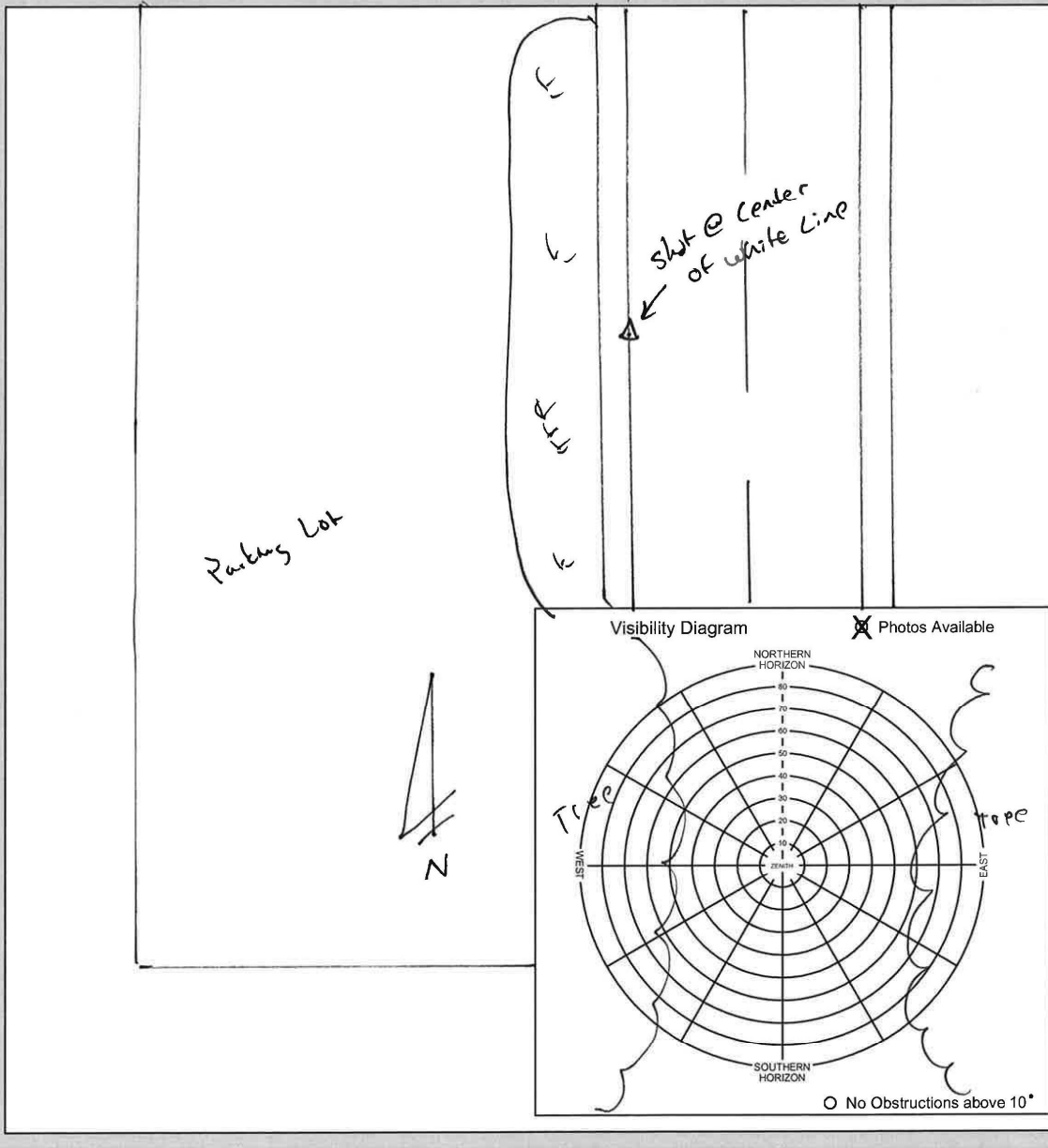



1018-S-20NOV2014

Elwah River LiDAR Survey - LiDAR Control



LiDAR Control point # 1019	General location Port Angeles, WA	Ground Class Road
Latitude N 48° 05' 57 "	Longitude W 123° 33' 14 "	Calendar Date 11/19/14
		Observer Initials DJK

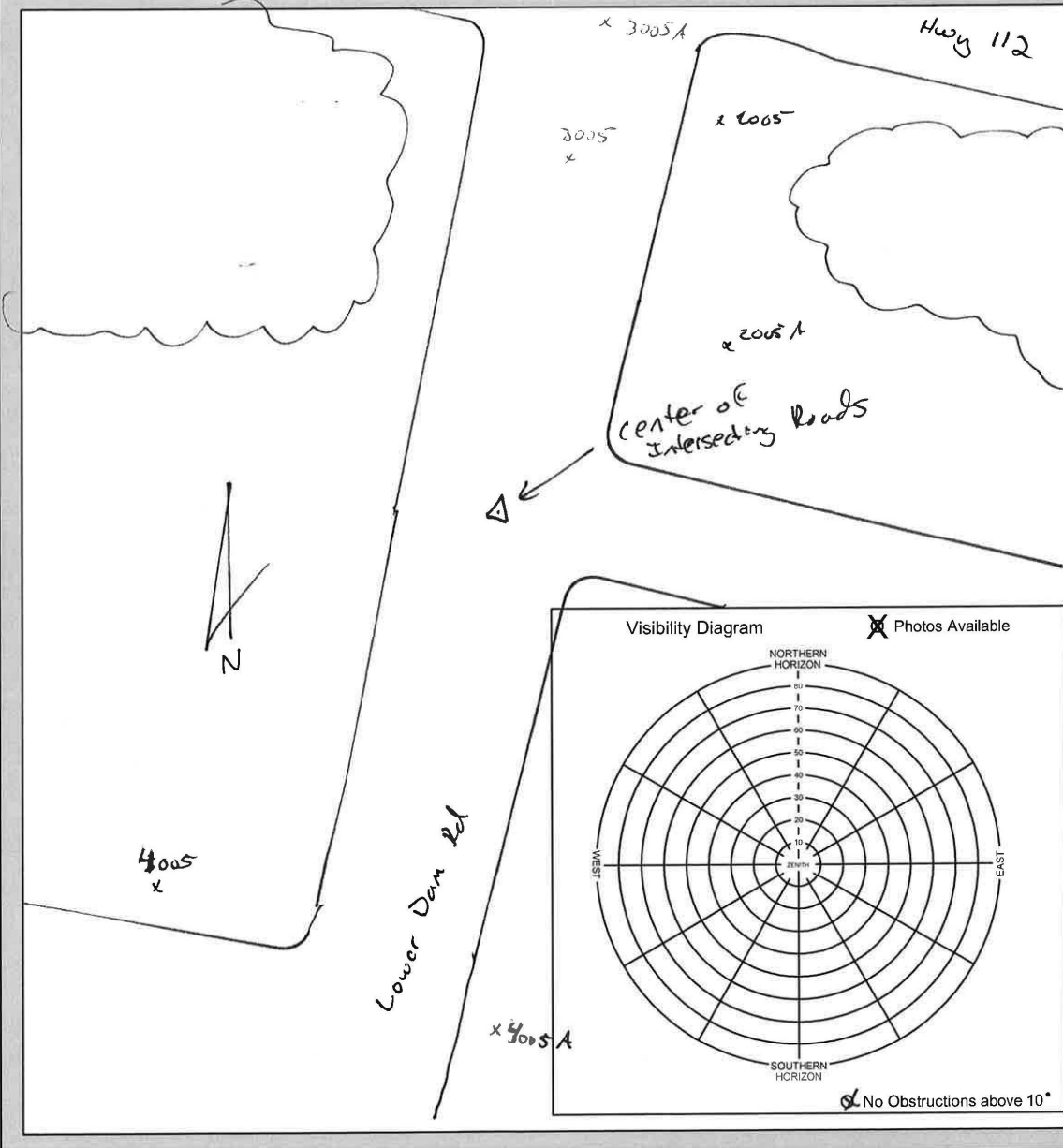



1019-S-19NOV2014

Elwah River LiDAR Survey - LiDAR Control



LiDAR Control point # 1020	General location Port Angeles, WA	Ground Class Asphalt Road	
Latitude N 48° 03' 45" "	Longitude W 123° 35' 29" "	Calendar Date 11/20/14	Observer Initials DJK

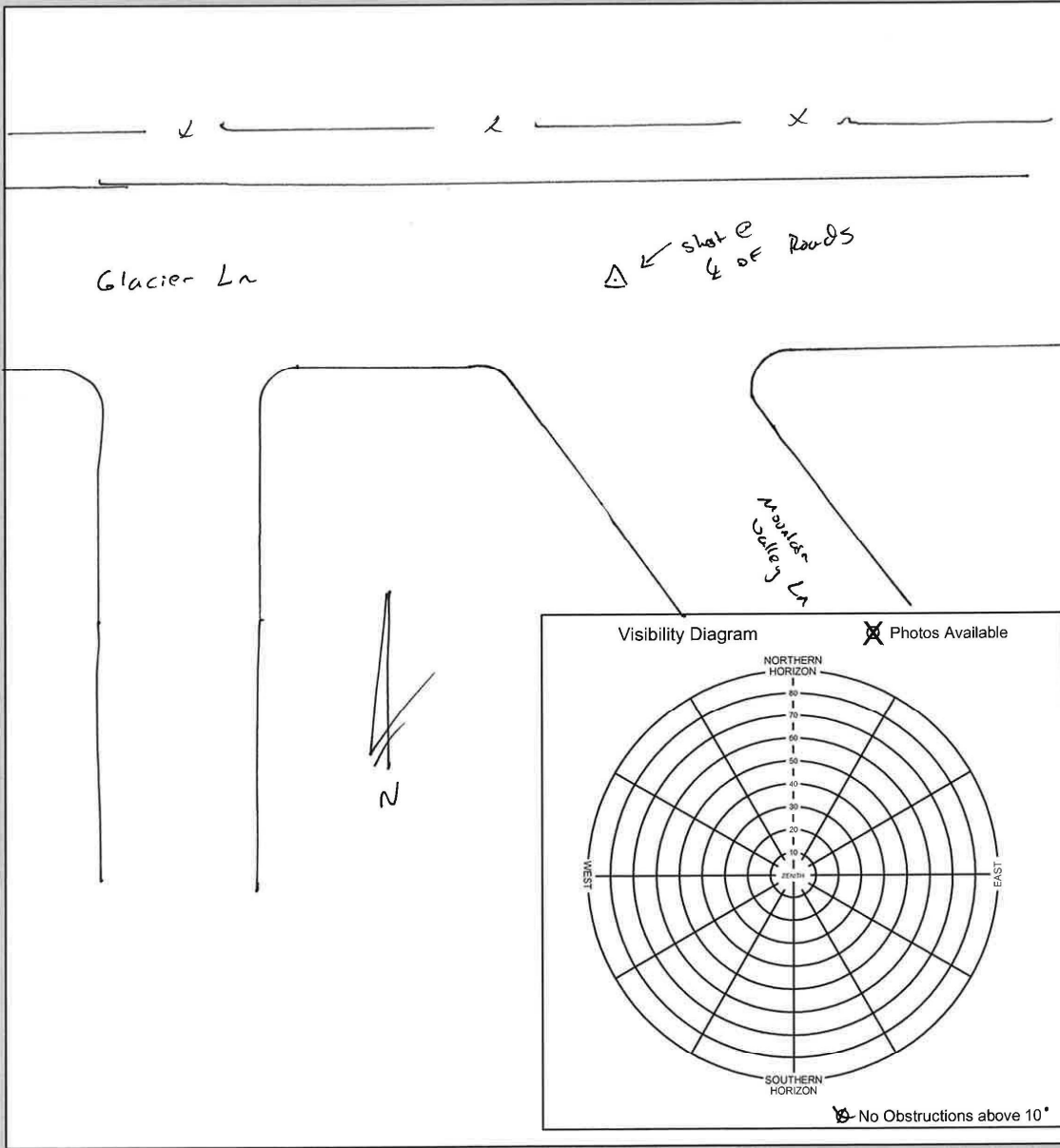



1020-E-20NOV2014

Elwah River LiDAR Survey - LiDAR Control



LiDAR Control point # 1021	General location Port Angeles, WA	Ground Class Dirt Road
Latitude N 48° 05' 22"	Longitude W 123° 41' 21"	Calendar Date 11/20/14
		Observer Initials DJK

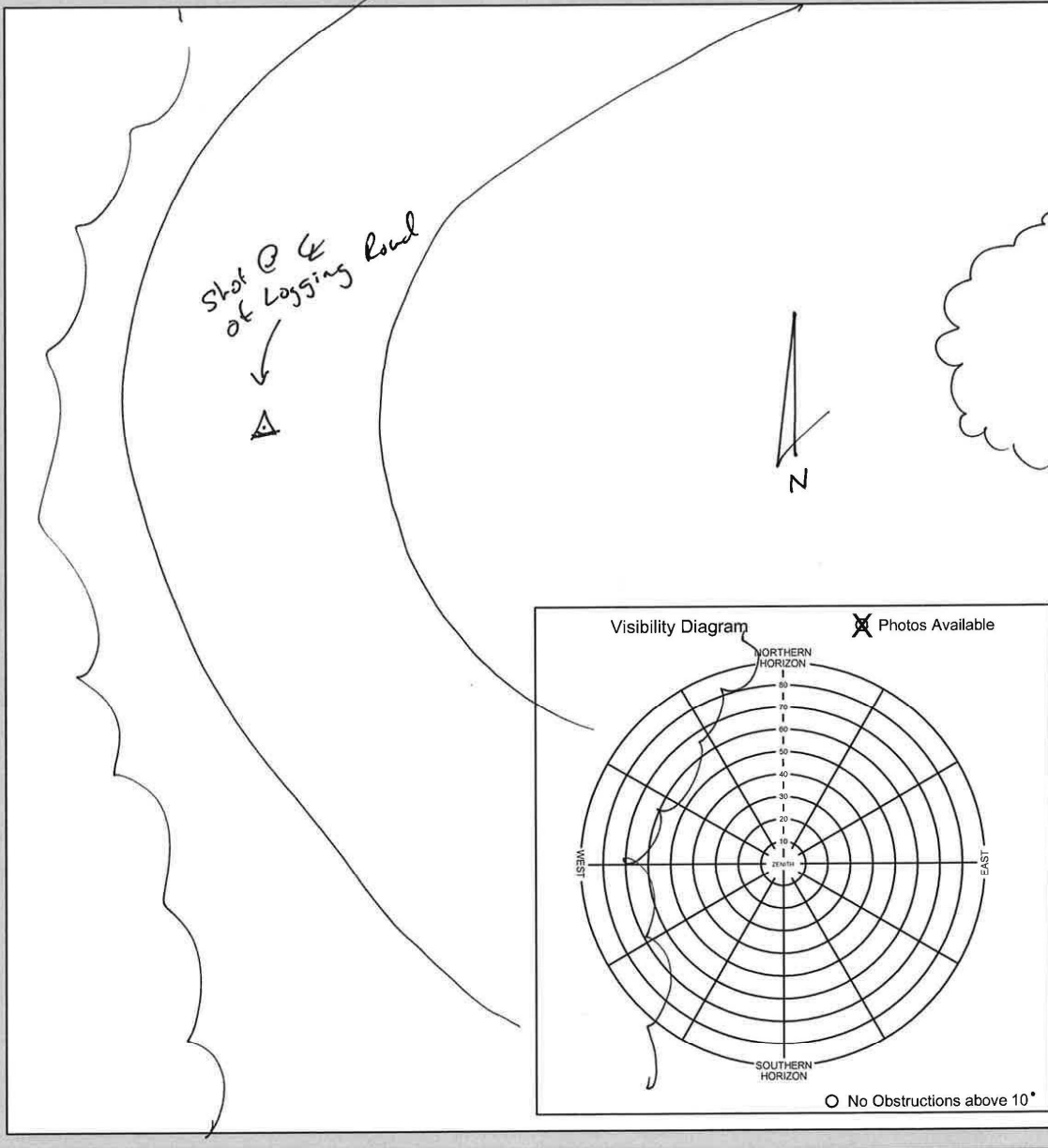



1021-S-20NOV2014

Elwah River LiDAR Survey - LiDAR Control



LiDAR Control point # 1022	General location Port Angeles, WA	Ground Class Gravel Road
Latitude N 48° 05' 27"	Longitude W 123° 43' 42"	Calendar Date 11/20/14
		Observer Initials DJK

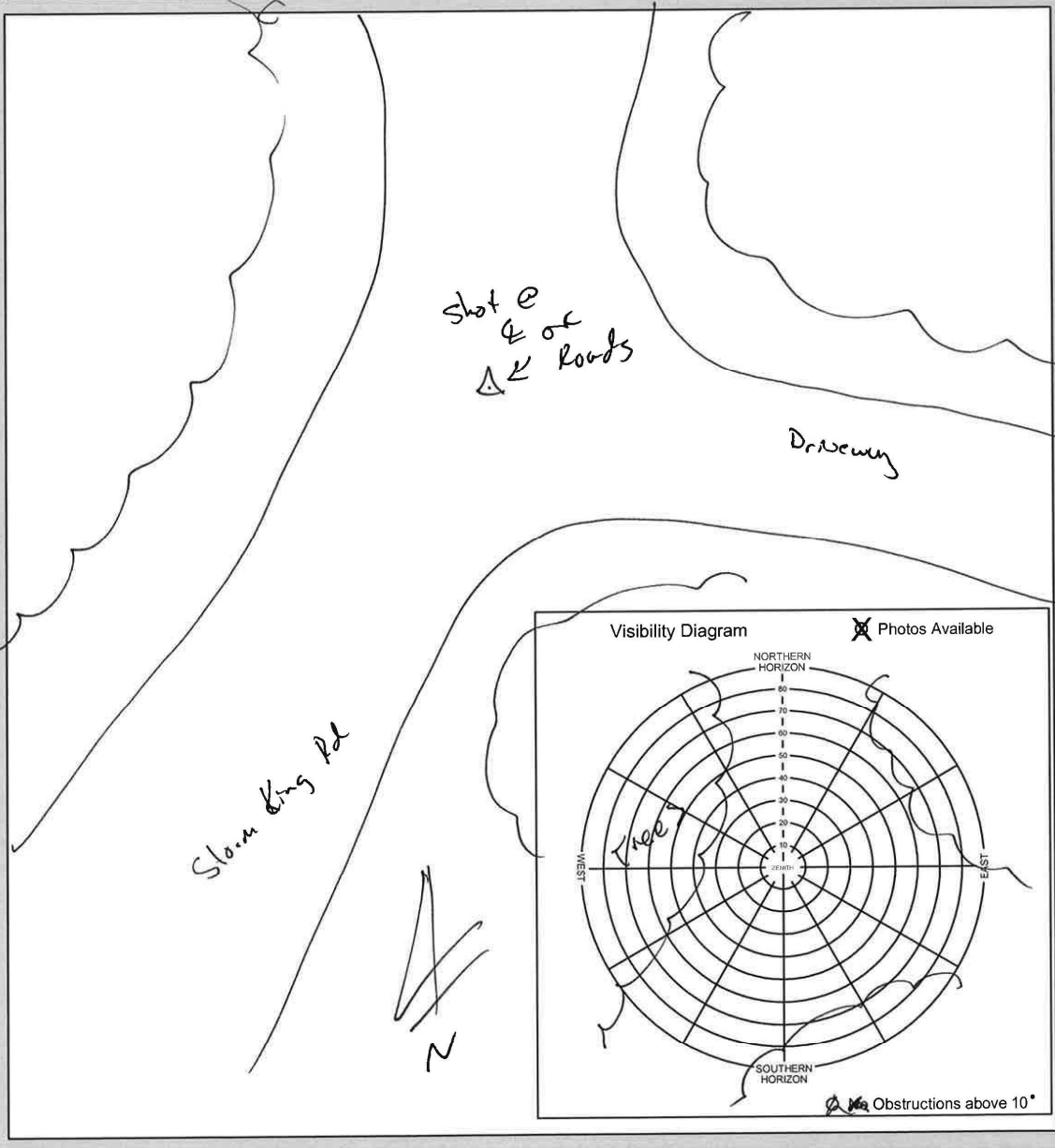



1022-S-20NOV2014

Elwah River LiDAR Survey - LiDAR Control



LiDAR Control point # 6023	General location Port Angeles, WA	Ground Class Gravel Road
Latitude N 44° 04' 17"	Longitude W 123° 42' 06"	Calendar Date 11/20/14
		Observer Initials DJK

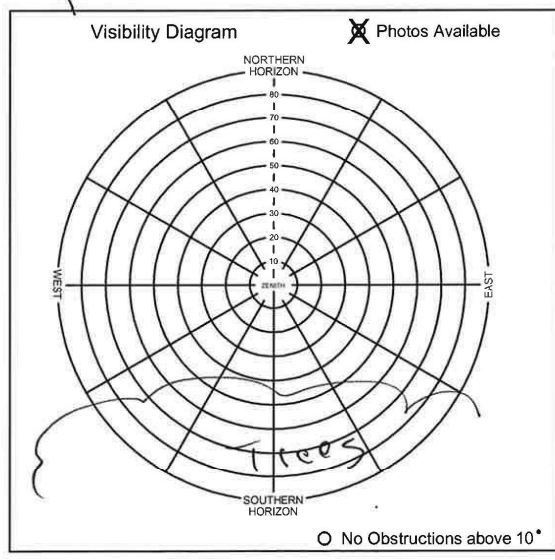
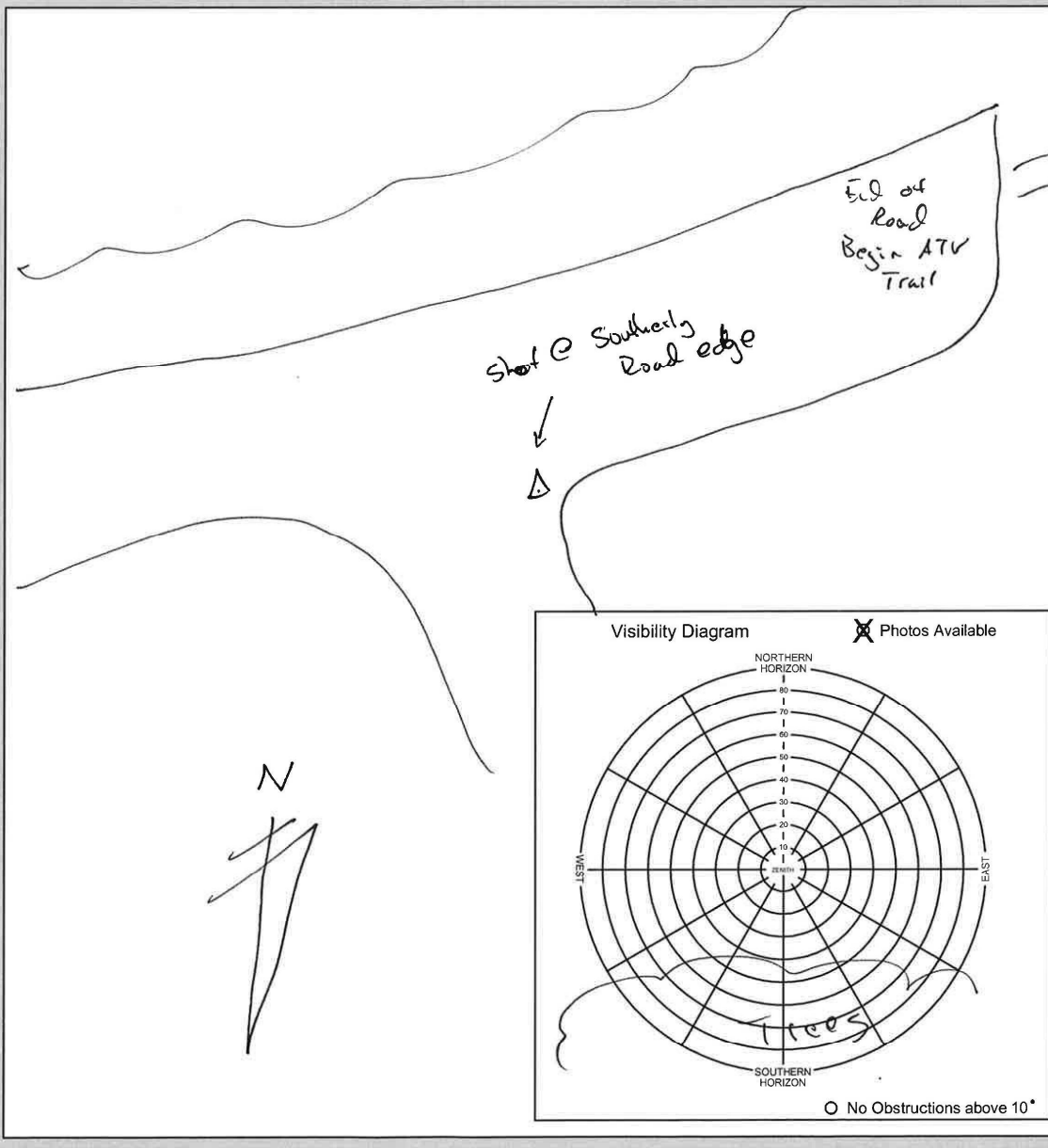



1023-N-20NOV2014

Elwah River LiDAR Survey - LiDAR Control



LiDAR Control point # 1024	General location Port Angeles	Ground Class Dist Road
Latitude N 48° 04' 21"	Longitude W 123° 42' 14"	Calendar Date 11/20/14
		Observer Initials DJK

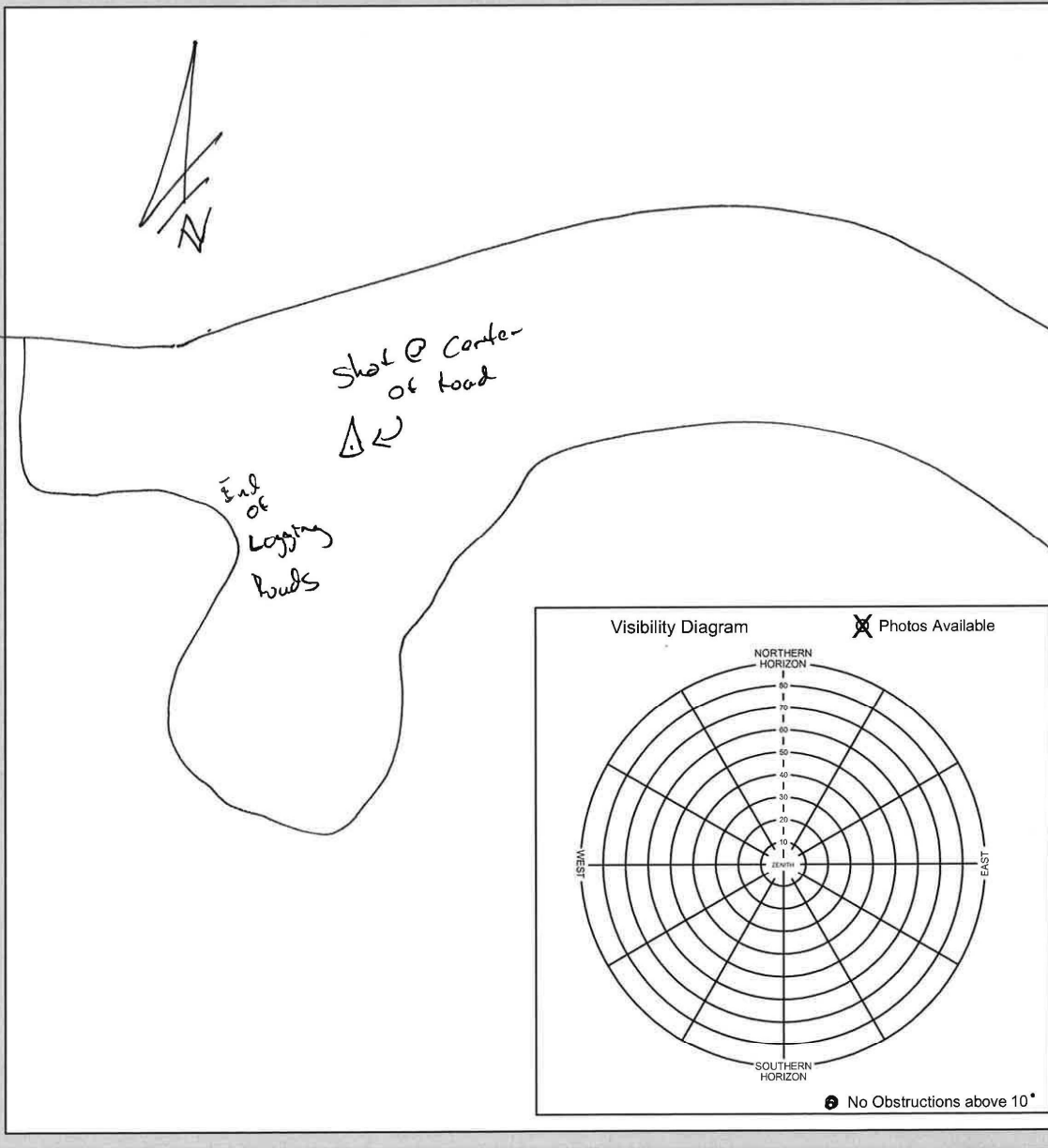



1024-W-20NOV2014

SECTION 5: EXISTING NGS DATA SHEETS

This section contains the published National Geodetic Survey (NGS) Data Sheets used in the final control network for this project.

THE NGS DATA SHEET

See file [dsdata.txt](#) for more information about the datasheet.

```
PROGRAM = datasheet95, VERSION = 8.5
1      National Geodetic Survey, Retrieval Date = NOVEMBER 26, 2014
TR2551 *****
TR2551 TIDAL BM - This is a Tidal Bench Mark.
TR2551 DESIGNATION - 944 4090 A TIDAL
TR2551 PID - TR2551
TR2551 STATE/COUNTY- WA/CLALLAM
TR2551 COUNTRY - US
TR2551 USGS QUAD - PORT ANGELES (1985)
TR2551
TR2551 *CURRENT SURVEY CONTROL
TR2551
TR2551* NAD 83(2011) POSITION- 48 07 25.14828(N) 123 27 04.01731(W) ADJUSTED
TR2551* NAD 83(2011) ELLIP HT- -16.121 (meters) (06/27/12) ADJUSTED
TR2551* NAD 83(2011) EPOCH - 2010.00
TR2551* NAVD 88 ORTHO HEIGHT - 4.069 (meters) 13.35 (feet) ADJUSTED
TR2551
TR2551 NAD 83(2011) X - -2,351,240.348 (meters) COMP
TR2551 NAD 83(2011) Y - -3,558,930.275 (meters) COMP
TR2551 NAD 83(2011) Z - 4,726,053.229 (meters) COMP
TR2551 LAPLACE CORR - -6.15 (seconds) DEFLEC12A
TR2551 GEOID HEIGHT - -20.24 (meters) GEOID12A
TR2551 DYNAMIC HEIGHT - 4.070 (meters) 13.35 (feet) COMP
TR2551 MODELED GRAVITY - 980,864.9 (mgal) NAVD 88
TR2551
TR2551 VERT ORDER - SECOND CLASS I
TR2551
TR2551 FGDC Geospatial Positioning Accuracy Standards (95% confidence, cm)
TR2551 Type Horiz Ellip Dist(km)
TR2551 -----
TR2551 NETWORK 3.09 6.19
TR2551 -----
TR2551 MEDIAN LOCAL ACCURACY AND DIST (015 points) 3.90 7.64 83.03
TR2551 -----
TR2551 NOTE: Click here for information on individual local accuracy
TR2551 values and other accuracy information.
TR2551
TR2551
TR2551.The horizontal coordinates were established by GPS observations
TR2551.and adjusted by the National Geodetic Survey in June 2012.
TR2551
TR2551.NAD 83(2011) refers to NAD 83 coordinates where the reference
TR2551.frame has been affixed to the stable North American tectonic plate. See
TR2551.NA2011 for more information.
TR2551
TR2551.The horizontal coordinates are valid at the epoch date displayed above
TR2551.which is a decimal equivalence of Year/Month/Day.
TR2551
TR2551.The orthometric height was determined by differential leveling and
TR2551.adjusted by the NATIONAL GEODETIC SURVEY
TR2551.in December 2012.
TR2551
TR2551.This Tidal Bench Mark is designated as VM 1118
TR2551.by the CENTER FOR OPERATIONAL OCEANOGRAPHIC PRODUCTS AND SERVICES.
```

TR2551'DESCRIBED BY NATIONAL GEODETIC SURVEY 1987 (MRM)
 TR2551'THE STATION WAS RECOVERED AT THIS DATE.
 TR2551'
 TR2551'THE STATION IS LOCATED AT PORT ANGELES.
 TR2551'
 TR2551'TO REACH THE STATION FROM THE INTERSECTION OF LINCOLN STREET AND
 TR2551'FRONT STREET IN PORT ANGELES, GO WEST FOR 0.6 KM (0.4 MI) ON FRONT
 TR2551'STREET TO A FORK.
 TR2551'FOLLOW THE RIGHT FORK AND GO WEST FOR 1.05 KM (0.65 MI) ON MARINE
 TR2551'DRIVE TO A FIRE HYDRANT AND POWER POLE NUMBER 125 ON THE RIGHT AND
 TR2551'THE STATION.
 TR2551'
 TR2551'THE STATION IS A STANDARD NOS DISK
 TR2551'STAMPED---4090A 1981---,
 TR2551'CRIMPED TO THE TOP OF A GALVANIZED STEEL ROD ENCASED IN A 4-INCH
 TR2551'PVC PIPE. LOCATED
 TR2551'13.6 METERS (44.5 FT) SOUTH-SOUTHWEST FROM THE SOUTHWEST RAIL OF
 TR2551'RAILROAD,
 TR2551'2.6 METERS (8.5 FT) EAST-SOUTHEAST FROM A FIRE HYDRANT AND
 TR2551'2.3 METERS (7.5 FT) WEST-NORTHWEST FROM POWER POLE NUMBER 125
 TR2551'WITH A WITNESS POST.
 TR2551'
 TR2551'WASHINGTON DOT, FAA, TIDE STATIONS - 1987.
 TR2551'
 TR2551'THIS STATION SUITABLE FOR GPS SURVEYS.
 TR2551'
 TR2551'DESCRIBED BY D.A. WEGENAST.
 TR2551'
 TR2551'
 TR2551' STATION RECOVERY (1988)
 TR2551'
 TR2551'RECOVERED 1988
 TR2551'RECOVERED IN GOOD CONDITION.
 TR2551'
 TR2551'
 TR2551' STATION RECOVERY (1989)
 TR2551'
 TR2551'
 TR2551'RECOVERY NOTE BY NATIONAL GEODETIC SURVEY 1989
 TR2551'THE STATION IS LOCATED ABOUT 41.8 KM (26.0 MI) SOUTH OF VICTORIA, 27.4
 TR2551'KM (17.0 MI) WEST OF SEQUIM, 24.1 KM (15.0 MI) EAST OF JOYCE AND AT
 TR2551'PORT ANGELES.
 TR2551'TO REACH FROM THE INTERSECTION OF LINCOLN STREET AND FRONT STREET IN
 TR2551'PORT ANGELES, GO WEST ON FRONT STREET FOR 0.64 KM (0.40 MI) TO A
 TR2551'FORK. TAKE THE RIGHT FORK AND CONTINUE WESTERLY ON MARINE DRIVE FOR
 TR2551'1.04 KM (0.65 MI) TO A FIRE HYDRANT, POWER LINE POLE NUMBER 125 AND
 TR2551'THE STATION.
 TR2551'THE MARK IS FASTENED TO THE TOP OF A COPPER CLAD STEEL ROAD SET IN A
 TR2551'4-INCH PLASTIC PIPE WITH A CAP. IT IS 2.6 M (8.5 FT) EAST-SOUTHEAST
 TR2551'OF A FIRE HYDRANT AND 2.3 M (7.5 FT) WEST-NORTHWEST OF A POWER LINE
 TR2551'POLE NUMBER 125 THAT HAS A WITNESS SIGN ATTACHED TO IT.
 TR2551'
 TR2551'
 TR2551' STATION RECOVERY (1991)
 TR2551'
 TR2551'RECOVERED 1991
 TR2551'RECOVERED IN GOOD CONDITION.
 TR2551'
 TR2551'
 TR2551' STATION RECOVERY (1994)
 TR2551'
 TR2551'
 TR2551'RECOVERY NOTE BY WOOLPERT CONSULTANTS 1994 (MJS)
 TR2551'RECOVERED AS DESCRIBED.
 TR2551'
 TR2551'
 TR2551' STATION RECOVERY (2000)
 TR2551'
 TR2551'
 TR2551'RECOVERY NOTE BY US POWER SQUADRON 2000
 TR2551'RECOVERED IN GOOD CONDITION.
 TR2551'
 TR2551'
 TR2551' STATION RECOVERY (2012)
 TR2551'
 TR2551'
 TR2551'RECOVERY NOTE BY WA DEPT OF TRANSP 2012 (KW)
 TR2551'RECOVERED AS DESCRIBED.

SECTION 6: GPS CONTROL DIAGRAM

This section contains a graphical representation of the new and existing control stations used for the project.

